



Plus

Design by X. Claramunt and M. de Mas

VIBIA
LIGHT IS CREATION

ASSEMBLY INSTRUCTIONS

WARNING: Use only flare seal CF lamps (Safety fuse built-in). Contact your lamp manufacturer for additional information. Failure to do so can result in fire or damage.

All wiring must be in accordance with national and local electrical codes. If you are not familiar with wiring, you should use a qualified electrician.

SUPPLIED MATERIAL

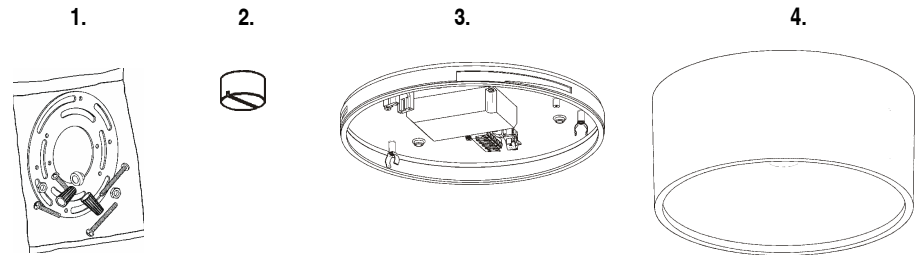

	0630
1 Instalation components bag	1 un.
2 Caps	3 un.
3 Plaque	1 un.
4 Lamp structure	1 un.

TECHNICAL SPECIFICATIONS

0630. Net Weight 6,8 Kg



1 x T-5 Circline 2GX13 40W



IP65



us



Class I. Product with an additional protection cable (grounds).



Dust-tight product. Protected against water trickles.



Product that CAN be in contact with normally-flammable materials (wood or others).

Caution

Before assembling and installing this product, carefully read the following:

- Switch of the mains before installing the lamp.
- Always use the recommended bulb
- To install on the ceiling, always choose the most adequate fixing tools for the ceiling material.
- We recommend reading the manual before installaing the lamp. Keep this instructions for future reference.

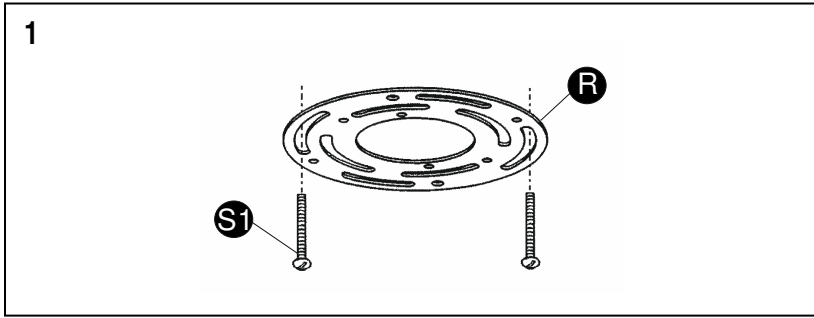

IMPORTANT NOTICE:

Switch off the mains before installing the lamp.

1. Making certain that the threads of the cross bar screws are pointing away from the wall, secure the round cross bar (R) to the junction box using the mounting screws (S1).

2 Connect the white fixture wire to the white wire of the supply circuit. Connect the black fixture wire to the black wire of the supply circuit. Secure with the wire nuts (N) and tape connections with electrical tape. Connect the fixture yellow and green ground wire and the supply green tinted ground wire to the ground screw on the round cross bar using the ground terminal. Push the connections and all excess wire to the interior of the junction box. Spread the electrical splices on the round cross bar (R) so that the black wires are on one side of the junction box and the white wires on the other. Secure the plate (A) to the round cross bar, using the screws (S2).

3. Threading the three caps (B) provided in its position. Be sure to push them to ensure a proper seal.

4. Fit body (C) to base plate (A) by turning it in the direction shown by the arrows, so that the three tabs inside the body fit snugly over the respective hooks on the base plate.

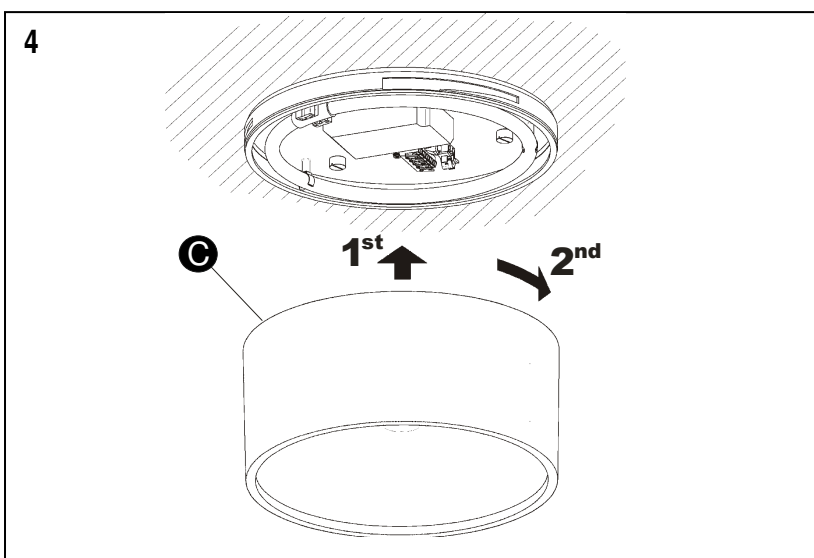
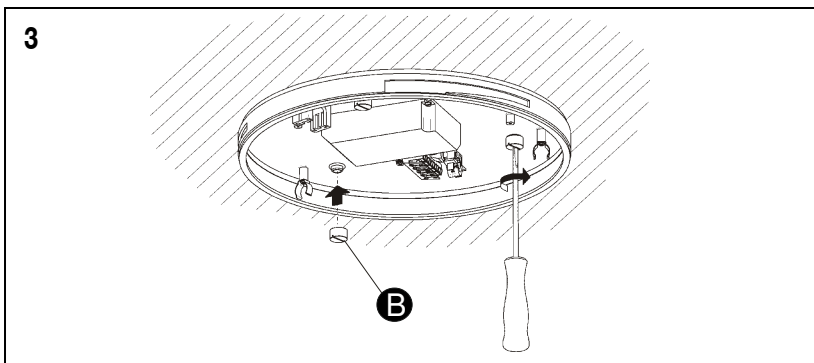
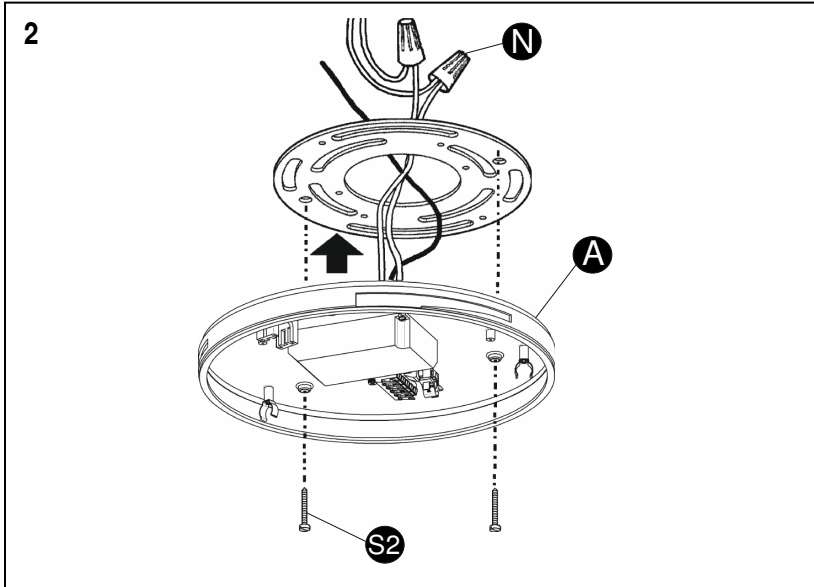

Maintenance

- Use a slightly-wet cotton cloth for cleaning.
- In case of malfunction or damage, please contact the retailer who sold the lamp.