

# ASTOLFO

Design Amedeo G. Cavalchini

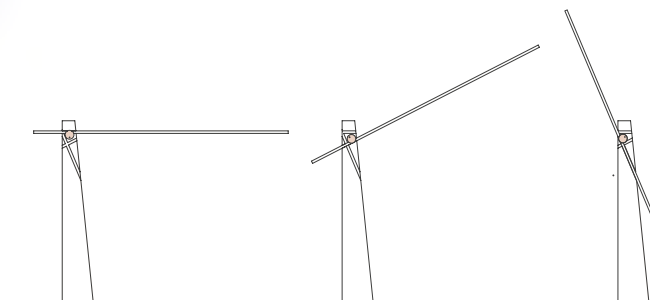

## CAVALIERE LUMINOSO

L'epica cavalleresca offre lo spunto progettuale per la lampada da terra ASTOLFO, connubio tra la struttura ancestrale e rassicurante del legno e la tecnologia estrema della sorgente LED e del profilo minimale. Il suo design emula l'ordinato grafismo di una lancia luminosa, sottile e tecnologica, inserita meccanicamente in un fusto di legno massiccio attraversato da tagli netti e precisi, in cui la lancia può essere inserita secondo tre diversi angoli e orientamenti.

## BRIGHT KNIGHT

*The chivalrous epic inspires the floor lamp ASTOLFO, melting the ancestral and soothing structure of wood, the extreme technology of LED source and its minimal outline. Its design emulates the linear graphism of a light spear, thin and technological, mechanically inserted in a solid wood stem crossed by sharp and precise carves, where the light-spear can be placed in three different angles and orientations.*

## 輝く騎士 (ナイト)

騎士の抒情詩が、このフロアーランプ「アストルフォ」のデザインの出発点となりました。不変とも言える天然木から作られた構造体を与える安心感に、ミニマルなラインで作られた最新技術のLED光源を融合させました。見た目にも特徴的なこの精悍な細く光る「テクノロジーの槍」とも言える発光部が、木製の台座に刻まれた溝の中に納まります。この溝によって3つの違う角度に向きが変えられます。

# ASTOLFO

Design Amedeo G. Cavalchini

Lampada da terra con doppia sorgente luminosa LED. Costituita da una base in legno massello di rovere o noce nazionale e un'asta in alluminio anodizzato di colore nero. Le tre scanalature presenti nella parte superiore della base consentono all'asta di essere posizionata con tre differenti angoli rispetto alla base stessa, consentendo un approccio tattile e personale con la lampada.

Le sorgenti LED dimmerabili sono collocate lungo l'asta e nel retro della base consentendo un'illuminazione sia diretta che indiretta.

*Floor lamp with double LED light sources. Solid oak or walnut base and arm in black anodized aluminium. Three carves on the top of the trunk allow to place the arm in three different angles giving the lamp a personal touch. The dimmable LED sources are along the arm and on the base back, creating both indirect and direct lighting.*

二重のLED光源を持つフロアーランプ。ウォールナットまたはオークの無垢木材のベースにアルミ製ブラック・アルマイト仕上げのアーム。台座の上部に刻まれた溝は、アーム部分を三つの異なる角度に固定することができます。これによってこのランプは、見た目と空間と共に自由なアプローチを生み出す事が可能です。アーム部分とベースの背面に内蔵されたLED光源は、調光が可能で、直接照明と間接照明の二種類のあかりを同時に演出します。

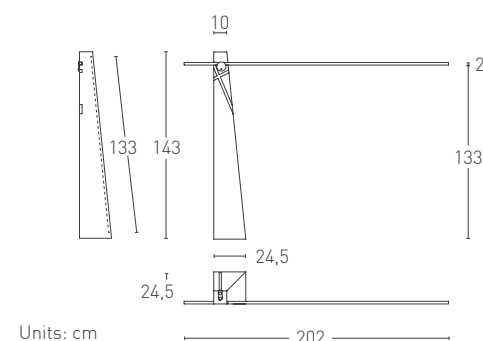

## Finishes

- LN Walnut
- LR Oak

## Diffuser

- 174 Black anodized aluminium

## Cable

Black fabric

## Electronic driver

Dimmable included

## Light source

LED

Arm **LED** 36W 220/240V  
3240lm 3000K CRI>90  
Base **LED** 24W 220/240V  
2160lm 3000K CRI>90

A

## Certification





# ASTOLFO HT

Design Amedeo G. Cavalchini

Lampada da terra con base realizzata in scatolato di acciaio verniciato e fronte in massello di rovere o noce. Le tre scanalature presenti nella parte superiore della base consentono all'asta luminosa - realizzata in alluminio anodizzato nero - di essere posizionata con tre differenti angoli rispetto alla base stessa, consentendo un approccio tattile e personale con la lampada.

La sorgente LED dimmerabile collocata nell'asta fornisce luce diretta o indiretta a seconda del posizionamento.

*Floor lamp with folded sheet steel base and front cover in solid oak or walnut. Three carves on the top of the trunk allow to place the arm - with black anodized aluminum finish - in three different angles giving the lamp a personal touch.*

*The dimmable LED source placed along the arm gives direct or indirect light according to the different positioning.*

スチール製ケースの台座にウォールナットまたはオークの無垢木材のファサード（表面）を使用したフロアランプ。台座の上部に刻まれた溝は、アーム部分を三つの異なる角度に固定することができます。これによってこのランプは、見た目と空間と共に自由なアプローチを生み出す事が可能です。

アーム部分は直接照明と間接照明の二種類のあかりを好みの配置によって選ぶことができます。

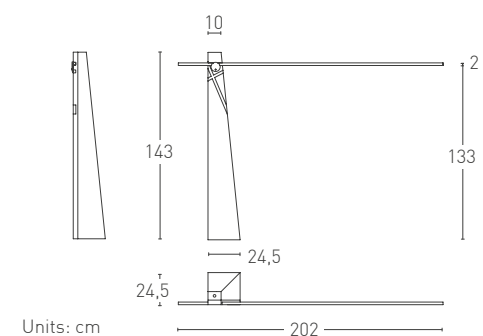

## Finishes

- 115D FT Graphite grey + LR Oak
- 115D FT Graphite grey + LN Walnut

## Diffuser

- 174 Black anodized aluminium

## Cable

Black fabric

## Electronic driver

Dimmable included

## Light source

LED

LED 36W 220/240V  
3240lm 3000K CRI>90



## Certification

