

# ARABIAN PEARLS

ARABIAN PEARLS IS A REGISTERED DESIGN BY COEN MUNSTERS 2014

## ARABIAN PEARLS H6+1

**10110** / WITHOUT CRYSTAL  
**10111** / SWAROVSKI STRASS  
 BASE: 6 X E14 / 220V / MAX. 40W  
 BASE DOWNLIGHT: 1 X GU10 / 220V / MAX. 50W  
 COLORS: 00-02-05  
 SHADE: WHITE / WHITE CRUSHED / BLACK / BLACK CRUSHED  
 RED / RED CRUSHED / BROWN / BROWN CRUSHED

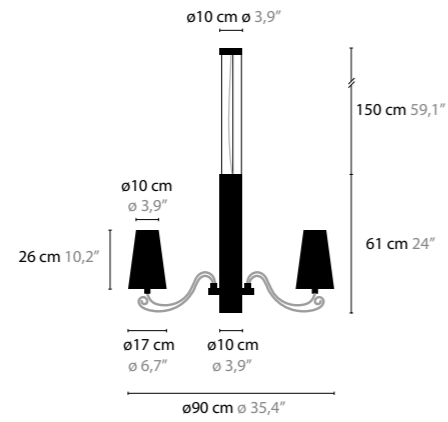

## ARABIAN PEARLS H8+1

**10120** / WITHOUT CRYSTAL  
**10121** / SWAROVSKI STRASS  
 BASE: 8 X E14 / 220V / MAX. 40W  
 BASE DOWNLIGHT: 1 X GU10 / 220V / MAX. 50W  
 COLORS: 00-02-05  
 SHADE: WHITE / WHITE CRUSHED / BLACK / BLACK CRUSHED  
 RED / RED CRUSHED / BROWN / BROWN CRUSHED

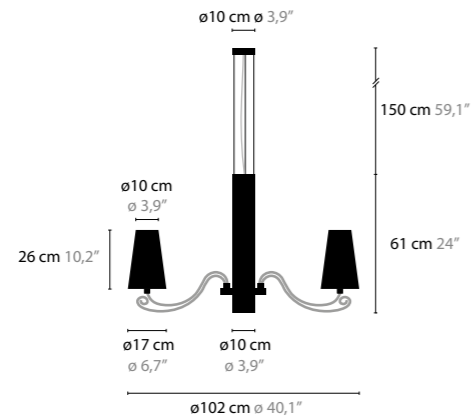

## ARABIAN PEARLS H12+1

**10130** / WITHOUT CRYSTAL  
**10131** / SWAROVSKI STRASS  
 BASE: 12 X E14 / 220V / MAX. 40W  
 BASE DOWNLIGHT: 1 X GU10 / 220V / MAX. 50W  
 COLORS: 00-02-05  
 SHADE: WHITE / WHITE CRUSHED / BLACK / BLACK CRUSHED  
 RED / RED CRUSHED / BROWN / BROWN CRUSHED

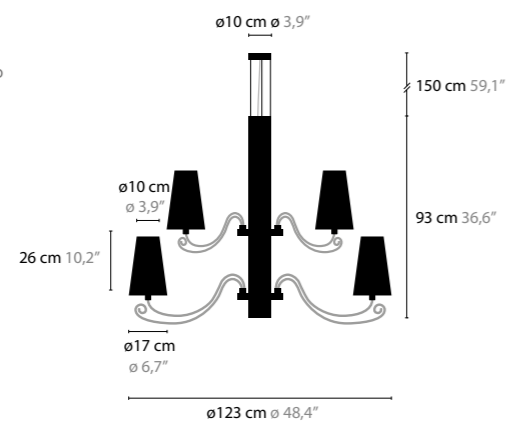

## ARABIAN PEARLS W1

**10150** / WITHOUT CRYSTAL  
**10151** / SWAROVSKI STRASS  
 BASE: 1 X E14 / 220V / MAX. 25W  
 COLORS: 00-02-05  
 SHADE: WHITE / WHITE CRUSHED / BLACK / BLACK CRUSHED  
 RED / RED CRUSHED / BROWN / BROWN CRUSHED

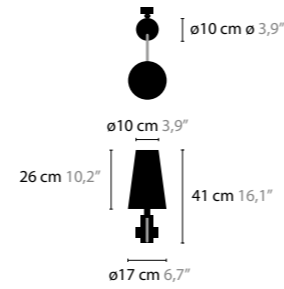

## ARABIAN PEARLS W2

**10160** / WITHOUT CRYSTAL  
**10161** / SWAROVSKI STRASS  
 BASE: 2 X E14 / 220V / MAX. 25W  
 COLORS: 00-02-05  
 SHADE: WHITE / WHITE CRUSHED / BLACK / BLACK CRUSHED  
 RED / RED CRUSHED / BROWN / BROWN CRUSHED

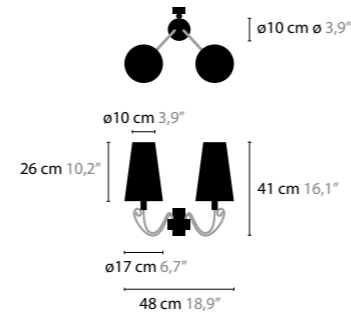

## ARABIAN PEARLS W3

**10170** / WITHOUT CRYSTAL  
**10171** / SWAROVSKI STRASS  
 BASE: 3 X E14 / 220V / MAX. 25W  
 COLORS: 00-02-05  
 SHADE: WHITE / WHITE CRUSHED / BLACK / BLACK CRUSHED  
 RED / RED CRUSHED / BROWN / BROWN CRUSHED

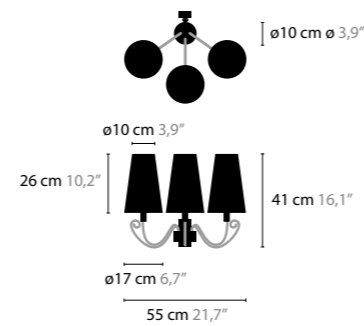

THE ARABIAN HISTORICAL ARCHITECTURE WITH ITS MASSIVE CONSTRUCTIONS COMBINED WITH THE MOST ELEGANT AND FABULOUS FINE DETAILS WAS THE INSPIRATION FOR THE DESIGN OF 'ARABIAN PEARLS', WHERE, AS WELL, A MASSIVE CONSTRUCTION IS COMBINED WITH THE MOST ELEGANT LINES AND DETAILS, RESULTING IN FASCINATING LIGHT SCULPTURES.