

PHOENIX

Design ANDREA LAZZARI

PHOENIX SP

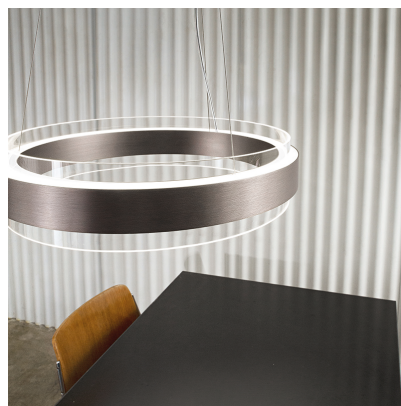

Elegant game of geometries and circular joints with a strong decorative connotation, which embellishes and illuminates the room with a strong but discreet personality. The LED light source is very efficient and completely hidden in the structure. Direct lighting defines the area of light below, enhancing the natural beauty of the smoky, amber and crystal tones embellished with black nickel and copper finishes.



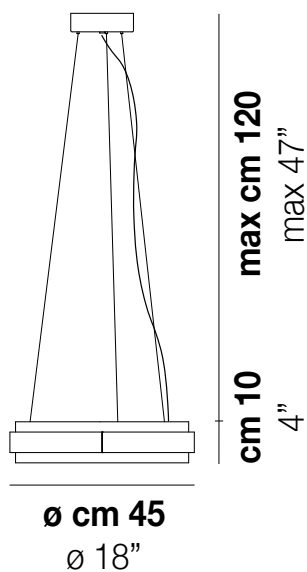

PHOENIX SP

TECHNICAL DATA:



CERTIFICATIONS:



1x34w 220-240V
50/60 Hz LED

VOLUME Mc 0
GROSS WEIGHT Kg 0
NET WEIGHT Kg 0

download



SHADE FINISHING



AMTR

CRTR

FUTR

FRAME FINISHING

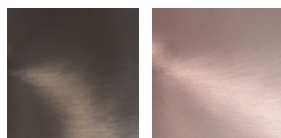

NNS

RAV