

# TECHNICKÝ LIST

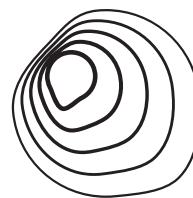

BROKIS

<b>Název</b>	Závěsné svítidlo
<b>Typ</b>	Shadows XL
<b>ID</b>	PC940
<b>Popis</b>	Díky propojení ručně foukaného skla, řemeslně zpracovaného dřeva a klasickému tvarosloví vzniká svítidlo nestárnoucí elegance. Kolekce nabízí 4 varianty závěsných svítidel, která plní svou funkci buď samostatně, nebo v setech po více kusech.

**Technický popis** Svítidlo je složeno z dřevěné části s přípojovacím konektorem a objímkou E27, z přívodního kabelu s konektorem a skleněné části.  
Svítidlo se zavěšuje na stropní baldachýn.

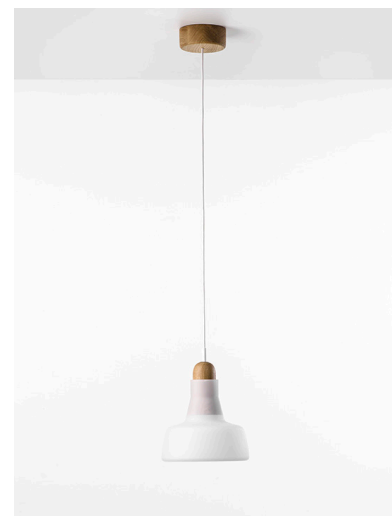

## KONSTRUKČNÍ SPECIFIKACE

<b>Hmotnost [kg]</b>	2 kg
<b>Použité materiály</b>	sklo, dřevo, kov
<b>délka přípojovacího vodiče [mm]</b>	2,000 mm
<b>Montáž</b>	Strop
<b>Prostředí</b>	Vnitřní

## ELEKTRICKÁ SPECIFIKACE

<b>Jmenovité napětí [V]</b>	230 VDC
<b>Frekvence [Hz]</b>	50-60 Hz
<b>Max. příkon [W]</b>	15W LED
<b>Krytí IP</b>	20
<b>Patice</b>	E27
<b>Světelný zdroj</b>	-
<b>Energetická třída</b>	A+ až B dle použitého zdroje

## Rozměr [mm]

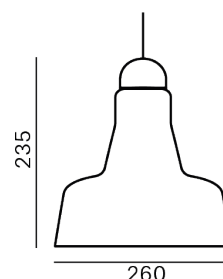

## Certifikace



# TECHNICKÝ LIST

## DOPORUČENÉ SVĚTELNÉ ZDROJE

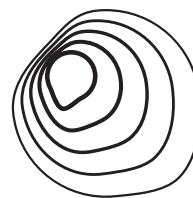

BROKIS



### LAMPJA E27-SILVER-60°

<b>Patice</b>	E27
<b>Typ</b>	LED
<b>Příkon [W]</b>	13 W
<b>Vstupní napětí [V]</b>	220 - 240 VAC
<b>Energetická třída</b>	A+
<b>Světelný tok [lm]</b>	700 lm
<b>Barevná teplota [K]</b>	2700 K
<b>CRI</b>	90+
<b>Životnost [h]</b>	25000h
<b>Stmívatelnost</b>	ano
<b>Rozměry v x š [mm]</b>	95 x 63 mm

### STROPNÍ BALDACHÝN

<b>Rozměry <math>\varnothing</math> x v [mm]</b>	60 x 50 mm
<b>Hmotnost [kg]</b>	0.055 kg
<b>Materiál</b>	dřevo

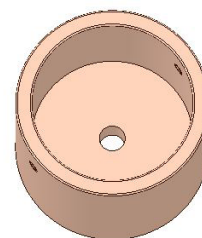

#### Nákres

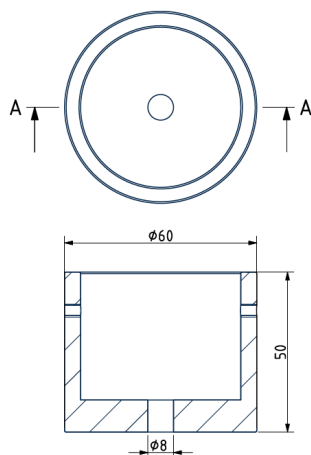

#### Držák baldachýnu

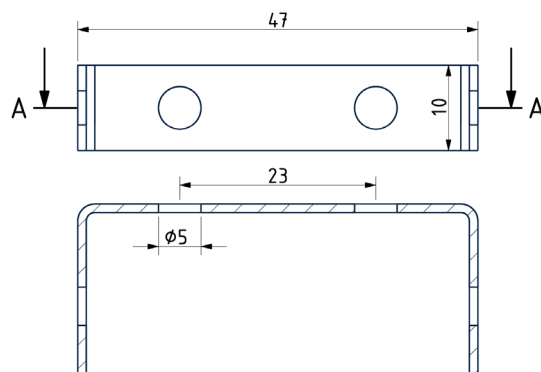

# DATASHEET

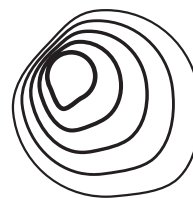

BROKIS

<b>Name</b>	Suspension light
<b>Type</b>	Shadows XL
<b>ID</b>	PC940
<b>Description</b>	The combination of handblown glass, handcrafted wood, and classic shaping has given rise to a light of ageless elegance. The collection comprises four different suspension lights, as striking alone as they are in sets, characterized by a hand-blown glass shade set upon on a handcrafted wooden body.
<b>Tech. description</b>	The light consists of a wooden body with connector and E27 light source socket. It also includes a lead cable with connector, the glass shade, and a wood ceiling canopy.

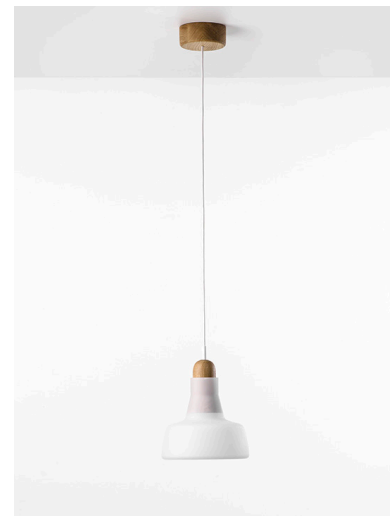

## CONSTRUCTION SPECIFICATION

<b>Weight [kg]</b>	2 kg
<b>Construction material</b>	glass, wood, metal
<b>Cord length [mm]</b>	2,000 mm
<b>Mounting</b>	Ceiling
<b>Environment</b>	Indoor

## Dimensions [mm]

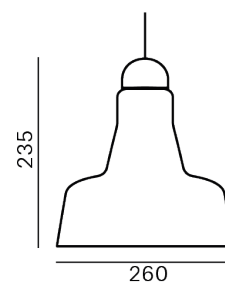

## ELECTRICAL SPECIFICATION

<b>Input voltage [V]</b>	230 VDC
<b>Frequency [Hz]</b>	50-60 Hz
<b>Max. power [W]</b>	15 W
<b>Coverage IP</b>	20
<b>Socket</b>	E27
<b>Light source</b>	-
<b>Energy class</b>	A+ to B depending on light source

## Certifications



# DATASHEET

## RECOMMENDED BULBS



### LAMPIA E27-SILVER-60°

Socket	E27
Type	LED
Lamp wattage [W]	13 W
Input voltage [V]	220 - 240 VAC
Energy class	A+
Flux[lm]	700 lm
Light Colour [K]	2,700 K
CRI	90+
Lifespan [h]	25,000h
Dimmable	yes
Dimensions h x w [mm]	95 x 63 mm

### Ceiling Canopy

Dimensions $\varnothing$ x w [mm]	60 x 50 mm
Weight [kg]	0.055 kg
Material	wood

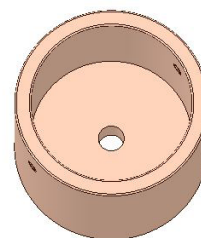

### Drawing

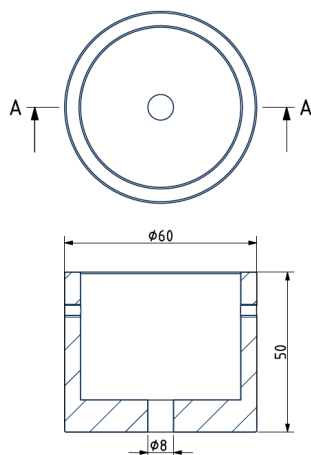

### Canopy bracket

