

GLOUGLOU

code: **2044/130/DIM/L/1/AR**

DESIGN EMILIANA MARTINELLI 2007



HANGING LAMP FOR DIFFUSED LIGHT, FORMED BY A SATIN WHITE OPAL METHACRYLATE DIFFUSER AND A CENTRAL RING OF TRANSPARENT OR ORANGE COLOR METHACRYLATE. LED LIGHT SOURCE INTEGRATED. ELECTRONIC DRIVERS DIMMABLE INCLUDED.

TECHNICAL DRAWINGS

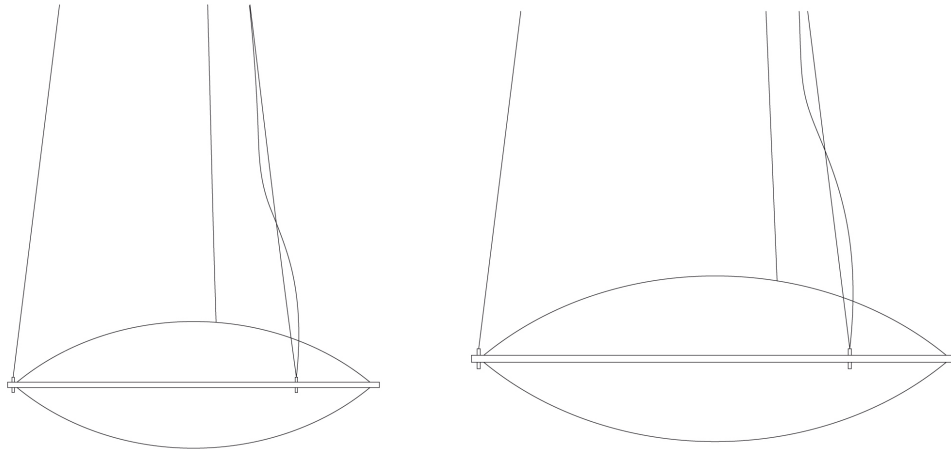

UTILIZATION: INTERNAL		TPOLOGY: HANGING		
COLOURS	STRUCTURE: DIFFUSER:	WHITE ORANGE		
MATERIALS	STRUCTURE: DIFFUSER:	METHACRYLATE		
MEASURES	WIDTH: - HEIGHT: - LENGTH: - DEPTH: -	DIAMETER: 130 cm HOLE DIAMETER: - HOLE DEPTH: -	WEIGHT NET: 15 GROSS: 18	
	PACKAGING VOL.M ³ : 140X140X40		NUMBER OF ITEMS: 1	
BULBS	LED 1X230W FLUX: 13980LM KELVIN: 3000° CLASS: A++ CRI: >80 COLOR TOLERANCE: - DURATION: 40000H			
DEVICE SPECIFICATIONS				
TYPE OF EMISSION: DIFFUSED		POWER SUPPLY CABLE LENGTH: 600cm		
POWER: -		LENGTH OF HANGING CABLE: 500cm		
FLOW LAMP: -		SUPPLY: INCLUDED		
BEAM ANGLE: -		POWER SUPPLY ASSEMBLY: -		
DEVICE EFFICIENCY: -lm/W		TYPE OF DIMMING: PUSH/DALI		
IMPACT RESISTENCE: -		VOLTAGE: 230 V		
GLOW WIRE TEST: -		POWER SUPPLY: ELECTRONIC DIMMABLE POWER SUPPLY		
CERTIFICATIONS				
MARKETS	THIS ITEM IS AVAILABLE IN THE FOLLOWING COUNTRIES: EUROPE			

GLOUGLOU

code: *2044/130/DIM/L/1/AR*

DESIGN **EMILIANA MARTINELLI** 2007

TECHNICAL DRAWINGS



PHOTO GALLERY



GLOUGLOU

code: **2044/130/DIM/L/1/TR**

DESIGN EMILIANA MARTINELLI 2007



HANGING LAMP FOR DIFFUSED LIGHT, FORMED BY A SATIN WHITE OPAL METHACRYLATE DIFFUSER AND A CENTRAL RING OF TRANSPARENT OR ORANGE COLOR METHACRYLATE. LED LIGHT SOURCE INTEGRATED. ELECTRONIC DRIVERS DIMMABLE INCLUDED.

TECHNICAL DRAWINGS

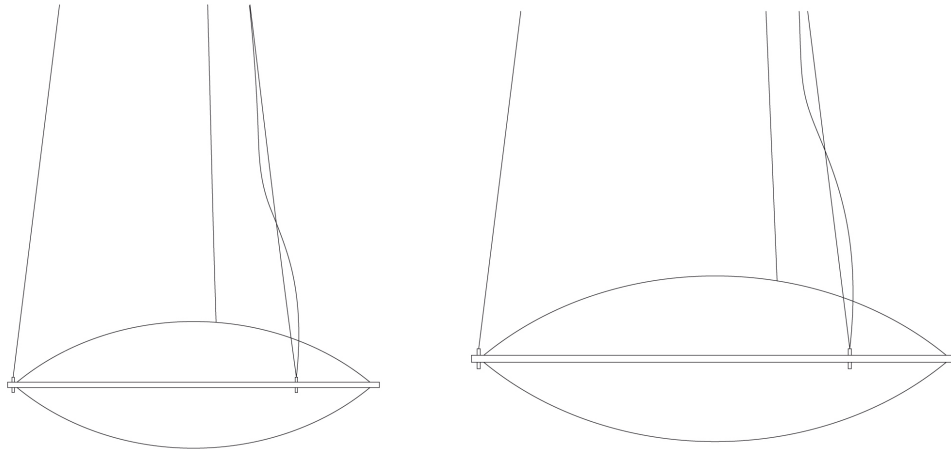

UTILIZATION:	INTERNAL	TPOLOGY:	HANGING	
COLOURS	STRUCTURE: DIFFUSER:	WHITE TRANSPARENT		
MATERIALS	STRUCTURE: DIFFUSER:	METHACRYLATE		
MEASURES	WIDTH: - HEIGHT: - LENGTH: - DEPTH: -	DIAMETER: 130 cm HOLE DIAMETER: - HOLE DEPTH: -	WEIGHT NET: 15 GROSS: 18	
	PACKAGING VOL.M ³ : 140X140X40		NUMBER OF ITEMS: 1	
BULBS	LED 1X230W FLUX: 13980LM KELVIN: 3000° CLASS: A++ CRI: >80 COLOR TOLERANCE: - DURATION: 40000H			
DEVICE SPECIFICATIONS	TYPE OF EMISSION: DIFFUSED POWER: - FLOW LAMP: - BEAM ANGLE: - DEVICE EFFICIENCY: -lm/W IMPACT RESISTENCE: - GLOW WIRE TEST: -		POWER SUPPLY CABLE LENGTH: 600cm LENGTH OF HANGING CABLE: 500cm SUPPLY: INCLUDED POWER SUPPLY ASSEMBLY: - TYPE OF DIMMING: PUSH/DALI VOLTAGE: 230 V	
	POWER SUPPLY: ELECTRONIC DIMMABLE POWER SUPPLY			
CERTIFICATIONS				
MARKETS	THIS ITEM IS AVAILABLE IN THE FOLLOWING COUNTRIES: EUROPE			

GLOUGLOU

code: *2044/130/DIM/L/1/TR*

DESIGN **EMILIANA MARTINELLI** 2007

TECHNICAL DRAWINGS



PHOTO GALLERY



GLOUGLOU

code: **2044/170/DIM/L/1/AR**

DESIGN **EMILIANA MARTINELLI** 2007



HANGING LAMP FOR DIFFUSED LIGHT, FORMED BY A SATIN WHITE OPAL METHACRYLATE DIFFUSER AND A CENTRAL RING OF TRANSPARENT OR ORANGE COLOR METHACRYLATE. LED LIGHT SOURCE INTEGRATED. ELECTRONIC DRIVERS DIMMABLE INCLUDED.

TECHNICAL DRAWINGS

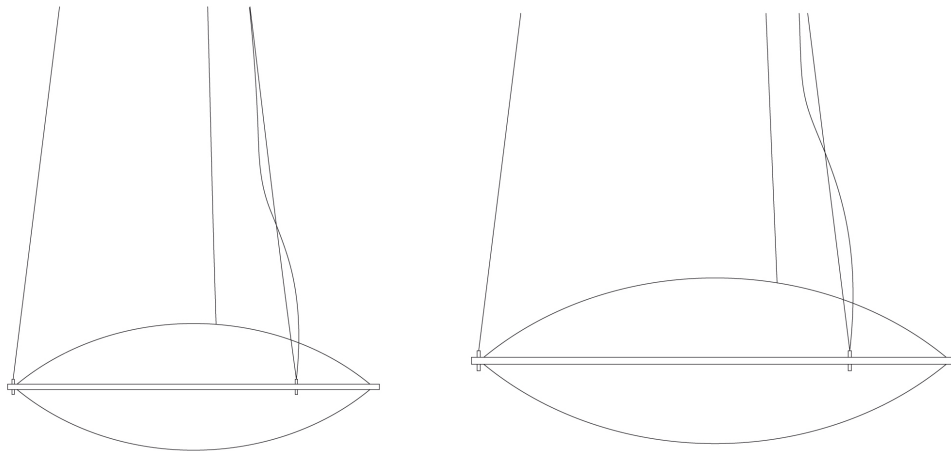

UTILIZATION:	INTERNAL	TPOLOGY:	HANGING	
COLOURS	STRUCTURE: DIFFUSER:	WHITE ORANGE		
MATERIALS	STRUCTURE: DIFFUSER:	METHACRYLATE		
MEASURES	WIDTH: - HEIGHT: - LENGTH: - DEPTH: -	DIAMETER: 170 cm HOLE DIAMETER: - HOLE DEPTH: -	WEIGHT NET: 25 GROSS: 29	
	PACKAGING VOL.M ³ : 180X180X50		NUMBER OF ITEMS: 1	
BULBS	LED 1X285W FLUX: 36720LM KELVIN: 3000° CLASS: A++ CRI: >80 COLOR TOLERANCE: - DURATION: 50000H			
				
DEVICE SPECIFICATIONS	TYPE OF EMISSION: DIFFUSED		POWER SUPPLY CABLE LENGTH: 600cm	
	POWER: -	LENGTH OF HANGING CABLE: 500cm		
	FLOW LAMP: -	SUPPLY: INCLUDED		
	BEAM ANGLE: -	POWER SUPPLY ASSEMBLY: -		
	DEVICE EFFICIENCY: -lm/W	TYPE OF DIMMING: PUSH/DALI		
	IMPACT RESISTENCE: -	VOLTAGE: 230 V		
	GLOW WIRE TEST: -			
	POWER SUPPLY: ELECTRONIC DIMMABLE POWER SUPPLY			
CERTIFICATIONS				
MARKETS	THIS ITEM IS AVAILABLE IN THE FOLLOWING COUNTRIES: EUROPE			

GLOUGLOU

code: *2044/170/DIM/L/1/AR*

DESIGN **EMILIANA MARTINELLI** 2007

TECHNICAL DRAWINGS



PHOTO GALLERY



GLOUGLOU

code: **2044/170/DIM/L/1/TR**



DESIGN EMILIANA MARTINELLI 2007

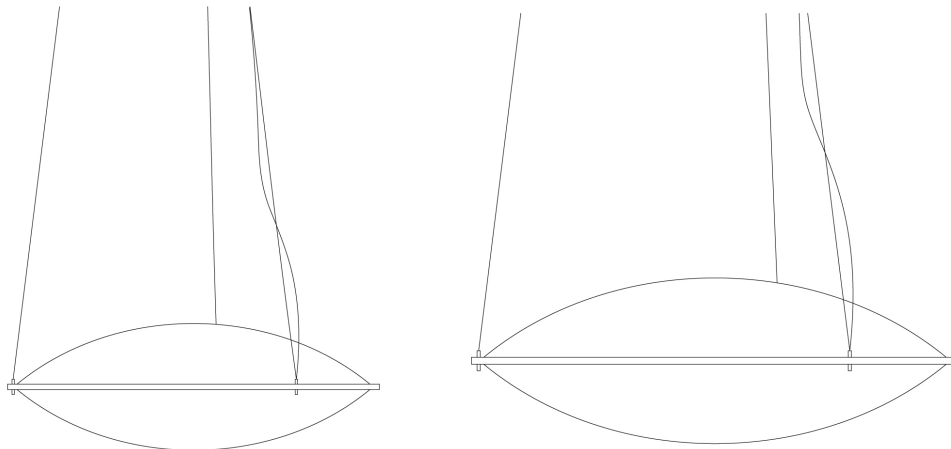

HANGING LAMP FOR DIFFUSED LIGHT, FORMED BY A SATIN WHITE OPAL METHACRYLATE DIFFUSER AND A CENTRAL RING OF TRANSPARENT OR ORANGE COLOR METHACRYLATE. LED LIGHT SOURCE INTEGRATED. ELECTRONIC DRIVERS DIMMABLE INCLUDED.

TECHNICAL DRAWINGS



UTILIZATION:	INTERNAL	TPOLOGY:	HANGING	
COLOURS	STRUCTURE: DIFFUSER:	WHITE TRANSPARENT		
MATERIALS	STRUCTURE: DIFFUSER:	METHACRYLATE		
MEASURES	WIDTH: - HEIGHT: - LENGTH: - DEPTH: -	DIAMETER: 170 cm HOLE DIAMETER: - HOLE DEPTH: -	WEIGHT NET: 25 GROSS: 29	
	PACKAGING VOL.M ³ : 180X180X50		NUMBER OF ITEMS: 1	
BULBS	LED 1X285W FLUX: 36720LM KELVIN: 3000° CLASS: A++ CRI: >80 COLOR TOLERANCE: - DURATION: 50000H			
				
DEVICE SPECIFICATIONS	TYPE OF EMISSION: DIFFUSED		POWER SUPPLY CABLE LENGTH: 600cm	
	POWER: -	LENGTH OF HANGING CABLE: 500cm		
	FLOW LAMP: -	SUPPLY: INCLUDED		
	BEAM ANGLE: -	POWER SUPPLY ASSEMBLY: -		
	DEVICE EFFICIENCY: -lm/W	TYPE OF DIMMING: PUSH/DALI		
	IMPACT RESISTENCE: -	VOLTAGE: 230 V		
	GLOW WIRE TEST: -			
	POWER SUPPLY: ELECTRONIC DIMMABLE POWER SUPPLY			
CERTIFICATIONS				
MARKETS	THIS ITEM IS AVAILABLE IN THE FOLLOWING COUNTRIES: EUROPE			

GLOUGLOU

code: *2044/170/DIM/L/1/TR*

DESIGN **EMILIANA MARTINELLI** 2007

TECHNICAL DRAWINGS



PHOTO GALLERY



GLOUGLOU

code: **2044/55/DIM/L/1/AR**

DESIGN EMILIANA MARTINELLI 20016



HANGING LAMP FOR DIFFUSED LIGHT, FORMED BY A SATIN WHITE OPAL METHACRYLATE DIFFUSER AND A CENTRAL RING OF TRANSPARENT OR ORANGE COLOR METHACRYLATE. LED LIGHT SOURCE INTEGRATED. ELECTRONIC DRIVERS DIMMABLE INCLUDED.

TECHNICAL DRAWINGS

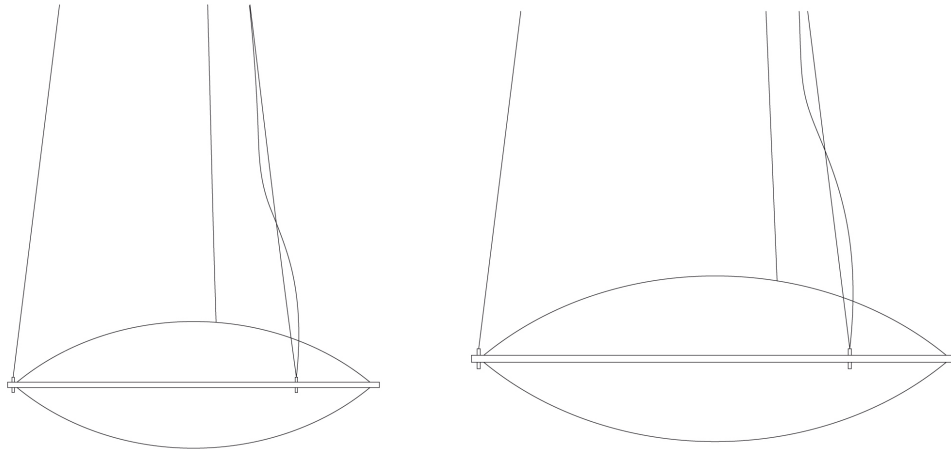

UTILIZATION:	INTERNAL	TPOLOGY:	HANGING	
COLOURS	STRUCTURE: DIFFUSER:	WHITE ORANGE		
MATERIALS	STRUCTURE: DIFFUSER:	METHACRYLATE		
MEASURES	WIDTH: - HEIGHT: 22 cm LENGTH: - DEPTH: -	DIAMETER: 55 cm HOLE DIAMETER: - HOLE DEPTH: -	WEIGHT NET: 5,5 GROSS: 7	
	PACKAGING VOL.M ³ : 60X55X32		NUMBER OF ITEMS: 1	
BULBS	LED 2X32W FLUX: 3360LM KELVIN: 3000° CLASS: A++ CRI: >80 COLOR TOLERANCE: - DURATION: 40000H			
				
DEVICE SPECIFICATIONS	TYPE OF EMISSION: DIFFUSED POWER: 69 W FLOW LAMP: 7450 lm BEAM ANGLE: - DEVICE EFFICIENCY: 108lm/W IMPACT RESISTENCE: - GLOW WIRE TEST: -		POWER SUPPLY CABLE LENGTH: 400cm LENGTH OF HANGING CABLE: 350cm SUPPLY: INCLUDED POWER SUPPLY ASSEMBLY: - TYPE OF DIMMING: PUSH/DALI VOLTAGE: 230 V	
	POWER SUPPLY: ELECTRONIC DIMMABLE POWER SUPPLY			
CERTIFICATIONS	   			
MARKETS	THIS ITEM IS AVAILABLE IN THE FOLLOWING COUNTRIES: EUROPE			

GLOUGLOU

code: *2044/55/DIM/L/1/AR*

DESIGN **EMILIANA MARTINELLI** 20016

TECHNICAL DRAWINGS

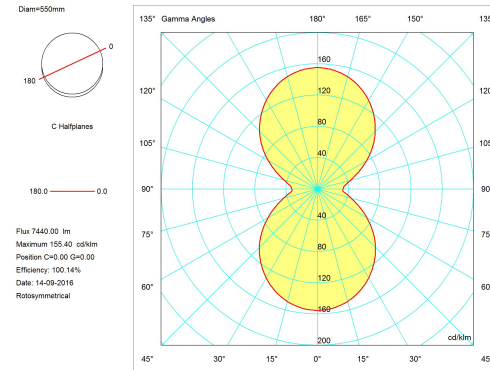

PHOTO GALLERY



GLOUGLOU

code: **2044/55/DIM/L/1/TR**

DESIGN EMILIANA MARTINELLI 2007



HANGING LAMP FOR DIFFUSED LIGHT, FORMED BY A SATIN WHITE OPAL METHACRYLATE DIFFUSER AND A CENTRAL RING OF TRANSPARENT OR ORANGE COLOR METHACRYLATE. LED LIGHT SOURCE INTEGRATED. ELECTRONIC DRIVERS DIMMABLE INCLUDED.

TECHNICAL DRAWINGS

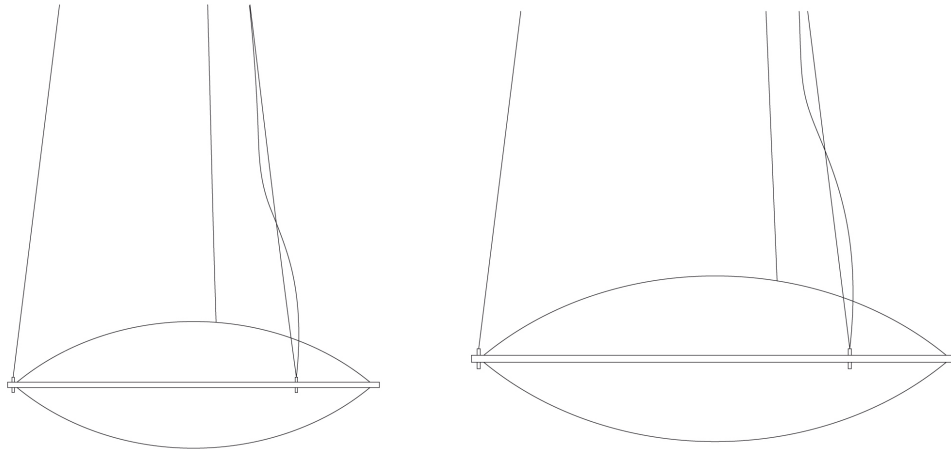

UTILIZATION:	INTERNAL	TPOLOGY:	HANGING	
COLOURS	STRUCTURE: DIFFUSER:	WHITE TRANSPARENT		
MATERIALS	STRUCTURE: DIFFUSER:	METHACRYLATE		
MEASURES	WIDTH: - HEIGHT: - LENGTH: - DEPTH: -	DIAMETER: 55 cm HOLE DIAMETER: - HOLE DEPTH: -	WEIGHT NET: 5,5 GROSS: 7	
	PACKAGING VOL.M ³ : 60X55X32		NUMBER OF ITEMS: 1	
BULBS	LED 2X32W FLUX: 3360LM KELVIN: 3000° CLASS: A++ CRI: >80 COLOR TOLERANCE: - DURATION: 40000H			
				
DEVICE SPECIFICATIONS	TYPE OF EMISSION: DIFFUSED POWER: 69 W FLOW LAMP: 7450 lm BEAM ANGLE: - DEVICE EFFICIENCY: 108lm/W IMPACT RESISTENCE: - GLOW WIRE TEST: -		POWER SUPPLY CABLE LENGTH: 400cm LENGTH OF HANGING CABLE: 350cm SUPPLY: INCLUDED POWER SUPPLY ASSEMBLY: - TYPE OF DIMMING: PUSH/DALI VOLTAGE: 230 V	
	POWER SUPPLY: ELECTRONIC DIMMABLE POWER SUPPLY			
CERTIFICATIONS	   			
MARKETS	THIS ITEM IS AVAILABLE IN THE FOLLOWING COUNTRIES: EUROPE			

GLOUGLOU

code: *2044/55/DIM/L/1/TR*

DESIGN **EMILIANA MARTINELLI** 2007

TECHNICAL DRAWINGS

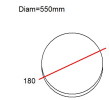
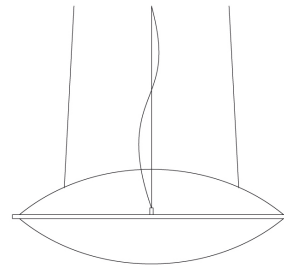
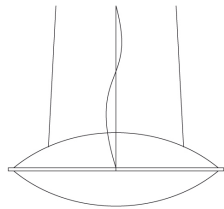

C Halfplanes

180.0 — 0.0

Flux 7440.00 lm
Maximum 155.40 cp/klm
Position C=0.00 G=0.00
Efficiency 100.14%
Date: 14-09-2016
Rotosymmetrical

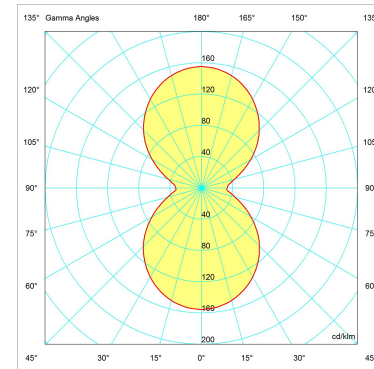

PHOTO GALLERY



GLOUGLOU

code: **2044/85/DIM/L/1/AR**

DESIGN **EMILIANA MARTINELLI** 2007



HANGING LAMP FOR DIFFUSED LIGHT, FORMED BY A SATIN WHITE OPAL METHACRYLATE DIFFUSER AND A CENTRAL RING OF TRANSPARENT OR ORANGE COLOR METHACRYLATE. LED LIGHT SOURCE INTEGRATED. ELECTRONIC DRIVERS DIMMABLE INCLUDED.

TECHNICAL DRAWINGS

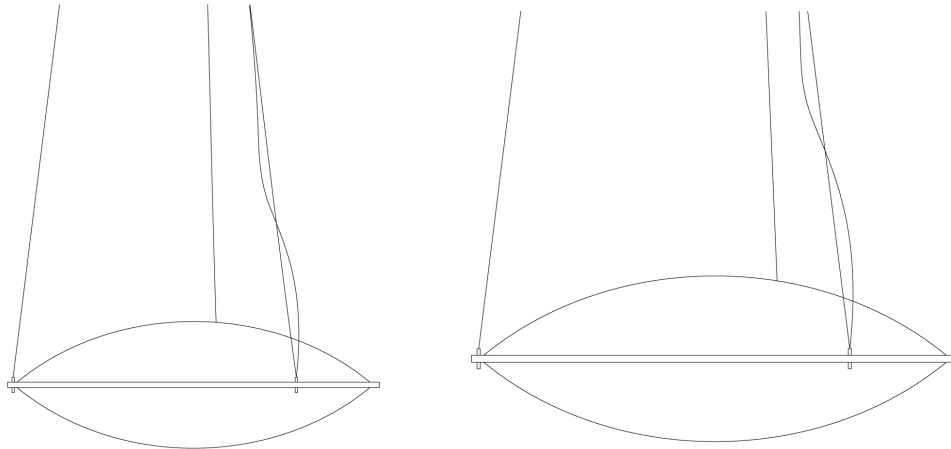

UTILIZATION:	INTERNAL	TPOLOGY:	HANGING	
COLOURS	STRUCTURE: DIFFUSER:	WHITE ORANGE		
MATERIALS	STRUCTURE: DIFFUSER:	METHACRYLATE		
MEASURES	WIDTH: - HEIGHT: - LENGTH: - DEPTH: -	DIAMETER: 85 cm HOLE DIAMETER: - HOLE DEPTH: -	WEIGHT NET: 6,5 GROSS: 8,5	
	PACKAGING VOL.M ³ : 100X100X40		NUMBER OF ITEMS: 1	
BULBS	LED 1X120W FLUX: 7500LM KELVIN: 3000° CLASS: A++ CRI: >80 COLOR TOLERANCE: - DURATION: 50000H			
				
DEVICE SPECIFICATIONS	TYPE OF EMISSION: DIFFUSED POWER: 120 W FLOW LAMP: 12006 lm BEAM ANGLE: - DEVICE EFFICIENCY: 100.1lm/W IMPACT RESISTENCE: - GLOW WIRE TEST: -		POWER SUPPLY CABLE LENGTH: 400cm LENGTH OF HANGING CABLE: 350cm SUPPLY: INCLUDED POWER SUPPLY ASSEMBLY: - TYPE OF DIMMING: PUSH/DALI VOLTAGE: 230 V	
	POWER SUPPLY: ELECTRONIC DIMMABLE POWER SUPPLY			
CERTIFICATIONS	   			
MARKETS	THIS ITEM IS AVAILABLE IN THE FOLLOWING COUNTRIES: EUROPE			

GLOUGLOU

code: *2044/85/DIM/L/1/AR*

DESIGN EMILIANA MARTINELLI 2007

TECHNICAL DRAWINGS

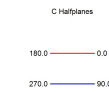
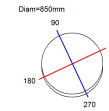
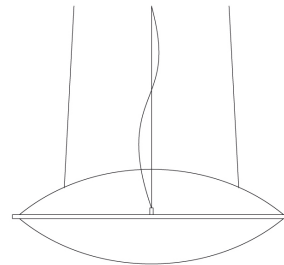
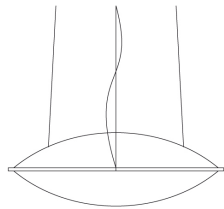

Flux 12000.00 lm
Maximum 143.00 cd/klm
Position C=0.00 G=0.00
Efficiency 100.05%
Date: 24-10-2016
Double Symmetrical

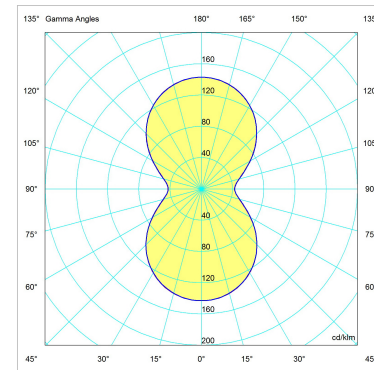

PHOTO GALLERY



GLOUGLOU

code: **2044/85/DIM/L/1/TR**

DESIGN EMILIANA MARTINELLI 2007



HANGING LAMP FOR DIFFUSED LIGHT, FORMED BY A SATIN WHITE OPAL METHACRYLATE DIFFUSER AND A CENTRAL RING OF TRANSPARENT OR ORANGE COLOR METHACRYLATE. LED LIGHT SOURCE INTEGRATED. ELECTRONIC DRIVERS DIMMABLE INCLUDED.

TECHNICAL DRAWINGS

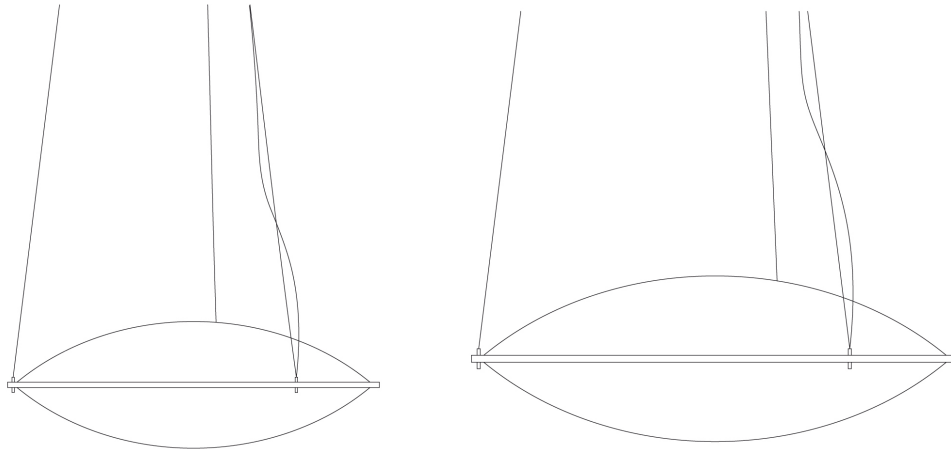

UTILIZATION:	INTERNAL	TPOLOGY:	HANGING	
COLOURS	STRUCTURE: DIFFUSER:	WHITE TRANSPARENT		
MATERIALS	STRUCTURE: DIFFUSER:	METHACRYLATE		
MEASURES	WIDTH: - HEIGHT: - LENGTH: - DEPTH: -	DIAMETER: 85 cm HOLE DIAMETER: - HOLE DEPTH: -	WEIGHT NET: 6,5 GROSS: 8,5	
	PACKAGING VOL.M ³ : 100X100X40		NUMBER OF ITEMS: 1	
BULBS	LED 1X120W FLUX: 7500LM KELVIN: 3000° CLASS: A++ CRI: >80 COLOR TOLERANCE: - DURATION: 50000H			
				
DEVICE SPECIFICATIONS	TYPE OF EMISSION: DIFFUSED POWER: 120 W FLOW LAMP: 12006 lm BEAM ANGLE: - DEVICE EFFICIENCY: 100.1lm/W IMPACT RESISTENCE: - GLOW WIRE TEST: -		POWER SUPPLY CABLE LENGTH: 400cm LENGTH OF HANGING CABLE: 350cm SUPPLY: INCLUDED POWER SUPPLY ASSEMBLY: - TYPE OF DIMMING: PUSH/DALI VOLTAGE: 230 V	
	POWER SUPPLY: ELECTRONIC DIMMABLE POWER SUPPLY			
CERTIFICATIONS				
MARKETS	THIS ITEM IS AVAILABLE IN THE FOLLOWING COUNTRIES: EUROPE			

GLOUGLOU

code: *2044/85/DIM/L/1/TR*

DESIGN EMILIANA MARTINELLI 2007

TECHNICAL DRAWINGS

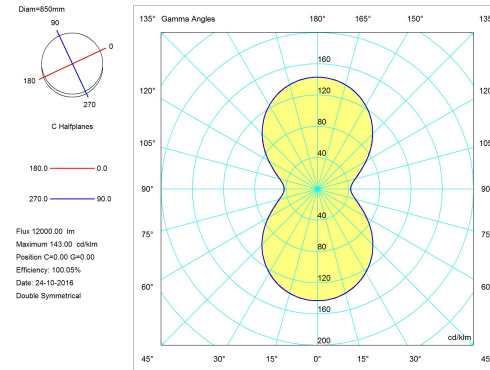
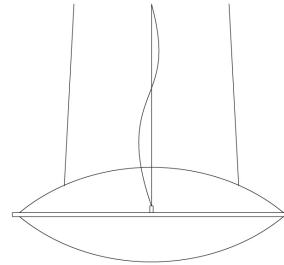
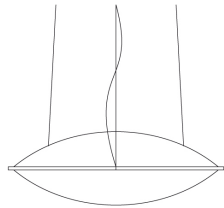

PHOTO GALLERY

