

LASER BLADE XL ADJUSTABLE MINIMAL/FRAME LED

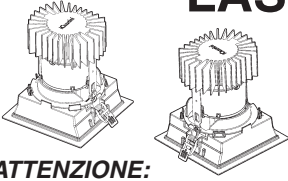

ATTENZIONE:

LA SICUREZZA DELL'APPARECCHIO E' GARANTITA SOLO CON L'USO APPROPRIATO DELLE SEGUENTI ISTRUZIONI; PERTANTO E' NECESSARIO CONSERVARLE.

GB WARNING:

THE SAFETY OF THIS FIXTURE IS GUARANTEED ONLY IF YOU COMPLY WITH THESE INSTRUCTIONS; REMEMBER TO CONSERVE IN A SAFE PLACE.

F ATTENTION:

LA SECURITE DE L'APPAREIL N'EST GARANTIE QU'EN CAS D'UTILISATION CORRECTE DES INSTRUCTIONS SUIVANTES; IL FAUT PAR CONSEQUENT LES CONSERVER.

D ACHTUNG:

DIE SICHERHEIT DES GERÄTES WIRD NUR DURCH SACHGEMÄSSE BEFOLGUNG NACHSTEHENDER ANWEISUNGEN GEWÄHRLEISTET; IHRE AUFBEWAHRUNG IST DESHALB SEHR WICHTIG.

NL OPGELET:

DE VEILIGHEID VAN DI ATOESTEL IS SLECHTS DAN GEGARANDEERD ALS INDIEN DE VOLGENDE INSTRUCTIES STRIKT WORDEN TOEGEPAST: DAAROM MOET MEN ZE OOK BEWAREN.

E ATENCION:

LA SEGURIDAD DEL APARATO SE GARANTIZA SOLO CUMPLIENDO CUIDADOSAMENTE LAS SIGUIENTES INSTRUCCIONES; POR ELLO, ES NECESARIO CONSERVARLAS.

DK BEMÆRK:

SIKKERHEDEN VED BRUG AF ARMATURET KAN KUN GARANTERES, HVIS DISSE ANVISNINGER FØLGES; SØRG DERFOR FOR AT GEMME DEM.

N ADVARSEL:

SIKKERHETEN TIL DETTE APPARATET GARANTERES KUN HVIS DU OVERHOLDER DISSE INSTRUKSJONENE; HUSK Å OPPBEVARE DEM PÅ ET TRYGT STED.

S OBSERVERA!

UTRUSTNINGENS SÄKERHET KAN ENDAST GARANTERAS OM DESSA ANVISNINGAR RESPEKTERAS I DETALJ. SPARA DÄRFÖR DESSA ANVISNINGAR FÖR FRAMTIDA KONSULTATION.

RUS ВНИМАНИЕ:

МЫ ГАРАНТИРУЕМ БЕЗОПАСНУЮ ЭКСПЛУАТАЦИЮ ИЗДЕЛИЯ ТОЛЬКО ПРИ СОБЛЮДЕНИИ СЛЕДУЮЩИХ ИНСТРУКЦИЙ; С ЭТОЙ ЦЕЛЬЮ НЕОБХОДИМО СОХРАНИТЬ ДАННУЮ БРОШЮРУ.

CN 警告

为确保该装置安全，请遵守操作指示；并于安全场所放置。

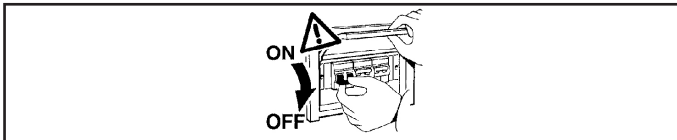

N.B.: DURANTE L'INSTALLAZIONE DEL SISTEMA RISPETTARE SCRUPOLOSAMENTE LE NORME IMPIANTISTICHE VIGENTI.

N.B.: WHEN INSTALLING THE SYSTEM, STRICTLY COMPLY WITH ALL REGULATIONS ON INSTALLATION IN FORCE.

N.B.: LORS DE L'INSTALLATION DU SYSTÈME VEUILLEZ RESPECTER RIGOREUSEMENT LES NORMES EN VIGUEUR EN LA MATIÈRE.

NB: BEACHTEN SIE BEI DER INSTALLATION DES SYSTEMS GEWISSENHAFT DIE GÜLTIGEN BESTIMMUNGEN BEZÜGLICH DER ANLAGENTECHNIK.

N.B.: BIJ HET INSTALLEREN VAN HET SYSTEEM MOET U DE GELDENDE INSTALLATIENORMEN STRIKT NALEVEN.

N.B.: DURANTE LA INSTALACIÓN DEL SISTEMA RESPETAR E SCRUPULOSAMENTE LAS NORMAS DE INSTALACIÓN VIGENTES.

N.B.: UNDER INSTALLATION AF SYSTEMET SKAL MAN NØJE OVERHOLDE DE GÆLDENDE REGLER FOR DISSE ANLÆG.

N.B.: VED INSTALLASJON AV SYSTEMET SKAL ALLE FORSKRIFTER OM INSTALLASJON SOM GJELDER FØLGES STRENGT.

OBS! UNDER INSTALLATIONEN AV SYSTEMET SKA INSTALLATIONSFÖRESKRIFTERNA RESPEKTERAS I DETALJ.

ПРИМЕЧАНИЕ: В ПРОЦЕССЕ МОНТАЖА СИСТЕМЫ СТРОГО СОБЛЮДАЙТЕ НАЦИОНАЛЬНЫЕ ДЕЙСТВУЮЩИЕ НОРМАТИВЫ ПО ЭЛЕКТРОПРОВОДКЕ.

注意：在安装系统时请遵守设备的安装规定。

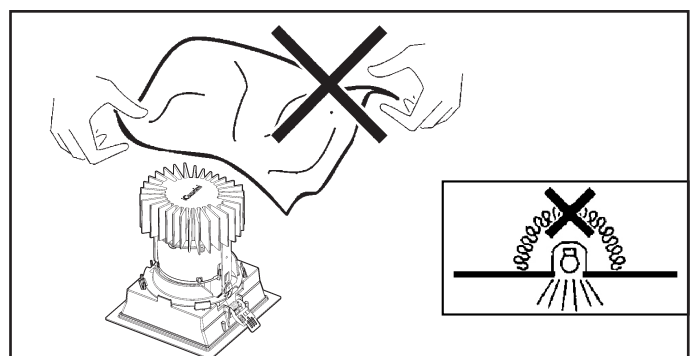
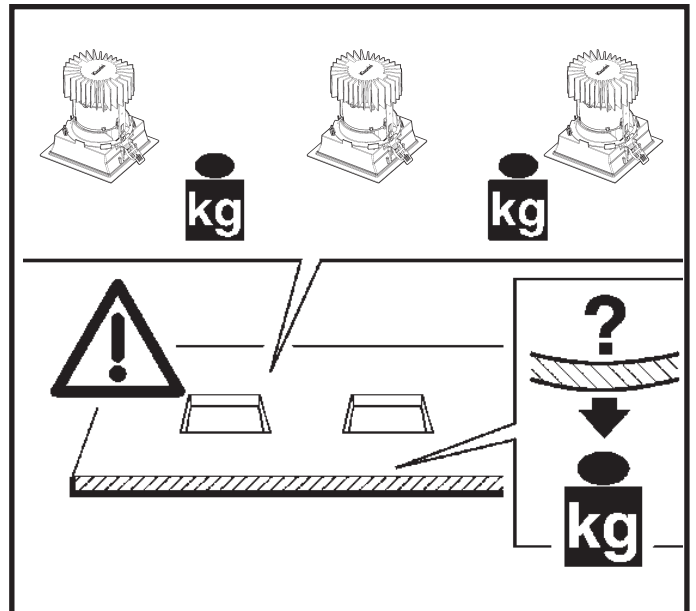
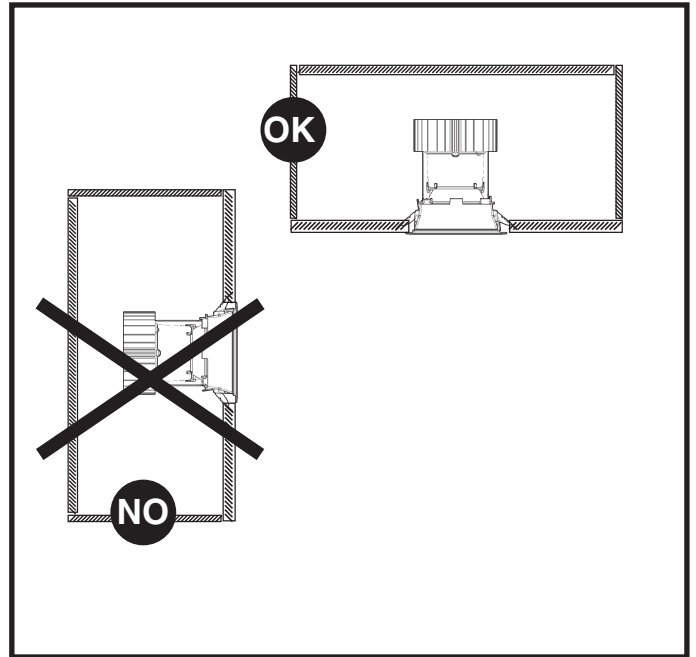

I N.B.: Apparecchi non idonei ad essere coperti di materiale termicamente isolante

GB N.B.: Fixtures not suitable to be covered in thermally-insulating material.

F N.B.: Appareils ne pouvant pas être couverts de matériau d'isolation thermique

D N.B.: Geräte nicht geeignet, um mit wärmeisolierendem Material abgedeckt zu werden

NL N.B.: Deze apparaten zijn niet geschikt om te worden bedekt met thermisch isolerend materiaal

E NOTA: Aparatos no aptos para ser cubiertos de material térmicamente aislante

DK N.B.: Armaturerne må ikke dækkes af varmeisolerende materiale.

N N.B.: Apparaten passer ikke til å dekkes av termoisolerende materialer.

S OBS! Utrustningen får inte täckas över med värmeisolerande material

RUS Внимание: Приборы непригодны для покрытия термоизоляционным материалом.

CN 灯具不适宜用隔热材料加以覆盖。

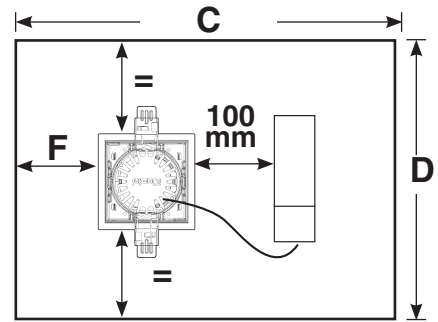
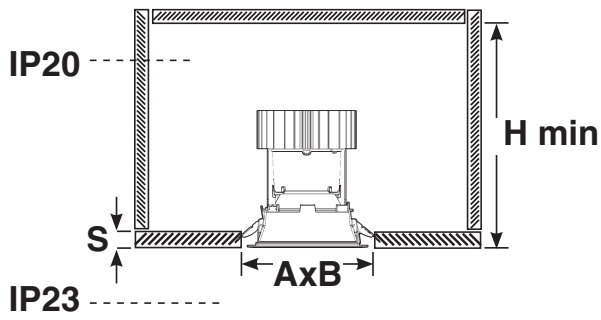
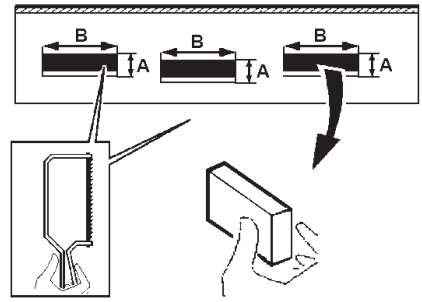
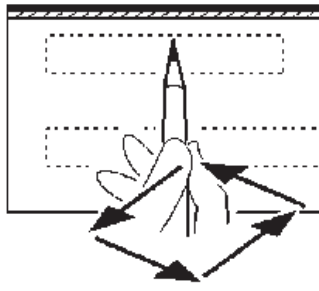

ART	+2 -0 Ax B mm	C mm	D mm	F mm	H mm	S mm
P758 - P760 - P761 - P762 - P764 - P765 - P766	125 x 125	500	500	50	200	1 ÷ 25
P759 - P763					150	
P767 - P769 - P770 - P771 - P773 - P774 - P775				50	200	12 ÷ 25
P768-P772	150					

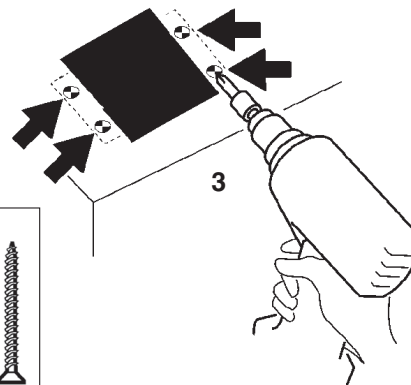
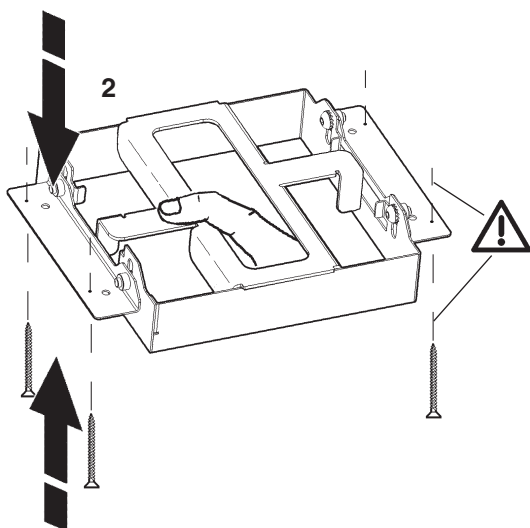
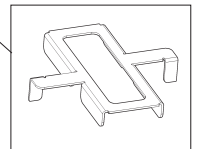
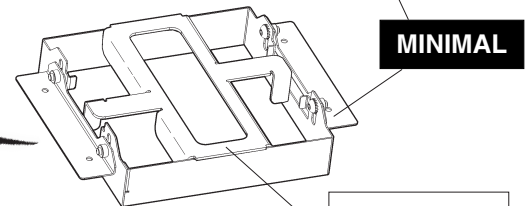
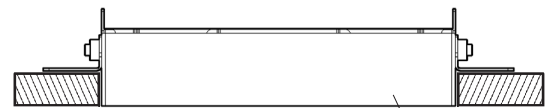
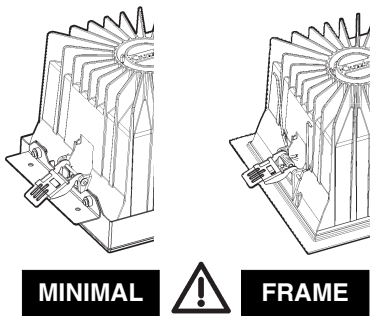

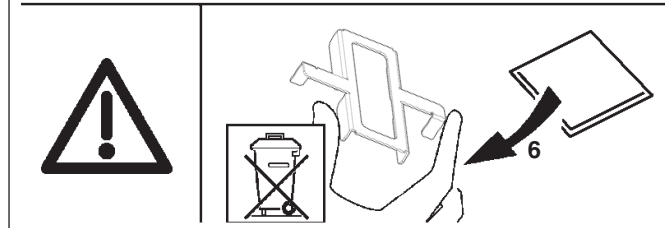
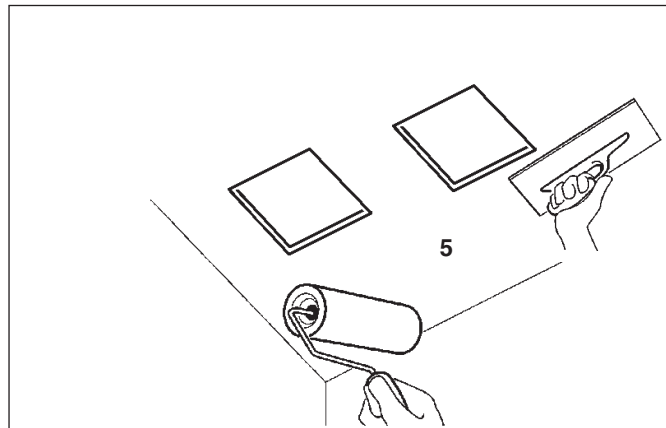
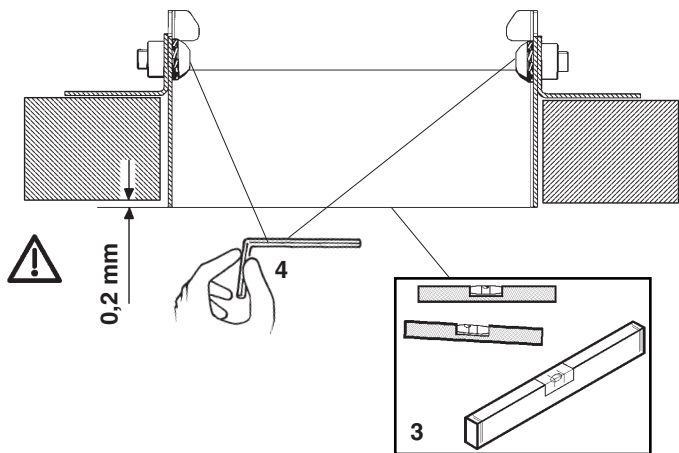
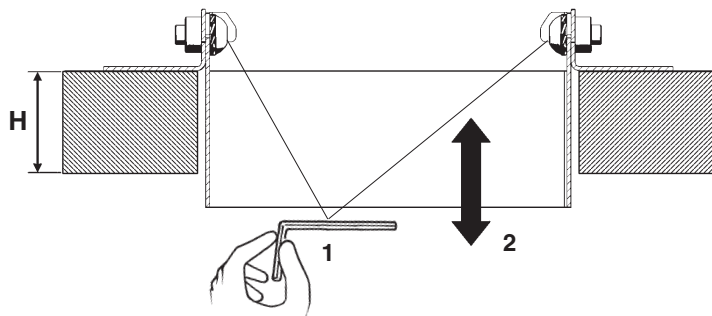

- I Cablare alla rete elettrica il trasformatore solo dopo aver effettuato il collegamento ai prodotti
- GB Wire the transformer to the electrical mains only after the connection to the products has been carried out
- F N'effectuer le câblage au réseau électrique qu'après avoir effectué le raccordement aux produits
- D Schließen Sie den Transformator erst nach der Verdrahtung an den Produkten am Stromnetz an.
- E Cablear el transformador a la red eléctrica sólo después de conectar los productos
- NL Verbind de transformator alleen op het elektrische net nadat u alle producten heeft aangesloten.
- DK Tilslut først transformatoren til strømforsyningsnettet, efter at have foretaget tilslutningen til produkterne.
- N Omformeren skal kun kobles til strømmettet etter at tilkoblingen til produktene er gjennomført.
- S Anslut transformatorn till elnätet först efter att anslutningen till produkterna har utförts.
- RUS Подвести кабель трансформатора к электрической сети, только после соединения с продуктами
- CN 只有连接灯具后，才可以把变压器连接到电源线上。

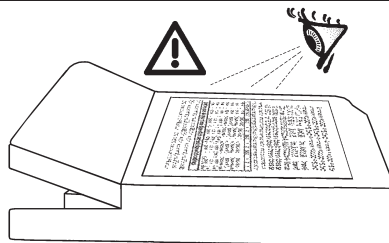
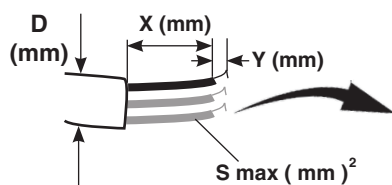

- I Per il collegamento elettrico fare riferimento alla marcatura dell'alimentatore.
- GB Refer to the marking on the power unit for the electrical connection.
- F Pour le raccordement électrique se reporter au marquage du ballast.
- D Den Anschluss an das Stromnetz gemäß Kennzeichnung auf dem Vorschaltgerät ausführen.
- NL Voor de elektrische aansluiting wordt verwezen naar de markering op de stroomvoorziening.
- E Para la conexión eléctrica hacer referencia a las informaciones marcadas en el alimentador.
- DK For elektrisk tilslutning, se strømforsynings mærkning.
- N For elektrisk tilkobling, se merking på strømforsyningsenheten.
- S För elanslutningen se till märkningen på nåtdelen.
- RUS Для электрического подключения смотреть маркировку на блоке питания.
- CN 连接电线时请参照供电装置上的标记。

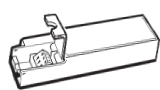
	S mm ²	Y mm	X mm	D mm
TRIDONIC LCA	0,2 - 1,5	8,5 ± 9,5	~ 40	/
OSRAM OT i DALI	0,5 - 1,5	8 ~ 9		7 - 11
PHILIPS Xitanim LH	0,2 - 1,5	9 ± 0,5	~ 30	/
PHILIPS Xitanim Mini	0,5 - 1,5	8,5 ± 9,5	~ 25	/

DALI

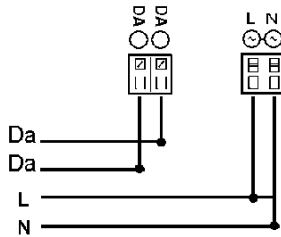

TOUCH DIM

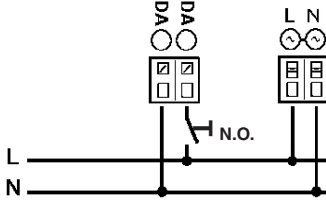

I I dispositivi con cablaggio digitale possono essere dimmerati con dispositivi DALI o con pulsante normalmente aperto (N.O.) da collegare come da schema.

GB Devices with digital control gear may be dimmed using DALI devices or a normally-open button (N.O.) to be connected as shown in the diagram.

F Les articles à câblage numérique peuvent fonctionner avec des variateurs à dispositifs DALI ou à bouton poussoir normalement ouvert (N.O.) à relier conformément au schéma.

D Die Geräte mit digitaler Verkabelung können mit Hilfe von DALI-Vorrichtungen oder mit Hilfe eines gemäß Schaltplan anzuschließenden Schließers (N.O.) gedimmt werden.

E De producten met digitale bekabeling kunnen worden gedimd met DALI systemen of met een N.O. (normally open) knop, die moet worden aangesloten volgens schema.

DK Los dispositivos con cableado digital pueden regularse con dispositivos DALI o con un interruptor de botón normalmente abierto (N.O.) que se conecta según ilustrado en el esquema.

N Produkter med digital kabelföring kan dämpas med DALI-anordningar eller med kontakten, som normalt er åben (N.O.) og som skal tilsluttes, som vist.

S Produkter med digitalkabler kan dimmes med DALI-anordninger eller med en normalt åpen (NO) trykkbryter som kobles som vist i koblingsskjema.

RUS Produkter med digital kabeldragning kan förses med dimmer. Detta kan göras med DALI-anordningarna eller med en normalt öppen kontakt (N.O.) som ska anslutas enligt schemat.

CN 亮度强度 器具 的 数字 线路 可以 通过 DALI 或 正常 打开 按钮 (N.O.) 进行 亮度 调节。

I Pilotare diversi prodotti DALI tramite pulsante (es: Touch-dim, Switch-dim, Push-dim, Direct-dim, etc.) potrebbe causare dei problemi di sincronizzazione tra gli stessi. È possibile ovviare a questo problema dotandosi di dispositivi aggiuntivi. Per maggiori informazioni vi invitiamo a contattarci direttamente.

GB Controlling different DALI products through buttons (e.g.: Touch-dim, Switch-dim, Push-dim, Direct-dim, etc.) may lead to product synchronisation problems. This problem can be overcome by using additional devices. For further information, please contact us directly.

F Pilote plusieurs produits DALI par bouton (ex : Touch-dim, Switch-dim, Push-dim, Direct-dim, etc.) pourrait causer des problèmes de synchronisation entre eux. Ce problème peut être évité en s'équipant de dispositifs supplémentaires. Pour de plus amples renseignements, veuillez nous contacter directement.

D Die Steuerung verschiedener DALI-Produkte mittels Taste (z.B.: Touch-dim, Switch-dim, Push-dim, Direct-dim etc.) kann eventuell zu Synchronisierungsproblemen zwischen diesen führen. Dieses Problem lässt sich durch den Einsatz von zusätzlichen Geräten beheben. Wenn Sie weitere Informationen wünschen, setzen Sie sich bitte direkt mit uns in Verbindung.

NL Het besturen van verschillende DALI producten m.b.v. dezelfde knop (bv.: Touch-dim, Switch-dim, Push-dim, Direct-dim, etc.) kan synchronisatieproblemen tussen de producten opleveren. Men kan dit probleem voorkomen door extra systemen aan te sluiten. Voor verdere informatie raden we u aan direct contact met ons op te nemen.

E El mando de varios productos DALI por tecla (ej: Touch-dim, Switch-dim, Push-dim, Direct-dim, etc.) podría causar problemas de sincronización entre ellos. Es posible prevenir este problema utilizando dispositivos adicionales. Para más información, contacte directamente con nosotros.

DK Hvis DALI-produkterne styres ved hjælp af knapperne (fx. Touch-dim, Switch-dim, Push-dim, Direct-dim osv.), kan det skabe problemer med synkronisering af samme. Dette problem kan undgås, hvis man køber ekstra enheder. For yderligere oplysninger, kontakt os direkte.

N Å styre ulike DALI-produkter ved hjelp av en trykknappbryter (f.eks. touch-dim, switch-dim, push-dim, direct-dim, osv.) vil kunne føre til problemer med synkroniseringen mellom dem. Dette problemet kan løses ved hjelp av noen tilleggsinnretninger. Ta gjerne kontakt med oss for mer informasjon om dette.

S Styrning av olika DALI-produkter med knapp (t.ex.: Touch-dim, Switch-dim, Push-dim, Direct-dim o.s.v.) kan orsaka synkroniseringsproblem mellan dessa. Detta problem kan åtgärdas med tillägsanordningar. För mer information kan du kontakta oss direkt.

RUS Управление различными продуктами DALI с помощью кнопки (напр.: Touch-dim, Switch-dim, Push-dim, Direct-dim и пр.) может вызвать проблемы синхронизации между ними. Эту проблему можно устранить путем задействования дополнительных устройств. За получением более подробной информации просим Вас связаться с нами непосредственно.

CN 通过按钮控制不同的 DALI 产品 (例如: 触摸调光、切换调光、按压调光、直接调光等) 可能会导致产品的同步问题。该问题可通过使用其他额外的装置加以克服。如需了解更多信息, 请直接与我们联系。

ART.	CARICO DALI / DALI LOAD CHARGE DALI (COURANT MAXI ADMISSIBLE) DALI-LAST DALI VERMOGEN CARGA DALI DALI STRØMSTYRKE BELASTNING FOR "DALI" DALI-BELASTNING МАКС. ТОК СИСТЕМЫ DALI С РЕГУЛЯЦИЕЙ ИНТЕНСИВНОСТИ СВЕТА DALI 智能调光系统允许的最大电流量	INDIRIZZI DALI DALI ADDRESSES ADRESSES DALI DALI-ADRESSEN DALI ADRESSEN DIRECCIONES DALI DALI ADRESSER ADRESSER TIL "DALI" DALI-ADRESSER ЛОГИЧЕСКИЕ АДРЕСА СИСТЕМЫ DALI DALI智能调光系统计算机指定控制参数
	2mA	1

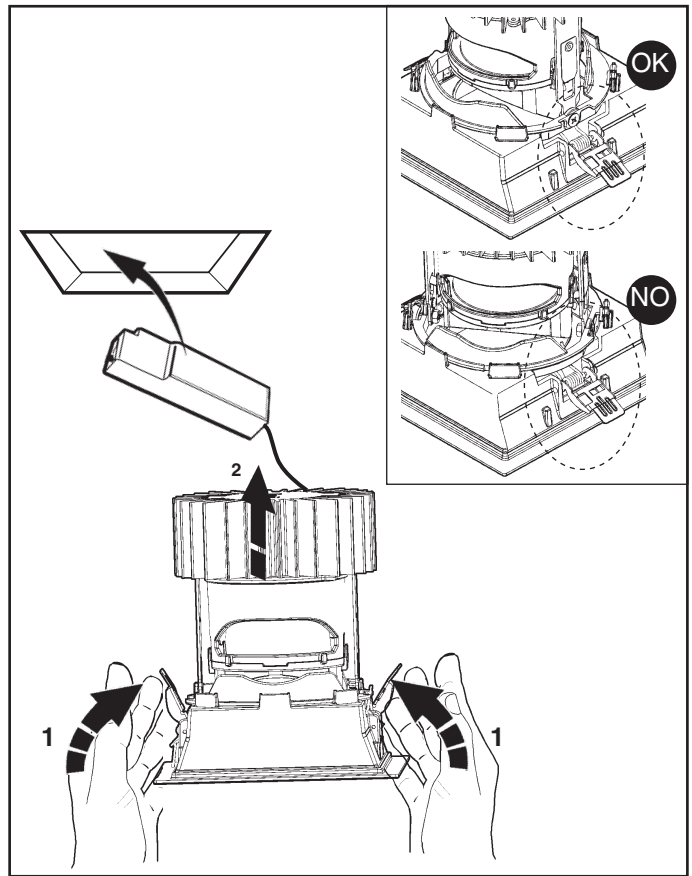

INSTALLAZIONE DEGLI ACCESSORI - INSTALLING THE ACCESSORIES
INSTALLATION DES ACCESSOIRES - INSTALLATION DER ZUBEHÖRE
INSTALLATIE VAN DE ACCESSOIRES - INSTALACION DE LOS ACCESORIOS
INSTALLATION AF TILBEHØR - INSTALLERING AV TILBEHØRET - INSTALLATION AV TILLBEHÖR
МОНТАЖ ВСПОМОГАТЕЛЬНЫХ КОМПЛЕКТУЮЩИХ - 附件的安装

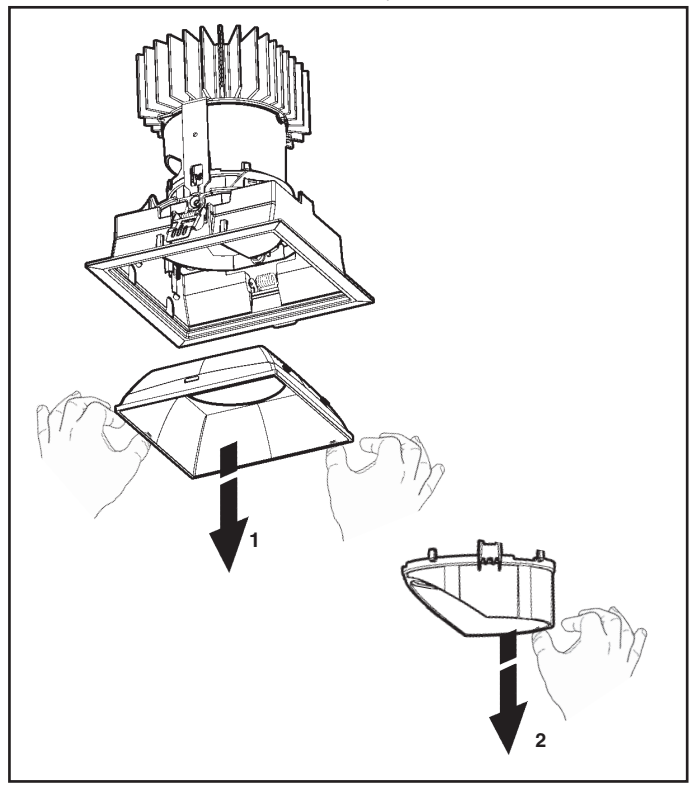

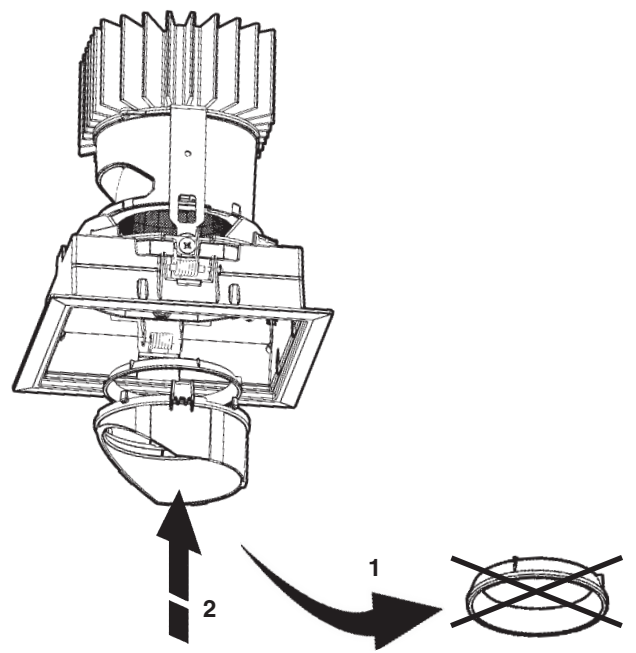
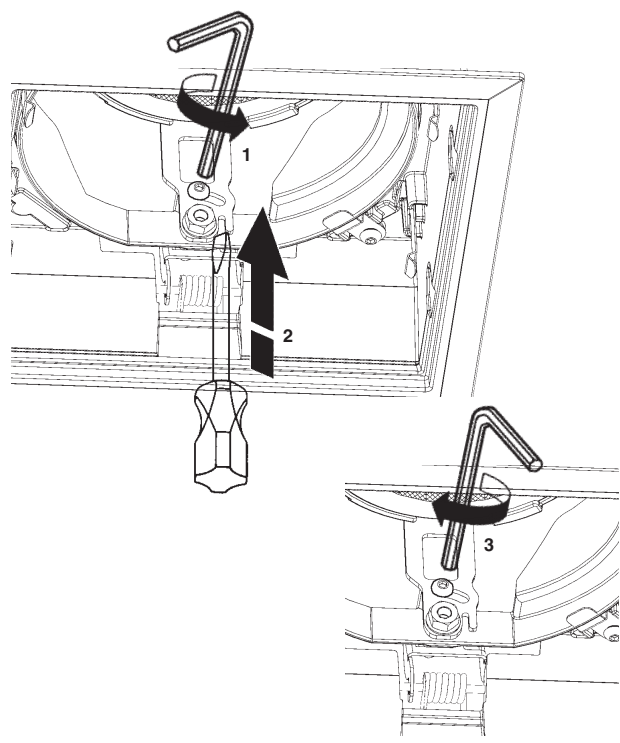
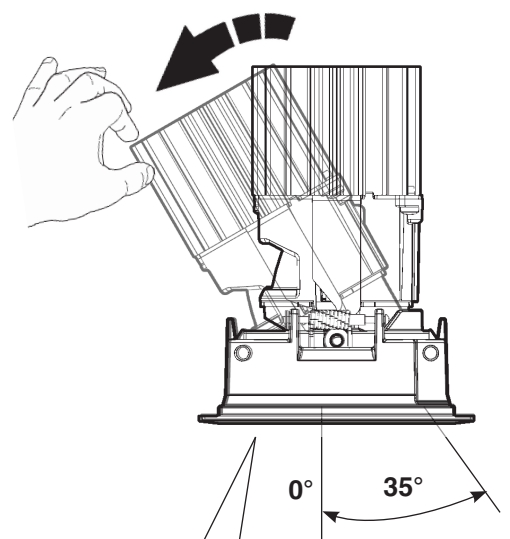
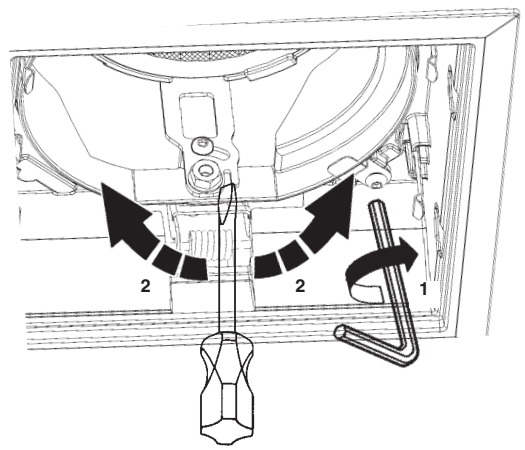
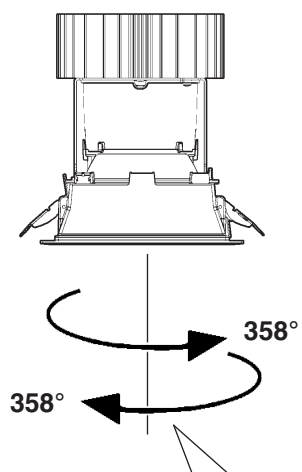
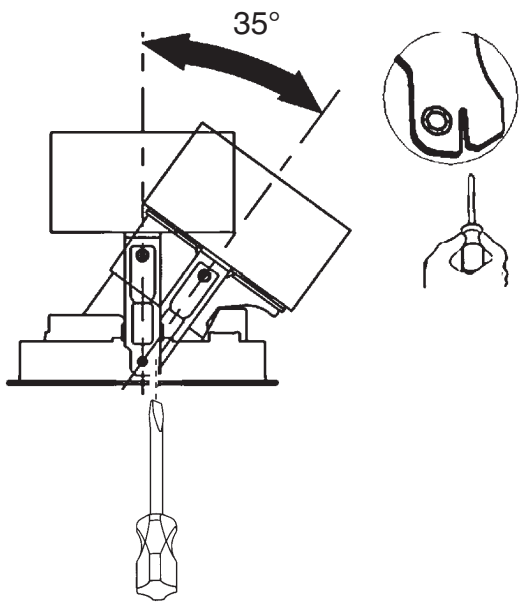

+ art. MXV1

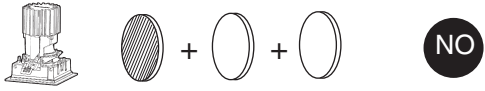
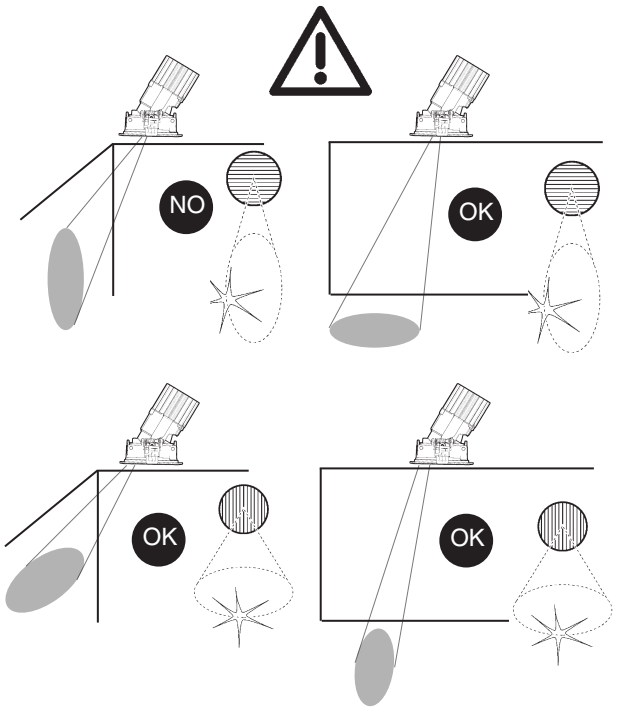
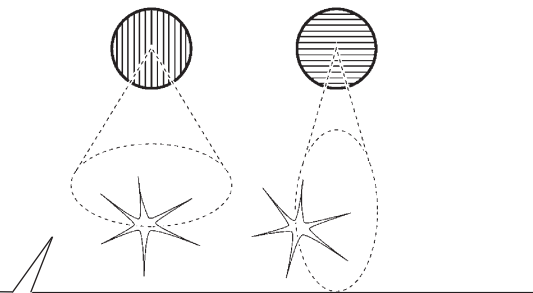
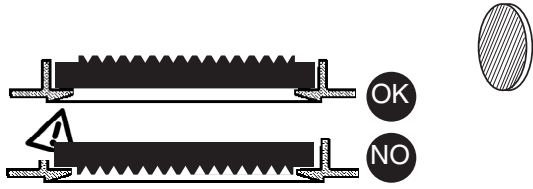

+ art. MY47 - MY48 - MY49

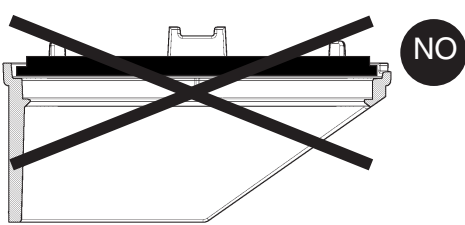
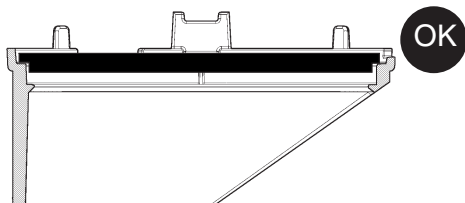

+ art. MY38

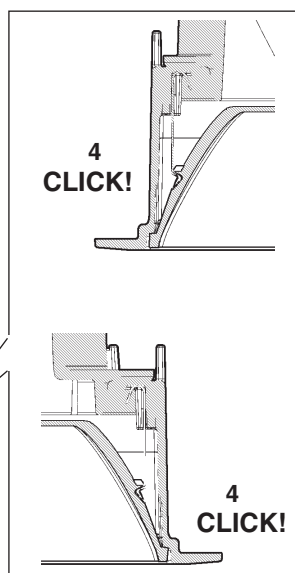
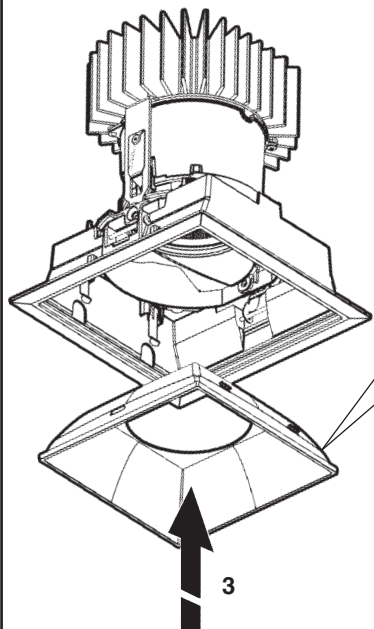
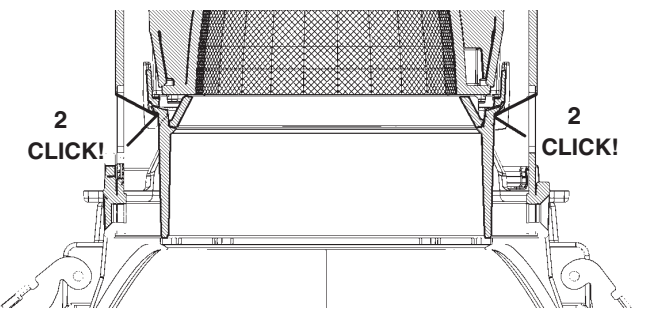
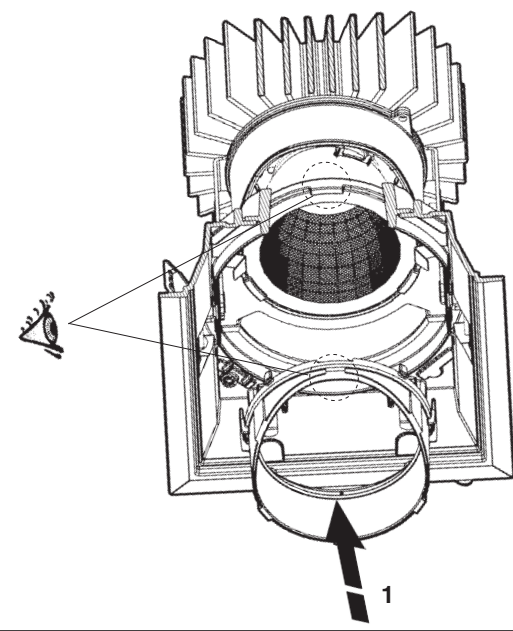
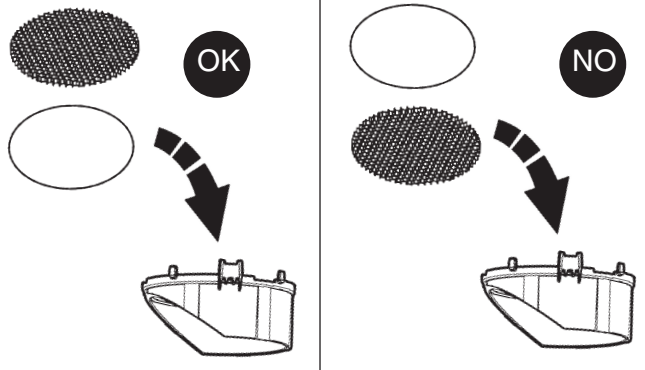

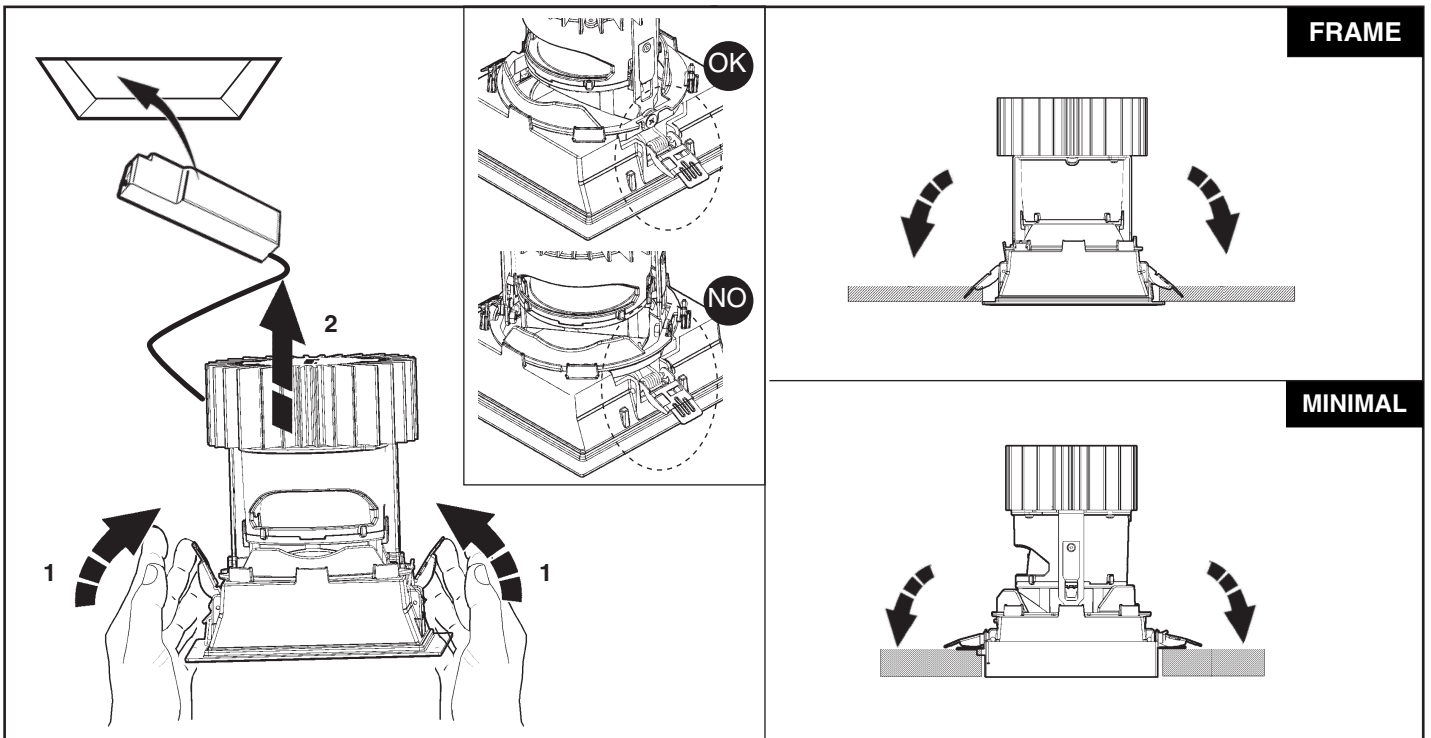

ART.	art. MY38	art. MXV1	art. 4491	art. MY46	art. MY50			art. MY47	art. MY48	art. MY49
					.05	.06	.16			
P758	✓	✓	✓	✓	✗	✓	✗	✗	✗	✗
P759	✓	✓	✓	✓	✓	✓	✓	✓	✓	✓
P760	✓	✓	✓	✓	✗	✓	✗	✗	✗	✗
P761	✓	✓	✓	✓	✗	✓	✗	✗	✗	✗
P762	✓	✓	✓	✓	✗	✓	✗	✗	✗	✗
P763	✓	✓	✓	✓	✓	✓	✓	✓	✓	✓
P764	✓	✓	✓	✓	✗	✓	✗	✗	✗	✗
P765	✓	✓	✓	✓	✗	✓	✗	✗	✗	✗
P766	✓	✓	✓	✓	✗	✓	✗	✗	✗	✗
P767	✓	✓	✓	✓	✗	✓	✗	✗	✗	✗
P768	✓	✓	✓	✓	✓	✓	✓	✓	✓	✓
P769	✓	✓	✓	✓	✗	✓	✗	✗	✗	✗
P770	✓	✓	✓	✓	✗	✓	✗	✗	✗	✗
P771	✓	✓	✓	✓	✗	✓	✗	✗	✗	✗
P772	✓	✓	✓	✓	✓	✓	✓	✓	✓	✓
P773	✓	✓	✓	✓	✗	✓	✗	✗	✗	✗
P774	✓	✓	✓	✓	✗	✓	✗	✗	✗	✗
P775	✓	✓	✓	✓	✗	✓	✗	✗	✗	✗

SOSTITUZIONE DEL LED
 REPLACING THE LED
 REMPLACEMENT DE LA LED
 AUSTAUSCHEN DER LED
 VERVERGEN VAN DE LED
 REEMPLAZO DEL LED
 UDSKIFTNING AF LYSDIODE
 BYTE AV LYSDIOD
 UTSKIFTNING AV DEN LYSEMITTERENDE DIODEN
 Замена светодиода
 发光二极管替换

I N.B.: Per la sostituzione del LED contattare l'azienda iGuzzini.
 GB N.B.: For information on LED replacement please contact iGuzzini.
 F N.B.: Pour procéder au remplacement de la LED, adressez-vous à la société iGuzzini.
 D Ñ.B.: Bezüglich des Austausches der LED kontaktieren Sie bitte die Firma iGuzzini.
 NL N.B.: Voor het vervangen van de LED neemt u contact op met het bedrijf iGuzzini.
 E NOTA: Para sustituir el LED llame a la empresa iGuzzini.
 DK N.B.: For udskiftning af lysdioden, skal man kontakte iGuzzini.
 N N.B.: For informasjon om skifte av LED, vennligst ta kontakt med iGuzzini.
 S OBS! För byte av lysdioden, kontakta företaget iGuzzini.
 RUS ПРИМЕЧАНИЕ: Для замены СИДов обращайтесь в компанию iGuzzini.
 CN 注意：如需LED更换的信息，请联系iGuzzini。



I In caso di rottura del vetro il prodotto non può essere utilizzato, contattare il costruttore per la sua sostituzione.
 GB Should the glass break, the product cannot be used and you should contact the manufacturer for its replacement.
 F En cas d'endommagement de l'écran de protection le produit ne peut pas être utilisé, contactez le fabricant pour le remplacement.
 D Falls das Glas kaputt sein sollte, kann das Produkt nicht verwendet werden. Kontaktieren Sie in dem Fall den Hersteller, um das Glas zu ersetzen.
 NL Als het glas gebroken is kan het apparaat niet worden gebruikt en moet u zich tot de fabrikant wenden voor het vervangen van het glas.
 E No utilizar el producto en caso de ruptura del vidrio y contactar el fabricante para la sustitución.
 DK Hvis produktets glas ødelægges, kan det ikke anvendes. Kontakt forhandleren med henblik på udskiftning.
 N Hvis glasset skulle knuses, kan ikke produktet brukes, og du må ta kontakt med produsenten for å få det skiftet.
 S Om glaset går sönder kan inte produkten användas. Kontakta tillverkaren för att byta ut glaset.
 RUS В случае разбивания стекла не используйте прибор, обратитесь к его производителю для замены.
 CN 且玻璃破碎后产品将不能再使用，须联系生产商予以更换。

2.509.498.00
IS11855/00

iGuzzini

LASER BLADE XL ADJUSTABLE MINIMAL/FRAME LED

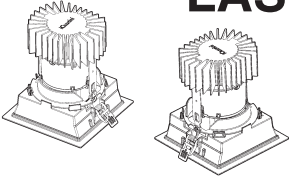

تحذير:

لا يمكن ضمان سلامة هذا الجهاز إلا إذا التزمت بهذه التعليمات. يجب حفظها في مكان آمن.

ATTENZIONE:

LA SICUREZZA DELL'APPARECCHIO E' GARANTITA SOLO CON L'USO APPROPRIATO DELLE SEGUENTI ISTRUZIONI; PERTANTO E' NECESSARIO CONSERVARLE.

WARNING:

THE SAFETY OF THIS FIXTURE IS GUARANTEED ONLY IF YOU COMPLY WITH THESE INSTRUCTIONS; REMEMBER TO CONSERVE IN A SAFE PLACE.

ATENCION:

LA SEGURIDAD DEL APARATO SE GARANTIZA SOLO CUMPLIENDO CUIDADOSAMENTE LAS SIGUIENTES INSTRUCCIONES; POR ELLO, ES NECESARIO CONSERVARLAS.

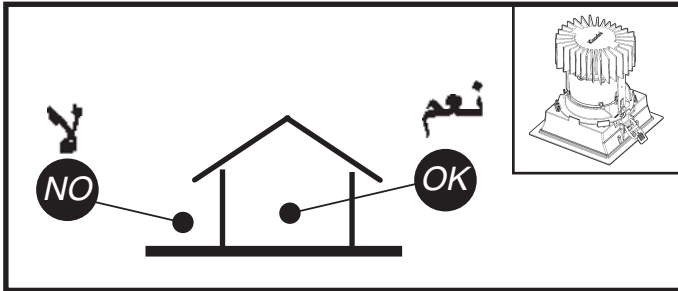
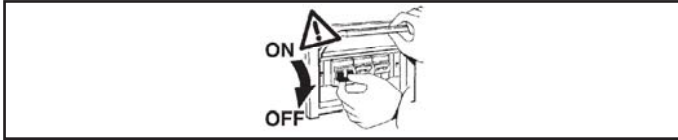

ملاحظة: ملاحظة: أثناء تركيب نظام . يجب التقيد بحرص بالنظم السائدة المتعلقة بالشبكة الكهربائية.

N.B.: DURANTE L'INSTALLAZIONE DEL SISTEMA RISPETTARE SCRUPolosAMENTE LE NORME IMPIANTISTICHE VIGENTI.
N.B.: WHEN INSTALLING THE SYSTEM STRICTLY COMPLY WITH ALL REGULATIONS ON INSTALLATION IN FORCE.
N.B.: DURANTE LA INSTALACIÓN DEL SISTEMA RESPETAR ESCRUPolosAMENTE LAS NORMAS DE INSTALACIÓN VIGENTES.

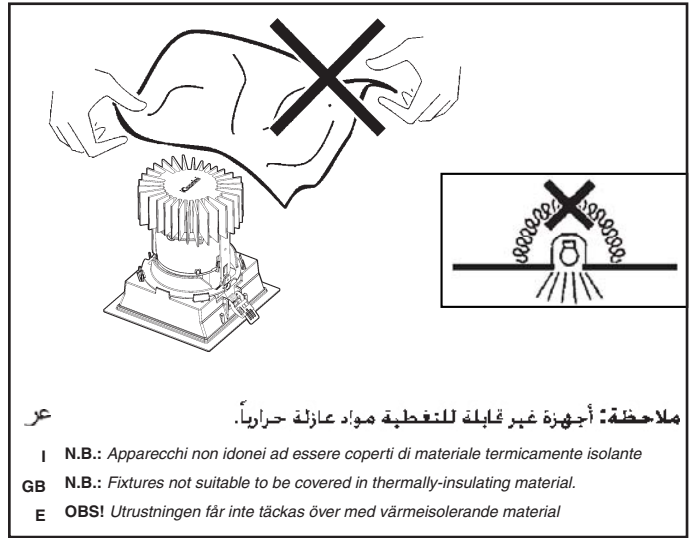
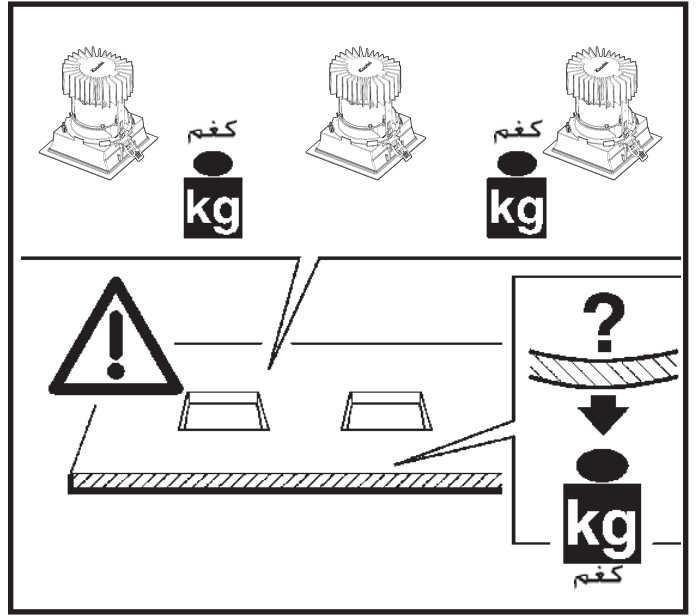
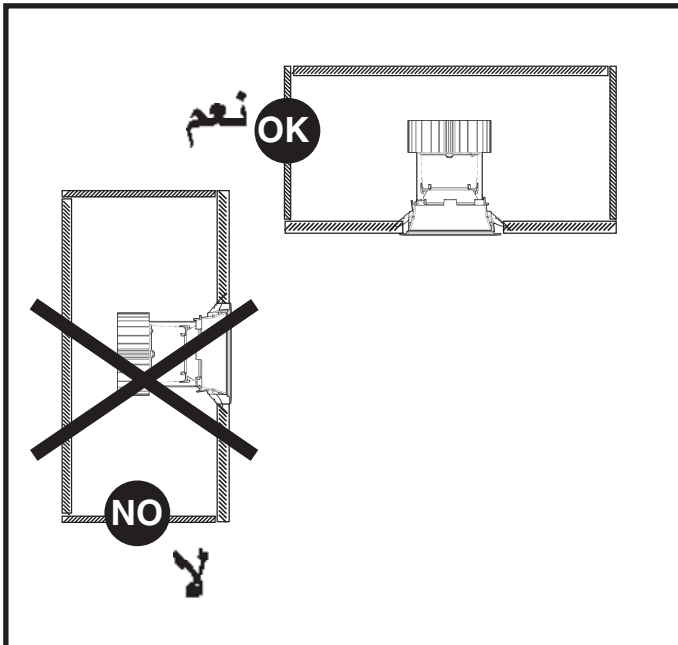

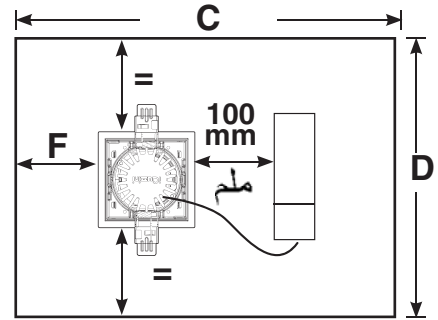
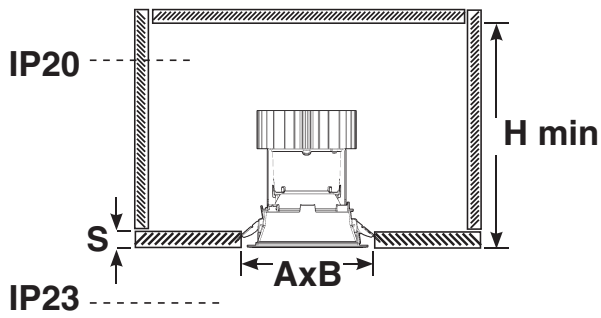
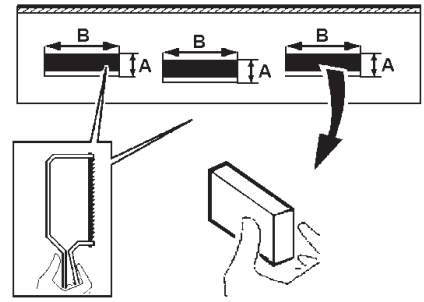
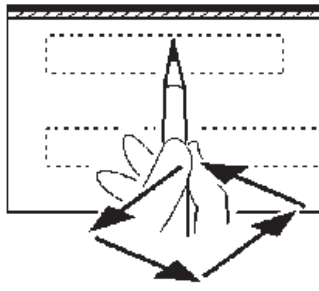

الصنف ART	$\begin{matrix} +2 \\ -0 \end{matrix}$ Ax B مم mm	C مم mm	D مم mm	F مم mm	H مم mm	S مم mm
P758 - P760 - P761 - P762 - P764 - P765 - P766	125 x 125	500	500	50	200	1 ÷ 25
P759 - P763					150	
P767 - P769 - P770 - P771 - P773 - P774 - P775					200	12 ÷ 25
P768-P772					150	

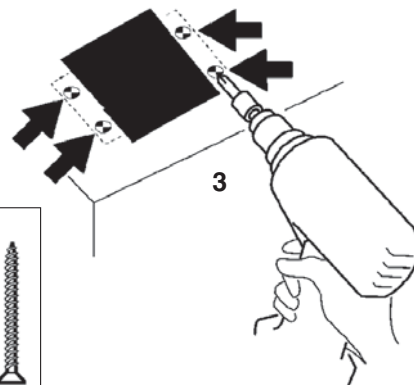
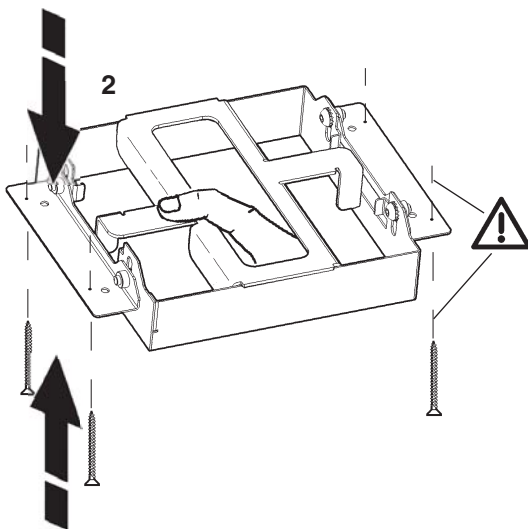
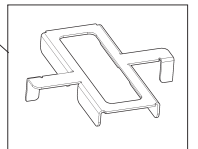
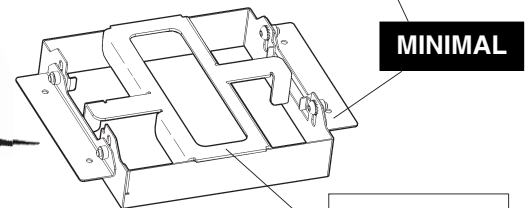
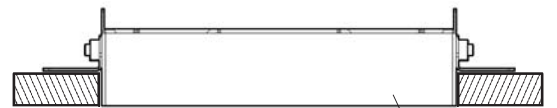
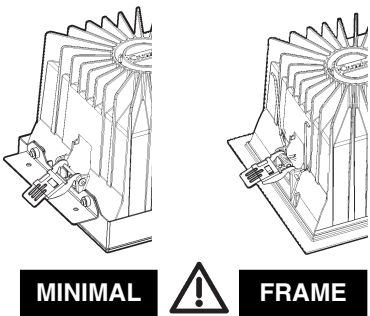

x 4

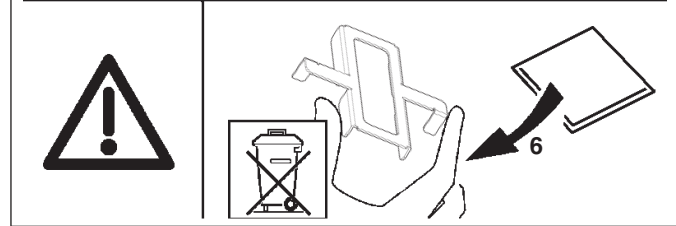
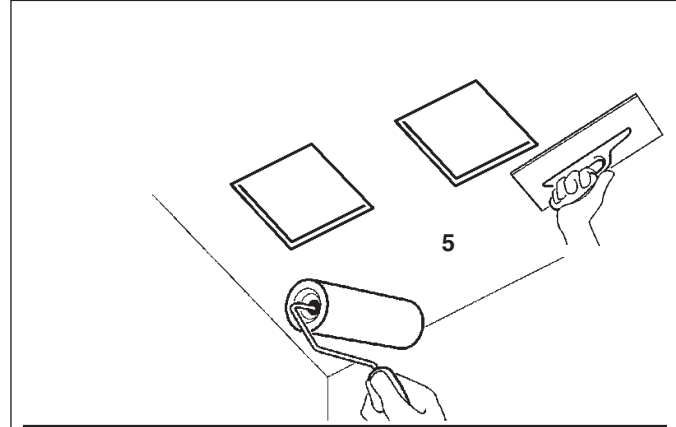
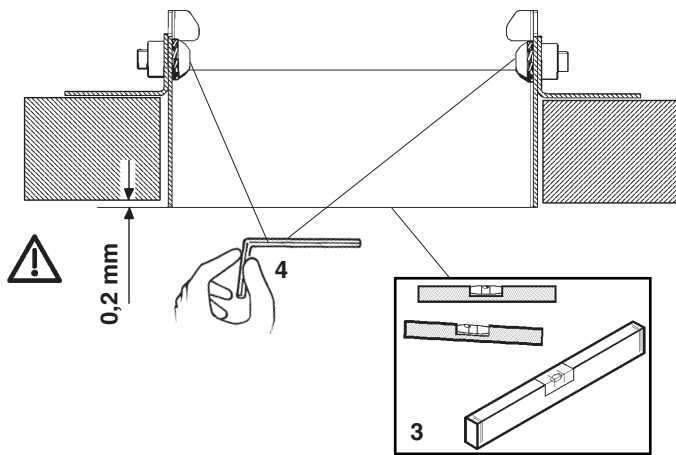
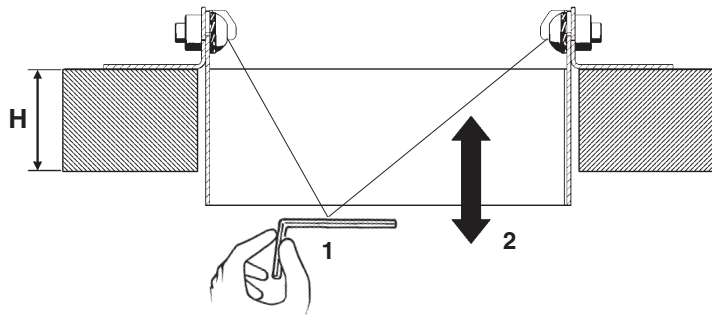

أوصل المحوّل بالشبكة الكهربية فقط بعد توصيل المنتجات.

- I Cablare alla rete elettrica il trasformatore solo dopo aver effettuato il collegamento ai prodotti
- GB Wire the transformer to the electrical mains only after the connection to the products has been carried out
- E Cablear el transformador a la red eléctrica sólo después de conectar los productos

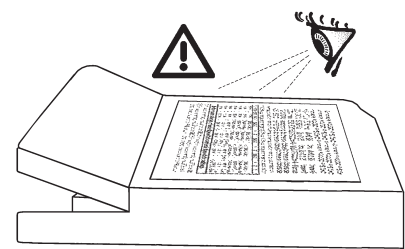
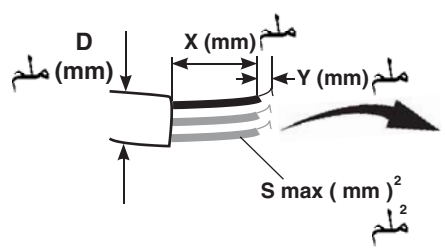

لتوصيل بانكهر باؤ قم بالرجوع إلى العلامات المتواجدة على وحدة التغذية.

- I Per il collegamento elettrico fare riferimento alla marcatura dell'alimentatore.
- GB Refer to the marking on the power unit for the electrical connection.
- E Para la conexión eléctrica hacer referencia a las informaciones marcadas en el alimentador.

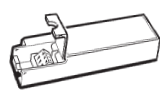
	S mm ² ملم ²	Y mm ملم	X mm ملم	D mm ملم
TRIDONIC LCA	0,2 - 1,5	8,5 ± 9,5	~ 40	/
OSRAM OT i DALI	0,5 - 1,5	8 - 9		7 - 11
PHILIPS Xitanim LH	0,2 - 1,5	9 ± 0,5	~ 30	/

DALI

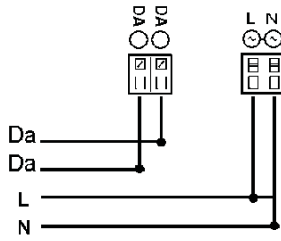

TOUCH DIM

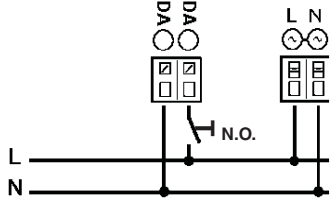

يمكن أن يتم تخفيض إضاءة الأجهزة ذات الكابلات الرقمية؛ وذلك عن طريق استخدام أجهزة الإمداد بالطاقة الكهربائية "دالي" (DALI)، أو عن طريق استخدام زر يكون مفتوحًا في وضعه الطبيعي (N.O.)؛ حيث يتم التوصيل كما هو مبين في المخطط.

I I dispositivi con cablaggio digitale possono essere dimmerati con dispositivi DALI o con pulsante normalmente aperto (N.O.) da collegare come da schema.

GB Devices with digital control gear may be dimmed using DALI devices or a normally-open button (N.O.) to be connected as shown in the diagram.

E Los dispositivos con cableado digital pueden regularse con dispositivos DALI o con un interruptor de botón normalmente abierto (N.O.) que se conecta según ilustrado en el esquema.

يمكن أن يتسبب التحكم في منتجات "دالي" المختلفة عن طريق الأزرار، (مثل الأزرار: "تفتش - ديم"، "بوتنش - ديم"، "بوش - ديم"، "دايركت - ديم"، إلخ)، في حدوث مشاكل تتعلق بعملية التزامن بين هذه الأزرار. وإن كان من الممكن تجنب مثل هذه المشاكل، وذلك عن طريق تزويد بعض الأجهزة الإضافية، ندعوكم للاتصال بنا بالبريد الإلكتروني 445 وذلك للحصول على أكبر قدر من المعلومات.

I Pilotare diversi prodotti DALI tramite pulsante (es: Touch-dim, Switch-dim, Push-dim, Direct-dim, etc.) potrebbe causare dei problemi di sincronizzazione tra gli stessi. È possibile ovviare a questo problema dotandosi di dispositivi aggiuntivi. Per maggiori informazioni vi invitiamo a contattarci direttamente.

GB Controlling different DALI products through buttons (e.g.: Touch-dim, Switch-dim, Push-dim, Direct-dim, etc.) may lead to product synchronisation problems. This problem can be overcome by using additional devices. For further information, please contact us directly.

E El mando de varios productos DALI por tecla (ej: Touch-dim, Switch-dim, Push-dim, Direct-dim, etc.) podría causar problemas de sincronización entre ellos. Es posible prevenir este problema utilizando dispositivos adicionales. Para más información, contacte directamente con nosotros.

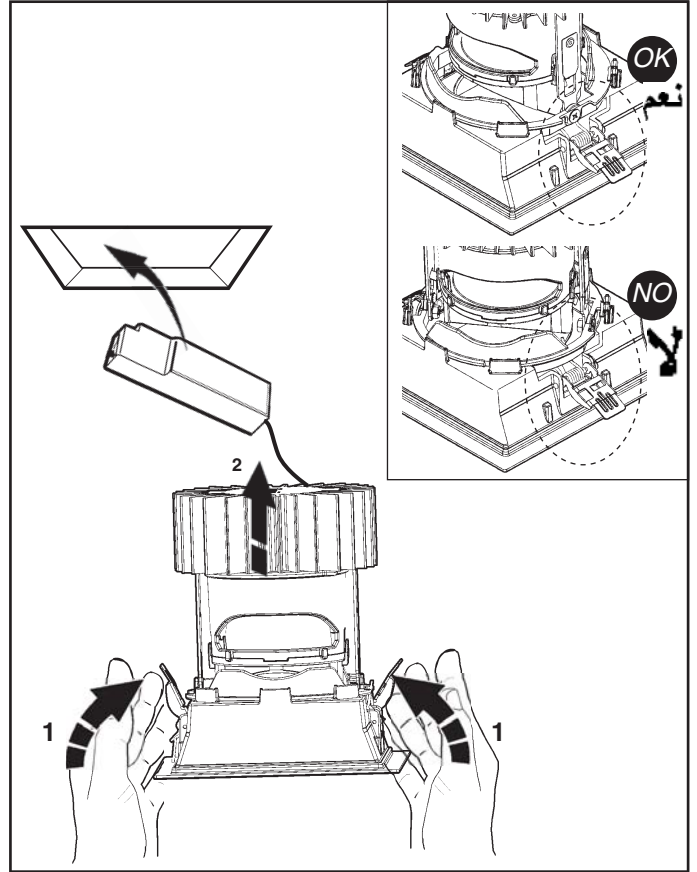

تركيب الملحقات

INSTALLAZIONE DEGLI ACCESSORI
INSTALLING THE ACCESSORIES
INSTALACION DE ACCESORIOS

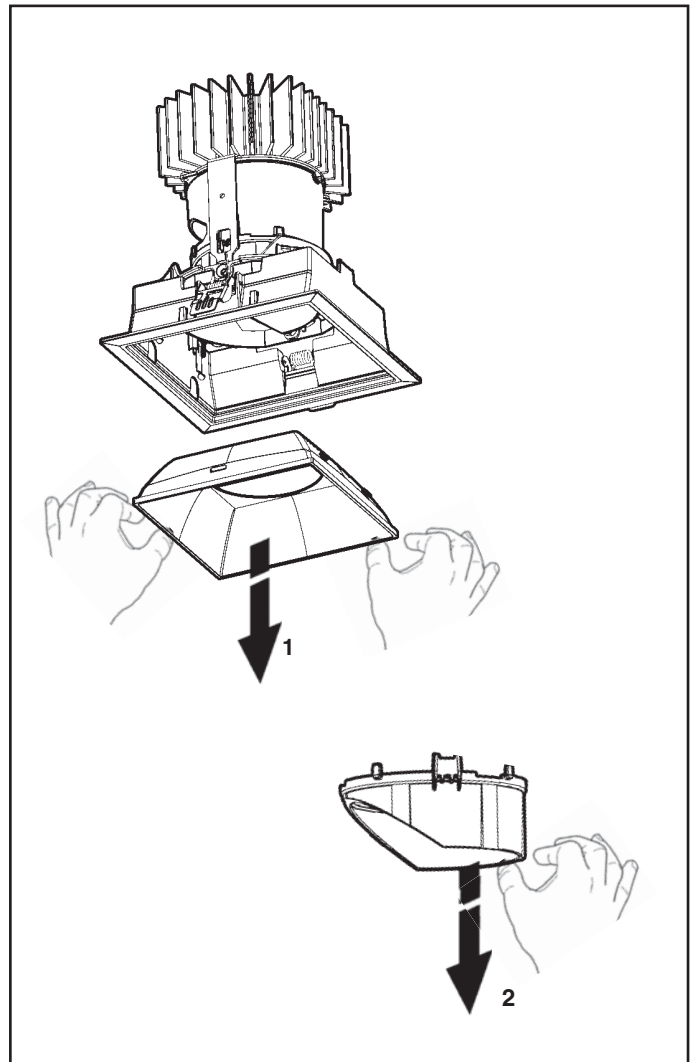

	شحنة DALI / حمل DALI CARICO DALI / DALI LOAD CHARGE DALI CARGA DALI	عناوين DALI INDIRIZZI DALI DALI ADDRESSES DIRECCIONES DALI
الصفحة ART.	2mA	1

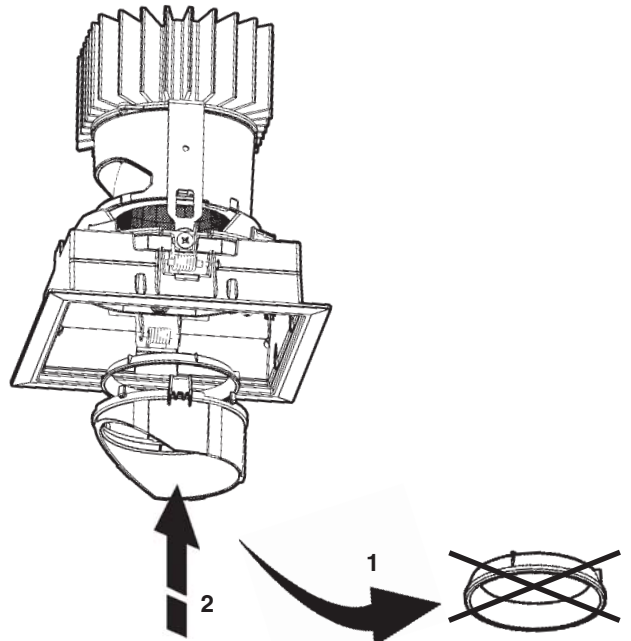
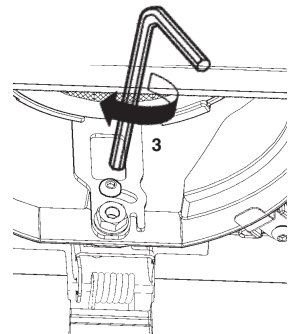
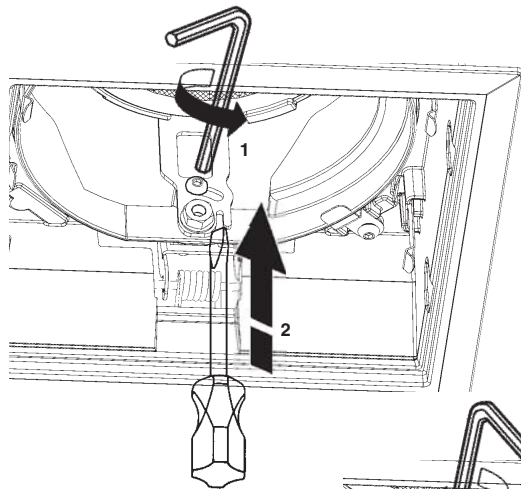
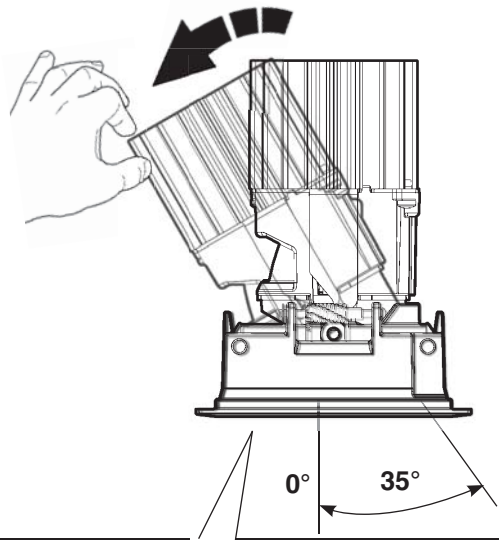
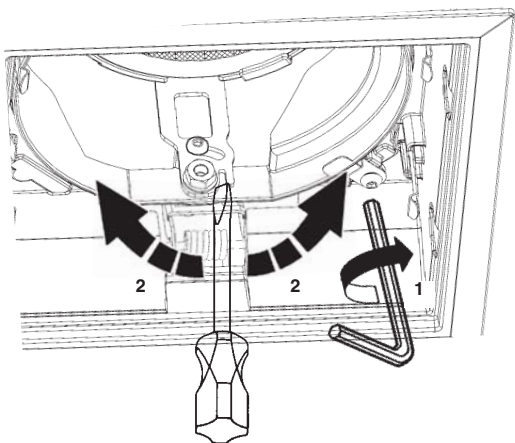
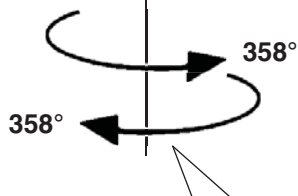
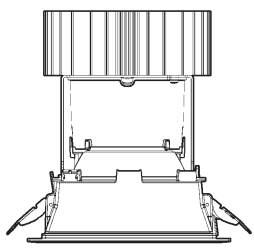
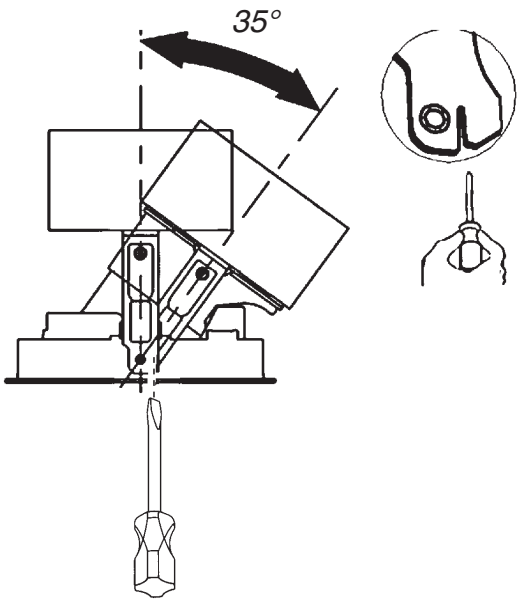

+ art. MXV1

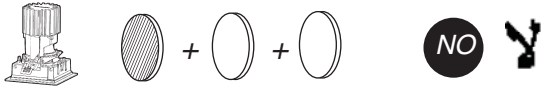
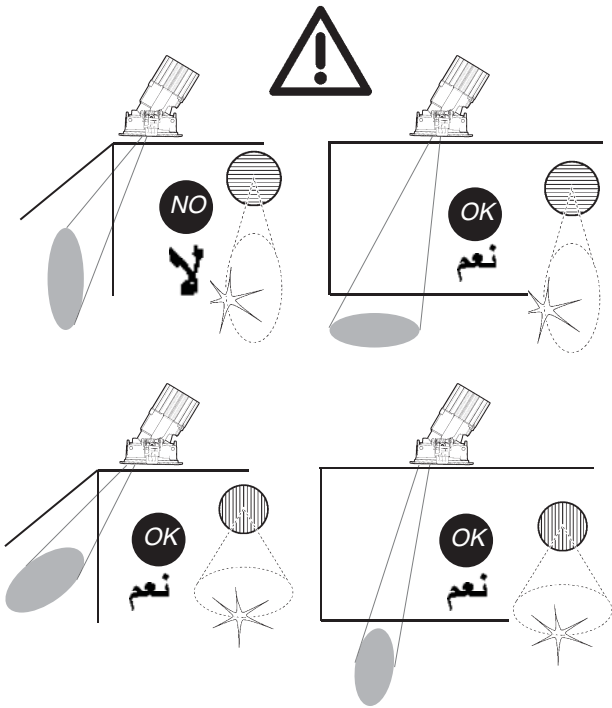
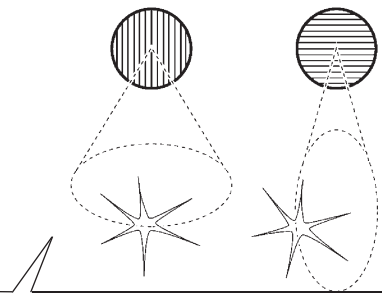
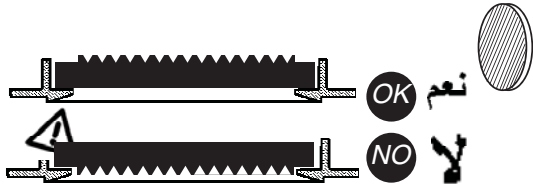

+ art. MY47 - MY48 - MY49

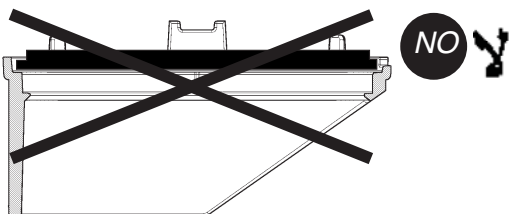
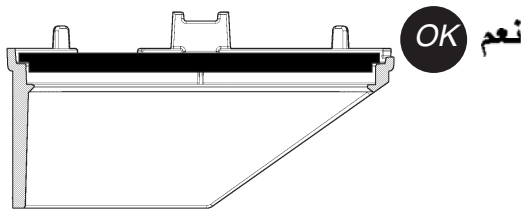

+ art. MY38

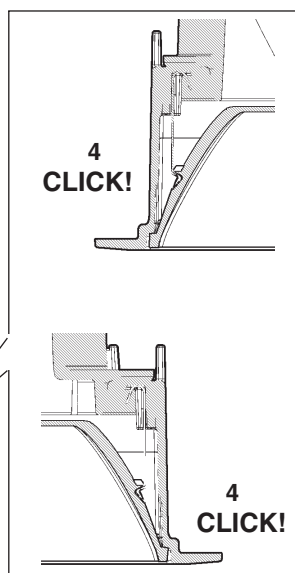
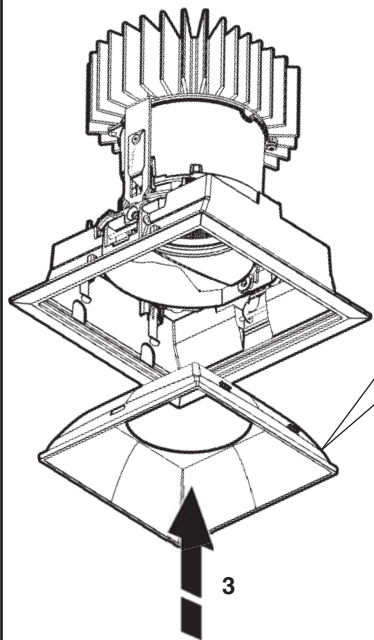
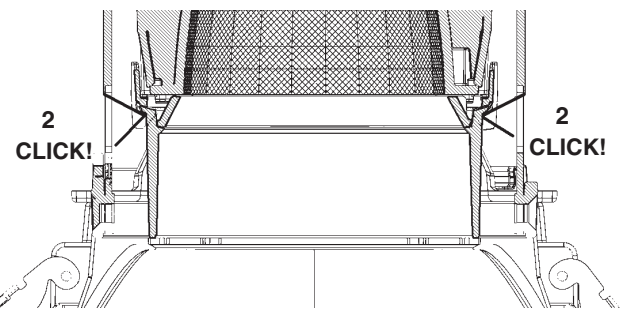
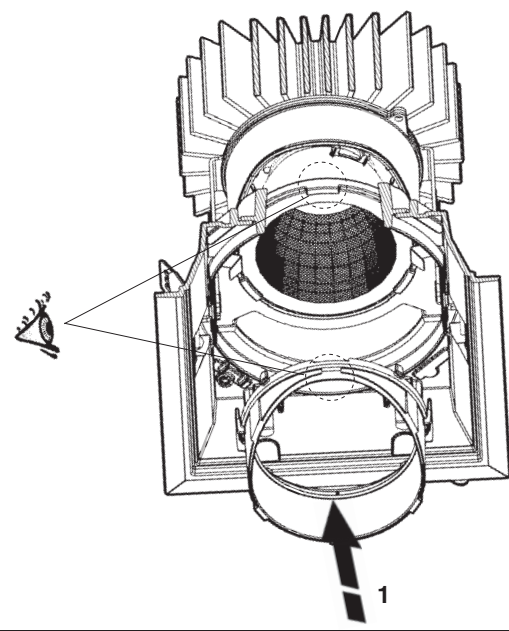
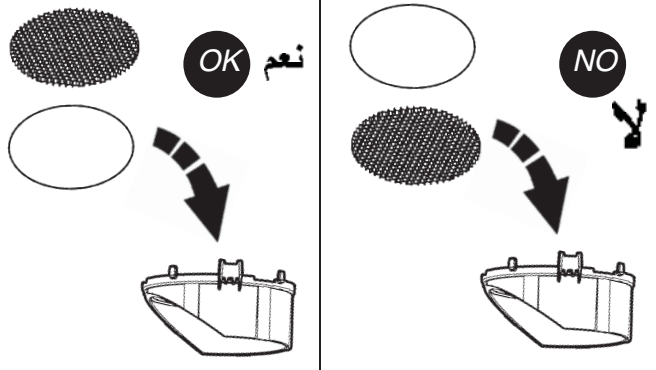

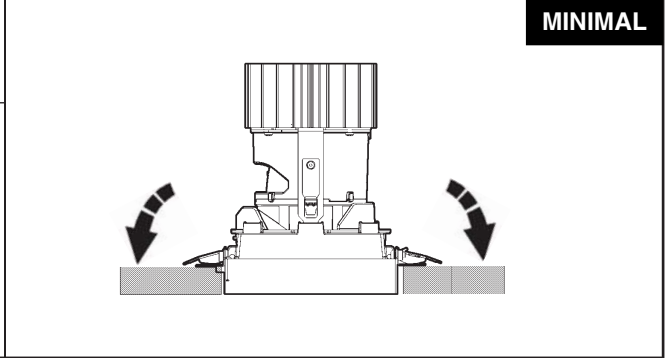
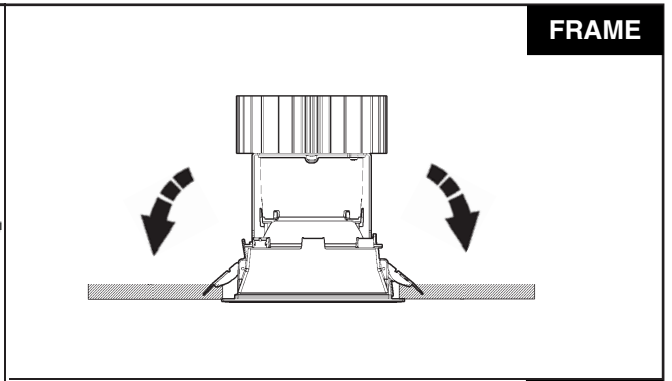
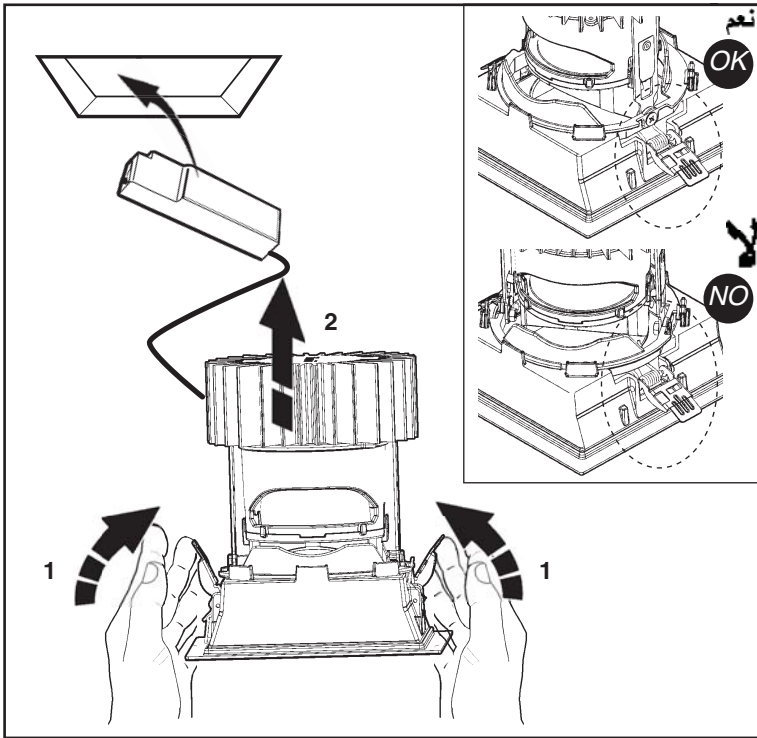

الصنف ART.	art. MY38	art. MXV1	art. 4491	art. MY46	art. MY50			art. MY47	art. MY48	art. MY49
					.05	.06	.16			
P758	✓	✓	✓	✓	✗	✓	✗	✗	✗	✗
P759	✓	✓	✓	✓	✓	✓	✓	✓	✓	✓
P760	✓	✓	✓	✓	✗	✓	✗	✗	✗	✗
P761	✓	✓	✓	✓	✗	✓	✗	✗	✗	✗
P762	✓	✓	✓	✓	✗	✓	✗	✗	✗	✗
P763	✓	✓	✓	✓	✓	✓	✓	✓	✓	✓
P764	✓	✓	✓	✓	✗	✓	✗	✗	✗	✗
P765	✓	✓	✓	✓	✗	✓	✗	✗	✗	✗
P766	✓	✓	✓	✓	✗	✓	✗	✗	✗	✗
P767	✓	✓	✓	✓	✗	✓	✗	✗	✗	✗
P768	✓	✓	✓	✓	✓	✓	✓	✓	✓	✓
P769	✓	✓	✓	✓	✗	✓	✗	✗	✗	✗
P770	✓	✓	✓	✓	✗	✓	✗	✗	✗	✗
P771	✓	✓	✓	✓	✗	✓	✗	✗	✗	✗
P772	✓	✓	✓	✓	✓	✓	✓	✓	✓	✓
P773	✓	✓	✓	✓	✗	✓	✗	✗	✗	✗
P774	✓	✓	✓	✓	✗	✓	✗	✗	✗	✗
P775	✓	✓	✓	✓	✗	✓	✗	✗	✗	✗

استبدال الضوء LED

SOSTITUZIONE DEL LED
REPLACING THE LED
REEMPLAZO DEL LED

تنبيه: لاستبدال الضوء LED اتصل بشركة iGuzzini . عر

I N.B.: Per la sostituzione del LED contattare l'azienda iGuzzini.

GB N.B.: For information on LED replacement please contact iGuzzini.

E NOTA: Para sustituir el LED llame a la empresa iGuzzini.



لا يمكن استعمال المنتج في حالة كسر الزجاج، وبالتالي يجب الاتصال بالمتابع لاستبداله. عر

I In caso di rottura del vetro il prodotto non può essere utilizzato, contattare il costruttore per la sua sostituzione.

GB Should the glass break, the product cannot be used and you should contact the manufacturer for its replacement.

E No utilizar el producto en caso de ruptura del vidrio y contactar el fabricante para la sustitución.

ONLY FOR DALI PRODUCT

1.154.599.01
IS03599/03

iGuzzini

- I** **ATTENZIONE:** con questo errore di collegamento il prodotto rischia di bloccarsi (FIG. 1).
Per ripristinare, premere il pulsante 5 volte in 3 secondi come in FIG. 2, dopo che il difetto è stato rimosso.
- GB** **WARNING:** with this connection error the product risks to get blocked (FIG. 1).
To restore, press the button 5 times in 3 seconds as shown in FIG. 2 after removing the defect.
- F** **ATTENTION :** cette erreur de raccordement risque de bloquer le produit (FIG. 1).
Pour rétablir son fonctionnement, appuyer sur le bouton 5 fois de suite pendant 3 secondes comme illustré FIG. 2, après avoir supprimé le défaut.
- D** **ACHTUNG:** Bei diesem Anschlussfehler kann sich das Produkt blockieren (ABB. 1).
Zum Zurücksetzen drücken Sie die Taste 5 Mal innerhalb von 3 Sekunden wie in ABB. 2 gezeigt, nachdem der Fehler behoben wurde.
- NL** **OPGELET:** met deze aansluitingsstoring riskeert u dat het product blokkeert. (AFB. 1).
Om dit te herstellen moet u 5 keer in 3 seconden op de toets drukken, zoals aangegeven in AFB. 2, nadat de storing is opgelost.
- E** **ATENCIÓN:** con este error de conexión existe un riesgo de bloqueo del producto (FIG. 1).
Para restablecer, oprimir el pulsador 5 veces en 3 segundos según ilustrado en la FIG. 2, después de eliminar el defecto.
- N** **ADVASEL:** med denne koblingsfeilen risikerer produktet å blokkeres (FIG. 1).
For å gjenopprette, trykk på knappen 5 ganger i løpet av 3 sekunder, som angitt i FIG. 2, etter at feilen er fjernet.
PAS PÅ: Ved den type feil i forbindelsen kan man risikere, at produktet låses fast (FIG. 1).
- DK** For at genoprette funktionen skal man trykke knappen ind 5 gange i 3 sekunder, som vist i FIG. 2, efter at fejlen er blevet udbedret.
- S** **OBSERVERA!** Med detta fel finns det risk för att produkten blockeras (FIG. 1).
För att återställa efter att defekten har åtgärdats, tryck ned knappen 5 gånger i 3 sekunder som i FIG. 2.
- RUS** **ВНИМАНИЕ:** при наличии этой ошибки соединения продукт может заблокироваться (PVC. 1).
Для восстановления нажмите на кнопку 5 раз за 3 секунды, как указано на PVC. 2, после того как был устранен дефект.
- CN** 注意：出现这种故障时，灯具可能停止运行（1号图表）。
要重新启动，排除故障之后，请按照2号图表按按钮五次，每次三秒钟。

FIG. 1
FIG. 1
FIG. 1
ABB. 1
AFB. 1
FIG. 1
FIG. 1
FIG. 1
FIG. 1
1号图表

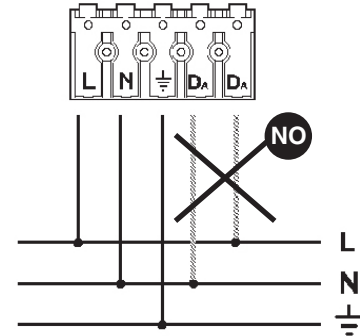

NO
NO
NON
NEIN
NEE
NO
NEI
NEJ
NEJ
HET
禁止

FIG. 2
FIG. 2
ABB. 2
AFB. 2
FIG. 2
FIG. 2
FIG. 2
2号图表

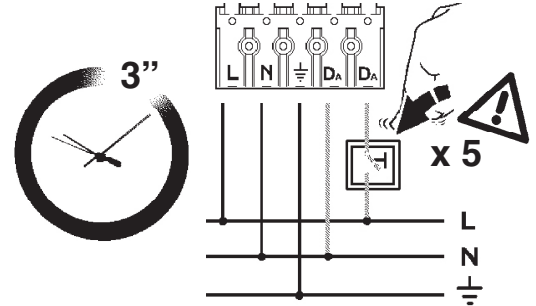

L
N
PE
禁止

ONLY FOR DALI PRODUCT

1.154.599.01
IS03599/03

iGuzzini

- I** **ATTENZIONE:** con questo errore di collegamento il prodotto rischia di bloccarsi (FIG. 1).
Per ripristinare, premere il pulsante 5 volte in 3 secondi come in FIG. 2, dopo che il difetto è stato rimosso.
- GB** **WARNING:** with this connection error the product risks to get blocked (FIG. 1).
To restore, press the button 5 times in 3 seconds as shown in FIG. 2 after removing the defect.
- F** **ATTENTION :** cette erreur de raccordement risque de bloquer le produit (FIG. 1).
Pour rétablir son fonctionnement, appuyer sur le bouton 5 fois de suite pendant 3 secondes comme illustré FIG. 2, après avoir supprimé le défaut.
- D** **ACHTUNG:** Bei diesem Anschlussfehler kann sich das Produkt blockieren (ABB. 1).
Zum Zurücksetzen drücken Sie die Taste 5 Mal innerhalb von 3 Sekunden wie in ABB. 2 gezeigt, nachdem der Fehler behoben wurde.
- NL** **OPGELET:** met deze aansluitingsstoring riskeert u dat het product blokkeert. (AFB. 1).
Om dit te herstellen moet u 5 keer in 3 seconden op de toets drukken, zoals aangegeven in AFB. 2, nadat de storing is opgelost.
- E** **ATENCIÓN:** con este error de conexión existe un riesgo de bloqueo del producto (FIG. 1).
Para restablecer, oprimir el pulsador 5 veces en 3 segundos según ilustrado en la FIG. 2, después de eliminar el defecto.
- N** **ADVASEL:** med denne koblingsfeilen risikerer produktet å blokkeres (FIG. 1).
For å gjenopprette, trykk på knappen 5 ganger i løpet av 3 sekunder, som angitt i FIG. 2, etter at feilen er fjernet.
PAS PÅ: Ved den type feil i forbindelsen kan man risikere, at produktet låses fast (FIG. 1).
- DK** For at genoprette funktionen skal man trykke knappen ind 5 gange i 3 sekunder, som vist i FIG. 2, efter at fejlen er blevet udbedret.
- S** **OBSERVERA!** Med detta fel finns det risk för att produkten blockeras (FIG. 1).
För att återställa efter att defekten har åtgärdats, tryck ned knappen 5 gånger i 3 sekunder som i FIG. 2.
- RUS** **ВНИМАНИЕ:** при наличии этой ошибки соединения продукт может заблокироваться (PVC. 1).
Для восстановления нажмите на кнопку 5 раз за 3 секунды, как указано на PVC. 2, после того как был устранен дефект.
- CN** 注意：出现这种故障时，灯具可能停止运行（1号图表）。
要重新启动，排除故障之后，请按照2号图表按按钮五次，每次三秒钟。

FIG. 1
FIG. 1
FIG. 1
ABB. 1
AFB. 1
FIG. 1
FIG. 1
FIG. 1
FIG. 1
1号图表

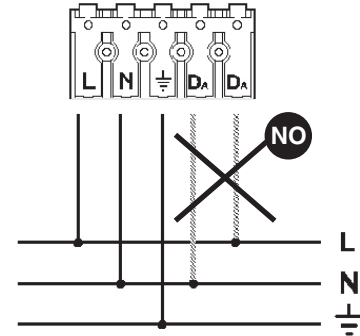

NO
NO
NON
NEIN
NEE
NO
NEI
NEJ
NEJ
HET
禁止

FIG. 2
FIG. 2
ABB. 2
AFB. 2
FIG. 2
FIG. 2
FIG. 2
2号图表

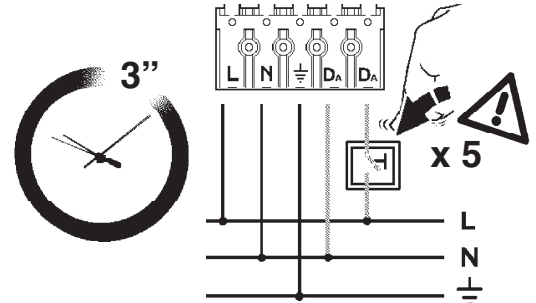

L
N
PE
禁止

ONLY FOR DALI PRODUCT

1.154.599.01
IS03599/03

iGuzzini

- I** **ATTENZIONE:** con questo errore di collegamento il prodotto rischia di bloccarsi (FIG. 1).
Per ripristinare, premere il pulsante 5 volte in 3 secondi come in FIG. 2, dopo che il difetto è stato rimosso.
- GB** **WARNING:** with this connection error the product risks to get blocked (FIG. 1).
To restore, press the button 5 times in 3 seconds as shown in FIG. 2 after removing the defect.
- F** **ATTENTION :** cette erreur de raccordement risque de bloquer le produit (FIG. 1).
Pour rétablir son fonctionnement, appuyer sur le bouton 5 fois de suite pendant 3 secondes comme illustré FIG. 2, après avoir supprimé le défaut.
- D** **ACHTUNG:** Bei diesem Anschlussfehler kann sich das Produkt blockieren (ABB. 1).
Zum Zurücksetzen drücken Sie die Taste 5 Mal innerhalb von 3 Sekunden wie in ABB. 2 gezeigt, nachdem der Fehler behoben wurde.
- NL** **OPGELET:** met deze aansluitingsstoring riskeert u dat het product blokkeert. (AFB. 1).
Om dit te herstellen moet u 5 keer in 3 seconden op de toets drukken, zoals aangegeven in AFB. 2, nadat de storing is opgelost.
- E** **ATENCIÓN:** con este error de conexión existe un riesgo de bloqueo del producto (FIG. 1).
Para restablecer, oprimir el pulsador 5 veces en 3 segundos según ilustrado en la FIG. 2, después de eliminar el defecto.
- N** **ADVASEL:** med denne koblingsfeilen risikerer produktet å blokkeres (FIG. 1).
For å gjenopprette, trykk på knappen 5 ganger i løpet av 3 sekunder, som angitt i FIG. 2, etter at feilen er fjernet.
PAS PÅ: Ved den type feil i forbindelsen kan man risikere, at produktet låses fast (FIG. 1).
- DK** For at genoprette funktionen skal man trykke knappen ind 5 gange i 3 sekunder, som vist i FIG. 2, efter at fejlen er blevet udbedret.
- S** **OBSERVERA!** Med detta fel finns det risk för att produkten blockeras (FIG. 1).
För att återställa efter att defekten har åtgärdats, tryck ned knappen 5 gånger i 3 sekunder som i FIG. 2.
- RUS** **ВНИМАНИЕ:** при наличии этой ошибки соединения продукт может заблокироваться (PVC. 1).
Для восстановления нажмите на кнопку 5 раз за 3 секунды, как указано на PVC. 2, после того как был устранен дефект.
- CN** 注意：出现这种故障时，灯具可能停止运行（1号图表）。
要重新启动，排除故障之后，请按照2号图表按按钮五次，每次三秒钟。

FIG. 1
FIG. 1
FIG. 1
ABB. 1
AFB. 1
FIG. 1
FIG. 1
FIG. 1
FIG. 1
1号图表

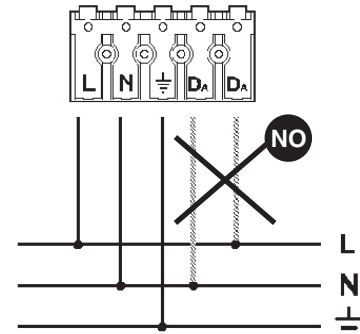

NO
NO
NON
NEIN
NEE
NO
NEI
NEJ
NEJ
HET
禁止

FIG. 2
FIG. 2
ABB. 2
AFB. 2
FIG. 2
FIG. 2
FIG. 2
2号图表

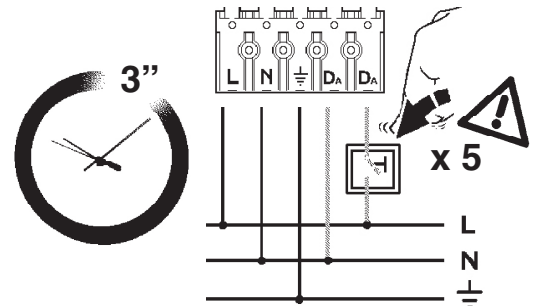

L
N
PE
禁止

ONLY FOR DALI PRODUCT

2.509.296.01
IS07392/01

iGuzzini

الشكل 1
FIG. 1



تنبيه: خطر حدوث عطل مع هذا الخطأ في التوصيل. (الشكل 1)
لإعادة التنشيط، اضغط على الزر 5 مرات في 3 ثوان كما هو موضح في الشكل 2، بعد التأكد من تلاشي الخطأ.

- I **ATTENZIONE:** con questo errore di collegamento il prodotto rischia di bloccarsi (FIG. 1).
Per ripristinare, premere il pulsante 5 volte in 3 secondi come in FIG. 2, dopo che il difetto è stato rimosso.
- GB **WARNING:** with this connection error the product risks to get blocked (FIG. 1).
To restore, press the button 5 times in 3 seconds as shown in FIG. 2 after removing the defect.
- E **ATENCIÓN:** con este error de conexión existe un riesgo de bloqueo del producto (FIG. 1).
Para restablecer, oprimir el pulsador 5 veces en 3 segundos según ilustrado en la FIG. 2, después de eliminar el defecto.

الشكل 2
FIG. 2

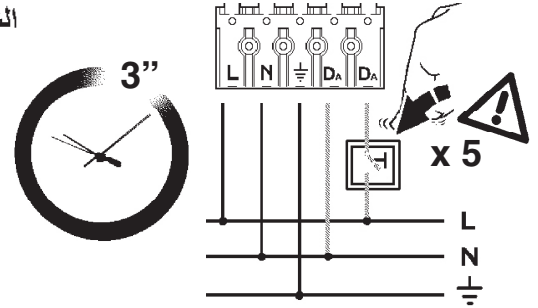

ONLY FOR DALI PRODUCT

2.509.296.01
IS07392/01

iGuzzini

الشكل 1
FIG. 1

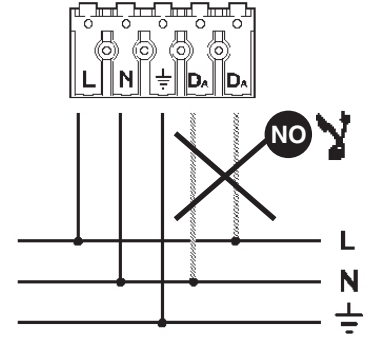

تنبيه: خطر حدوث عطل مع هذا الخطأ في التوصيل. (الشكل 1)
لإعادة التنشيط، اضغط على الزر 5 مرات في 3 ثوان كما هو موضح في الشكل 2، بعد التأكد من تلاشي الخطأ.

- I **ATTENZIONE:** con questo errore di collegamento il prodotto rischia di bloccarsi (FIG. 1).
Per ripristinare, premere il pulsante 5 volte in 3 secondi come in FIG. 2, dopo che il difetto è stato rimosso.
- GB **WARNING:** with this connection error the product risks to get blocked (FIG. 1).
To restore, press the button 5 times in 3 seconds as shown in FIG. 2 after removing the defect.
- E **ATENCIÓN:** con este error de conexión existe un riesgo de bloqueo del producto (FIG. 1).
Para restablecer, oprimir el pulsador 5 veces en 3 segundos según ilustrado en la FIG. 2, después de eliminar el defecto.

الشكل 2
FIG. 2

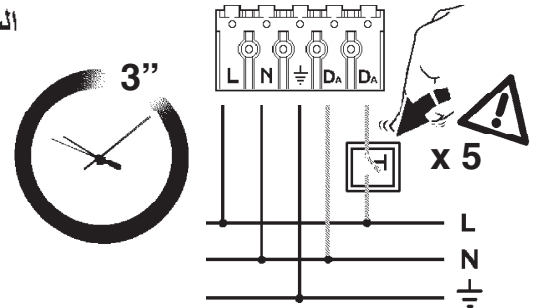

ONLY FOR DALI PRODUCT

2.509.296.01
IS07392/01

iGuzzini

الشكل 1
FIG. 1

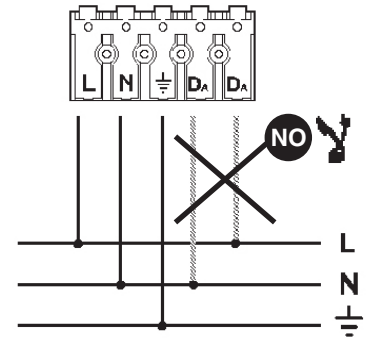

تنبيه: خطر حدوث عطل مع هذا الخطأ في التوصيل. (الشكل 1)
لإعادة التنشيط، اضغط على الزر 5 مرات في 3 ثوان كما هو موضح في الشكل 2، بعد التأكد من تلاشي الخطأ.

- I **ATTENZIONE:** con questo errore di collegamento il prodotto rischia di bloccarsi (FIG. 1).
Per ripristinare, premere il pulsante 5 volte in 3 secondi come in FIG. 2, dopo che il difetto è stato rimosso.
- GB **WARNING:** with this connection error the product risks to get blocked (FIG. 1).
To restore, press the button 5 times in 3 seconds as shown in FIG. 2 after removing the defect.
- E **ATENCIÓN:** con este error de conexión existe un riesgo de bloqueo del producto (FIG. 1).
Para restablecer, oprimir el pulsador 5 veces en 3 segundos según ilustrado en la FIG. 2, después de eliminar el defecto.

الشكل 2
FIG. 2

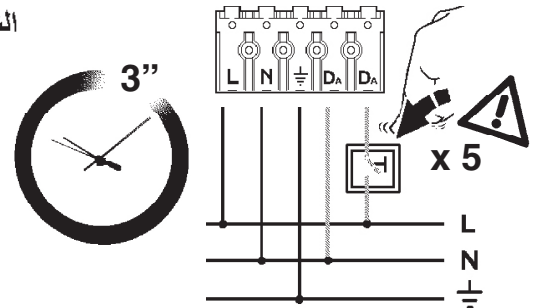

- I Istruzioni per le operazioni di servizio per l'apparecchio di illuminazione**
GB Instructions on luminaire service operations
F Instructions pour les opérations de service du luminaire
D Wartungsanleitung für die Leuchte
NL Instructies voor de onderhoudsoperaties op de verlichtingsarmatuur
E Instrucciones para las operaciones de servicio del aparato de alumbrado
DK Anvisninger i serviceindgreb på belysningsarmatur
N Anvisninger for betjening av lysapparatet
S Instruktioner för användning av belysningsanordningen
RUS Инструкции по эксплуатации осветительного прибора
CN 照明装置检修操作说明

Sostituire la lampada parzialmente esausta
 Replace the partly exhausted lamp
 Remplacer la lampe partiellement épuisée
 Die teilweise erschöpfte Lampe austauschen
 Vervang de gedeeltelijk lege lamp
 Sustituir la lámpara parzialmente agotada
 Udskift den delvist udtjente pære
 Skifte ut den delvis utbrente lyspæren
 Byt ut den delvis förbrukade lampan
 Замена частично отработавшей лампочки
 更换部分老化的灯泡



Spegnimento
 Switch it off
 Extinction
 Ausschaltung
 Uitschakeling
 Apagado
 Slukning
 Slukking
 Släckning
 Выключение
 关灯

Interrompere l'alimentazione dell'apparecchio
 Cut the power supply to the luminaire
 Couper l'alimentation du luminaire
 Stromversorgung der Leuchte unterbrechen
 Onderbreek de voeding van het apparaat
 Interrumpir la alimentación del aparato
 Afbryd armaturets strømforsyning
 Avbryte strømtilførselen til apparatet
 Koppla från anordningens strömförsörjning
 Отключить электропитание прибора
 中断装置供电



Aprire l'apparecchio
 Open the fixture
 Ouvrir le luminaire
 Das Gerät öffnen
 Open het apparaat
 Abrir el aparato
 Åbn armaturet
 Åpne apparatet
 Öppna anordningen
 Раскрыть прибор
 打开装置



Rimuovere la lampada esausta
 Remove the exhausted lamp
 Retirer la lampe épuisée
 Die alte Lampe entnehmen
 Verwijder de lege lamp
 Quitar la lámpara agotada
 Tag den udtjente pære ud
 Fjerne den utbrente lyspæren
 Ta bort den förbrukade lampan
 Вынуть старую лампочку
 取出老化的灯泡

Portarla in un centro di riciclaggio
 Carry it to a recycling centre
 La porter dans une déchetterie pour son recyclage
 Ordnungsgemäß entsorgen
 Breng de lamp naar een recyclingcentrum
 Llevarla a un centro de reciclaje
 Aflever den på en genbrugsstation
 Lever den til en miljøstasjon
 Lämna in den till en återvinningsanläggning
 Сдать ее в пункт приема утильсырья
 将其送往回收中心

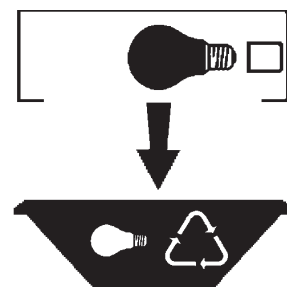

Inserire la nuova lampada
 Introduce the new lamp
 Installer la lampe neuve
 Die neue Lampe einsetzen
 Doe de nieuwe lamp op zijn plek
 Montar la nueva lámpara
 Sæt den nye pære i
 Sette i den nye pæren
 Sätt i den nya lampan
 Вставить новую лампочку
 装入新灯泡

Inserire la nuova lampada nel portalampana
 Fit the new lamp into the socket
 Installer la nouvelle lampe dans le support de lampe
 Die neue Lampe in den Sockel einsetzen
 Doe de nieuwe lamp in de lamphouder
 Montar la nueva lámpara en el portalampana
 Sæt den nye pære i fatningen
 Sette den nye pæren inn i lampeholderen
 Sätt i den nya lampan i lamphållaren
 Вставить новую лампочку в патрон
 将新灯泡插入灯泡架中



Riposizionare ottica
 Re-place the optic
 Remettre l'optique à sa place
 Die Optik wieder einsetzen
 Doe de optiek weer op zijn plaats
 Volver a montar la óptica
 Sæt den optiske enhed på plads
 Innstille linsen
 Flytta om optiken
 Отрегулировать линзы
 重新定位光头



Effettuare prova di funzionamento
 Perform operative test
 Procéder à un essai de fonctionnement
 Eine Funktionsprüfung durchführen
 Controleer de correcte werking
 Hacer una prueba de funcionamiento
 Afprøv funktionen
 Prøve om den fungerer
 Utför funktionstest
 Выполнить проверку исправности работы
 执行功能测试



I Istruzioni per la pulizia dell'apparecchio di illuminazione
 GB Instructions on luminaire cleaning operations
 F Instructions pour le nettoyage du luminaire
 D Anweisungen zur Reinigung der Leuchte
 NL Instructies voor de reiniging van de verlichtingsarmatuur
 E Instrucciones para limpiar el aparato de alumbrado
 DK Anvisninger i rengøring af belysningsarmaturet
 N Anvisninger for rengjøring av lysapparatet
 S Instruktioner för rengöring av belysningsanordningen
 RUS Инструкции по чистке осветительного прибора
 CN 照明装置清洁说明

Pulire l'apparecchio
 Clean the fixture
 Nettoyer le luminaire
 Das Gerät reinigen
 Reinig het apparaat
 Limpiar el aparato
 Rengør armaturet
 Rengjøre apparatet
 Rengör anordningen
 Чистка прибора
 清洁装置



Spegnimento
 Switch it off
 Extinction
 Ausschaltung
 Uitschakeling
 Apagado
 Slukning
 Slukking
 Släckning
 Выключение
 关灯

Interrompere l'alimentazione dell'apparecchio
 Cut the power supply to the luminaire
 Couper l'alimentation du luminaire
 Stromversorgung der Leuchte unterbrechen
 Onderbreek de voeding van het apparaat
 Interrumpir la alimentación del aparato
 Afbryd armaturets strømforsyning
 Avbryt strømtilførselen til apparatet
 Koppla från anordningens strömförsörjning
 Отключить электропитание прибора
 中断装置供电

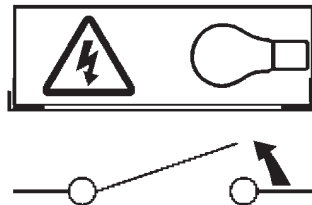

Spolverare l'ottica esterna
 Remove dust from the external optic
 Dépoussiérer l'optique extérieure
 Die externe Optik abstauben
 Stof de externe optiek af
 Quitar el polvo de la óptica exterior
 Tør støvet af den udvendige optiske enhed
 Fjerne støv fra den eksterne lysenheden
 Damma av den yttre optiken
 Вытереть пыль с внешней стороны линз
 为外侧光头掸尘

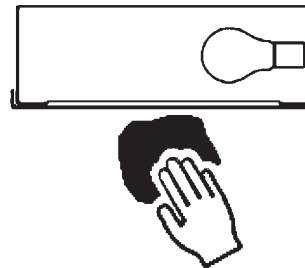

Lavare l'ottica esterna
 Wash the external optic
 Laver l'optique extérieure
 Die externe Optik waschen
 Was de externe optiek
 Lavar la óptica exterior
 Vask den udvendige optiske enhed
 Vaske den eksterne lysenheden
 Rengör den yttre optiken
 Вымыть линзы с внешней стороны
 清洁外光头

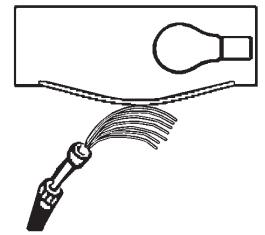

Rimuovere l'ottica
 Remove the optic
 Retirer l'optique
 Die Optik abnehmen
 Verwijder de optiek
 Quitar la óptica
 Tag den optiske enhed af
 Fjerne lysenheden
 Ta bort optiken
 Снять линзы
 取下光头

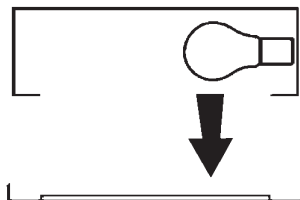

Pulire la parte interna dell'apparecchio di illuminazione
 Clean the inside of the fixture
 Nettoyer l'intérieur du luminaire
 Die Innenseite der Leuchte reinigen
 Reinig de binnenzijde van de verlichtingsarmatuur
 Limpiar el interior del aparato de alumbrado
 Rengør belysningsarmaturets indvendige dele
 Rengjøre lysapparatet innvendig
 Rengör belysningsanordningen invändigt
 Протереть осветительный прибор изнутри
 清洁照明装置内部



Riposizionare ottica
 Re-place the optic
 Remettre l'optique à sa place
 Die Optik wieder einsetzen
 Doe de optiek weer op zijn plaats
 Volver a montar la óptica
 Sæt den optiske enhed på plads
 Innstille linsen
 Flytta om optiken
 Отрегулировать линзы
 重新定位光头

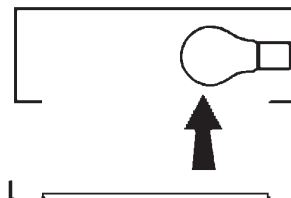

Effettuare prova di funzionamento
 Perform operative test
 Procéder à un essai de fonctionnement
 Eine Funktionsprüfung durchführen
 Controleer de correcte werking
 Hacer una prueba de funcionamiento
 Afprøv funktionen
 Prøve om den fungerer
 Utför funktionstest
 Выполнить проверку исправности работы
 执行功能测试

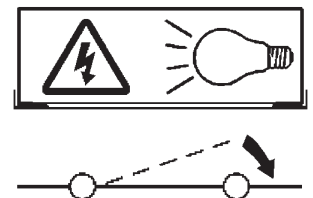

- I** Istruzioni per il fine vita e lo smaltimento dei componenti
GB Instructions on end-of-life and component disposal
F Instructions pour la gestion des composants en fin de vie et leur mise au rebut
D Anweisungen zur Entsorgung der Leuchtenkomponenten
NL Instructies voor het verwijderen van de armatuur en het recyclen van de onderdelen
E Instrucciones para el final de vida y la eliminación los componentes
DK Anvisninger i udtjent armatur og bortskaffelse af komponenter
N Anvisninger for endt levetid og avfallsbehandling av delene
S Instruktioner vid bortskaffning och kassering av komponenter
RUS Инструкции по утилизации прибора и его комплектующих по окончании его срока службы
CN 寿命期结束与零件废弃处置说明

<p>Spegnimento Switch it off Extinction Ausschaltung Uitschakeling Apagado Slukning Slukking Släckning Выключение 关灯</p> <p>Interrompere l'alimentazione dell'apparecchio Cut the power supply to the luminaire Couper l'alimentation du luminaire Stromversorgung der Leuchte unterbrechen Onderbreek de voeding van het apparaat Interrompirla alimentación del aparato Afbryd armaturets strømforsyning Avbryt strømtilførselen til apparatet Koppla från anordningens strömförsörjning Отключить электропитание прибора 中断装置供电</p> 	<p>Rimuovere la/e lampada/e per la dismissione Remove the lamp(s) for decommissioning Retirer la(les) lampe(s) pour sa(leur) mise au rebut Die Lampe/n ordnungsgemäß entsorgen Verwijder de lamp(en) voor het recyclen Quitar la(s) lámpara(s) para el desecho Tag pæren/pærerne ud til bortskaffelse Fjerne lampen/-e som skal kastes Ta bort lampan/-orna för bortskaffningen Вынуть лампочку/и для утилизации прибора 取出需要丢弃的灯泡</p> 	<p>Rimuovere la batteria per la dismissione Remove the battery for decommissioning Retirer la batterie pour sa mise au rebut Die Batterie ordnungsgemäß entsorgen Verwijder de batterij voor het recyclen Quitar la batería para el desecho Tag batteriet ud til bortskaffelse Fjerne batteriet som skal kastes Ta bort batteriet för bortskaffningen Вынуть батарейку для утилизации прибора 取出需要丢弃的电池</p> 	<p>Rimuovere l'apparecchio per la dismissione Remove the fixture for decommissioning Enlever le luminaire pour sa mise au rebut Das Gerät ordnungsgemäß entsorgen Verwijder het apparaat voor het recyclen Quitar el aparato para el desecho Tag armaturet ud til bortskaffelse Fjerne apparatet som skal kastes Ta bort anordningen för bortskaffningen Снять прибор для утилизации 取出需要丢弃的装置</p> 
---	--	--	--

<p>Inviare i materiali ad un centro di raccolta RAEE Send the materials to a WEEE collection centre Envoyer les matériaux dans une déchetterie DEEE Die Materialien in einem WEEE-Zentrum entsorgen Zend de materialen naar een recyclingscentrum voor de AEEA Enviar los materiales a un centro de recogida RAEE Afløver materialerne på et indsamlingscenter for elektronisk udstyr Sende materialene til en miljøstasjon for resirkulering av EE-avfall Skicka materialet till en RAEE uppsamlingscentral Сдать материалы в пункт приема утильсырья 将材料送往电气和电子垃圾回收中心</p> 			
--	--	--	--