

1.154.933.02 IS09948/02	iGuzzini	TENSIONE DI ALIMENTAZIONE POWER SUPPLY VOLTAGE TENSION D'ALIMENTATION VERSORGUNGSSPANNUNG VOEDINGSSPANNING TENSÓN DE ALIMENTACIÓN FORSYNINGSSPÆNDING SPENNING STRØMTILFØRSEL MATNINGSSPÄNNING напряжение электропитания 主电压	corrente assorbita absorbed current courant absorbé Stromaufnahme stroomopname corriente absorbida absorberet strøm absorbert strøm tillförd ström поглощаемая мощность 电源电流
ART.		(V)	(A)
P315-P316-P317-P318-P319-P320-P321-P322-P323-P324 P325-P326-P327-P328-P363-P364-P365-P366-P367-P368 P329-P330-P331-P332-P333-P334-P335-P336-P337-P338 P339-P340-P378-P379-P380-P381-P382-P383		31,9	0,25
P341-P342-P343-P344-P345-P348-P349-P350 P351-P354-P355-P356-P357-P358-P359-P369-P370-P384 P385-P372-P373-P374-P375-P387-P388-P389-P390-P391 P392-P393-P394-P395-P396-P397-P398-Q806-Q807-Q809 Q810-Q812-Q813-Q815-Q816-Q817-Q818		35,8	0,3
P346-P347-P352-P353-P360-P361-P362-P371-P376-P377-P386 Q808-Q811-Q814		36,5 Vdc 2700°K 27,3 Vdc 1800°K	0,3 0,006

1.154.933.02 IS09948/02	iGuzzini	TENSIONE DI ALIMENTAZIONE POWER SUPPLY VOLTAGE TENSION D'ALIMENTATION VERSORGUNGSSPANNUNG VOEDINGSSPANNING TENSÓN DE ALIMENTACIÓN FORSYNINGSSPÆNDING SPENNING STRØMTILFØRSEL MATNINGSSPÄNNING напряжение электропитания 主电压	corrente assorbita absorbed current courant absorbé Stromaufnahme stroomopname corriente absorbida absorberet strøm absorbert strøm tillförd ström поглощаемая мощность 电源电流
ART.		(V)	(A)
P315-P316-P317-P318-P319-P320-P321-P322-P323-P324 P325-P326-P327-P328-P363-P364-P365-P366-P367-P368 P329-P330-P331-P332-P333-P334-P335-P336-P337-P338 P339-P340-P378-P379-P380-P381-P382-P383		31,9	0,25
P341-P342-P343-P344-P345-P348-P349-P350 P351-P354-P355-P356-P357-P358-P359-P369-P370-P384 P385-P372-P373-P374-P375-P387-P388-P389-P390-P391 P392-P393-P394-P395-P396-P397-P398-Q806-Q807-Q809 Q810-Q812-Q813-Q815-Q816-Q817-Q818		35,8	0,3
P346-P347-P352-P353-P360-P361-P362-P371-P376-P377-P386 Q808-Q811-Q814		36,5 Vdc 2700°K 27,3 Vdc 1800°K	0,3 0,006

1.154.933.02 IS09948/02	iGuzzini	TENSIONE DI ALIMENTAZIONE POWER SUPPLY VOLTAGE TENSION D'ALIMENTATION VERSORGUNGSSPANNUNG VOEDINGSSPANNING TENSÓN DE ALIMENTACIÓN FORSYNINGSSPÆNDING SPENNING STRØMTILFØRSEL MATNINGSSPÄNNING напряжение электропитания 主电压	corrente assorbita absorbed current courant absorbé Stromaufnahme stroomopname corriente absorbida absorberet strøm absorbert strøm tillförd ström поглощаемая мощность 电源电流
ART.		(V)	(A)
P315-P316-P317-P318-P319-P320-P321-P322-P323-P324 P325-P326-P327-P328-P363-P364-P365-P366-P367-P368 P329-P330-P331-P332-P333-P334-P335-P336-P337-P338 P339-P340-P378-P379-P380-P381-P382-P383		31,9	0,25
P341-P342-P343-P344-P345-P348-P349-P350 P351-P354-P355-P356-P357-P358-P359-P369-P370-P384 P385-P372-P373-P374-P375-P387-P388-P389-P390-P391 P392-P393-P394-P395-P396-P397-P398-Q806-Q807-Q809 Q810-Q812-Q813-Q815-Q816-Q817-Q818		35,8	0,3
P346-P347-P352-P353-P360-P361-P362-P371-P376-P377-P386 Q808-Q811-Q814		36,5 Vdc 2700°K 27,3 Vdc 1800°K	0,3 0,006

1.154.933.02 IS09948/02	iGuzzini	TENSIONE DI ALIMENTAZIONE POWER SUPPLY VOLTAGE TENSION D'ALIMENTATION VERSORGUNGSSPANNUNG VOEDINGSSPANNING TENSÓN DE ALIMENTACIÓN FORSYNINGSSPÆNDING SPENNING STRØMTILFØRSEL MATNINGSSPÄNNING напряжение электропитания 主电压	corrente assorbita absorbed current courant absorbé Stromaufnahme stroomopname corriente absorbida absorberet strøm absorbert strøm tillförd ström поглощаемая мощность 电源电流
ART.		(V)	(A)
P315-P316-P317-P318-P319-P320-P321-P322-P323-P324 P325-P326-P327-P328-P363-P364-P365-P366-P367-P368 P329-P330-P331-P332-P333-P334-P335-P336-P337-P338 P339-P340-P378-P379-P380-P381-P382-P383		31,9	0,25
P341-P342-P343-P344-P345-P348-P349-P350 P351-P354-P355-P356-P357-P358-P359-P369-P370-P384 P385-P372-P373-P374-P375-P387-P388-P389-P390-P391 P392-P393-P394-P395-P396-P397-P398-Q806-Q807-Q809 Q810-Q812-Q813-Q815-Q816-Q817-Q818		35,8	0,3
P346-P347-P352-P353-P360-P361-P362-P371-P376-P377-P386 Q808-Q811-Q814		36,5 Vdc 2700°K 27,3 Vdc 1800°K	0,3 0,006

1.154.933.02 IS09948/02	iGuzzini	TENSIONE DI ALIMENTAZIONE POWER SUPPLY VOLTAGE TENSION D'ALIMENTATION VERSORGUNGSSPANNUNG VOEDINGSSPANNING TENSÓN DE ALIMENTACIÓN FORSYNINGSSPÆNDING SPENNING STRØMTILFØRSEL MATNINGSSPÄNNING напряжение электропитания 主电压	corrente assorbita absorbed current courant absorbé Stromaufnahme stroomopname corriente absorbida absorberet strøm absorbert strøm tillförd ström поглощаемая мощность 电源电流
ART.		(V)	(A)
P315-P316-P317-P318-P319-P320-P321-P322-P323-P324 P325-P326-P327-P328-P363-P364-P365-P366-P367-P368 P329-P330-P331-P332-P333-P334-P335-P336-P337-P338 P339-P340-P378-P379-P380-P381-P382-P383		31,9	0,25
P341-P342-P343-P344-P345-P348-P349-P350 P351-P354-P355-P356-P357-P358-P359-P369-P370-P384 P385-P372-P373-P374-P375-P387-P388-P389-P390-P391 P392-P393-P394-P395-P396-P397-P398-Q806-Q807-Q809 Q810-Q812-Q813-Q815-Q816-Q817-Q818		35,8	0,3
P346-P347-P352-P353-P360-P361-P362-P371-P376-P377-P386 Q808-Q811-Q814		36,5 Vdc 2700°K 27,3 Vdc 1800°K	0,3 0,006

1.154.933.02 IS09948/02	iGuzzini	TENSIONE DI ALIMENTAZIONE POWER SUPPLY VOLTAGE TENSION D'ALIMENTATION VERSORGUNGSSPANNUNG VOEDINGSSPANNING TENSÓN DE ALIMENTACIÓN FORSYNINGSSPÆNDING SPENNING STRØMTILFØRSEL MATNINGSSPÄNNING напряжение электропитания 主电压	corrente assorbita absorbed current courant absorbé Stromaufnahme stroomopname corriente absorbida absorberet strøm absorbert strøm tillförd ström поглощаемая мощность 电源电流
ART.		(V)	(A)
P315-P316-P317-P318-P319-P320-P321-P322-P323-P324 P325-P326-P327-P328-P363-P364-P365-P366-P367-P368 P329-P330-P331-P332-P333-P334-P335-P336-P337-P338 P339-P340-P378-P379-P380-P381-P382-P383		31,9	0,25
P341-P342-P343-P344-P345-P348-P349-P350 P351-P354-P355-P356-P357-P358-P359-P369-P370-P384 P385-P372-P373-P374-P375-P387-P388-P389-P390-P391 P392-P393-P394-P395-P396-P397-P398-Q806-Q807-Q809 Q810-Q812-Q813-Q815-Q816-Q817-Q818		35,8	0,3
P346-P347-P352-P353-P360-P361-P362-P371-P376-P377-P386 Q808-Q811-Q814		36,5 Vdc 2700°K 27,3 Vdc 1800°K	0,3 0,006

iGuzzini

LASER COB

MINIMAL/FRAME
WALL WASHER
WHITE/WARM DIMMING

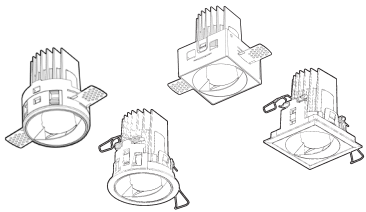

75
mm

I ATTENZIONE:

LA SICUREZZA DELL'APPARECCHIO E' GARANTITA SOLO CON L'USO APPROPRIATO DELLE SEGUENTI ISTRUZIONI; PERTANTO E' NECESSARIO CONSERVARLE.

GB WARNING:

THE SAFETY OF THIS FIXTURE IS GUARANTEED ONLY IF YOU COMPLY WITH THESE INSTRUCTIONS; REMEMBER TO CONSERVE IN A SAFE PLACE.

F ATTENTION:

LA SECURITE DE L'APPAREIL N'EST GARANTIE QU'EN CAS D'UTILISATION CORRECTE DES INSTRUCTIONS SUIVANTES; IL FAUT PAR CONSEQUENT LES CONSERVER.

D ACHTUNG:

DIE SICHERHEIT DES GERÄTES WIRD NUR DURCH SACHGEMÄSSE BEFOLGUNG NACHSTEHENDER ANWEISUNGEN GEWÄHRLEISTET; IHRE AUFBEWAHRUNG IST DESHALB SEHR WICHTIG.

NL OPGELET:

DE VEILIGHEID VAN DI ATOESTEL IS SLECHTS DAN GEGARANDEERD ALS INDIEN DE VOLGENDE INSTRUCTIES STRIKT WORDEN TOEGEPAST; DAAROM MOET MEN ZE OOK BEWAREN.

E ATENCION:

LA SEGURIDAD DEL APARATO SE GARANTIZA SOLO CUMPLIENDO CUIDADOSAMENTE LAS SIGUIENTES INSTRUCCIONES; POR ELLO, ES NECESARIO CONSERVARLAS.

DK BEMÆRK:

SIKKERHEDEN VED BRUG AF ARMATURET KAN KUN GARANTERES, HVIS DISSE ANVISNINGER FØLGES; SØRG DERFOR FOR AT GEMME DEM.

N ADVARSEL:

SIKKERHETEN TIL DETTE APPARATET GARANTERES KUN HVIS DU OVERHOLDER DISSE INSTRUKSJONENE; HUSK Å OPPBEVARE DEM PÅ ET TRYGT STED.

S OBSERVERA!

UTRUSTNINGENS SÄKERHET KAN ENDAST GARANTERAS OMDessa ANVISNINGAR RESPEKTERAS I DETALJ. SPARA DÄRFÖR DESSA ANVISNINGAR FÖR FRAMTIDA KONSULTATION.

RUS ВНИМАНИЕ:

МЫ ГАРАНТИРУЕМ БЕЗОПАСНУЮ ЭКСПЛУАТАЦИЮ ИЗДЕЛИЯ ТОЛЬКО ПРИ СОБЛЮДЕНИИ СЛЕДУЮЩИХ ИНСТРУКЦИЙ; С ЭТОЙ ЦЕЛЬЮ НЕОБХОДИМО СОХРАНИТЬ ДАННУЮ БРОШЮРУ.

CN 警告

为确保该装置安全，请遵守操作指示；并于安全场所放置。

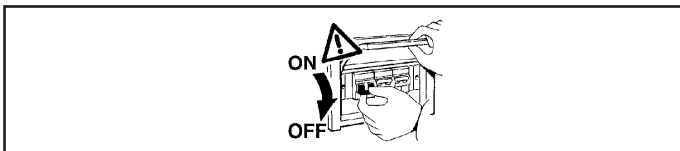

N.B.: DURANTE L'INSTALLAZIONE DEL SISTEMA RISPETTARE SCRUPolosAMENTE LE NORME IMPIANTISTICHE VIGENTI.

N.B.: WHEN INSTALLING THE SYSTEM, STRICTLY COMPLY WITH ALL REGULATIONS ON INSTALLATION IN FORCE.

N.B.: LORS DE L'INSTALLATION DU SYSTÈME VEUILLEZ RESPECTER RIGOREUSEMENT LES NORMES EN VIGUEUR EN LA MATIÈRE.

NB: BEACHTEN SIE BEI DER INSTALLATION DES SYSTEMS GEWISSENHAFT DIE GÜLTIGEN BESTIMMUNGEN BEZÜGLICH DER ANLAGENTECHNIK.

N.B.: BIJ HET INSTALLEREN VAN HET SYSTEEM MOET U DE GELDEN DE INSTALLATIE-NORMEN STRIKT NALEVEN.

N.B.: DURANTE LA INSTALACIÓN DEL SISTEMA RESPETAR E SCRUPolosAMENTE LAS NORMAS DE INSTALACIÓN VIGENTES.

N.B.: UNDER INSTALLATION AF SYSTEMET SKAL MAN NØJE OVERHOLDE DE GÆLDENDE REGLER FOR DISSE ANLÆG.

N.B.: VED INSTALLASJON AV SYSTEMET SKAL ALLE FORSKRIFTER OM INSTALLASJON SOM GJELDER FØLGES STRENGT.

OBS! UNDER INSTALLATIONEN AV SYSTEMET SKA INSTALLATIONSFÖRESKRIFTERNA RESPEKTERAS I DETALJ.

ПРИМЕЧАНИЕ: В ПРОЦЕССЕ МОНТАЖА СИСТЕМЫ СТРОГО СОБЛЮДАЙТЕ НАЦИОНАЛЬНЫЕ ДЕЙСТВУЮЩИЕ НОРМАТИВЫ ПО ЭЛЕКТРОПРОВОДКЕ.

注意：在安装系统时请遵守设备的安装规定。

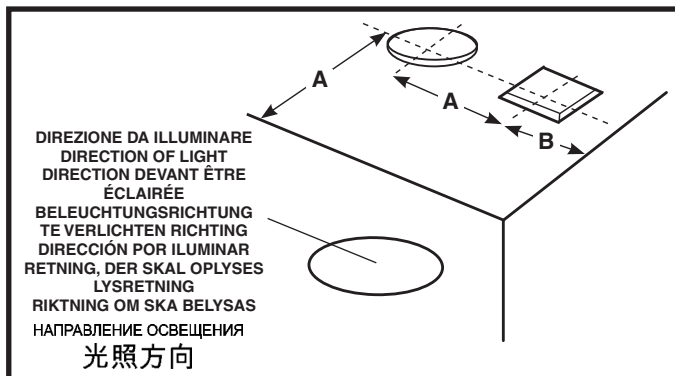
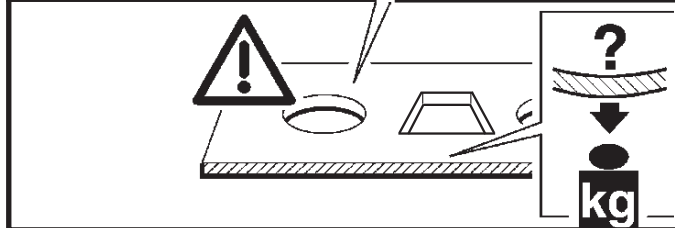
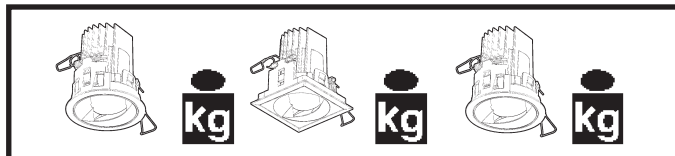
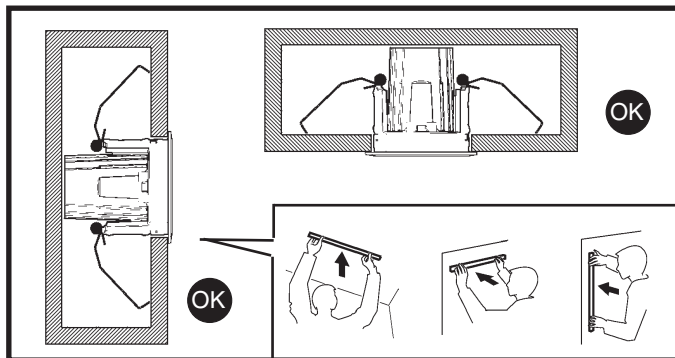
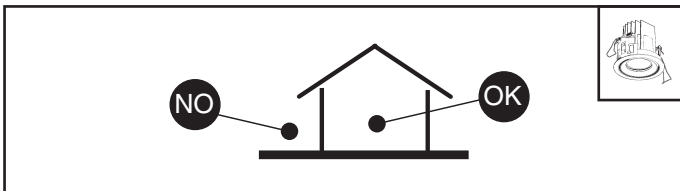

	SUGGERITO SUGGESTED SUGGESTION EMPFOHLEN AANBEVOLEN SUGERIDO FORESLÆT FORSLAG FÖRESLAGEN Рекомендуемая дистанция mm	MAX mm
A	800	1000
B	A 1/2	A 1/2

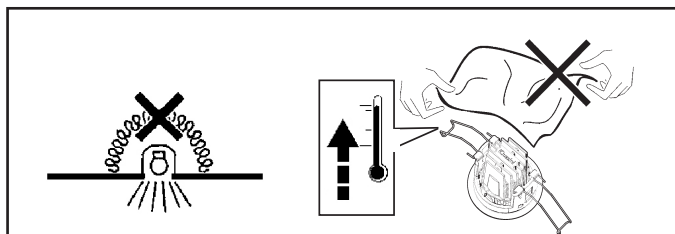

I N.B.: Apparecchi non idonei ad essere coperti di materiale termicamente isolante
 GB N.B.: Fixtures not suitable to be covered in thermally-insulating material.
 F N.B.: Appareils ne pouvant pas être couverts de matériau d'isolation thermique
 N.B.: Geräte nicht geeignet, um mit wärmeisolierendem Material abgedeckt zu werden
 D N.B.: Deze apparaten zijn niet geschikt om te worden bedekt met thermisch isolerend materiaal
 NL
 E NOTA: Aparatos no aptos para ser cubiertos de material térmicamente aislante
 DK N.B.: Armaturerne må ikke dækkes af varmeisolerende materiale.
 N N.B.: Apparaten passer ikke til å dekkes av termoisolerende materialer.
 S OBS! Utrustningen får inte täckas över med värmeisolerande material
 RUS При использовании не рекомендуется для покрытия термическими изоляционными материалами.
 CN 灯具不宜用隔热材料加以覆盖。

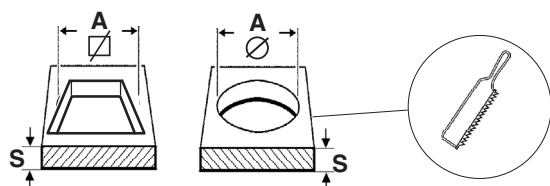
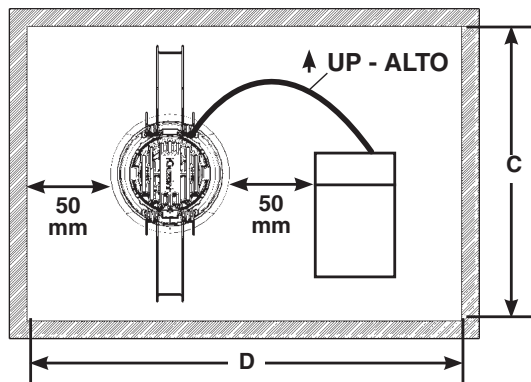
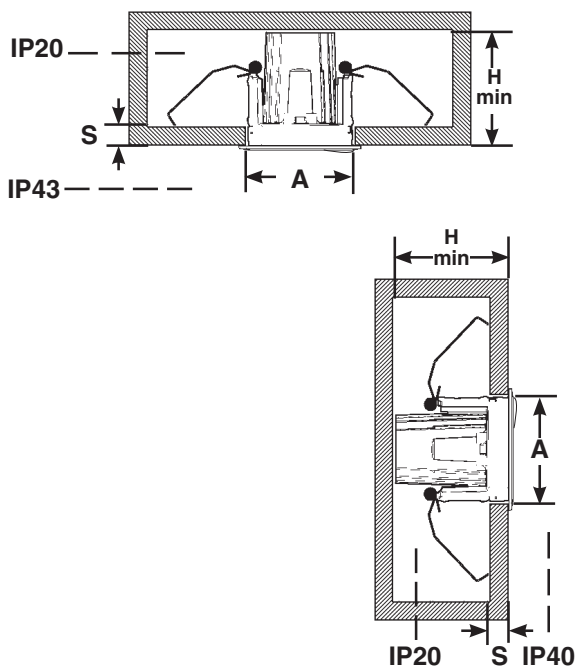

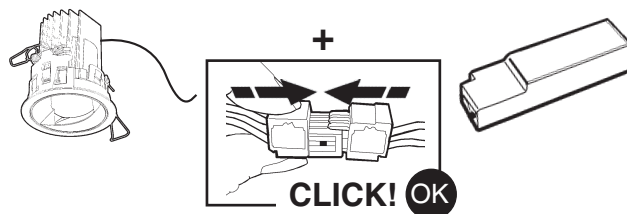

ART.		A +2 mm -0	C mm	D mm	H mm	S mm
P369-P370 P391-P392	MY18	Ø 75	300	270	100	FRAME
	MY19 MY20 MY37				110	
P371	MY19			270	110	1 ± 25
P384-P385 P397-P398	MY18	Ø 75	300	270	100	MINIMAL
	MY37			270	130	
	MY19 MY20			270	140	
	12,5					
P386	MY19			270	140	20
						25

- I** Le prestazioni e la sicurezza dell'apparecchio sono garantite soltanto per oscillazioni della corrente del $\pm 5\%$ rispetto al valore nominale.
La conformità alla norma è garantita soltanto utilizzando trasformatori iGuzzini (art.: MY10 - MY18 - MY19 - MY20 - MY37).
- GB** The performance level and safety of the lighting fixture are only guaranteed for oscillations of $\pm 5\%$ in the current, in relation to the nominal value.
Conformity with the standard is guaranteed only if either iGuzzini transformers (item code MY10 - MY18 - MY19 - MY20 - MY37)
- F** Les performances et la sécurité de l'appareil ne sont assurées que pour des oscillations de courant de $\pm 5\%$ par rapport à la valeur nominale.
La conformité à la norme n'est assurée qu'en cas d'utilisation de transformateurs iGuzzini (réf. : MY10 - MY18 - MY19 - MY20 - MY37)
- D** Die Leistungen und die Sicherheit des Geräts sind nur für vom Vorschaltgerät abgehende Spannungsschwankungen von $\pm 5\%$ in Bezug auf den Nennwert gewährleistet.
Die Übereinstimmung mit den Vorschriften ist nur bei Verwendung von iGuzzini-Transformatoren (Art.: MY10 - MY18 - MY19 - MY20 - MY37)
- NL** De prestaties en de veiligheid van het apparaat zijn alleen gegarandeerd voor spanningsvariaties van $\pm 5\%$ ten opzichte van de nominale waarde.
De conformiteit aan de norm wordt alleen gegarandeerd als u iGuzzini voorschakelapparaten gebruikt (art.: MY10 - MY18 - MY19 - MY20 - MY37)
- E** Las prestaciones y la seguridad del aparato están garantizada solamente con oscilaciones de la corriente del $\pm 5\%$ respecto al valor nominal.
La conformidad a la norma se garantiza solamente con el uso de transformadores iGuzzini (art. MY10 - MY18 - MY19 - MY20 - MY37)
- DK** Armaturets ydelse og sikkerhed kan kun garanteres ved strømudsving på $\pm 5\%$ i forhold til den nominelle værdi.
Opfyldelse af reglerne garanteres kun ved brug af transformatorer fra iGuzzini (art.: MY10 - MY18 - MY19 - MY20 - MY37)
- N** Ytelsesnivået og sikkerheten til lysarmaturen kan kun garanteres for svingninger på $\pm 5\%$ i strømmen, i forhold til nominell verdi.
Overhold av standarden garanteres kun hvis enten iGuzzini-transformere (art. MY10 - MY18 - MY19 - MY20 - MY37)
- S** Utrustningens prestanda och säkerhet garanteras endast vid en strömoscillation på $\pm 5\%$ i förhållande till nominellt värde.
Överensstämmelse med standard garanteras endast genom att använda transformatorer av typ iGuzzini (art.: MY10 - MY18 - MY19 - MY20 - MY37)
- RUS** Эксплуатационные качества и безопасность прибора гарантируются только при колебаниях тока $\pm 5\%$ от номинального значения.
Соответствие нормативу гарантируется только при использовании трансформаторов iGuzzini (art. MY10 - MY18 - MY19 - MY20 - MY37).
- CN** 只有在电流的额定值 $\pm 5\%$ 的情况，才可以保证装置的使用性能及安全性
只有在使用iGuzzini的供电器 (MY10 - MY18 - MY19 - MY20 - MY37号产品)

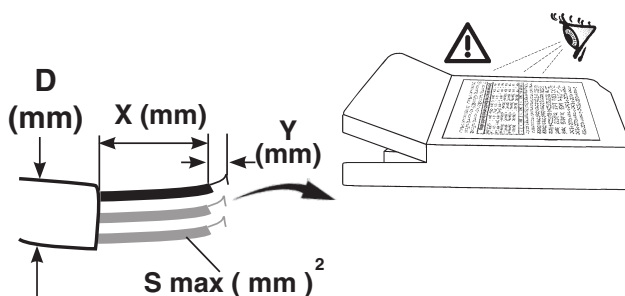

- I** Cablare alla rete elettrica il trasformatore solo dopo aver effettuato il collegamento ai prodotti
- GB** Wire the transformer to the electrical mains only after the connection to the products has been carried out
- F** N'effectuer le câblage au réseau électrique qu'après avoir effectué le raccordement aux produits
- D** Schließen Sie den Transformator erst nach der Verdrahtung an den Produkten am Stromnetz an.
- E** Cablear el transformador a la red eléctrica sólo después de conectar los productos
- NL** Verbind de transformator alleen op het elektrische net nadat u alle producten heeft aangesloten.
- DK** Tilslut først transformatoren til strømforsyningsnettet, efter at have foretaget tilslutningen til produkterne.
- N** Omformeren skal kun kobles til strømnettet etter at tilkoblingen til produktene er gjennomført.
- S** Anslut transformatorn till elnätet först efter att anslutningen till produkterna har utförts.
- RUS** Подвести кабель трансформатора к электрической сети, только после соединения с продуктами
- CN** 只有连接灯具后，才可以把变压器连接到电源线上。



	S mm ²	Y mm	X mm	D mm
GITRONICA	1,5	8 - 9	40	/
TRIDONIC	0,5 - 1,5	8,5 - 9,5	40	
PHILIPS Xitanium	0,2 - 1,5	8 - 9	40	
TCI MINI JOLLY LC	0,5 - 1,5	8,5 - 9,5	30	3 - 8
TCI DC JOLLY MD LC	0,5 - 2,5	5,5 - 6,5	25	
ALVIT ALD	2,5	9 - 10	25	/
OSRAM OTI DALI	0,2 - 1,5	8 - 9	30	

DALI Art. MY19

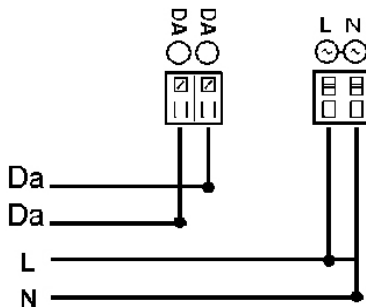

TOUCH DIM Art. MY19

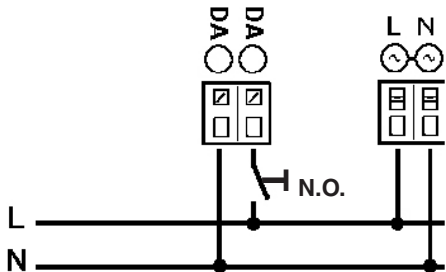

Art. MY19

I I dispositivi con cablaggio digitale possono essere dimmerati con dispositivi DALI o con pulsante normalmente aperto (N.O.) da collegare come da schema.

GB Devices with digital control gear may be dimmed using DALI devices or a normally-open button (N.O.) to be connected as shown in the diagram.

F Les articles à câblage numérique peuvent fonctionner avec des variateurs à dispositifs DALI ou à bouton poussoir normalement ouvert (N.O.) à relier conformément au schéma.

D Die Geräte mit digitaler Verkabelung können mit Hilfe von DALI-Vorrichtungen oder mit Hilfe eines gemäß Schaltplan anzuschließenden Schließers (N.O.) gedimmt werden.

NL De producten met digitale bekabeling kunnen worden gedimd met DALI systemen of met een N.O. (normally open) knop, die moet worden aangesloten volgens schema.

E Los dispositivos con cableado digital pueden regularse con dispositivos DALI o con un interruptor de botón normalmente abierto (N.O.) que se conecta según ilustrado en el esquema.

DK Produkter med digital kabelføring kan dæmpes med DALI-anordninger eller med kontakten, som normalt er åben (N.O.) og som skal tilsluttes, som vist.

N Produkter med digitalkabler kan dimmes med DALI-anordninger eller med en normalt åpen (NO) trykkbryter som kobles som vist i koblingsskjema.

S Produkter med digital kabeldragning kan förses med dimmer. Detta kan göras med DALI-anordningarna eller med en normalt öppen kontakt (N.O.) som ska anslutas enligt schemat.

RUS Интенсивность приборов с цифровой проводкой может регулироваться посредством устройств DALI или нормально разомкнутой кнопкой (Н.Р.), подсоединяемой согласно схеме.

CN 带有数字控制装置的设备可以通过 DALI (数字化可寻址调光接口) 设备或者一个连接方式如图中所示的常开按钮 (N.O.) 进行亮度调节

I Pilotare diversi prodotti DALI tramite pulsante (es: Touch-dim, Switch-dim, Push-dim, Direct-dim, etc.) potrebbe causare dei problemi di sincronizzazione tra gli stessi. È possibile ovviare a questo problema dotandosi di dispositivi aggiuntivi. Per maggiori informazioni vi invitiamo a contattarci direttamente.

GB Controlling different DALI products through buttons (e.g.: Touch-dim, Switch-dim, Push-dim, Direct-dim, etc.) may lead to product synchronisation problems. This problem can be overcome by using additional devices. For further information, please contact us directly.

F Pilote plusieurs produits DALI par bouton (ex : Touch-dim, Switch-dim, Push-dim, Direct-dim, etc.) pourrait causer des problèmes de synchronisation entre eux. Ce problème peut être évité en s'équipant de dispositifs supplémentaires. Pour de plus amples renseignements, veuillez nous contacter directement.

D Die Steuerung verschiedener DALI-Produkte mittels Taste (z.B.: Touch-dim, Switch-dim, Push-dim, Direct-dim etc.) kann eventuell zu Synchronisierungsproblemen zwischen diesen führen. Dieses Problem lässt sich durch den Einsatz von zusätzlichen Geräten beheben. Wenn Sie weitere Informationen wünschen, setzen Sie sich bitte direkt mit uns in Verbindung.

NL Het besturen van verschillende DALI producten m.b.v. dezelfde knop (bv.: Touch-dim, Switch-dim, Push-dim, Direct-dim, etc.) kan synchronisatieproblemen tussen de producten opleveren. Men kan dit probleem voorkomen door extra systemen aan te sluiten. Voor verdere informatie raden we u aan direct contact met ons op te nemen.

E El mando de varios productos DALI por tecla (ej: Touch-dim, Switch-dim, Push-dim, Direct-dim, etc.) podría causar problemas de sincronización entre ellos. Es posible prevenir este problema utilizando dispositivos adicionales. Para más información, contacte directamente con nosotros.

DK Hvis DALI-produkterne styres ved hjælp af knapperne (fx. Touch-dim, Switch-dim, Push-dim, Direct-dim osv.), kan det skabe problemer med synkronisering af samme. Dette problem kan undgås, hvis man kober ekstra enheder. For yderligere oplysninger, kontakt os direkte.

N Å styre ulike DALI-produkter ved hjelp av en trykknappbryter (f.eks. touch-dim, switch-dim, push-dim, direct-dim, osv.) vil kunne føre til problemer med synkroniseringen mellom dem. Dette problemet kan løses ved hjelp av noen tilleggsinnretninger. Ta gjerne kontakt med oss for mer informasjon om dette.

S Styrning av olika DALI-produkter med knapp (f.ex.: Touch-dim, Switch-dim, Push-dim, Direct-dim o.s.v.) kan orsaka synkroniseringsproblem mellan dessa. Detta problem kan åtgärdas med tillägsanordningar. För mer information kan du kontakta oss direkt.

RUS Управление различными продуктами DALI с помощью кнопки (напр.: Touch-dim, Switch-dim, Push-dim, Direct-dim и пр.) может вызвать проблемы синхронизации между ними. Эту проблему можно устранить путем задействования дополнительных устройств. За получением более подробной информации просим Вас связаться с нами непосредственно.

CN 通过按钮控制不同的 DALI 产品 (例如: 触摸调光、切换调光、按压调光、直接调光等) 可能会导致产品的同步问题。该问题可通过使用其他额外的装置加以克服。如需了解更多信息, 请直接与我们联系。

ART. MY19

CARICO DALI / DALI LOAD
CHARGE DALI
(COURANT MAXI ADMISSIBLE)
DALI-LAST
DALI VERMOGEN
CARGA DALI
DALI STRÖMSTYRKE
BELASTNING FOR "DALI"
DALI-BELASTNING
МАКС. ТОК СИСТЕМЫ DALI С
РЕГУЛЯЦИЕЙ ИНТЕНСИВНОСТИ
СВЕТА
DALI 智能调光系统允许的最大电流量

INDIRIZZI DALI
DALI ADDRESSES
ADRESSES DALI
DALI-ADRESSEN
DALI ADRESSEN
DIRECCIONES DALI
DALI ADRESSER
ADRESSER TIL "DALI"
DALI-ADRESSER
ЛОГИЧЕСКИЕ АДРЕСА
СИСТЕМЫ DALI
DALI智能调光系统计算机指定控制参数



ART.

1

1

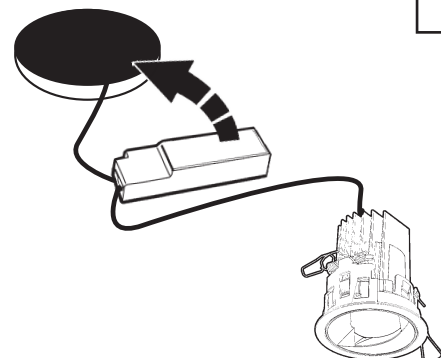
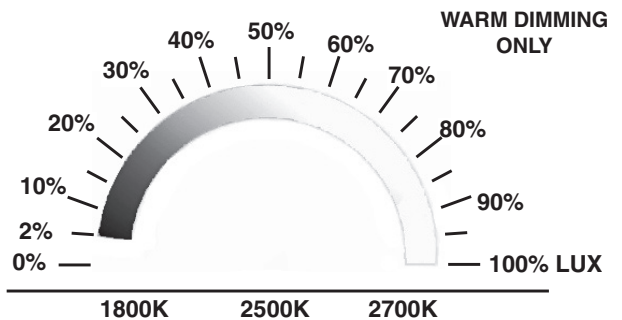

FRAME

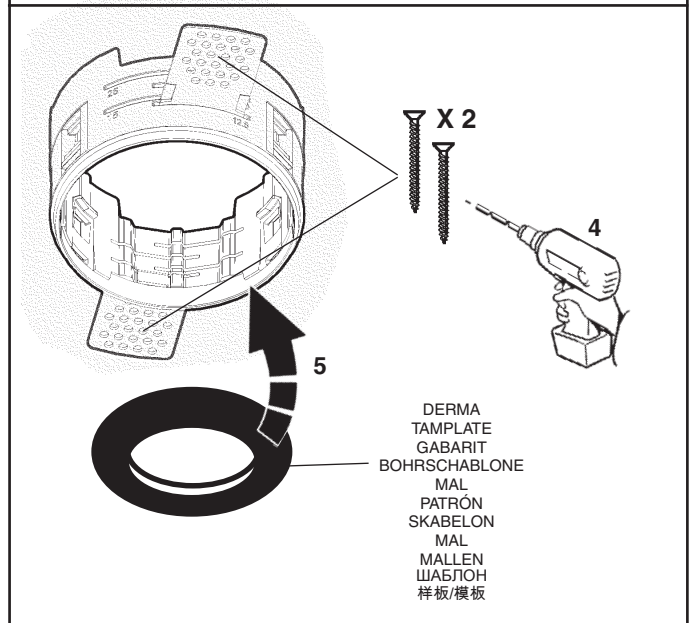
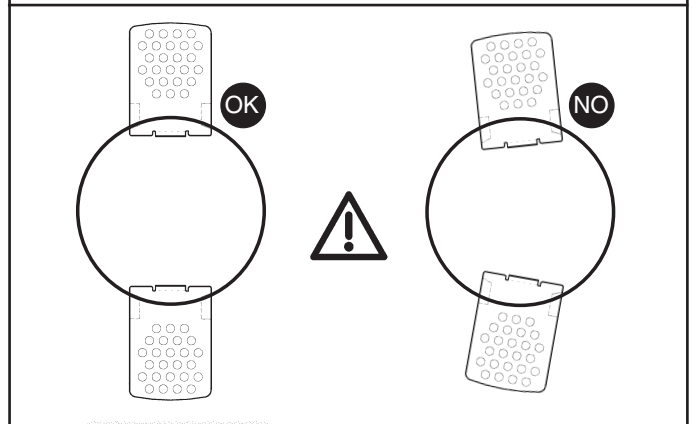
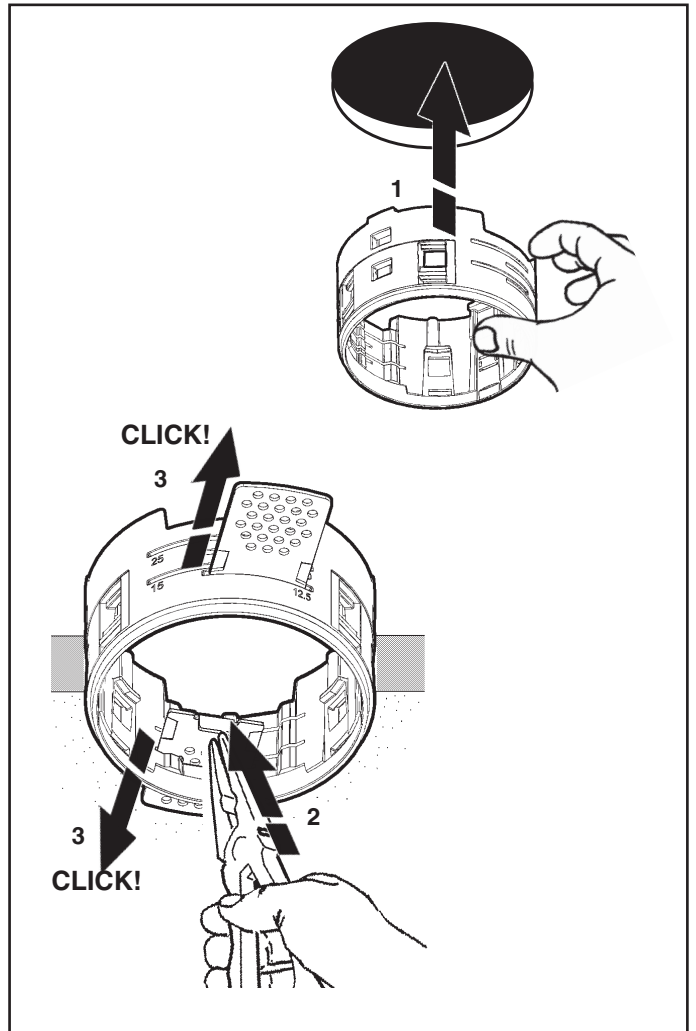
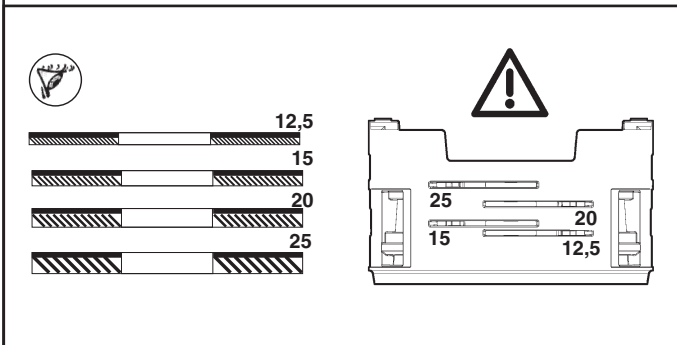
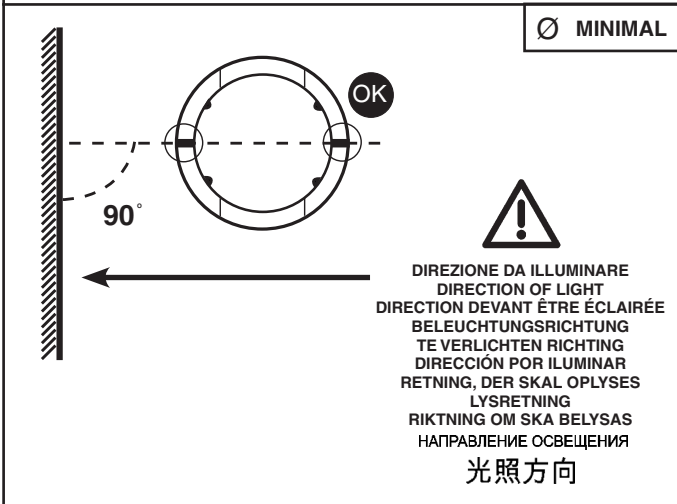
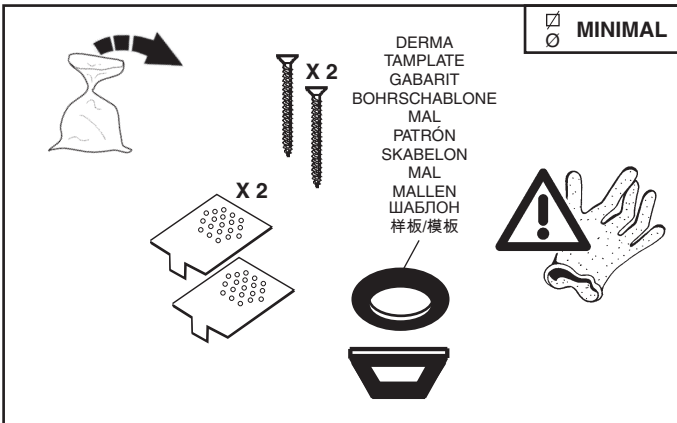
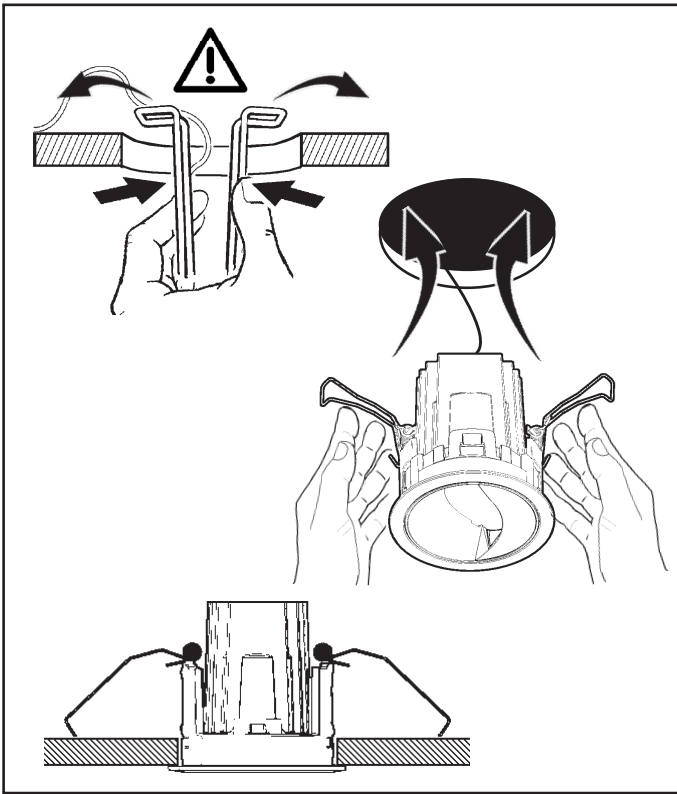

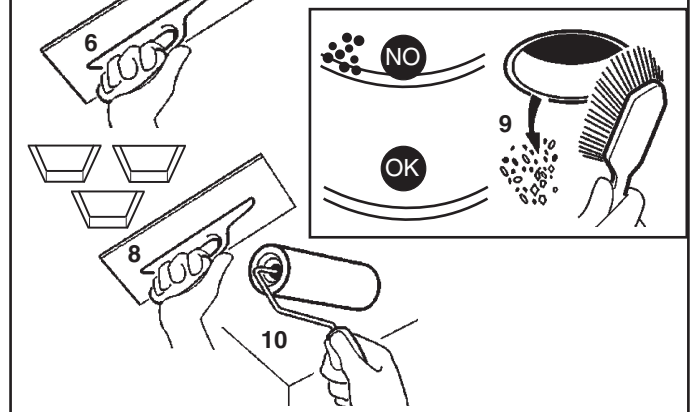
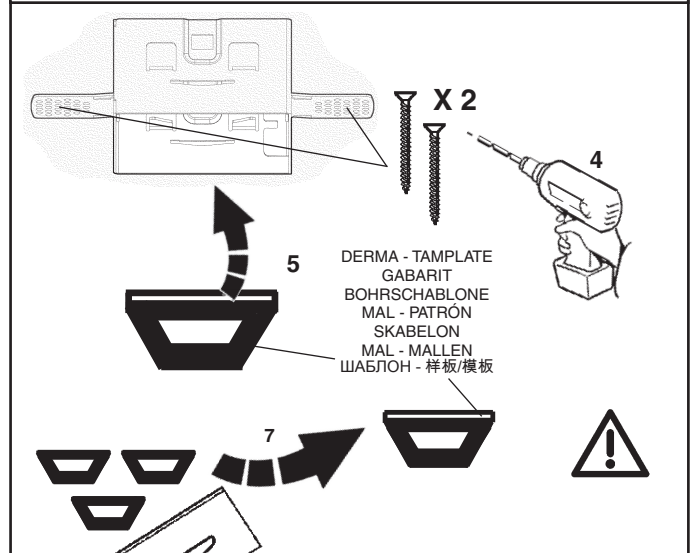
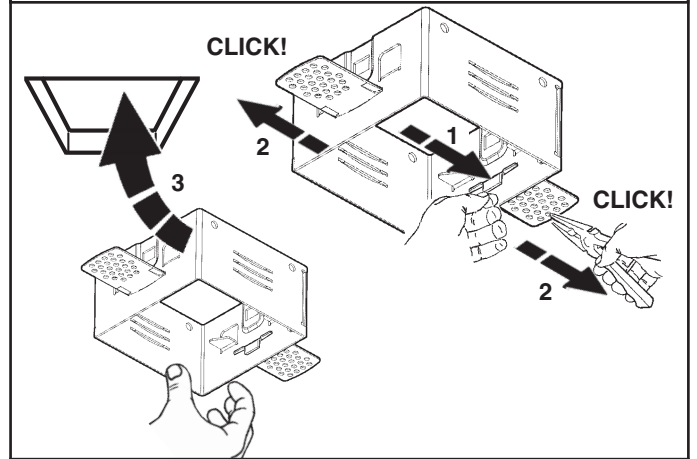
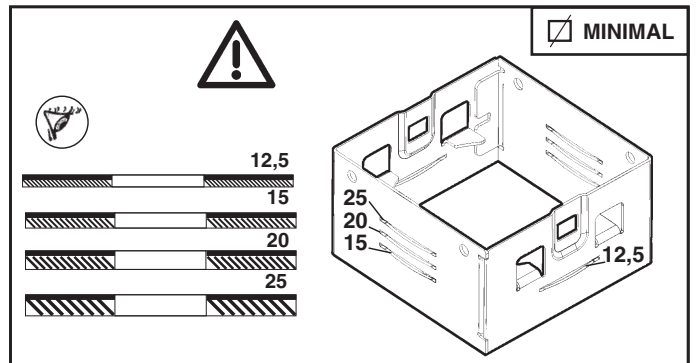
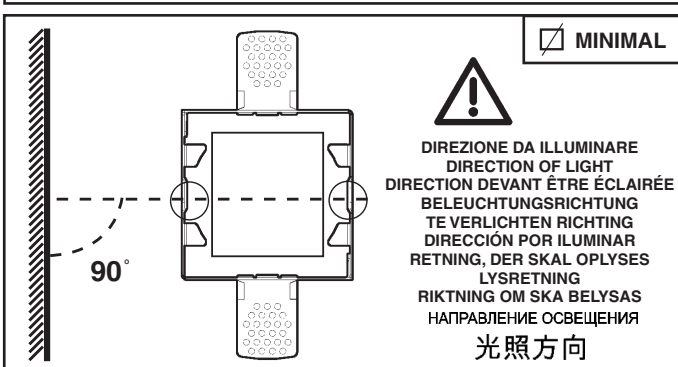
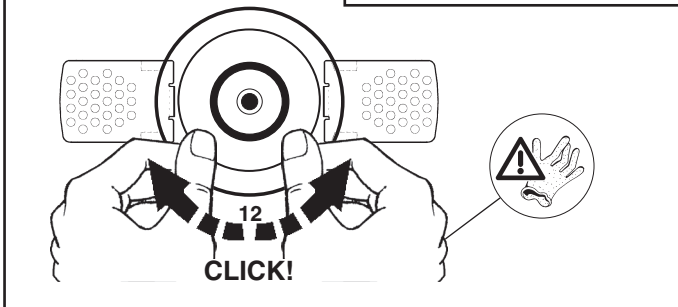
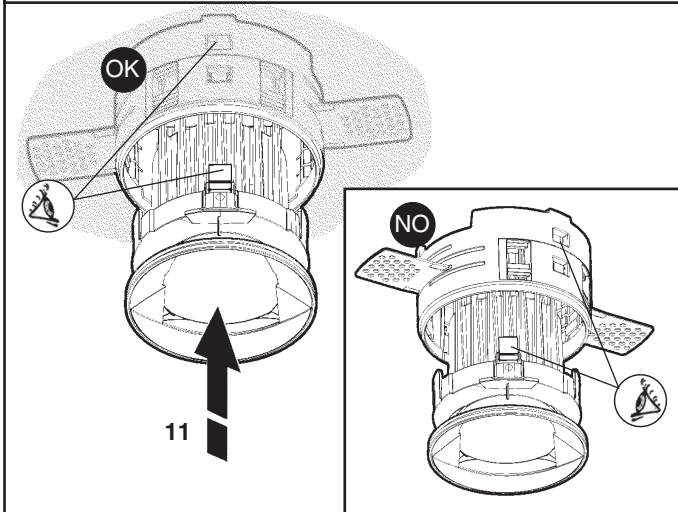
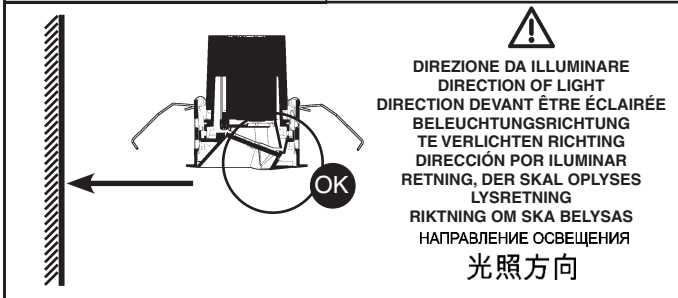
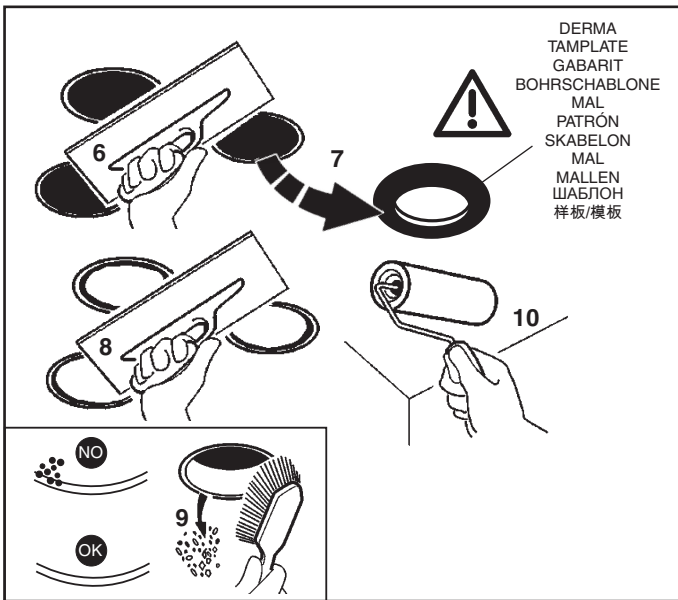

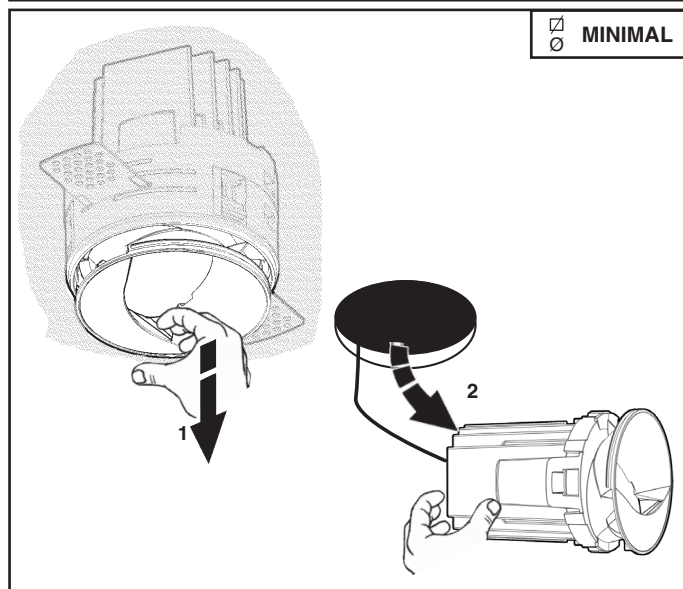
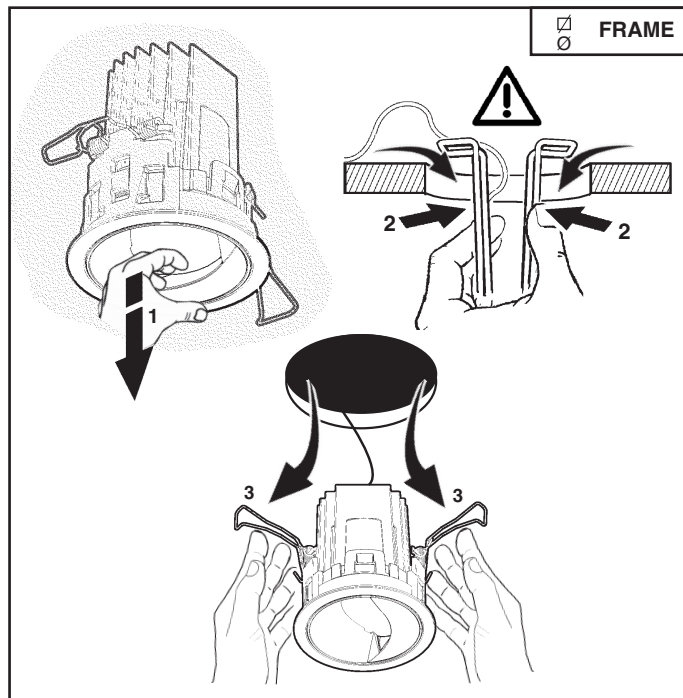
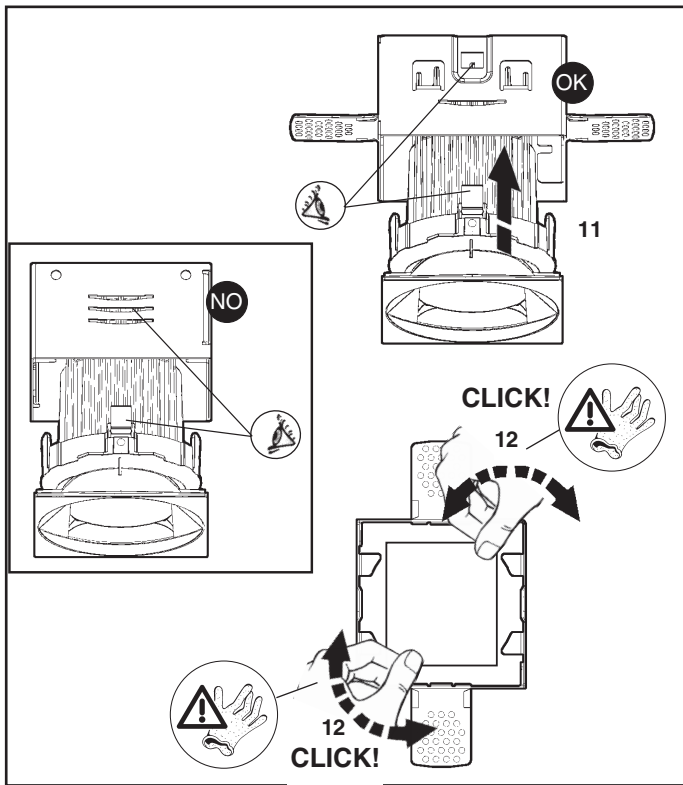

I In caso di rottura del vetro il prodotto non può essere utilizzato, contattare il costruttore per la sua sostituzione.

GB Should the glass break, the product cannot be used and you should contact the manufacturer for its replacement.

F En cas d'endommagement de l'écran de protection le produit ne peut pas être utilisé, contactez le fabricant pour le remplacement.

D Falls das Glas kaputt sein sollte, kann das Produkt nicht verwendet werden. Kontaktieren Sie in dem Fall den Hersteller, um das Glas zu ersetzen.

NL Als het glas gebroken is kan het apparaat niet worden gebruikt en moet u zich tot de fabrikant wenden voor het vervangen van het glas.

E No utilizar el producto en caso de ruptura del vidrio y contactar el fabricante para la sustitución.

DK Hvis produktets glas ødelægges, kan det ikke anvendes. Kontakt forhandleren med henblik på udskiftning.

N Hvis glasset skulle knuses, kan ikke produktet brukes, og du må ta kontakt med produsenten for å få det skiftet.

S Om glaset går sönder kan inte produkten användas. Kontakta tillverkaren för att byta ut glaset.

RUS В случае разбивания стекла не используйте прибор, обратитесь к его производителю для замены.

CN 且玻璃破碎后产品将不能再用，须联系生产商予以更换。

I N.B.: Per la sostituzione del LED contattare l'azienda iGuzzini.

GB N.B.: For information on LED replacement please contact iGuzzini.

F N.B.: Pour procéder au remplacement de la LED, adressez-vous à la société iGuzzini.

D N.B.: Bezüglich des Austausches der LED kontaktieren Sie bitte die Firma iGuzzini.

NL N.B.: Voor het vervangen van de LED neemt u contact op met het bedrijf iGuzzini.

E NOTA: Para sustituir el LED llame a la empresa iGuzzini.

DK N.B.: For udskiftning af lysdioden, skal man kontakte iGuzzini.

N N.B.: For informasjon om skifte av LED, vennligst ta kontakt med iGuzzini.

S OBS! För byte av lysdioden, kontakta företaget iGuzzini.

RUS ПРИМЕЧАНИЕ: Для замены СИДов обращайтесь в компанию iGuzzini.

CN 注意：如需LED更换的信息，请联系iGuzzini。

I ATTENZIONE: per l'utilizzo del kit emergenza art. MY21 – MY36 e le compatibilità con i prodotti, fare riferimento al foglio istruzioni del kit emergenza.

GB WARNING: see the emergency kit instruction sheet for how to use the art. MY21 – MY36 emergency kit and its product compatibility.

F ATTENTION : pour l'utilisation du kit de secours réf. MY21 – MY36 et les compatibilités avec les produits, veuillez consulter Interior Luminaire of the year/Interior Luminaire of the year/la notice du kit.

D ACHTUNG: für die Verwendung des Notfall-Sets Art.nr. MY21 – MY36 und seine Vereinbarkeit mit den verschiedenen Produkten das Anleitungsbild des Notfall-Sets einsehen.

NL OPGELET: raadpleeg het instructieblad van de kit noodverlichting voor het gebruik van de kit noodverlichting art. MY21 – MY36 en de compatibiliteit met de producten.

E ATENCIÓN: para más información sobre el uso del kit de emergencia art. MY21 – MY36 y la compatibilidad con los productos, consultar la hoja de instrucciones del kit de emergencia.

DK BEMÆRK: for anvendelse af nødsættet art. MY21 – MY36 og kompatibilitet med produkterne henvises til instruktionsbogen for nødsættet.

N ADVARSEL: for bruk av nødsettet MY21 – MY36 og kompatibilitet med produktene, se instruksjonsarket til nødsettet.

S OBSERVERA: för information om användning av nödlägeskitet med artikelnr. MY21 – MY36 och dess kompatibilitet med produkterna hänvisar vi till nödlägeskitets bruksanvisning.

RUS ВНИМАНИЕ: Информацию по использованию аварийных комплектов art. № MY21 – MY36 и совместимости продуктов смотрите в инструкциях к аварийным комплектам.

CN 注意：有关应急套件MY21 – MY36的使用和与其他产品的兼容性，请参考应急套件的说明书。

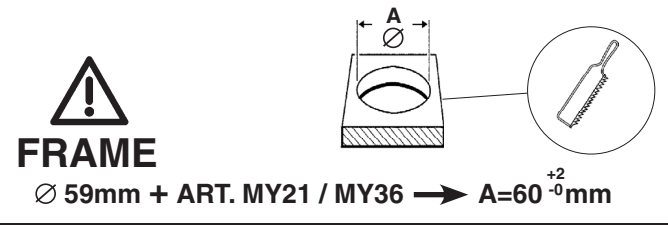

2.509.525.00
IS12978/00

iGuzzini

LASER COB

MINIMAL/FRAME
WALL WASHER
WHITE/WARM DIMMING

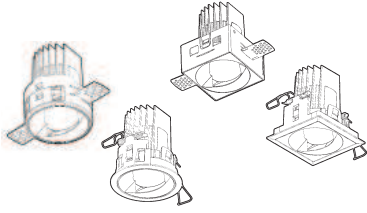

Ø ▽

75
mm

AR

تحذير:

لا يمكن ضمان سلامة هذا الجهاز إلا إذا التزمت بهذه التعليمات، يجب حفظها في مكان آمن.

IT ATTENZIONE:

LA SICUREZZA DELL'APPARECCHIO E' GARANTITA SOLO CON L'USO APPROPRIATO DELLE SEGUENTI ISTRUZIONI; PERTANTO E' NECESSARIO CONSERVARLE.

EN WARNING:

THE SAFETY OF THIS FIXTURE IS GUARANTEED ONLY IF YOU COMPLY WITH THESE INSTRUCTIONS; REMEMBER TO CONSERVE IN A SAFE PLACE.

ES ATENCION:

LA SEGURIDAD DEL APARATO SE GARANTIZA SOLO CUMPLIENDO CUIDADOSAMENTE LAS SIGUIENTES INSTRUCCIONES; POR ELLO, ES NECESARIO CONSERVARLAS.

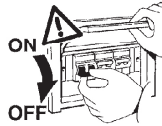

AR

ملاحظة: ملاحظة: أثناء تركيب نظام بحرص بالنظم السائدة المتعلقة بالشبكة الكهربائية. يجب التقيد.

IT N.B.: DURANTE L'INSTALLAZIONE DEL SISTEMA RISPETTARE SCRUPolosAMENTE LE NORME IMPIANTISTICHE VIGENTI.

EN N.B.: WHEN INSTALLING THE SYSTEM STRICTLY COMPLY WITH ALL REGULATIONS ON INSTALLATION IN FORCE.

ES N.B.: DURANTE LA INSTALACIÓN DEL SISTEMA RESPETAR ESCRUPolosAMENTE LAS NORMAS DE INSTALACIÓN VIGENTES.

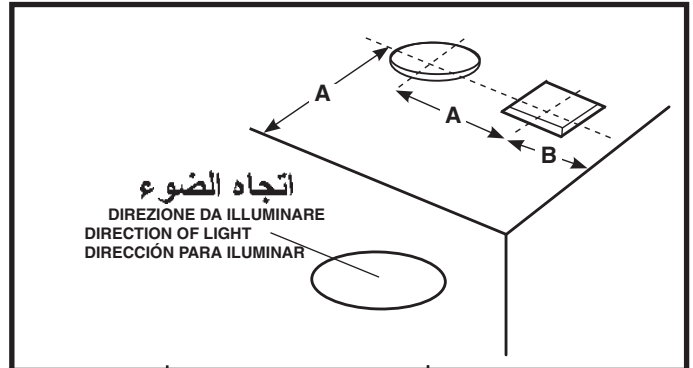
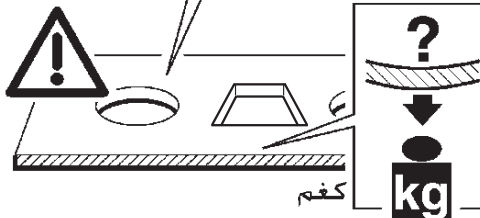
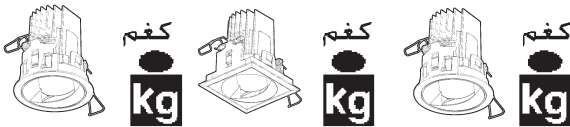
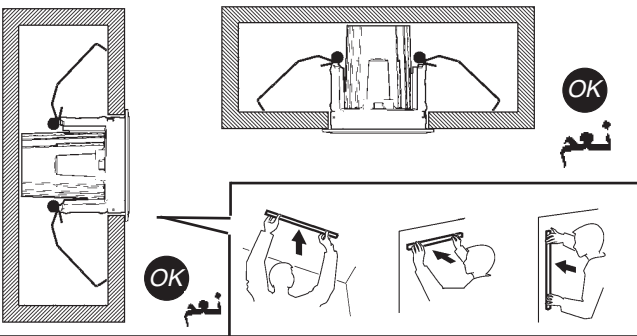
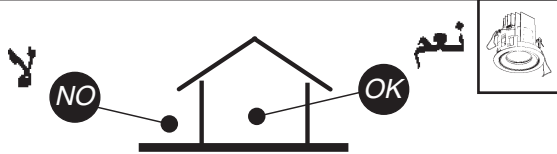

	مقترح SUGGERITO SUGGESTED SUGERIDO mm ملم	MAX mm ملم
A	800	1000
B	A 1/2	A 1/2

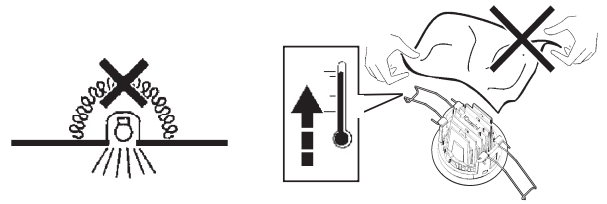

AR

ملاحظة: أجهزة غير قابلة للتغطية مواد عازلة حرارياً.

IT N.B.: Apparecchi non idonei ad essere coperti di materiale termicamente isolante

EN N.B.: Fixtures not suitable to be covered in thermally-insulating material.

ES OBS! Utrustningen får inte täckas över med värmeisolerande material

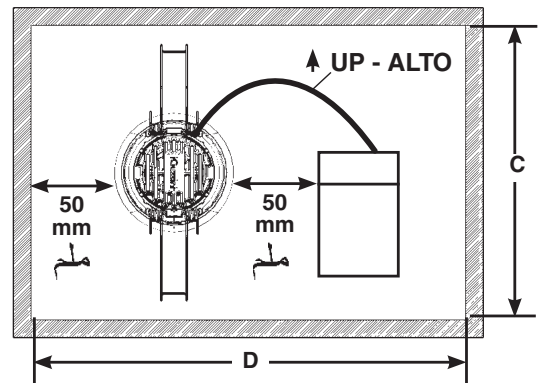
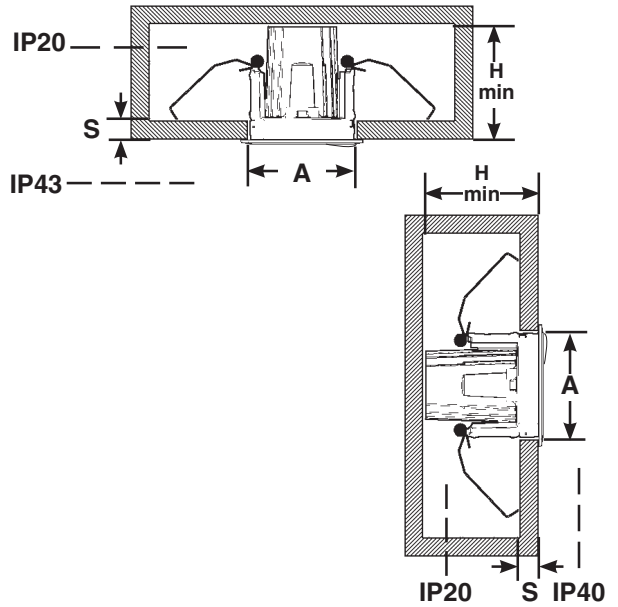

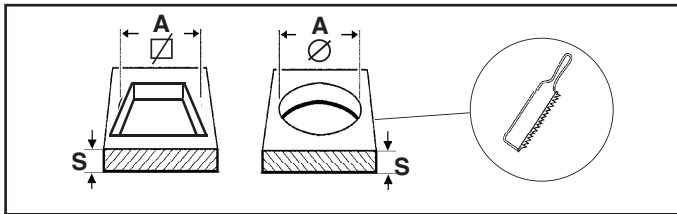

الصنف ART.	الصنف ART.	A mm +2 -0 ملم	C mm ملم	D mm ملم	H mm ملم	S mm ملم
P369-P370 P391-P392	MY18 MY19 MY20 MY37	∅ 75	300	270	100	FRAME 1 ÷ 25
P371	MY19				110	
P384-P385 P397-P398	MY18 MY37 MY19 MY20			∅ 75	300	270
P386	MY19	270	130			
		270	140			
				270	140	

AR يتم ضمان عمل الجهاز بشكل جيد من خلال تأرجح فاطية التغذية الخارجة بنسبة $\pm 5\%$ مقارنة مع القيمة الاسمية.
المطابقة للمعيار مضمونة فقط عند استخدام محولات جودزيني "iGuzzini"
MY10 - MY18 - MY19 - MY20 - MY37

IT Le prestazioni e la sicurezza dell'apparecchio sono garantite soltanto per oscillazioni della corrente del $\pm 5\%$ rispetto al valore nominale.
La conformità alla norma è garantita soltanto utilizzando trasformatori iGuzzini (art.: MY10 - MY18 - MY19 - MY20 - MY37).

EN The performance level and safety of the lighting fixture are only guaranteed for oscillations of $\pm 5\%$ in the current, in relation to the nominal value.
Conformity with the standard is guaranteed only if either iGuzzini transformers (item code MY10 - MY18 - MY19 - MY20 - MY37)

ES Las prestaciones y la seguridad del aparato están garantizada solamente con oscilaciones de la corriente del $\pm 5\%$ respecto al valor nominal.
La conformidad a la norma se garantiza solamente con el uso de transformadores iGuzzini (art. MY10 - MY18 - MY19 - MY20 - MY37)

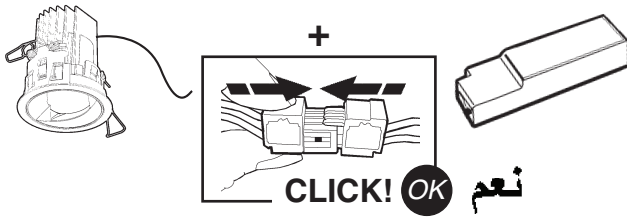

AR **أوصل المحول بالشبكة الكهربائية فقط بعد توصيل المنتجات.**

IT Cablare alla rete elettrica il trasformatore solo dopo aver effettuato il collegamento ai prodotti

EN Wire the transformer to the electrical mains only after the connection to the products has been carried out

ES Cablear el transformador a la red eléctrica sólo después de conectar los productos

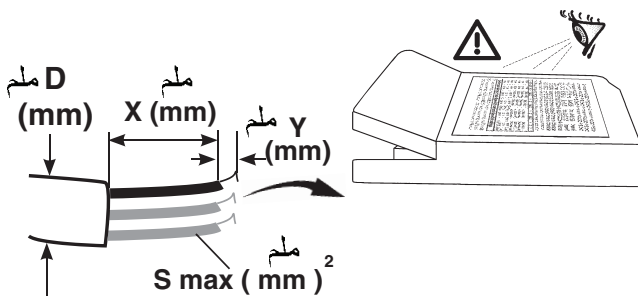

	S mm ² ملم ²	Y mm ملم	X mm ملم	D mm ملم
GITRONICA	1,5	8 - 9	40	
TRIDONIC	0,5 - 1,5	8,5 - 9,5	40	/
PHILIPS Xitanium	0,2 - 1,5	8 - 9	40	
TCI MINI JOLLY LC	0,5 - 1,5	8,5 - 9,5	30	3 - 8
TCI DC JOLLY MD LC	0,5 - 2,5	5,5 - 6,5	25	
ALVIT ALD	2,5	9 - 10	25	/
OSRAM OTI DALI	0,2 - 1,5	8 - 9	30	/

DALI Art. MY19

الصنف

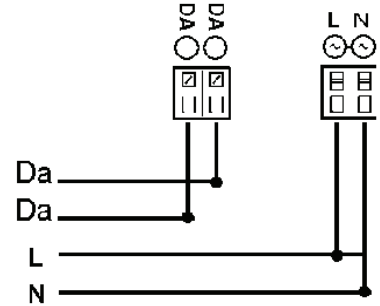

TOUCH DIM Art. MY19

الصنف

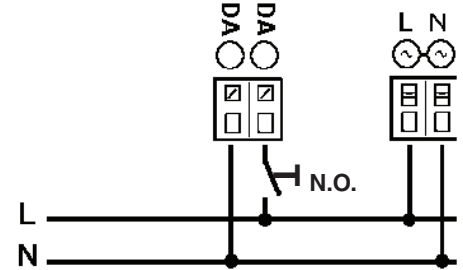

الصنف Art. MY19

AR يمكن أن يتم تخفيض إضاءة الأجهزة ذات الكابلات الرقمية؛ وذلك عن طريق استخدام أجهزة الإمداد بالطاقة الكهربائية "دالي" (DALI)، أو عن طريق استخدام زر يكون مفتوحاً في وضعه الطبيعي (N.O.) ؛ حيث يتم التوصيل كما هو مبين في المخطط.

IT I dispositivi con cablaggio digitale possono essere dimmerati con dispositivi DALI o con pulsante normalmente aperto (N.O.) da collegare come da schema.

EN Devices with digital control gear may be dimmed using DALI devices or a normally-open button (N.O.) to be connected as shown in the diagram.

ES Los dispositivos con cableado digital pueden regularse con dispositivos DALI o con un interruptor de botón normalmente abierto (N.O.) que se conecta según ilustrado en el esquema.

AR يمكن أن يسبب التحكم في منتجات "دالي" المختلفة عن طريق الأزرار ، (مثل الأزرار ، "تنش - ديم" ، "سويتش - ديم" ، "بوش - ديم" ، "دايركت - ديم" ، إلخ) ، في حدوث مشاكل تتعلق بعملية التزامن بين هذه الأزرار. وإن كان من الممكن تجنب مثل هذه المشاكل، وذلك عن طريق تزويد بعض الأجهزة الإضافية. ندعوكم للاتصال المباشر بالشركة؛ وذلك للحصول على أكبر قدر من المعلومات.

IT Pilotare diversi prodotti DALI tramite pulsante (es: Touch-dim, Switch-dim, Push-dim, Direct-dim, etc.) potrebbe causare dei problemi di sincronizzazione tra gli stessi. È possibile ovviare a questo problema dotandosi di dispositivi aggiuntivi. Per maggiori informazioni vi invitiamo a contattarci direttamente.

EN Controlling different DALI products through buttons (e.g.: Touch-dim, Switch-dim, Push-dim, Direct-dim, etc.) may lead to product synchronisation problems. This problem can be overcome by using additional devices. For further information, please contact us directly.

ES El mando de varios productos DALI por tecla (ej: Touch-dim, Switch-dim, Push-dim, Direct-dim, etc.) podría causar problemas de sincronización entre ellos. Es posible prevenir este problema utilizando dispositivos adicionales. Para más información, contacte directamente con nosotros.

	الصنف ART. MY19	
الصنف 	DALI شحنة / DALI جمل CARICO DALI / DALI LOAD CHARGE DALI CARGA DALI	عناوين DALI INDIRIZZI DALI DALI ADDRESSES DIRECCIONES DALI
	ART.	1

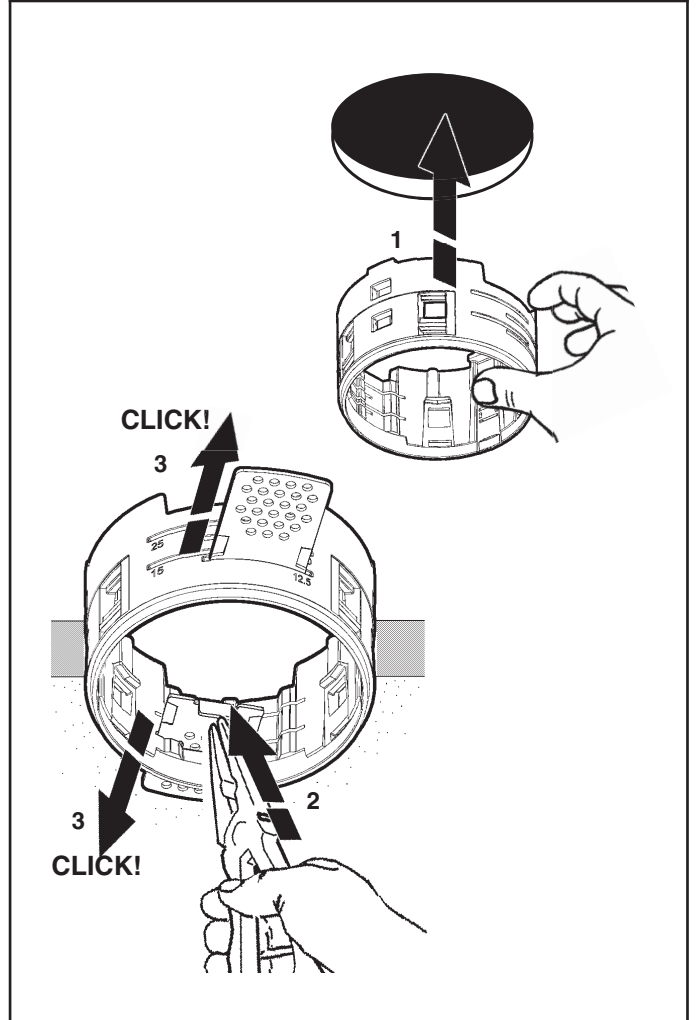
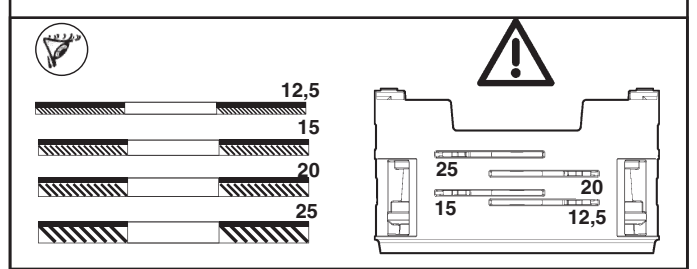
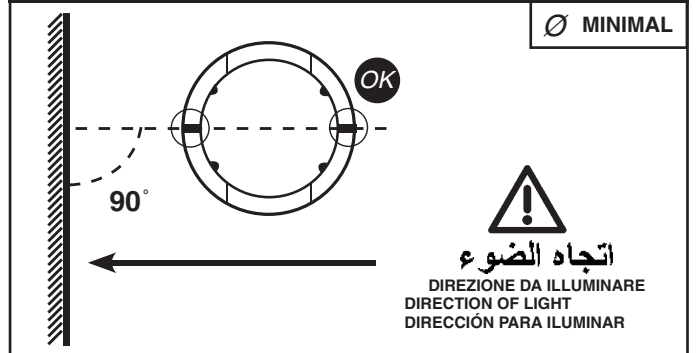
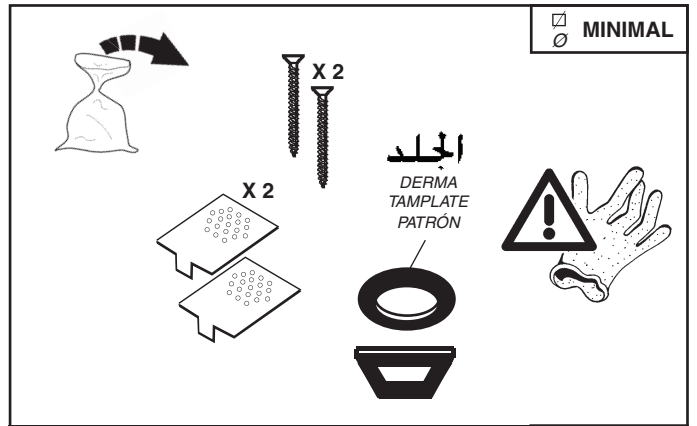
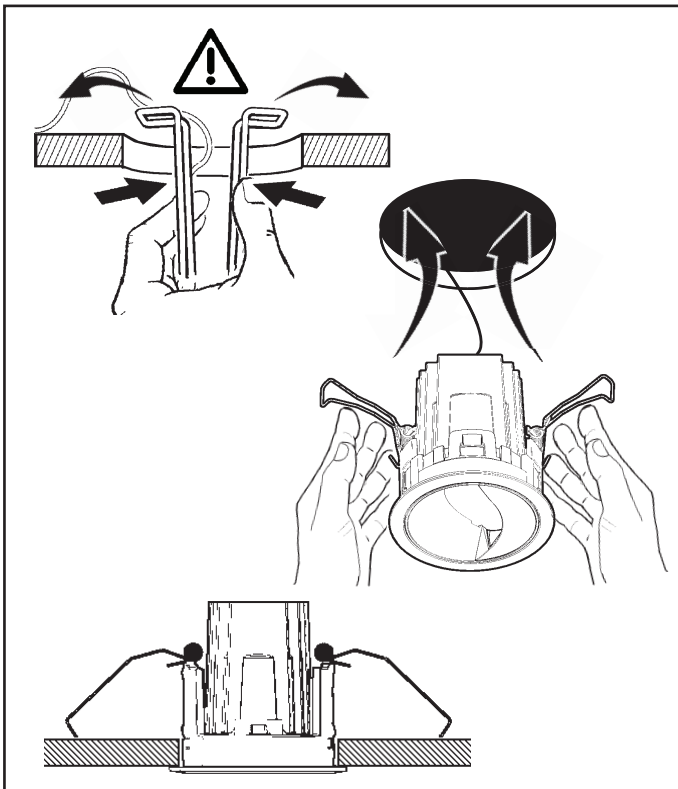
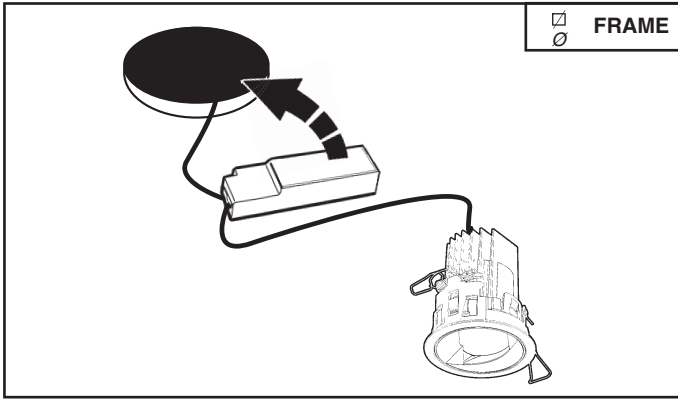
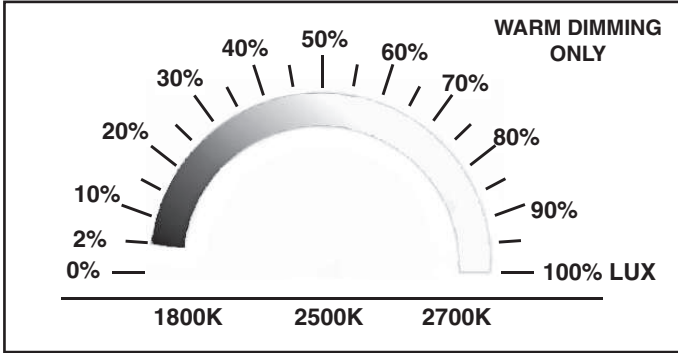

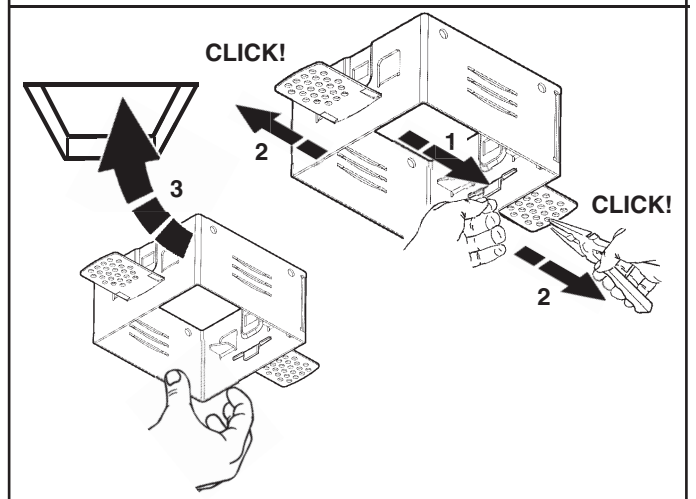
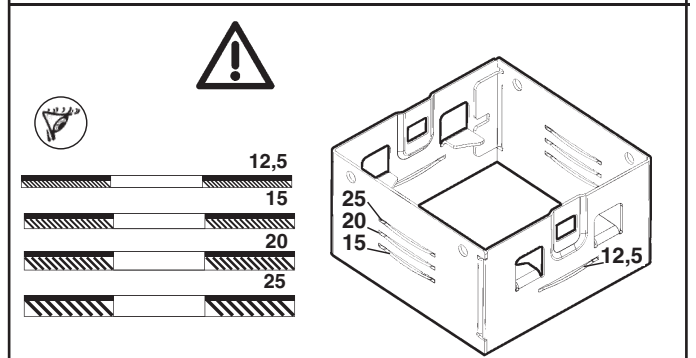
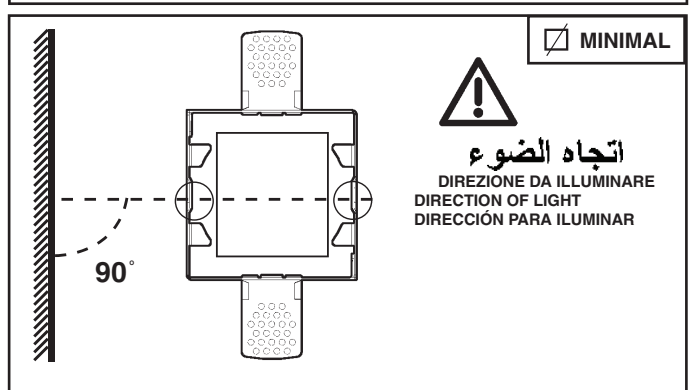
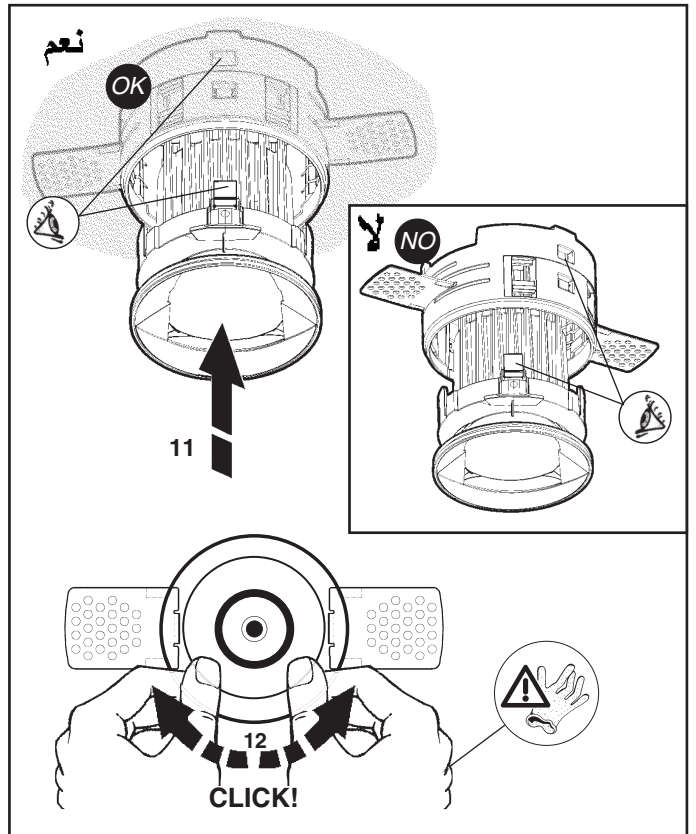
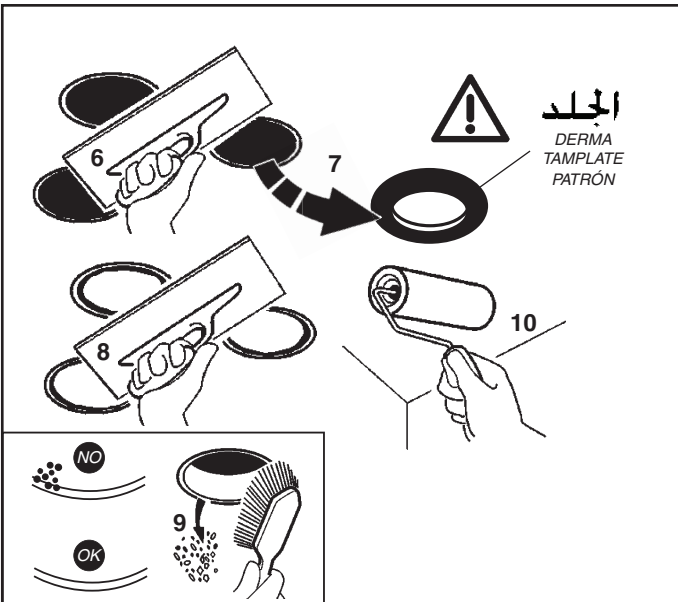
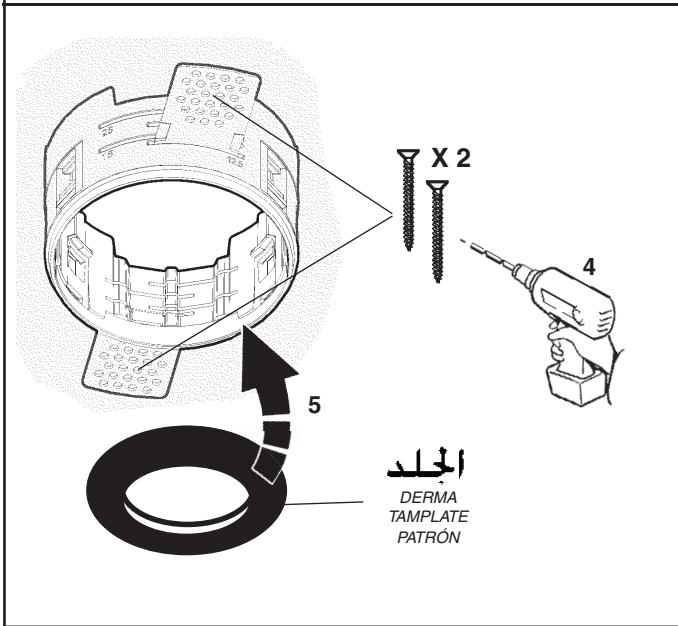
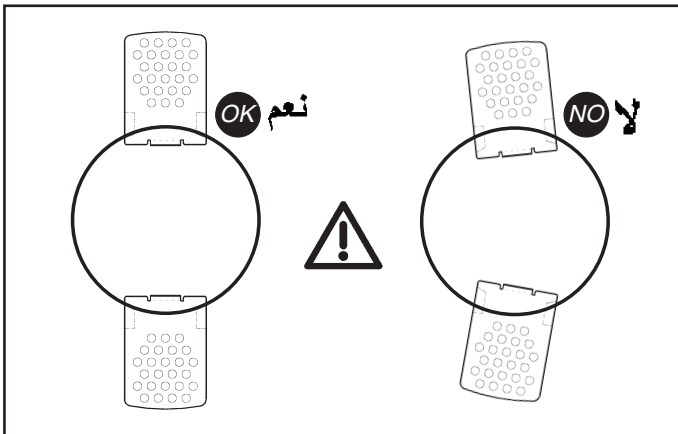

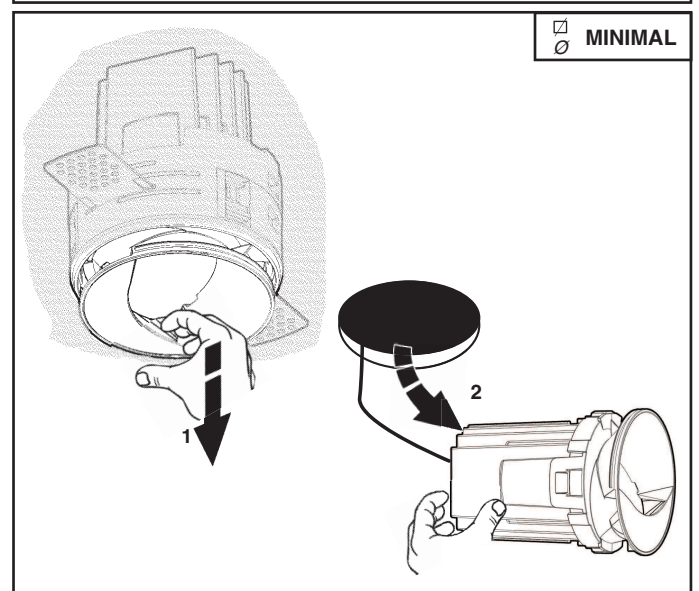
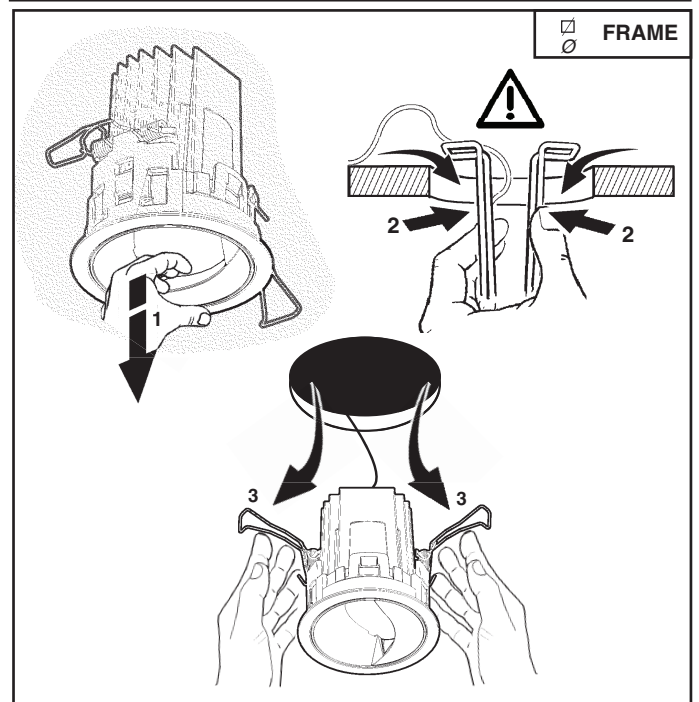
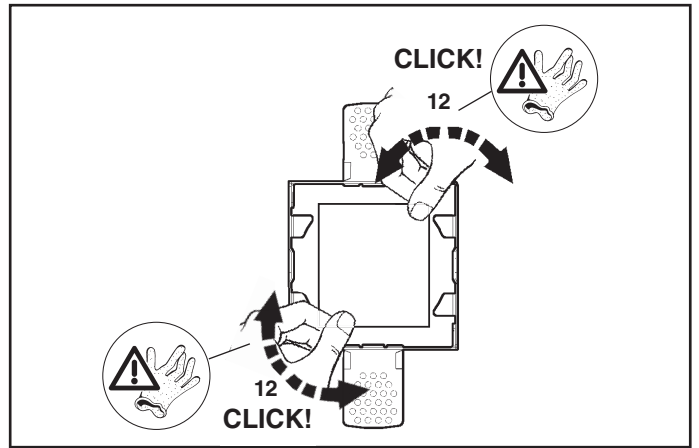
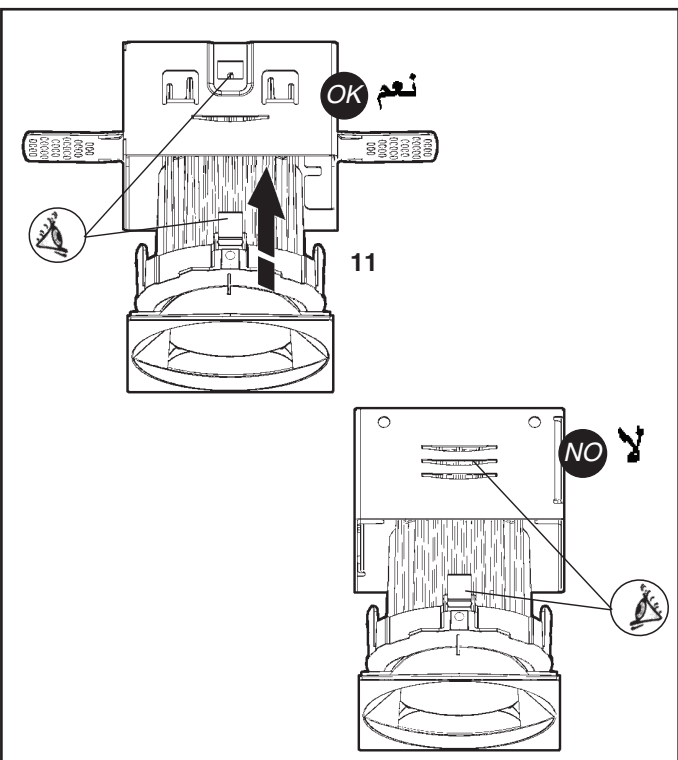
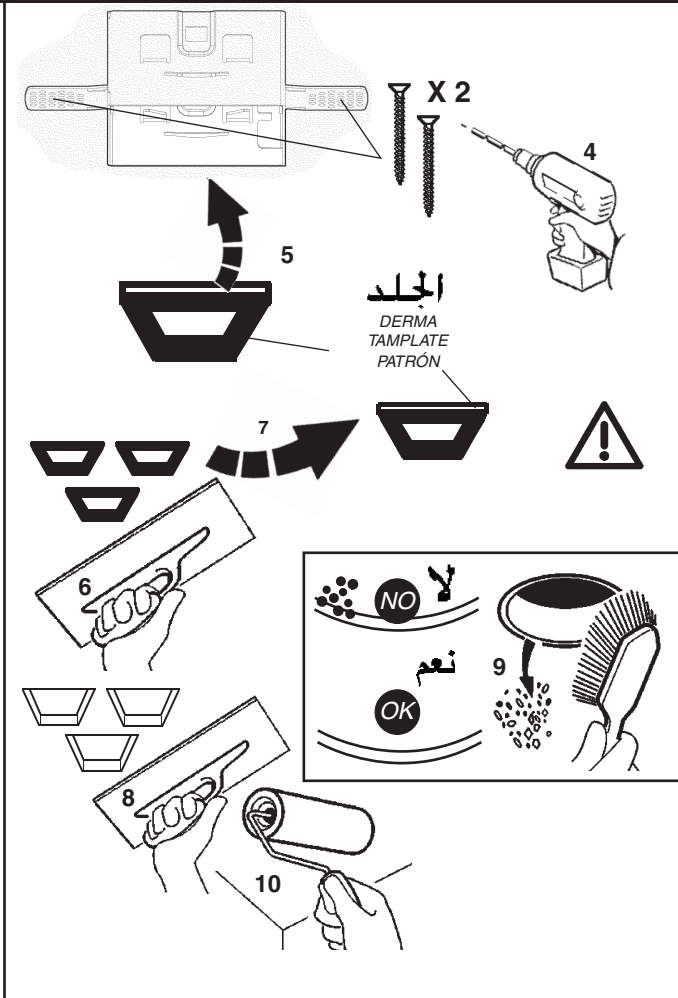
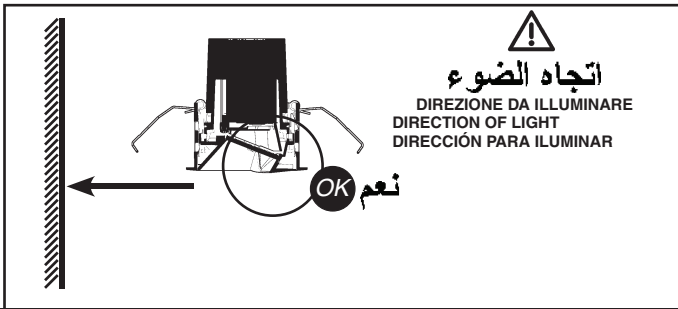



AR لا يمكن استخدام هذا المنتج في حالة وجود كسر في العدسات، ومن ثم يجب الاتصال بالشركة المصنعة لاستبدال العدسات المكسورة.

IT In caso di rottura delle lenti il prodotto non può essere utilizzato, contattare il costruttore per la sua sostituzione.

EN Should the lenses break, the product cannot be used. Contact the manufacturer for replacement.

ES En caso de rotura de las lentes, el producto no puede utilizarse y se debe contactar con el fabricante para su sustitución.

AR . **تنبيه: لاستبدال الضوء LED اتصل بشركة iGuzzini**

IT N.B.: Per la sostituzione del LED contattare l'azienda iGuzzini.

EN N.B.: For information on LED replacement please contact iGuzzini.

ES NOTA: Para sustituir el LED llame a la empresa iGuzzini.

AR انتبه: لاستخدام طقم الطوارئ نوع MY21 – MY36 والمطابقة مع المنتجات، يجب الالتزام بورقة تعليمات طقم الطوارئ.

IT ATTENZIONE: per l'utilizzo del kit emergenza art. MY21 – MY36 e le compatibilità con i prodotti, fare riferimento al foglio istruzioni del kit emergenza.

EN WARNING: see the emergency kit instruction sheet for how to use the art. MY21 – MY36 emergency kit and its product compatibility.

ES ATENCIÓN: para más información sobre el uso del kit de emergencia art. MY21 – MY36 y la compatibilidad con los productos, consultar la hoja de instrucciones del kit de emergencia.



FRAME

∅ 59mm + ART. MY21 / MY36 → A=60⁺²₋₀mm

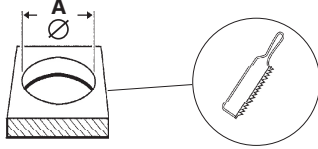

- I** Istruzioni per le operazioni di servizio per l'apparecchio di illuminazione
GB Instructions on luminaire service operations
F Instructions pour les opérations de service du luminaire
D Wartungsanleitung für die Leuchte
NL Instructies voor de onderhoudsoperaties op de verlichtingsarmatuur
E Instrucciones para las operaciones de servicio del aparato de alumbrado
DK Anvisninger i serviceindgreb på belysningsarmatur
N Anvisninger for betjening av lysapparatet
S Instruktioner för användning av belysningsanordningen
RUS Инструкции по эксплуатации осветительного прибора
CN 照明装置检修操作说明

Sostituire la lampada parzialmente esausta
 Replace the partly exhausted lamp
 Remplacer la lampe partiellement épuisée
 Die teilweise erschöpfte Lampe austauschen
 Vervang de gedeeltelijk lege lamp
 Sustituir la lámpara parzialmente agotada
 Udskift den delvist udtjente pære
 Skifte ut den delvis utbrente lyspæren
 Byt ut den delvis förbrukade lampan
 Замена частично отработанной лампочки
 更换部分老化的灯泡



Spegnimento
 Switch it off
 Extinction
 Ausschaltung
 Uitschakeling
 Apagado
 Slukning
 Slukking
 Släckning
 Выключение
 关灯

Interrompere l'alimentazione dell'apparecchio
 Cut the power supply to the luminaire
 Couper l'alimentation du luminaire
 Stromversorgung der Leuchte unterbrechen
 Onderbreek de voeding van het apparaat
 Interrumpir la alimentación del aparato
 Afbryd armaturets strømforsyning
 Avbryte strømtilførselen til apparatet
 Koppla från anordningens strömförsörjning
 Отключить электропитание прибора
 中断装置供电



Aprire l'apparecchio
 Open the fixture
 Ouvrir le luminaire
 Das Gerät öffnen
 Open het apparaat
 Abrir el aparato
 Åbn armaturet
 Åpne apparatet
 Öppna anordningen
 Раскрыть прибор
 打开装置

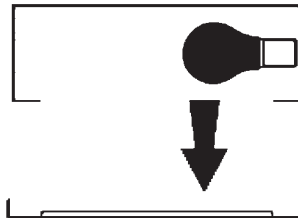

Rimuovere la lampada esausta
 Remove the exhausted lamp
 Retirer la lampe épuisée
 Die alte Lampe entnehmen
 Verwijder de lege lamp
 Quitar la lámpara agotada
 Tag den udtjente pære ud
 Fjerne den utbrente lyspæren
 Ta bort den förbrukade lampan
 Вынуть старую лампочку
 取出老化的灯泡

Portarla in un centro di riciclaggio
 Carry it to a recycling centre
 La porter dans une déchetterie pour son recyclage
 Ordnungsgemäß entsorgen
 Breng de lamp naar een recyclingcentrum
 Llevarla a un centro de reciclaje
 Aflever den på en genbrugsstation
 Lever den til en miljøstasjon
 Lämna in den till en återvinningsanläggning
 Сдать ее в пункт приема утильсырья
 将其送往回收中心



Inserire la nuova lampada
 Introduce the new lamp
 Installer la lampe neuve
 Die neue Lampe einsetzen
 Doe de nieuwe lamp op zijn plek
 Montar la nueva lámpara
 Sæt den nye pære i
 Sette i den nye pæren
 Sätt i den nya lampan
 Вставить новую лампочку
 装入新灯泡

Inserire la nuova lampada nel portalampana
 Fit the new lamp into the socket
 Installer la nouvelle lampe dans le support de lampe
 Die neue Lampe in den Sockel einsetzen
 Doe de nieuwe lamp in de lamphouder
 Montar la nueva lámpara en el portalampana
 Sæt den nye pære i fatningen
 Sette den nye pæren inn i lampeholderen
 Sätt i den nya lampan i lamphållaren
 Вставить новую лампочку в патрон
 将新灯泡插入灯泡架中



Riposizionare ottica
 Re-place the optic
 Remettre l'optique à sa place
 Die Optik wieder einsetzen
 Doe de optiek weer op zijn plaats
 Volver a montar la óptica
 Sæt den optiske enhed på plads
 Innstille linsen
 Flytta om optiken
 Отрегулировать линзы
 重新定位光头



Effettuare prova di funzionamento
 Perform operative test
 Procéder à un essai de fonctionnement
 Eine Funktionsprüfung durchführen
 Controleer de correcte werking
 Hacer una prueba de funcionamiento
 Afprøv funktionen
 Prøve om den fungerer
 Utför funktionstest
 Выполнить проверку исправности работы
 执行功能测试



I Istruzioni per la pulizia dell'apparecchio di illuminazione
GB Instructions on luminaire cleaning operations
F Instructions pour le nettoyage du luminaire
D Anweisungen zur Reinigung der Leuchte
NL Instructies voor de reiniging van de verlichtingsarmatuur
E Instrucciones para limpiar el aparato de alumbrado
DK Anvisninger i rengøring af belysningsarmaturet
N Anvisninger for rengjøring av lysapparatet
S Instruktioner för rengöring av belysningsanordningen
RUS Инструкции по чистке осветительного прибора
CN 照明装置清洁说明

Pulire l'apparecchio
Clean the fixture
Nettoyer le luminaire
Das Gerät reinigen
Reinig het apparaat
Limpiar el aparato
Rengør armaturet
Rengjøre apparatet
Rengör anordningen
Чистка прибора
清洁装置



Spegnimento
Switch it off
Extinction
Ausschaltung
Uitschakeling
Apagado
Slukning
Slukking
Släckning
Выключение
关灯

Interrompere l'alimentazione dell'apparecchio
Cut the power supply to the luminaire
Couper l'alimentation du luminaire
Stromversorgung der Leuchte unterbrechen
Onderbreek de voeding van het apparaat
Interrumpir la alimentación del aparato
Afbryd armaturets strømforsyning
Avbryt strømtilførselen til apparatet
Koppla från anordningens strömförsörjning
Отключить электропитание прибора
中断装置供电



Spolverare l'ottica esterna
Remove dust from the external optic
Dépoussiérer l'optique extérieure
Die externe Optik abstauben
Stof de externe optiek af
Quitar el polvo de la óptica exterior
Tør støvet af den udvendige optiske enhed
Fjerne støv fra den eksterne lysenheden
Damma av den yttre optiken
Вытереть пыль с внешней стороны линз
为外侧光头掸尘



Lavare l'ottica esterna
Wash the external optic
Laver l'optique extérieure
Die externe Optik waschen
Was de externe optiek
Lavar la óptica exterior
Vask den udvendige optiske enhed
Vaske den eksterne lysenheden
Rengör den yttre optiken
Вымыть линзы с внешней стороны
清洁外光头



Rimuovere l'ottica
Remove the optic
Retirer l'optique
Die Optik abnehmen
Verwijder de optiek
Quitar la óptica
Tag den optiske enhed af
Fjerne lysenheden
Ta bort optiken
Снять линзы
取下光头

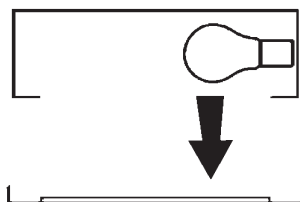

Pulire la parte interna dell'apparecchio di illuminazione
Clean the inside of the fixture
Nettoyer l'intérieur du luminaire
Die Innenseite der Leuchte reinigen
Reinig de binnenzijde van de verlichtingsarmatuur
Limpiar el interior del aparato de alumbrado
Rengør belysningsarmaturets indvendige dele
Rengjøre lysapparatet innvendig
Rengör belysningsanordningen invändigt
Протереть осветительный прибор изнутри
清洁照明装置内部



Riposizionare ottica
Re-place the optic
Remettre l'optique à sa place
Die Optik wieder einsetzen
Doe de optiek weer op zijn plaats
Volver a montar la óptica
Sæt den optiske enhed på plads
Innstille linsen
Flytta om optiken
Отрегулировать линзы
重新定位光头



Effettuare prova di funzionamento
Perform operative test
Procéder à un essai de fonctionnement
Eine Funktionsprüfung durchführen
Controleer de correcte werking
Hacer una prueba de funcionamiento
Afprøv funktionen
Prøve om den fungerer
Utför funktionstest
Выполнить проверку исправности работы
执行功能测试

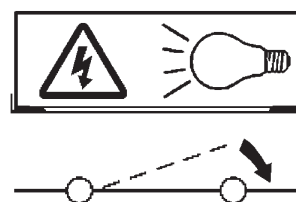

- I** Istruzioni per il fine vita e lo smaltimento dei componenti
GB Instructions on end-of-life and component disposal
F Instructions pour la gestion des composants en fin de vie et leur mise au rebut
D Anweisungen zur Entsorgung der Leuchtenkomponenten
NL Instructies voor het verwijderen van de armatuur en het recyclen van de onderdelen
E Instrucciones para el final de vida y la eliminación los componentes
DK Anvisninger i udtjent armatur og bortskaffelse af komponenter
N Anvisninger for endt levetid og avfallsbehandling av delene
S Instruktioner vid bortskaffning och kassering av komponenter
RUS Инструкции по утилизации прибора и его комплектующих по окончании его срока службы
CN 寿命期结束与零件废弃处置说明

<p>Spegnimento Switch it off Extinction Ausschaltung Uitschakeling Apagado Slukning Slukking Släckning Выключение 关灯</p> <p>Interrompere l'alimentazione dell'apparecchio Cut the power supply to the luminaire Couper l'alimentation du luminaire Stromversorgung der Leuchte unterbrechen Onderbreek de voeding van het apparaat Interrompirla alimentación del aparato Afbryd armaturets strømforsyning Avbryt strømtilførselen til apparatet Koppla från anordningens strömförsörjning Отключить электропитание прибора 中断装置供电</p> 	<p>Rimuovere la/e lampada/e per la dismissione Remove the lamp(s) for decommissioning Retirer la(les) lampe(s) pour sa(leur) mise au rebut Die Lampe/n ordnungsgemäß entsorgen Verwijder de lamp(en) voor het recyclen Quitar la(s) lámpara(s) para el desecho Tag pæren/pærerne ud til bortskaffelse Fjerne lampen/-e som skal kastes Ta bort lampan/-orna för bortskaffningen Вынуть лампочку/и для утилизации прибора 取出需要丢弃的灯泡</p> 	<p>Rimuovere la batteria per la dismissione Remove the battery for decommissioning Retirer la batterie pour sa mise au rebut Die Batterie ordnungsgemäß entsorgen Verwijder de batterij voor het recyclen Quitar la batería para el desecho Tag batteriet ud til bortskaffelse Fjerne batteriet som skal kastes Ta bort batteriet för bortskaffningen Вынуть батарейку для утилизации прибора 取出需要丢弃的电池</p> 	<p>Rimuovere l'apparecchio per la dismissione Remove the fixture for decommissioning Enlever le luminaire pour sa mise au rebut Das Gerät ordnungsgemäß entsorgen Verwijder het apparaat voor het recyclen Quitar el aparato para el desecho Tag armaturet ud til bortskaffelse Fjerne apparatet som skal kastes Ta bort anordningen för bortskaffningen Снять прибор для утилизации 取出需要丢弃的装置</p> 
-----------------------------------------------------------------------------------------------------------------------------------------------------------------------------------------------------------------------------------------------------------------------------------------------------------------------------------------------------------------------------------------------------------------------------------------------------------------------------------------------------------------------------------------------------------------------------------------------------------------------------------------------------------------------------------------------------------	------------------------------------------------------------------------------------------------------------------------------------------------------------------------------------------------------------------------------------------------------------------------------------------------------------------------------------------------------------------------------------------------------------------------------------------------------------------------------------------------------------------------------------------------------------------	----------------------------------------------------------------------------------------------------------------------------------------------------------------------------------------------------------------------------------------------------------------------------------------------------------------------------------------------------------------------------------------------------------------------------------------------------------------------------------------------------------------------------------------	--------------------------------------------------------------------------------------------------------------------------------------------------------------------------------------------------------------------------------------------------------------------------------------------------------------------------------------------------------------------------------------------------------------------------------------------------------------------------------------------------------------------------------

<p>Inviare i materiali ad un centro di raccolta RAEE Send the materials to a WEEE collection centre Envoyer les matériaux dans une déchetterie DEEE Die Materialien in einem WEEE-Zentrum entsorgen Zend de materialen naar een recyclingscentrum voor de AEEA Enviar los materiales a un centro de recogida RAEE Afløver materialerne på et indsamlingscenter for elektronisk udstyr Sende materialene til en miljøstasjon for resirkulering av EE-avfall Skicka materialet till en RAEE uppsamlingscentral Сдать материалы в пункт приема утильсырья 将材料送往电气和电子垃圾回收中心</p> 			
--------------------------------------------------------------------------------------------------------------------------------------------------------------------------------------------------------------------------------------------------------------------------------------------------------------------------------------------------------------------------------------------------------------------------------------------------------------------------------------------------------------------------------------------------------------------------------------------------------------------------------------------------------------------------------------------------------------------	--	--	--