

## LEDSTRIP 50W (underscore6)

### ATTENZIONE:

LA SICUREZZA DELL'APPARECCHIO E' GARANTITA SOLO CON L'USO APPROPRIATO DELLE SEGUENTI ISTRUZIONI; PERTANTO E' NECESSARIO CONSERVARLE.

### WARNING:

THE SAFETY OF THIS FIXTURE IS GUARANTEED ONLY IF YOU COMPLY WITH THESE INSTRUCTIONS; REMEMBER TO CONSERVE IN A SAFE PLACE.

### ATTENTION:

LA SECURITE DE L'APPAREIL N'EST GARANTIE QU'EN CAS D'UTILISATION CORRECTE DES INSTRUCTIONS SUIVANTES; IL FAUT PAR CONSEQUENT LES CONSERVER.

### ACHTUNG:

DIE SICHERHEIT DES GERÄTES WIRD NUR DURCH SACHGEMÄSSE BEFOLGUNG NACHSTEHENDER ANWEISUNGEN GEWÄHRLEISTET; IHRE AUFBEWAHRUNG IST DESHALB SEHR WICHTIG.

### OPGELET:

DE VEILIGHEID VAN DI ATOESTEL IS SLECHTS DAN GEGARANDEERD ALS INDIEN DE VOLGENDE INSTRUCTIES STRIKT WORDEN TOEGEPAST: DAAROM MOET MEN ZE OOK BEWAAREN.

### ATENCION:

LA SEGURIDAD DEL APARATO SE GARANTIZA SOLO CUMPLIENDO CUIDADOSAMENTE LAS SIGUIENTES INSTRUCCIONES; POR ELLO, ES NECESARIO CONSERVARLAS.

### BEMÆRK:

SIKKERHEDEN VED BRUG AF ARMATURET KAN KUN GARANTERES, HVIS DISSE ANVISNINGER FØLGES; SØRG DERFOR FOR AT GEMME DEM.

### ADVARSEL:

SIKKERHETEN TIL DETTE APPARATET GARANTERES KUN HVIS DU OVERHOLDER DISSE INSTRUKSJONENE; HUSK Å OPPBEVARE DEM PÅ ET TRYGT STED.

### OBSERVERA!

UTRUSTNINGENS SÄKERHET KAN ENDAST GARANTERAS OM DESSA ANVISNINGAR RESPEKTERAS I DETALJ. SPARA DÄRFÖR DESSA ANVISNINGAR FÖR FRAMTIDA KONSULTATION.

### ВНИМАНИЕ:

МЫ ГАРАНТИРУЕМ БЕЗОПАСНУЮ ЭКСПЛУАТАЦИЮ ИЗДЕЛИЯ ТОЛЬКО ПРИ СОБЛЮЖДЕНИИ СЛЕДУЮЩИХ ИНСТРУКЦИЙ; С ЭТОЙ ЦЕЛЬЮ НЕОБХОДИМО СОХРАНИТЬ ДАННУЮ БРОШЮРУ.

### 警告:

为确保该装置安全，请遵守操作指示；并于安全场所放置。

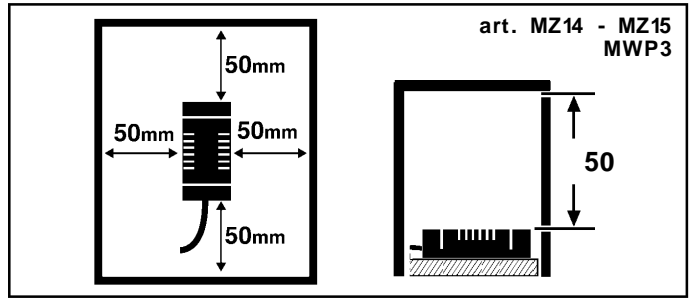
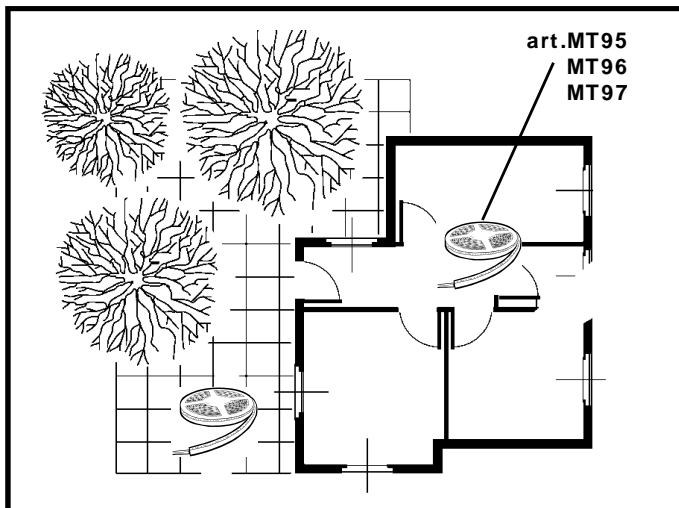
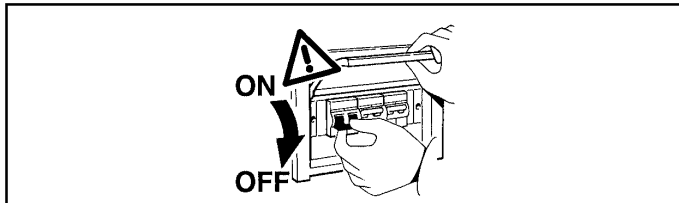

I Maneggiare con cura e non sottoporre a tensioni meccaniche.

GB Handle with care and do not subject to mechanical stress.

F Manipuler avec précaution et ne pas soumettre à des contraintes mécaniques

D Vorsichtig behandeln und keinen mechanischen Spannungen aussetzen

NL Voorzichtig bij het gebruik van dit product. Mag niet worden onderworpen aan mechanische spanning

E Manejar con cuidado y no someter a tensiones mecánicas

DK Håndter med forsigtighed og udsæt ikke for mekaniske spændinger

N Må behandles forsiktig. Må ikke utsettes for mekaniske spenninger.

S Ska hanteras försiktigt och inte utsättas för mekaniska påfrestningar

RU Обращаться осторожно и не подвергать механическому напряжению

CN 小心轻放，切勿使其遭受机械应力

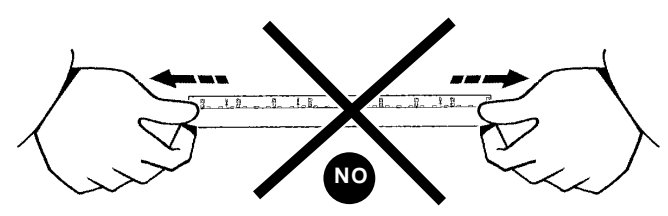
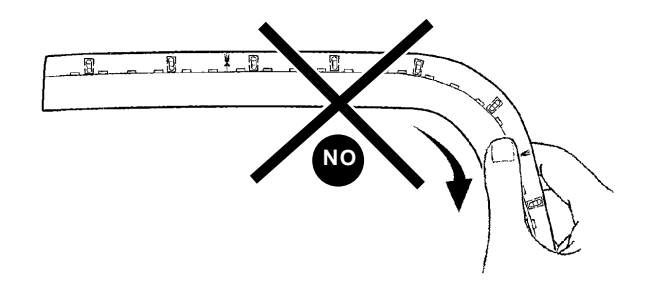
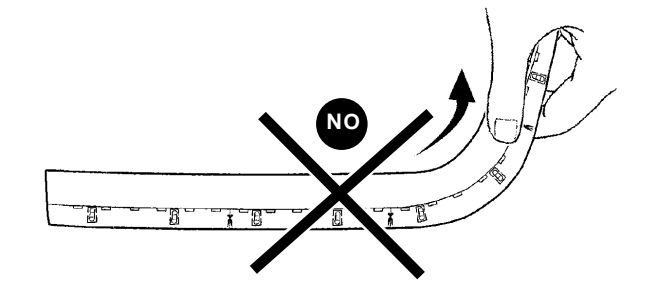
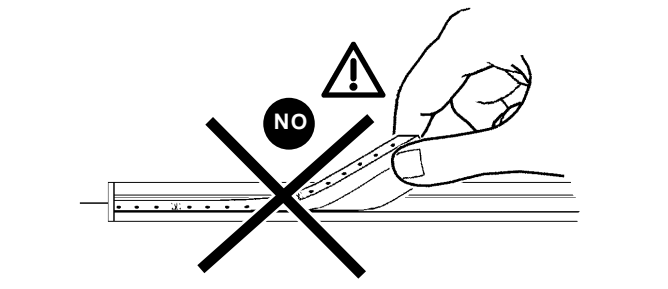
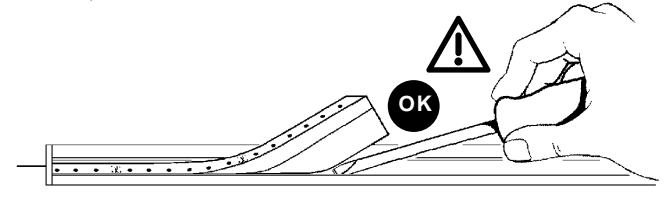

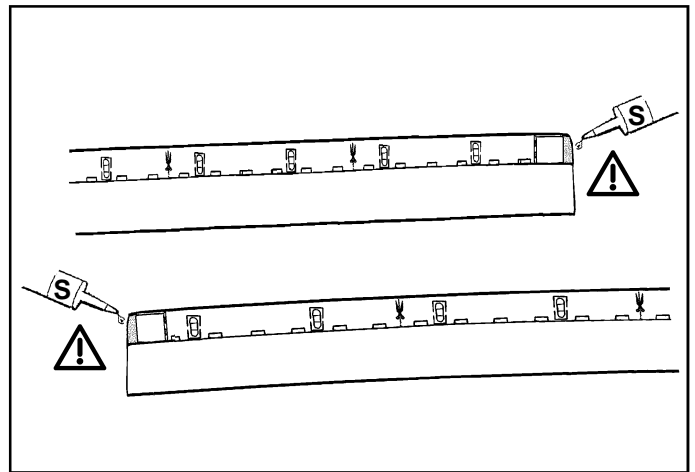
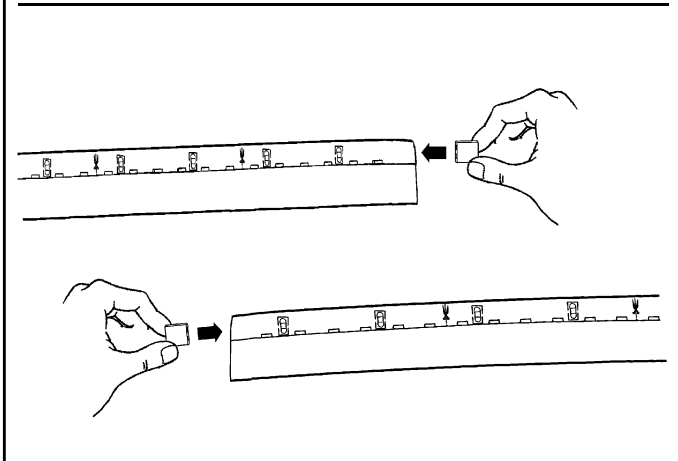
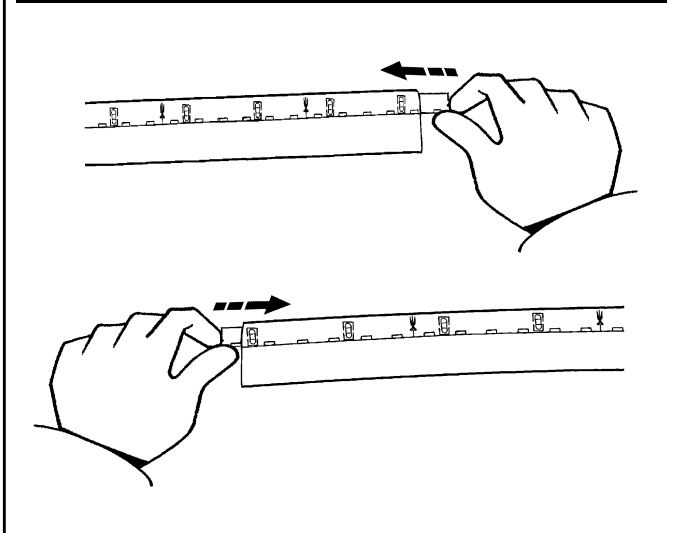
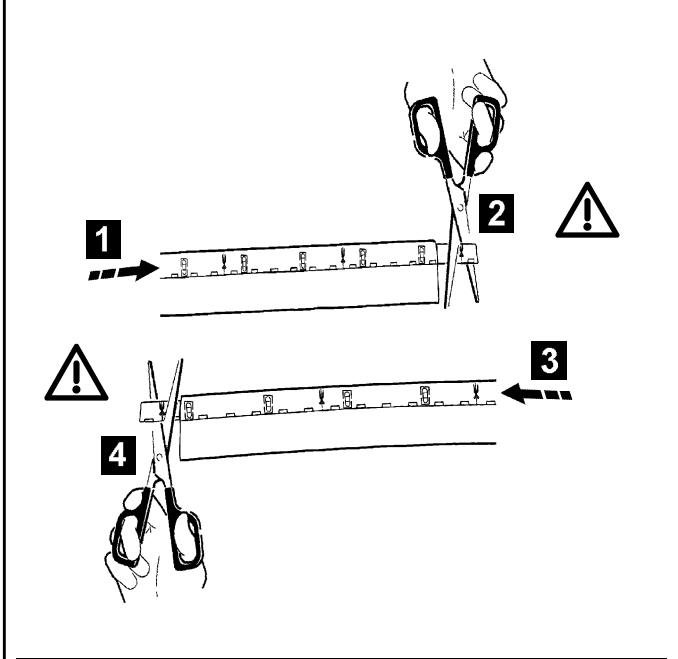
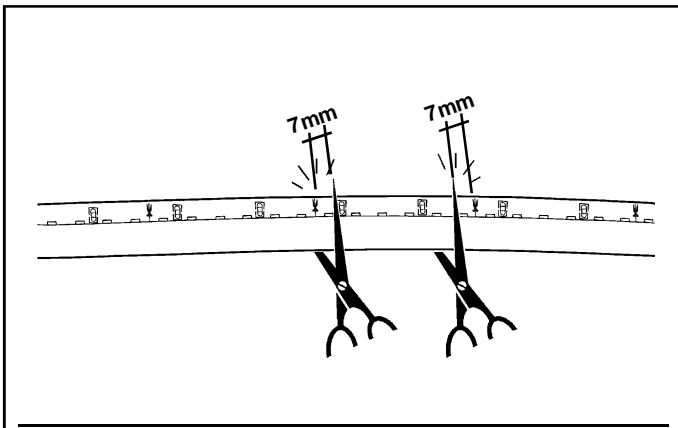

- I **N.B.:** Il grado di protezione del sistema, è garantito soltanto se si effettua correttamente l'operazione di siliconatura (S) con silicone fornito dalla iGuzzini.
- GB **N.B.:** The degree of protection offered by the system is only guaranteed if the siliconisation procedure is performed correctly (S) using silicone supplied by iGuzzini.
- F **N.B.:** L'indice de protection du système n'est assuré que si l'application de silicone a été effectuée correctement (S) et que le silicone a été fourni par iGuzzini.
- D **N.B.:** Der Schutzgrad des Systems ist nur gewährleistet, wenn die Abdichtung mit dem von iGuzzini gelieferten Silikon korrekt ausgeführt wird (S).
- NL **N.B.:** De beschermingsgraad van het systeem is alleen dan gegarandeerd als het silicone, dat door iGuzzini wordt geleverd, goed is aangebracht (S).
- E **N.B.:** El grado de protección del sistema está garantizado sólo si se realiza correctamente la operación de siliconado (S) con silicona suministrada por iGuzzini.
- DK **N.B.:** Beskyttelsesgraden på systemet kan kun garanteres, hvis der påføres silikone (S) på korrekt vis med silikone leveret af iGuzzini.
- N **N.B.:** Graden av beskyttelse som tilbys av systemet garanteres kun hvis silikonet, som leveres av iGuzzini, blir påført korrekt (S).
- S **OBS!** Systemets skyddsgrad garanteras endast om silikoniseringsproceduren utförs på ett korrekt sätt med silikon från iGuzzini (S).
- RUS **ПРИМЕЧАНИЕ:** Класс электробезопасности системы гарантируется, только если будет правильно выполнена пропитка силиконом (S) поставляемым iGuzzini.
- CN **注意事项:** 只有在正确地施行了聚硅酮操作之后系统保护的等级才被保证 (S)。

	<b>MAX mt</b>
<b>ART</b>	ALIMENTATORE BALLAST BALLAST VORSCHALTGERÄT VOORSCHAKELAPPARAAT ALIMENTADOR STRØMFORSYNINGSENHED BALLAST STRÖMFÖRSÖRJNINGSANORDNING БЛОК ПИТАНИЯ 电源
	<b>MZ14 - MZ15</b>
<b>MT95</b> <b>MT96</b> <b>MT97</b>	<b>8</b>

- I E' possibile collegare in serie fino a 5m di Led Strip accettando delle differenze di luminosità sulla linea
- GB The in-series connection of LED strips is possible up to 5m allowing for any differences in luminosity on the line.
- F Il est possible de brancher en série jusqu'à 5 mètres de "Led Strip" sous réserve d'accepter des différences de luminosité sur la ligne.
- D Es können bis zu 5m "LED Strip" in Serie geschaltet werden, wobei jedoch unterschiedliche Helligkeiten entlang der Linie entstehen.
- NL Het is mogelijk tot aan 5 m "Led Strips" op dezelfde serie aan te sluiten als u verschillen van lichtintensiteit op de lijn kunt accepteren.
- E Se puede conectar en serie hasta 5m de "Led Strip" aceptando diferencias de luminosidad en la línea.
- DK Man kan serieforbinde op til 5 m "Led Strip", hvilket vil medføre forskelle i lysstyrken på linjen.
- N Det er mulig å koble opptil 5 m "Led Strip" i serie ved å godta lysforskjeller på linjen.
- S Det går att serieansluta upp till 5 m "Led Strip" genom att acceptera ljuskillnaderna på linjen.
- RUS Можно последовательно подсоединить вплотью до 5 м "Led Strip", допуская разницу в освещении на линии.
- CN LED 灯条串联连接可达 5 米, 并且线路上的灯可以呈现不同的亮度。

ART	Ampere/m [A]
MT95 MT96 MT97	0.45

**$L = \frac{25 \times S}{A \times m}$**

S = Sezione cavo in Rame [mm ^2]  
A = Ampere/m  
m = Metri totali collegati alla Linea

S= Copper cable section [mm ^2]  
A= Ampere/m  
m= Total metres connected to the line

S= Section du câble en cuivre [mm ^2]  
A= Ampères/m  
m= Total des mètres raccordés à la ligne

S= Durchmesser Kupferkabel [mm ^2]  
A= Ampere/m  
m= Summe der an die Linie angeschlossenen Meter

S= Sectie koperen kabel [mm ^2]  
A= Ampere/m  
m= totaal aangesloten Meters op de Lijn

S= Sección cable de cobre [mm ^2]  
A= Ampere/m  
m= Metros totales conectados a la línea

S= Tværsnit kobberkabel [mm ^2]  
A= Ampere/m  
m= Meter i alt tilsluttet linjen

S= Kabeltværsnitt i kobber [mm ^2]  
A= Ampere/m  
m= Meter totalt tilkoblet til linjen

S= Kopparkabelns tværsnitt [mm ^2]  
A= Ampere/m  
m= Totalt antal meter anslutna till linjen

S= Сечение медного провода [мм ^2]  
A= Ампер/м  
m= Всего метров, подсоединенных к Линии

S= 铜电缆截面 [平方毫米]  
A= 安培/米  
m= 连接到线路上的总长度 (按米计算)

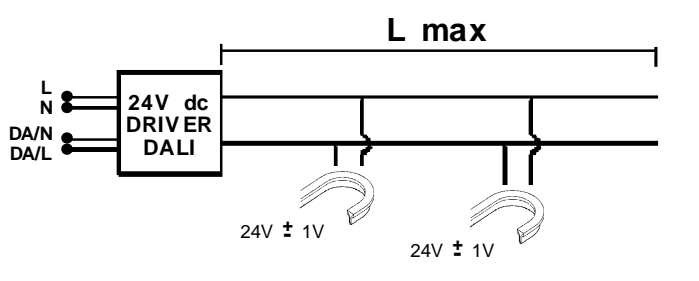
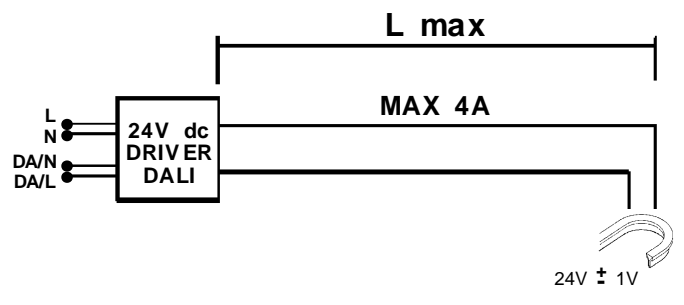
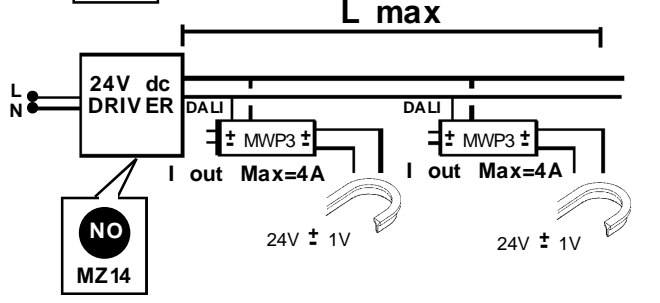
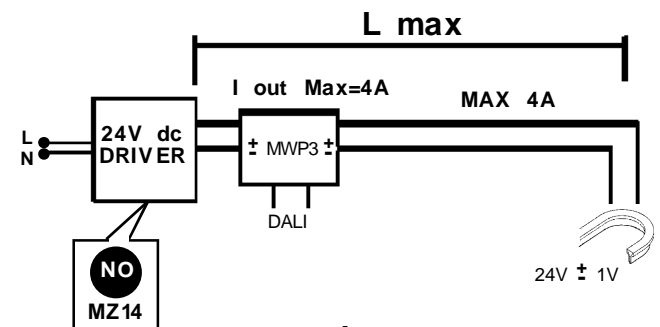
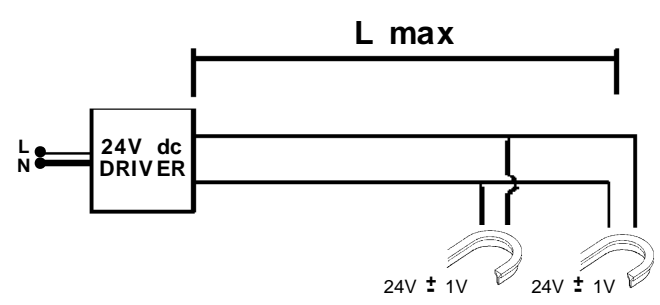
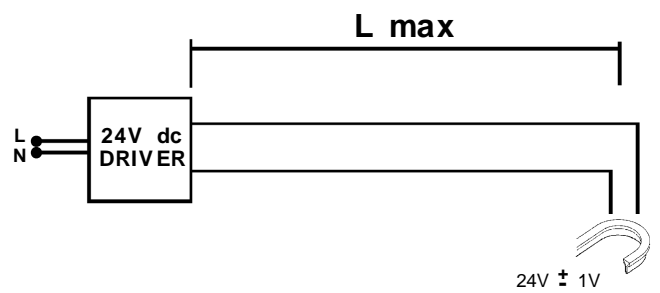

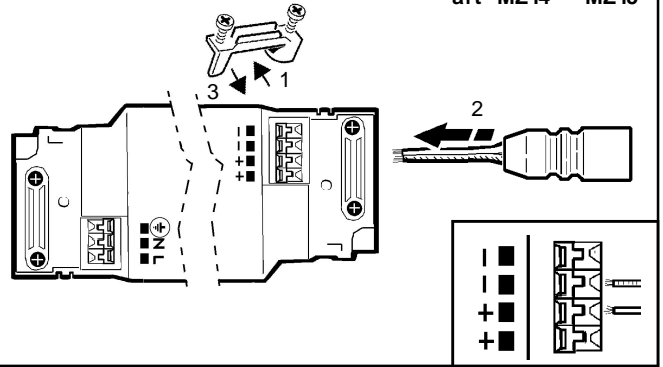
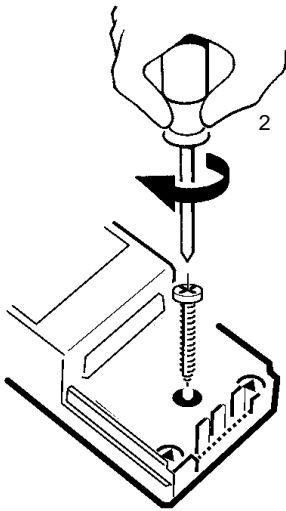
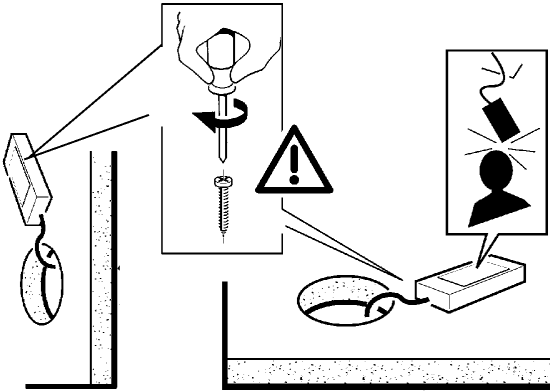

I Le prestazioni e la sicurezza dell'apparecchio sono garantite soltanto per oscillazioni della corrente del  $\pm 5\%$  rispetto al valore nominale.

La conformità alla norma è garantita soltanto utilizzando alimentatori iGuzzini (art.: MZ14 - MZ15) od equivalenti di tipo SELV che rispondano alle vigenti norme

GB The performance level and safety of the lighting fixture are only guaranteed for oscillations of  $\pm 5\%$  in the current, in relation to the nominal value.

Conformity with the standard is guaranteed only if either iGuzzini ballasts (item code MZ14 - MZ15) or equivalent SELV type ballasts which comply with current regulations are used.

F Les performances et la sécurité de l'appareil ne sont assurées que pour des oscillations de courant de  $\pm 5\%$  par rapport à la valeur nominale.

La conformité à la norme n'est assurée qu'en cas d'utilisation de ballasts iGuzzini (réf. : MZ14 - MZ15) ou équivalents type SELV conformes aux normes.

D Die Leistungen und die Sicherheit des Geräts sind nur für vom Vorschaltgerät abgehende Spannungsschwankungen von  $\pm 5\%$  in Bezug auf den Nennwert gewährleistet.

Die Übereinstimmung mit den Vorschriften ist nur bei Verwendung von iGuzzini-Netzteilen (Art.: MZ14 - MZ15) oder gleichwertigen des Typs SELV, die den gültigen Bestimmungen entsprechen, gewährleistet.

NL De prestaties en de veiligheid van het apparaat zijn alleen gegarandeerd voor spanningsvariaties van  $\pm 5\%$  ten opzichte van de nominale waarde.

De conformiteit aan de norm wordt alleen gegarandeerd als u iGuzzini voorschakelapparaten gebruikt (art.: MZ14 - MZ15) of overeenkomstige, van het type SELV, die aan de geldende normen voldoen.

E Las prestaciones y la seguridad del aparato están garantizada solamente con oscilaciones de la corriente del  $\pm 5\%$  respecto al valor nominal.

La conformidad a la norma se garantiza solamente con el uso de alimentadores iGuzzini (art. MZ14 - MZ15) o equivalentes de tipo SELV que cumplen las normas vigentes.

DK Armaturets ydelse og sikkerhed kan kun garanteres ved strømsvingning på  $\pm 5\%$  i forhold til den nominelle værdi.

Opfyldelse af reglerne garanteres kun ved brug af strømforsyningsenheder fra iGuzzini (art.: MZ14 - MZ15) eller tilsvarende af typen SELV, der opfylder kravene i standarderne.

N Ytelsesnivået og sikkerheten til lysarmaturen kan kun garanteres for svingninger på  $\pm 5\%$  i strømmen, i forhold til nominell verdi.

Samsvar med forskriften garanteres bare ved bruk av transformatorer fra iGuzzini (art.: MZ14 - MZ15) eller tilsvarende av typen SELV som tilsvarer gjeldende forskrifter.

S Utrustningens prestanda och säkerhet garanteras endast vid en strömoscillation på  $\pm 5\%$  i förhållande till nominellt värde.

Överensstämmelse med standard garanteras endast genom att använda nättaggregat av typ iGuzzini (art.: MZ14 - MZ15) eller motsvarande av typ SELV som överensstämmer med gällande standard.

RUS Соответствие нормативу гарантируется только при использовании блоков питания iGuzzini (art.: MZ14 - MZ15 ) или аналогичных типа SELV, отвечающих действующим нормативам.

CN 只有在使用iGuzzini的供电( MZ14 - MZ15 产品)或者与之相同的SELV种类的符合法规的 供电情况下, 产品的合格性才能够被保证。

DALI

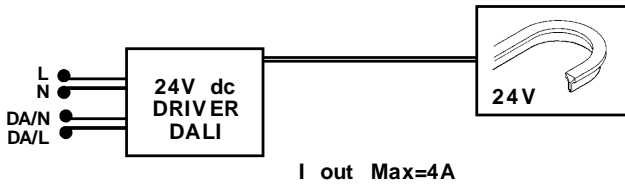

TOUCH DIM

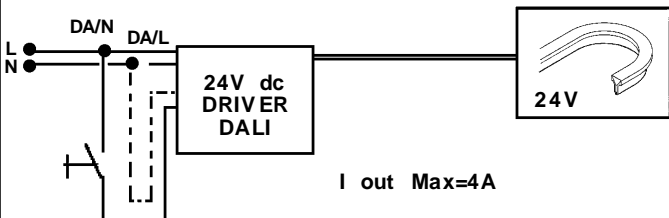

ACCESSORI PROFILI  
 PROFILES ACCESSORIES  
 ACCESSOIRES PROFILS  
 ZUBEHOER PROFILE  
 PROFIEL ONDERDELEN  
 ACCESORIOS PERFILES

TILBEHØR PROFILER  
 TILBEHØR PROFILER  
 ACCESSOARER PROFILER  
 Аксессуары профилей  
 配件配置文件

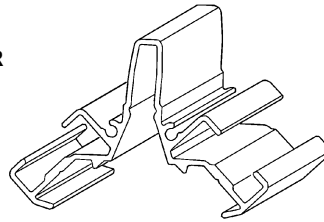

- I Morsetti non inclusa. L'installazione può richiedere l'intervento di personale qualificato.**  
 Caratteristiche tecniche della morsetti:  
 - n° 2 morsetti del tipo a vite (sezione max. 1 mm<sup>2</sup>)  
 - tensione di alimentazione 24V - 6A  
 - spellatura cavi di 8 mm.
- GB Terminal board not included. The aid of qualified personnel may be required for installation.**  
 Technical features of the terminal board:  
 - 2 terminals with a screw base (max. cross-section 1 mm<sup>2</sup>)  
 - 24 V - 6 A supply voltage  
 - 8 mm cable stripping length
- F Bornier non inclus. L'installation pourrait exiger l'intervention de personnel qualifié.**  
 Caractéristiques techniques du bornier:  
 - 2 bornes à vis (section maxi 1 mm<sup>2</sup>)  
 - tension d'alimentation 24V - 6A  
 - dénudage des câbles de 8 mm.
- D Klemmenleiste nicht enthalten. Die Installation muss gegebenenfalls von Fachkräften durchgeführt werden.**  
 Technische Merkmale der Klemmenleiste:  
 - 2 Schraubklemmen (Querschnitt max. 1 mm<sup>2</sup>)  
 - Versorgungsspannung 24V - 6A  
 - Kabelabisolierung 8 mm
- NL Klemmenstrook niet inbegrepen. De installatie kan de hulp van gekwalificeerde installateurs vereisen.**  
 Technische eigenschappen van de klemmenstrook:  
 - 2 klemmen van het schroeftype (max. diameter 1 mm<sup>2</sup>)  
 - voedingsspanning 24V - 6A  
 - strippen kabels 8 mm.
- E Clema de conexiones no incluida. La instalación puede necesitar la intervención de personal calificado.**  
 Características técnicas de la clema de conexiones:  
 - n. 2 terminales de tornillo (sección máx. 1 mm<sup>2</sup>)  
 - tensión de alimentación 24V - 6A  
 - peladura cables de 8 mm.

- DK Klemkasse følger ikke med. Installation kan kræve hjælp fra en elektriker.**  
 Klemkassens tekniske karakteristika:  
 - 2 klemmer af skruetypen (maks. snit 1 mm<sup>2</sup>)  
 - forsyningspænding 24V - 6A  
 - skrælning af ledninger 8 mm.
- N Klembrett ikke inkludert. Installasjonen kan kreve inngrep av kvalifisert personale.**  
 Klembrettets tekniske egenskaper:  
 - n° 2 klemkruer av typen med skrue (maksimalt tverrsnitt 1 mm<sup>2</sup>)  
 - matespenning på 24V - 6A.  
 - kabelfjerning på 8 mm.
- S Kopplingsplint ingår inte. Installationen kan kräva ingrepp från en utbildad fackman.**  
 Kopplingsplintens tekniska egenskaper:  
 - 2 st. skruvklämmor (max. tvärsnitt 1 mm<sup>2</sup>).  
 - Matningsspänning 24V - 6A.  
 - Kabelavskalning 8 mm.
- RUS Без клеммной колодки. Для монтажа может потребоваться вызвать квалифицированного электрика. Технические характеристики клеммной колодки:**  
 - 2 шт. винтовых клеммы (макс. сечение 1 мм<sup>2</sup>)  
 - напряжение электропитания 24 В - 6А  
 - оголение проводов на 8 мм.
- CN 不包括镇流器。安装设备时也可以请专业人员参与。**  
 镇流器的技术特点:  
 - 2个螺丝接头(最大截面1平方毫米)  
 - 电源电压 24 伏特 - 6安培  
 - 8 毫米脱皮电线。

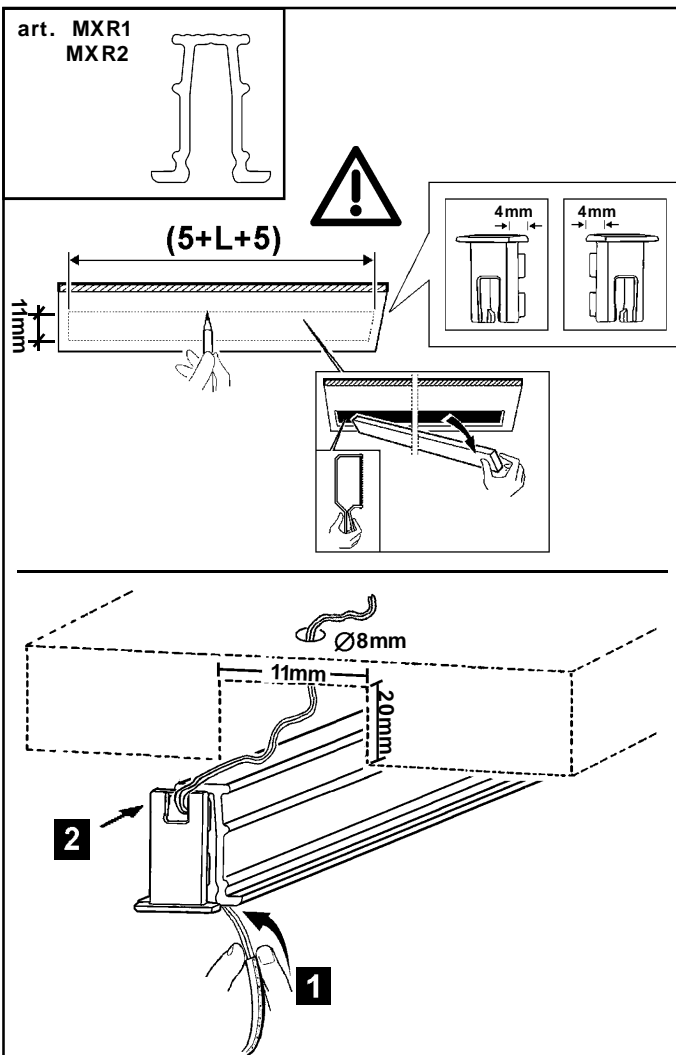

5

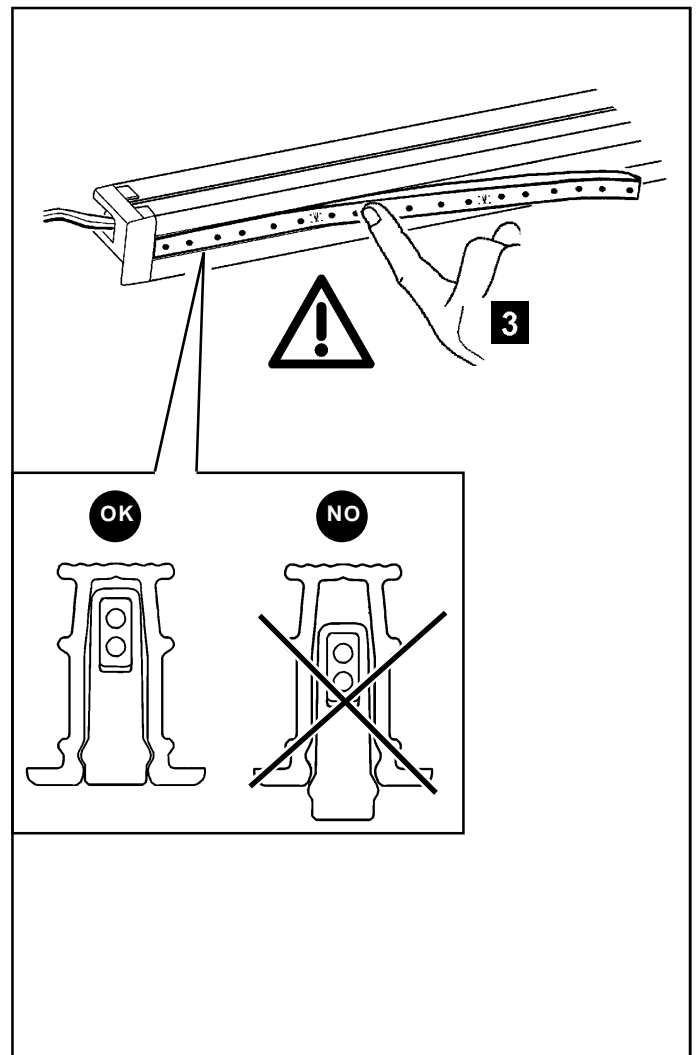

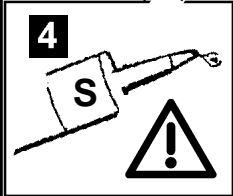
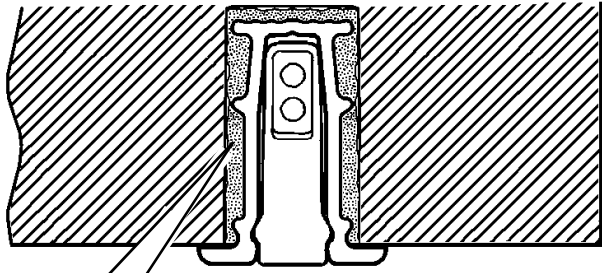

ALIMENTAZIONE  
POWER SUPPLY  
ALIMENTATION  
EINSPEISUNG  
STROOMVERZORGING  
ALIMENTACION  
STRØMFORSYNING  
STRØMFORSYNING  
ELFØRSØRJNING  
ЭЛЕКТРОПИТАНИЕ  
电源

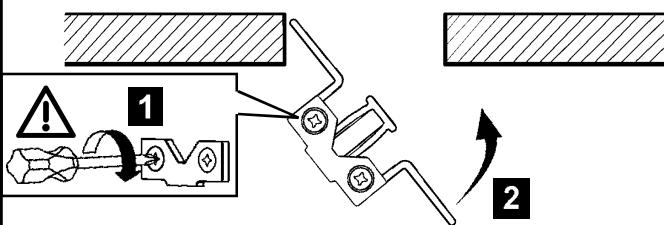
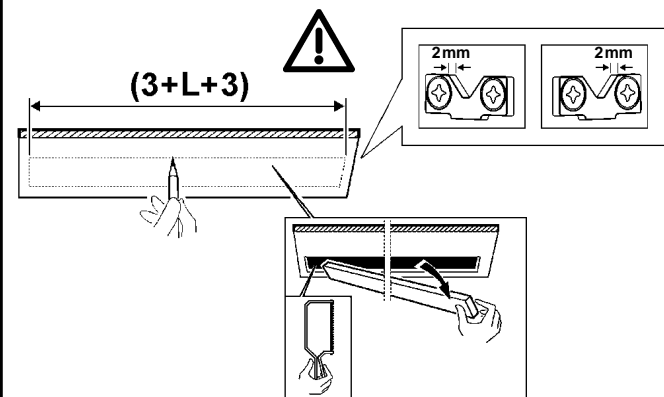
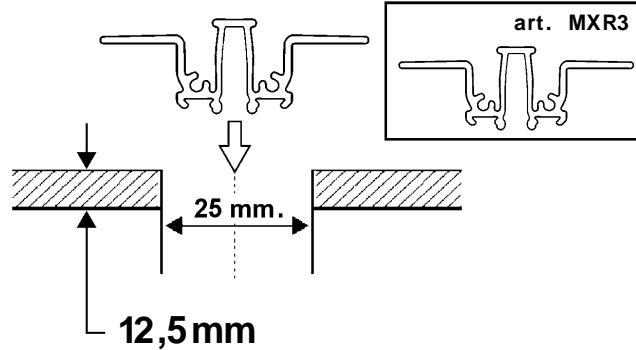
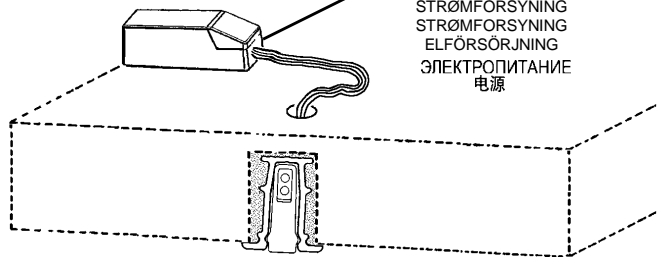

ALIMENTAZIONE  
POWER SUPPLY  
ALIMENTATION  
EINSPEISUNG  
STROOMVERZORGING  
ALIMENTACION  
STRØMFORSYNING  
STRØMFORSYNING  
ELFØRSØRJNING  
ЭЛЕКТРОПИТАНИЕ  
电源

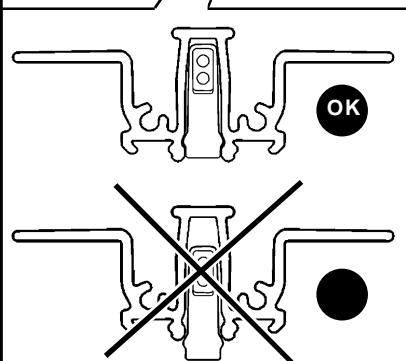
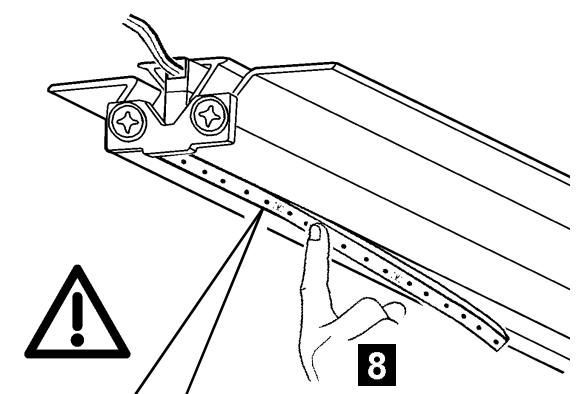
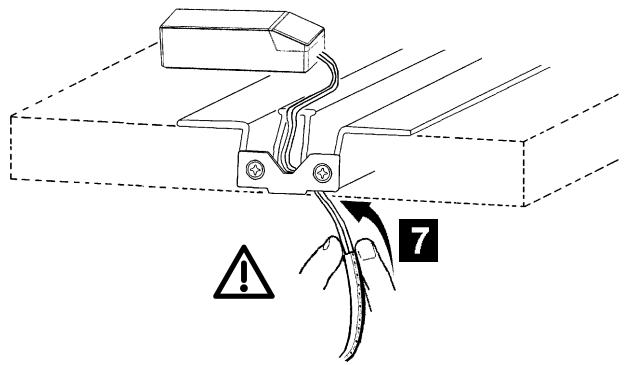
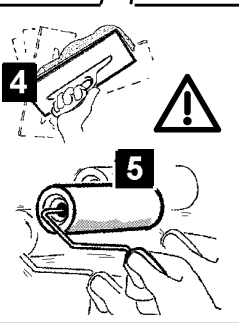
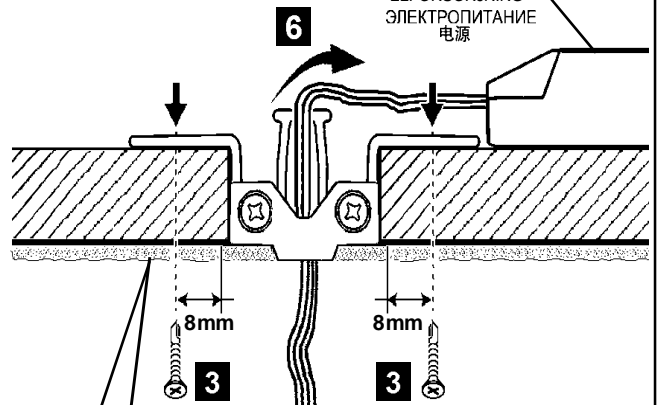

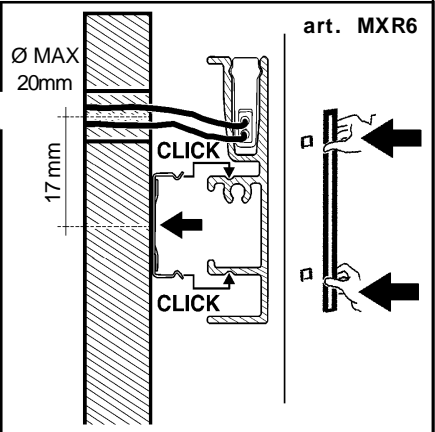
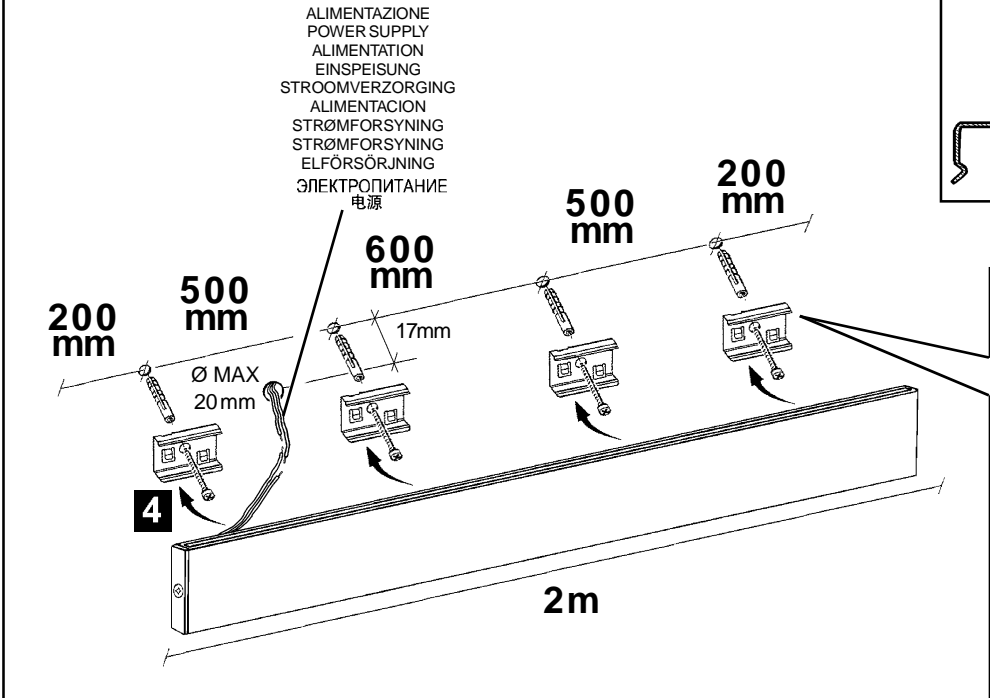
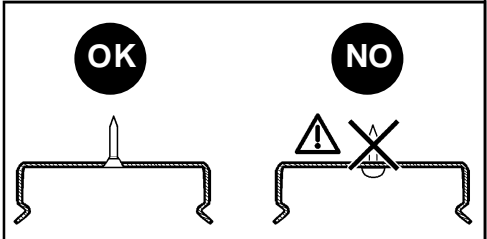
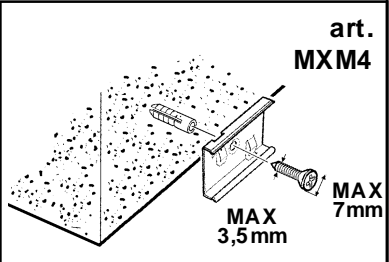
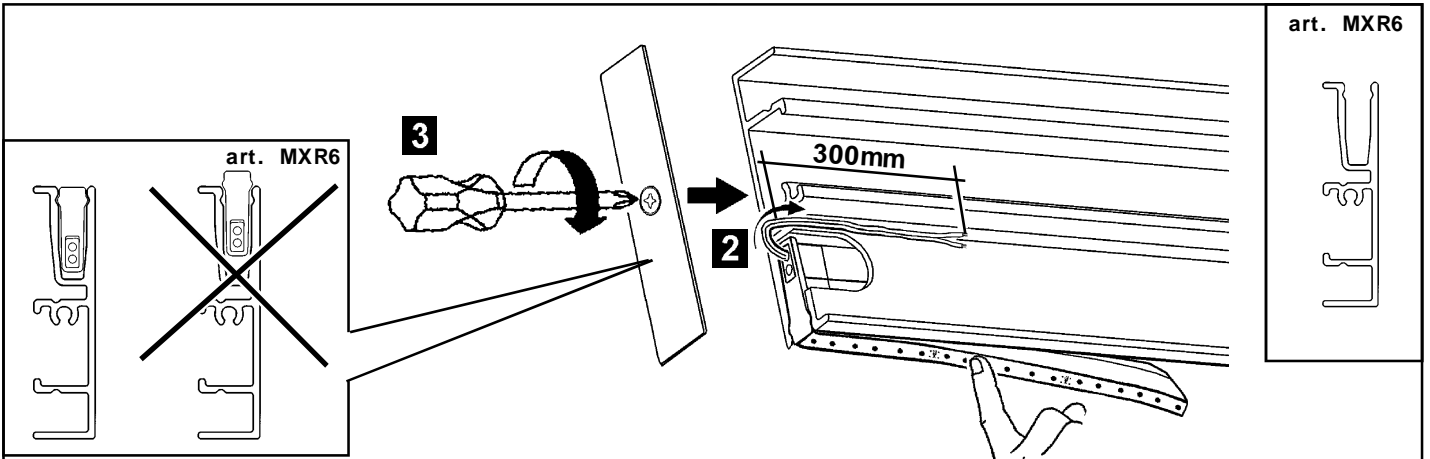

art. MXR7

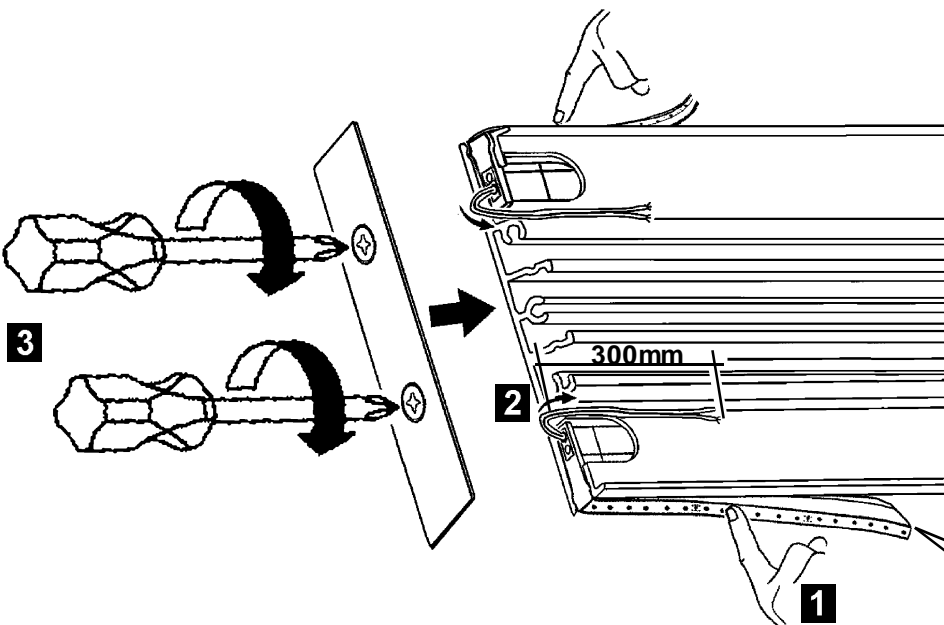

art. MXR7

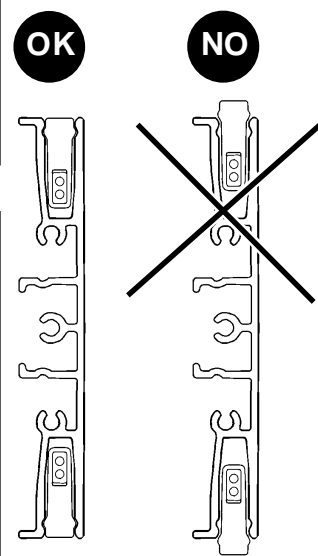

art. MXM4

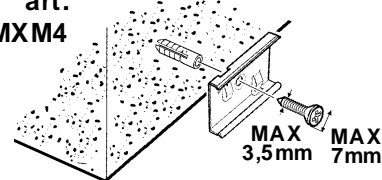

ALIMENTAZIONE  
 POWER SUPPLY  
 ALIMENTATION  
 EINSPEISUNG  
 STROOMVERZORGING  
 ALIMENTACION  
 STRØMFORSYNING  
 STRØMFORSYNING  
 ELFÖRSÖRJNING  
 ЭЛЕКТРОПИТАНИЕ  
 电源

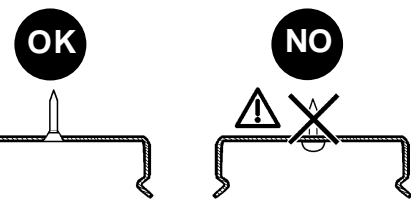
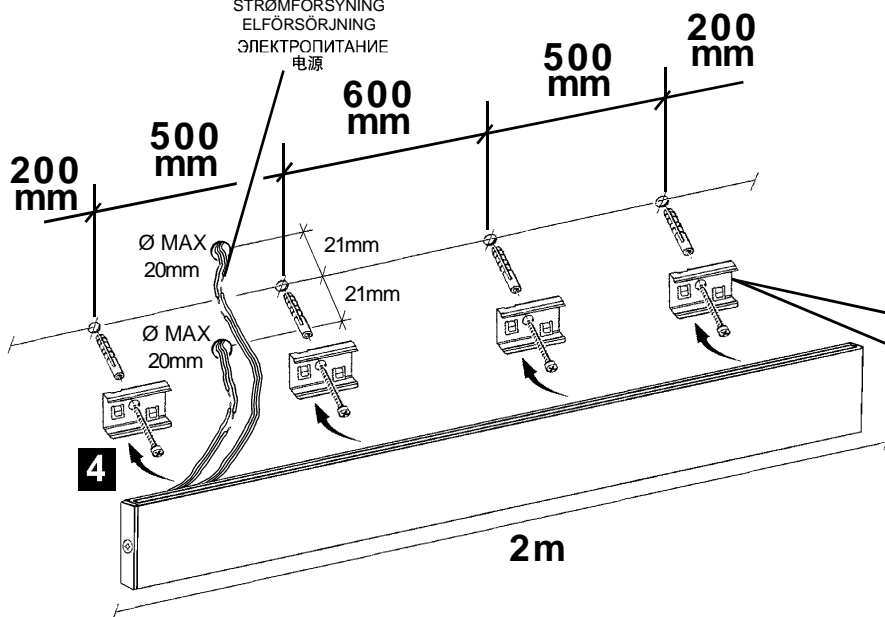

art. MXR7

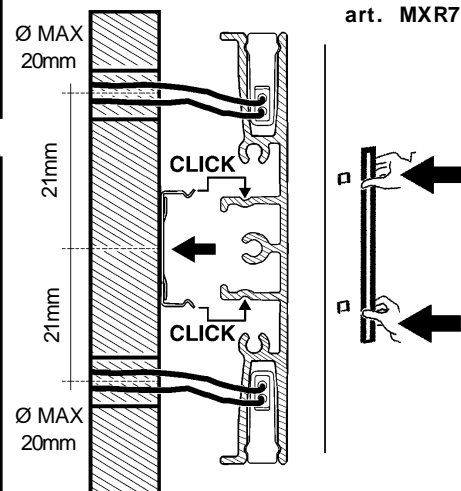



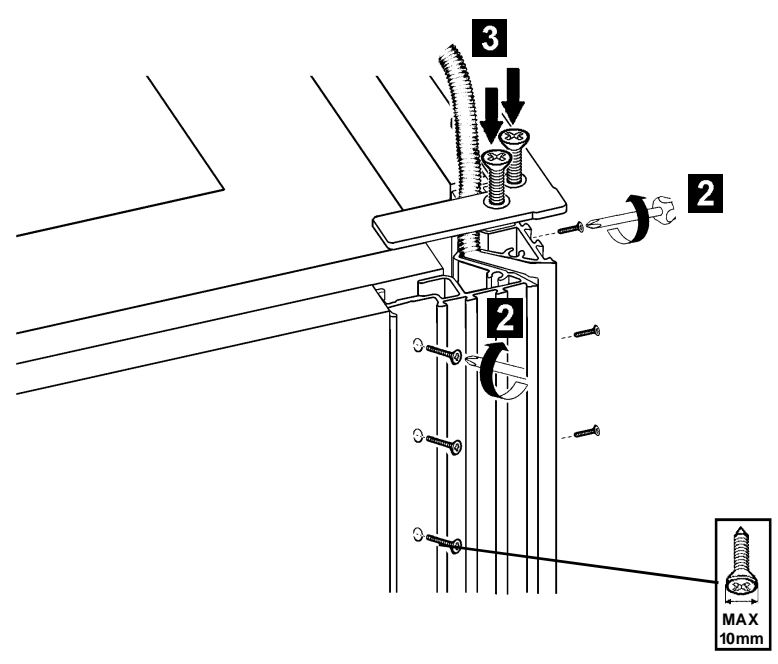
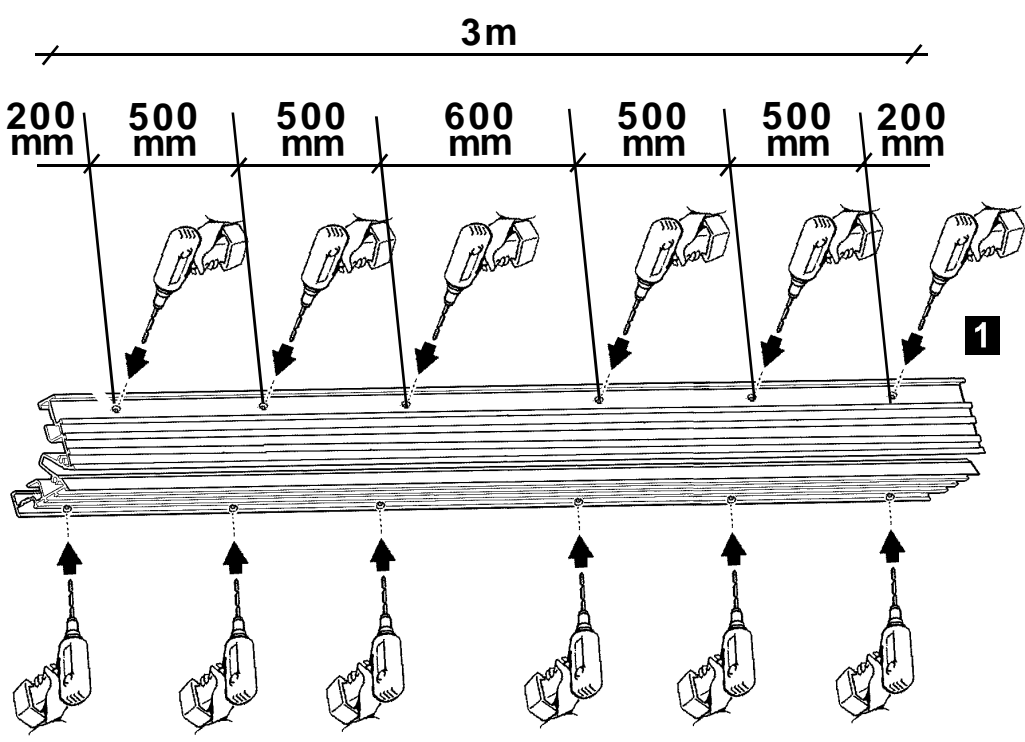
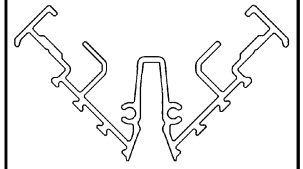

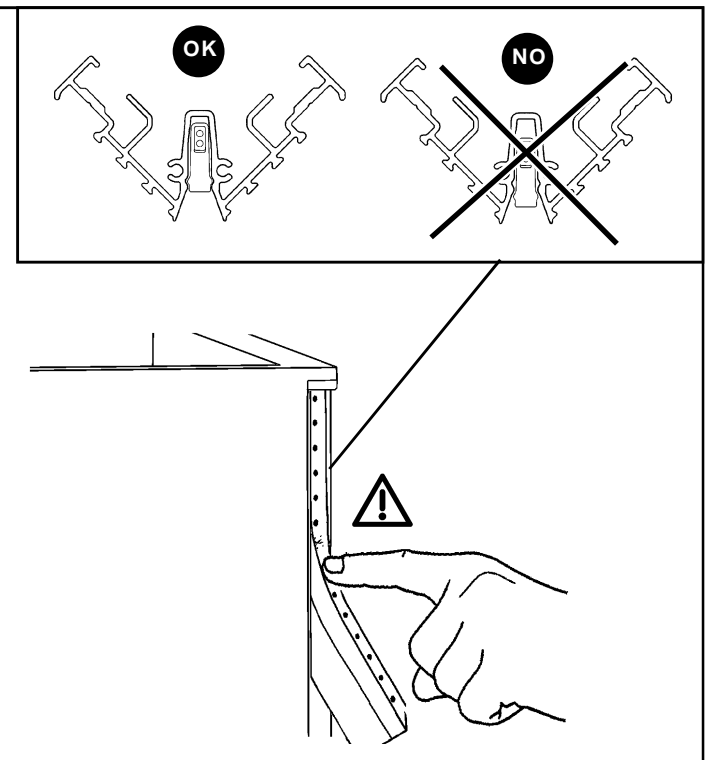
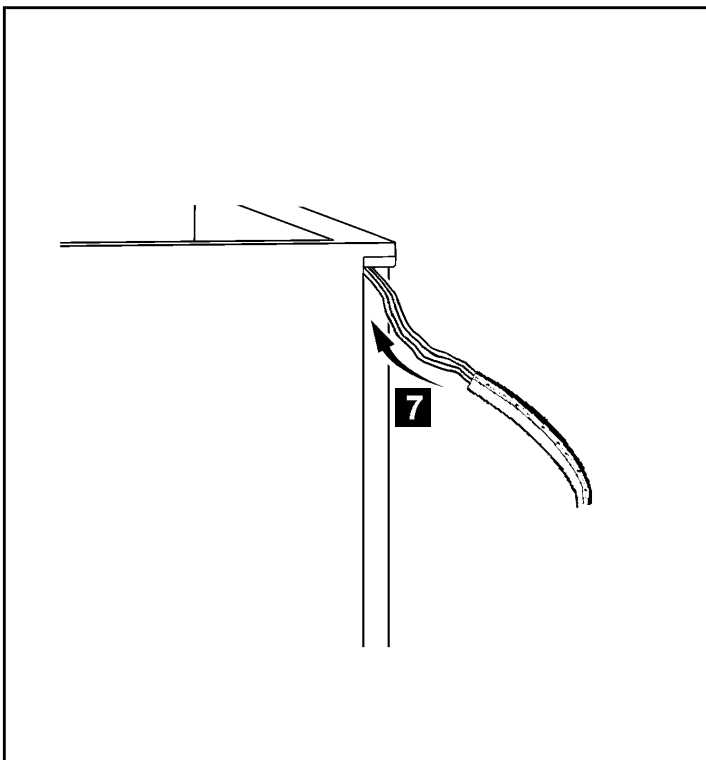
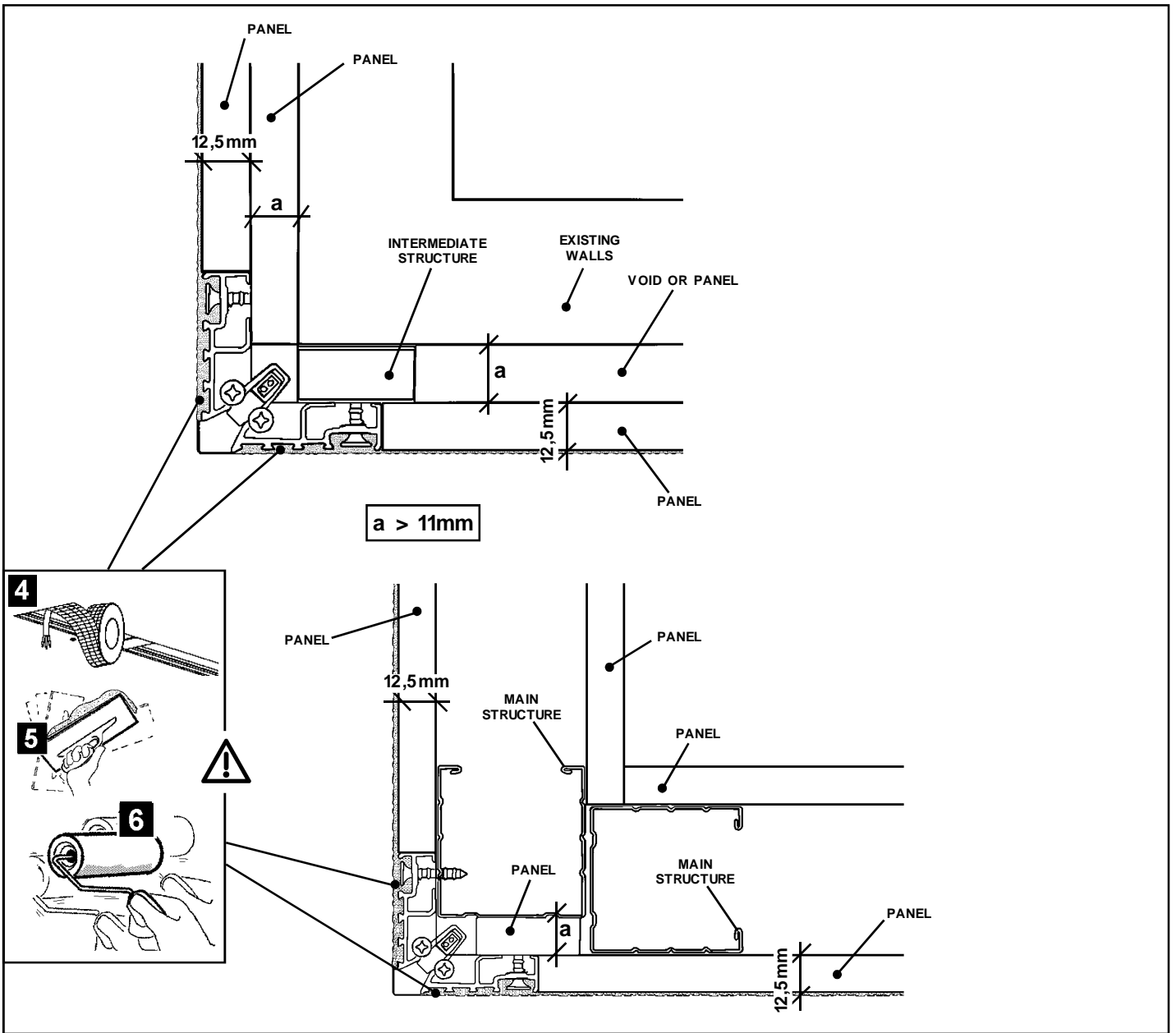

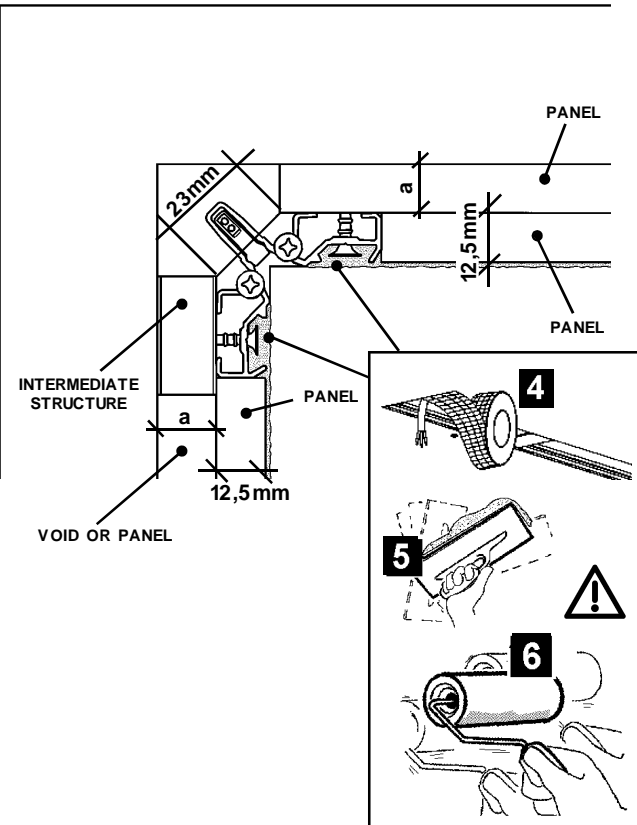
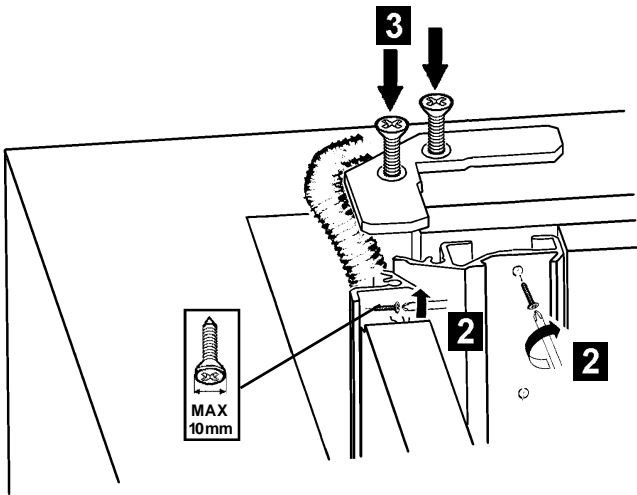
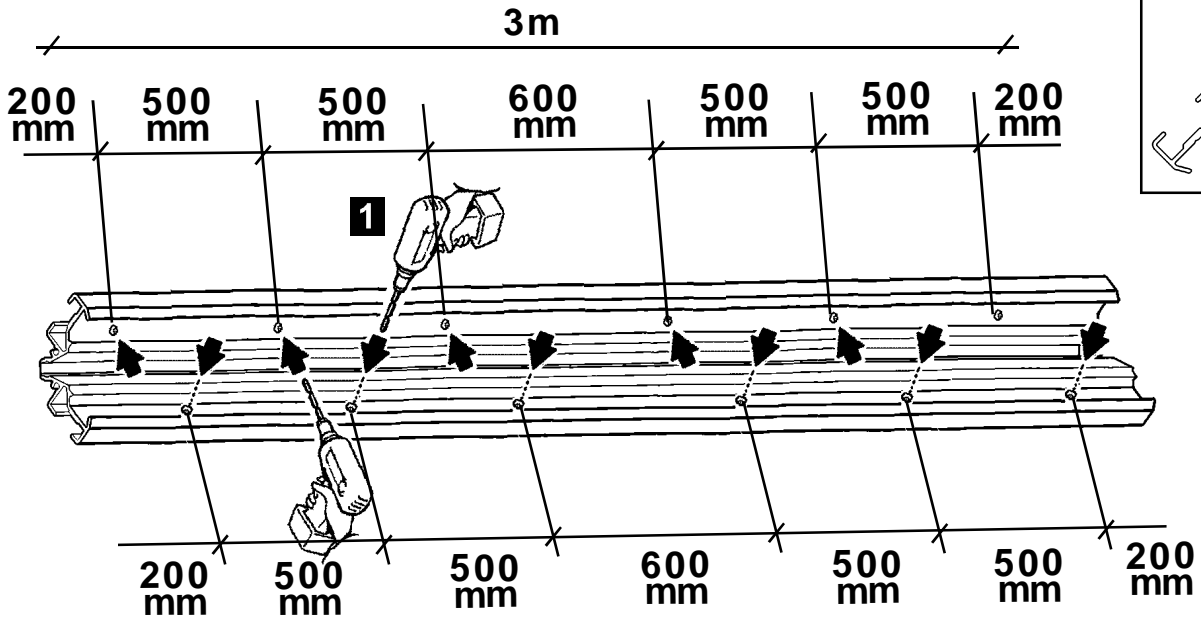
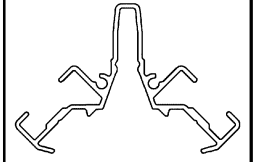

a > 3

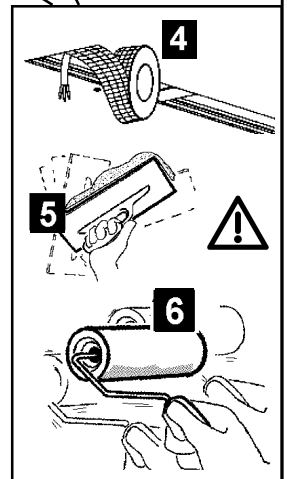
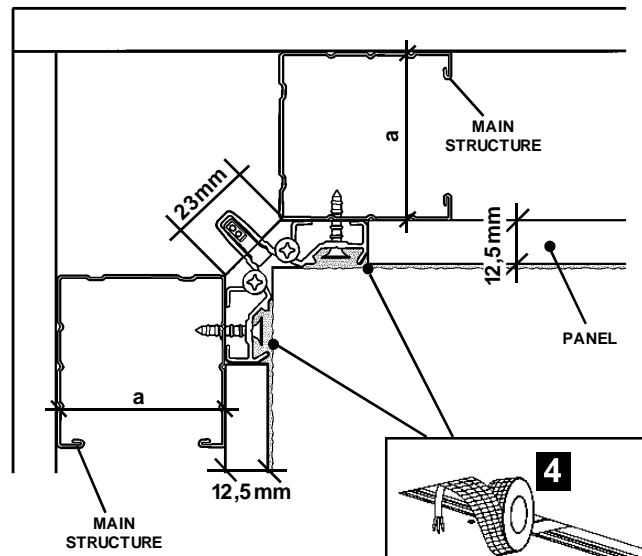

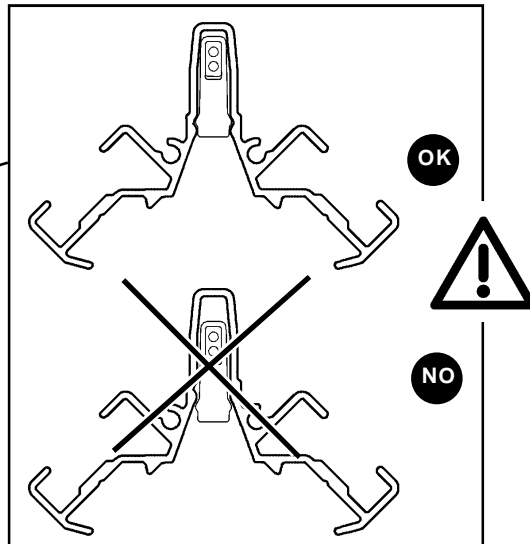
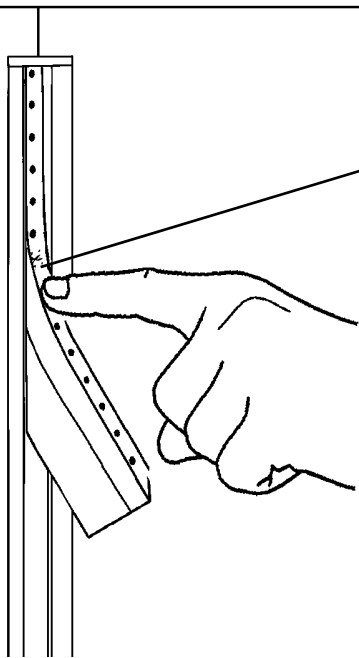
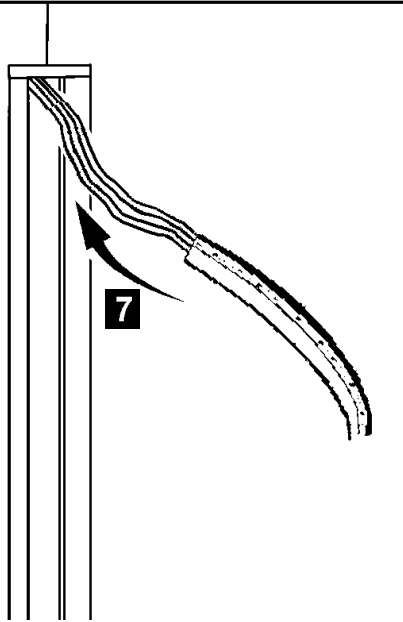

- I "Il cavo non può essere sostituito; se il cavo è danneggiato l'apparecchio deve essere distrutto"
- GB "The cable cannot be replaced. If the cable is damaged, the fixture must be destroyed"
- F « Le câble ne peut pas être remplacé. Si le câble est endommagé, l'appareil doit être détruit »
- D „Das Kabel kann nicht ausgetauscht werden; wenn das Kabel beschädigt ist, muss die Leuchte entsorgt werden"
- NL "De kabel mag niet worden vervangen. Als de kabel beschadigd is, moet u het apparaat vernietigen"
- E "El cable no puede sustituirse; si el cable está dañado el aparato debe destruirse"
- DK "Ledningen må ikke udskiftes. Hvis den bliver beskadiget, skal apparatet bortskaffes"
- N "Ledningen kan ikke skiftes ut. Hvis den er skadet, må man kassere apparatet"
- S "Kabeln kan inte bytas ut. Om kabeln är skadad måste apparaten kasseras"
- RUS «Сетевой шнур не подлежит замене; в случае повреждения сетевого шнура необходимо заменить прибор»
- CN "电缆无法更换。如果电缆损坏，灯具必须予以销毁"

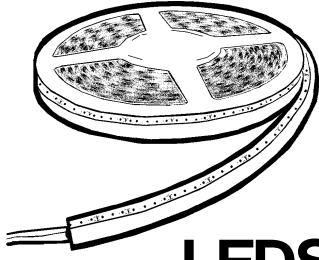

## LEDSTRIP 50W (underscore6)

تحذير:

لا يمكن ضمان سلامة هذا الجهاز إلا إذا التزمت بهذه التعليمات. يجب حفظها في مكان آمن.

**ATTENZIONE:**

LA SICUREZZA DELL'APPARECCHIO E' GARANTITA SOLO CON L'USO APPROPRIATO DELLE SEGUENTI ISTRUZIONI; PERTANTO E' NECESSARIO CONSERVARLE.

**WARNING:**

THE SAFETY OF THIS FIXTURE IS GUARANTEED ONLY IF YOU COMPLY WITH THESE INSTRUCTIONS; REMEMBER TO CONSERVE IN A SAFE PLACE.

**ATENCION:**

LA SEGURIDAD DEL APARATO SE GARANTIZA SOLO CUMPLIENDO CUIDADOSAMENTE LAS SIGUIENTES INSTRUCCIONES; POR ELLO, ES NECESARIO CONSERVARLAS.

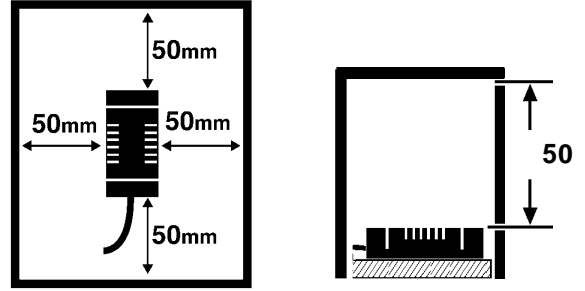
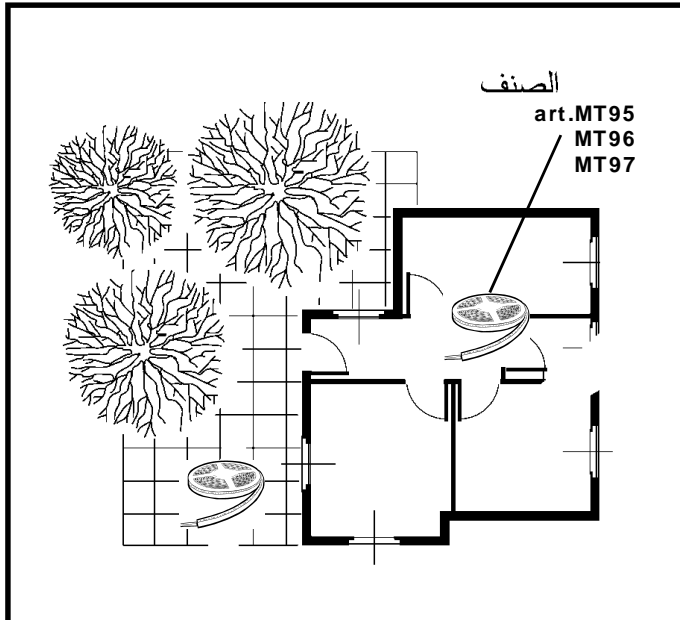
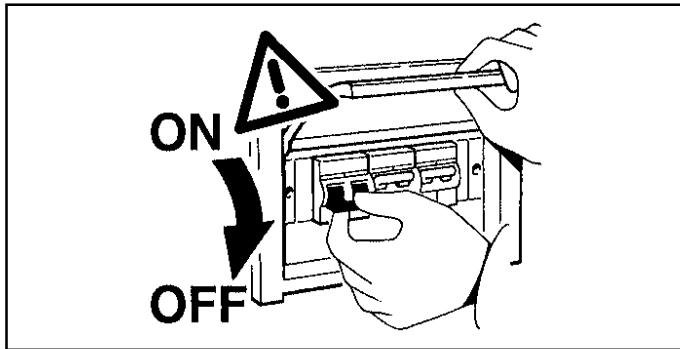

تعامل مع المنتج بعناية وحرص، ولا تُعرَضه للإجهادات الميكانيكية

I Maneggiare con cura e non sottoporre a tensioni meccaniche.

GB Handle with care and do not subject to mechanical stress.

E Manejar con cuidado y no someter a tensiones mecánicas

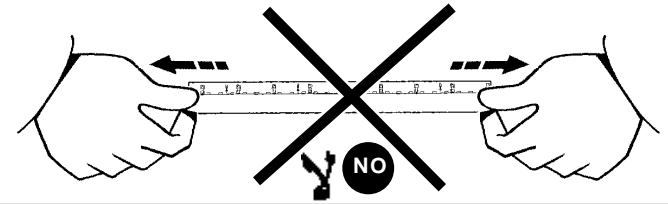
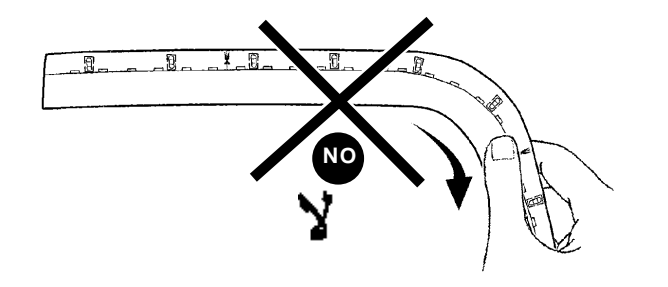
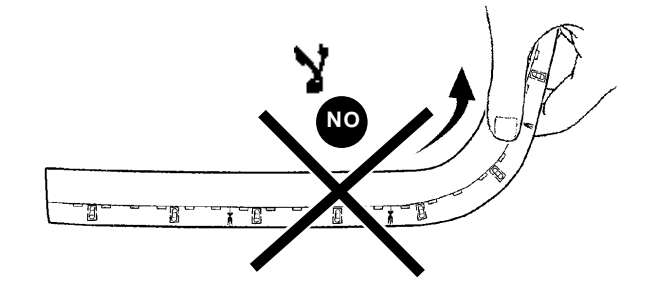
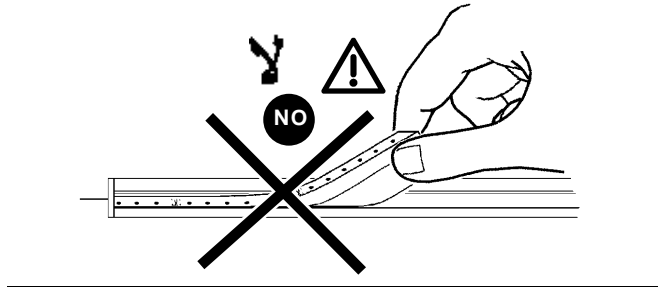
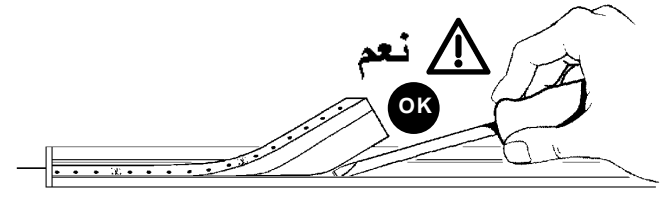

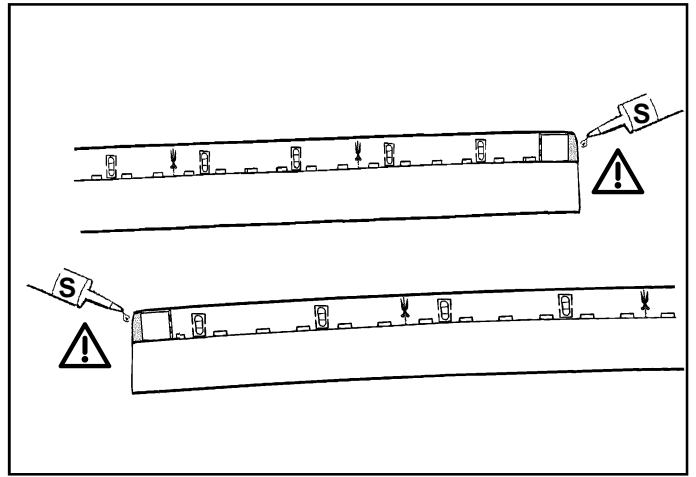
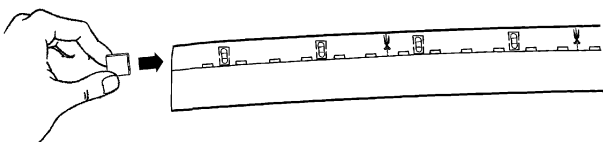
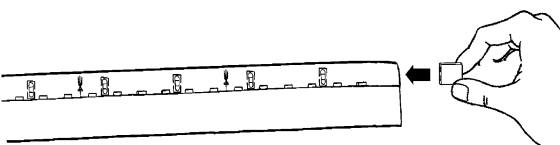
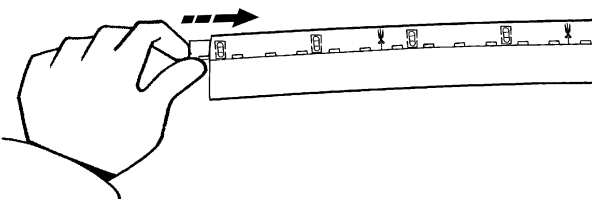
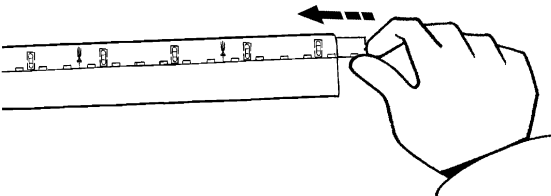
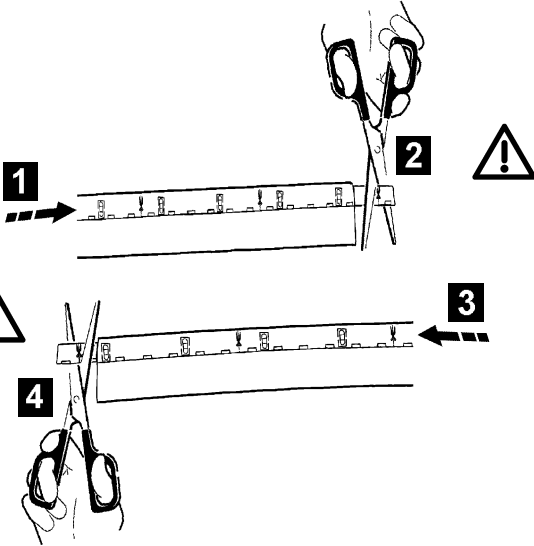
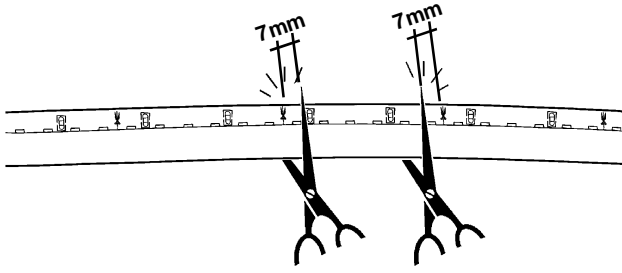

ملاحظة: يتم ضمان درجة حماية النظام، وذلك فقط في حالة إجراء عملية السلكنة (معالجة المادة بالسيليكون) بطريقة صحيحة وباستخدام السيليكون الذي يتم توريده من قِبَل مؤسسة "إيجوزيني"

**I N.B.:** Il grado di protezione del sistema, é garantito soltanto se si effettua correttamente l'operazione di siliconatura (S) con silicone fornito dalla iGuzzini.

**GB N.B.:** The degree of protection offered by the system is only guaranteed if the siliconisation procedure is performed correctly (S) using silicone supplied by iGuzzini.

**E N.B.:** El grado de protección del sistema está garantizado sólo si se realiza correctamente la operación de siliconado (S) con silicona suministrada por iGuzzini.

	MAX mt
الصنف ART	كابح ALIMENTATORE BALLAST ALIMENTADOR
	MZ14 - MZ15
MT95 MT96 MT97	8

ومن الممكن التجميع في سلسلة يصل طولها إلى خمسة أمتار من قطاعات لمبات الـ LED مع القبول بالاختلاف في درجات سطوع الضوء على طول خط الإضاءة

**I** E' possibile collegare in serie fino a 5m di Led Strip accettando delle differenze di luminosità sulla linea

**GB** The in-series connection of LED strips is possible up to 5 m allowing for any differences in luminosity on the line.

**E** Se puede conectar en serie hasta 5m de "Led Strip" aceptando diferencias de luminosidad en la línea.

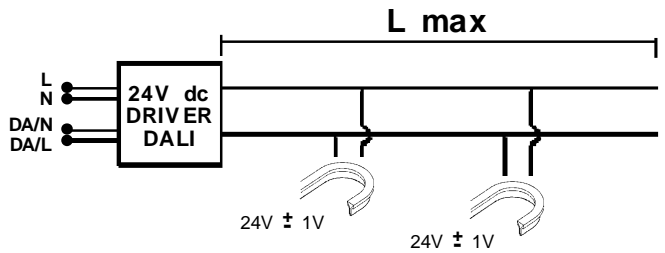
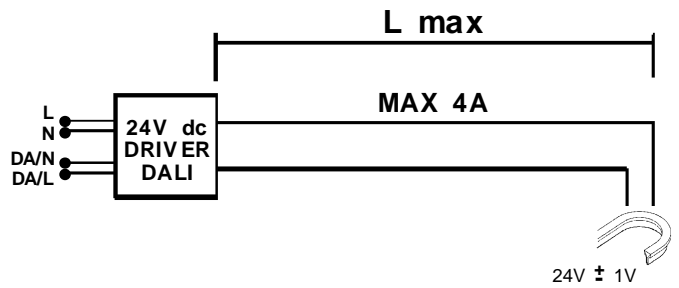
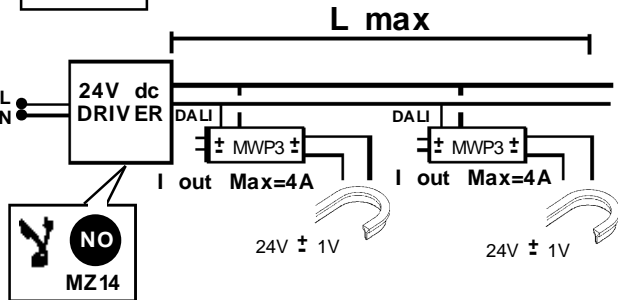
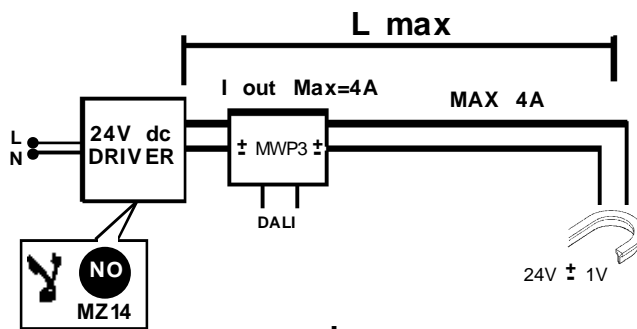
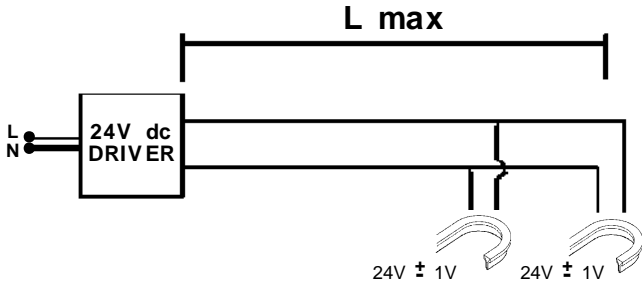
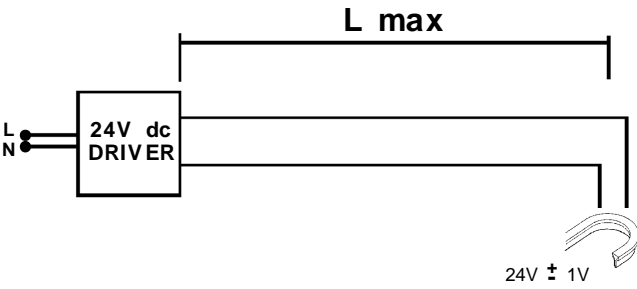

الصنف ART	Ampere/m [A]
MT95 MT96 MT97	0.45

$$L = \frac{25 \times S}{A \times m}$$

[mm<sup>2</sup>] مقطع كبل من النحاس = S  
 أمبير/متر = A  
 مجموع الأمتار الموصولة بالخط = M

S = Sezione cavo in Rame [mm<sup>2</sup>]  
 A = Ampere/m  
 m = Metri totali collegati alla Linea  
 S= Copper cable section [mm<sup>2</sup>]  
 A= Ampere/m  
 m= Total metres connected to the line  
 S= Sección cable de cobre [mm<sup>2</sup>]  
 A= Ampere/m  
 m= Metros totales conectados a la línea

art MZ14 - MZ15

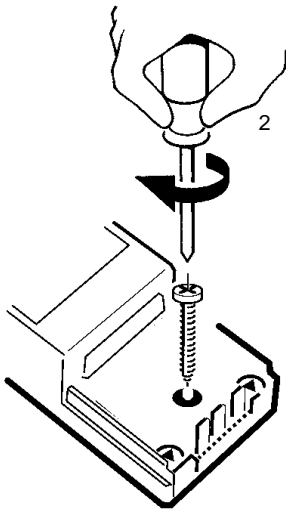
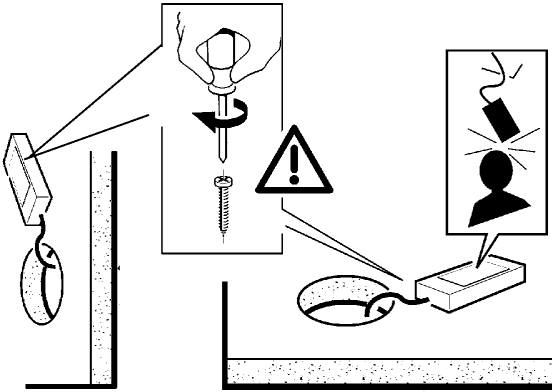

art MZ14 - MZ15

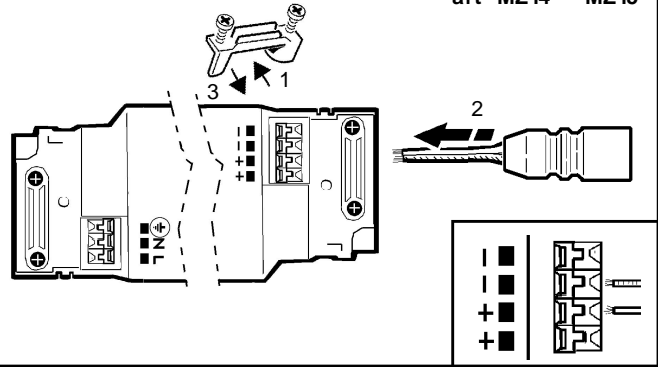

يتم ضمان عمل وسلامة الجهاز فقط إذا كان تردد التيار يعادل  $\pm 5\%$  مقارنة مع القيمة الاسمية.  
يتم ضمان التوافق فقط إذا كانت كوابح iGuzzini (سلعة رقم MZ14 - MZ15) أو ما يشابهها من نوع SELV متوافقة مع النظم المساندة والحددة من قبل مجموعة الدول الأوروبية.

I Le prestazioni e la sicurezza dell'apparecchio sono garantite soltanto per oscillazioni della corrente del  $\pm 5\%$  rispetto al valore nominale.

La conformità alla norma è garantita soltanto utilizzando alimentatori iGuzzini (art.: MZ14 - MZ15) od equivalenti di tipo SELV che rispondano alle vigenti norme

GB The performance level and safety of the lighting fixture are only guaranteed for oscillations of  $\pm 5\%$  in the current, in relation to the nominal value.

Conformity with the standard is guaranteed only if either iGuzzini ballasts (item code MZ14 - MZ15) or equivalent SELV type ballasts which comply with current regulations are used.

E Las prestaciones y la seguridad del aparato están garantizada solamente con oscilaciones de la corriente del  $\pm 5\%$  respecto al valor nominal.

La conformidad a la norma se garantiza solamente con el uso de alimentadores iGuzzini (art. MZ14 - MZ15) o equivalentes de tipo SELV que cumplen las normas vigentes.

DALI

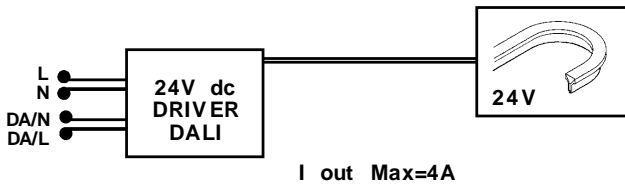

TOUCH DIM

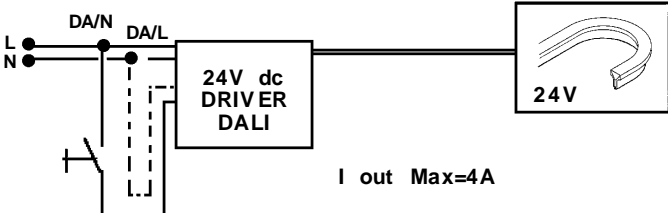



## لمحة إكسسوارات

ACCESSORI PROFILI  
PROFILES ACCESSORIES  
ACCESORIOS PERFILES

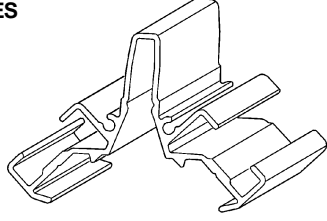

تنبيه: بما فيها لوحة أطراف التوصيل. يمكن أن تحتاج عملية التركيب إلى فني عر مختص.

المواصفات الفنية للوحة أطراف التوصيل:

- عدد 2 طرف توصيل من النوع الذي يكون على شكل برغي (مقطع بقياس 2.5 ملم كحد أقصى)
- فلتية التغذية 24 فولت - 6 أمبير
- تقشير كبلات 8 ملم

**I Morsettiera non inclusa. L'installazione può richiedere l'intervento di personale qualificato.**

Caratteristiche tecniche della morsettiera:

- n° 2 morsetti del tipo a vite (sezione max. 1mm<sup>2</sup>)
- tensione di alimentazione 24V - 6A
- spellatura cavi di 8 mm.

**GB Terminal board not included. The aid of qualified personnel may be required for installation.**

Technical features of the terminal board:

- 2 terminals with a screw base (max. cross-section 1 mm<sup>2</sup>)
- 24 V - 6 A supply voltage
- 8 mm cable stripping length

**E Clema de conexiones no incluida. La instalación puede necesitar la intervención de personal calificado.**

Características técnicas de la clema de conexiones:

- n. 2 terminales de tornillo (sección máx. 1 mm<sup>2</sup>)
- tensión de alimentación 24V - 6A
- peladura cables de 8 mm.

art. MXR1  
MXR2

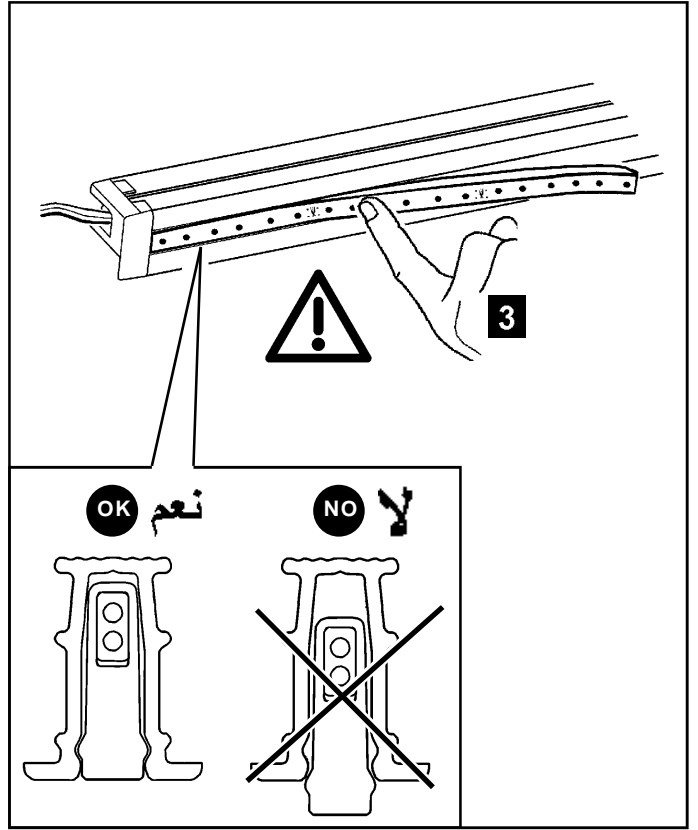
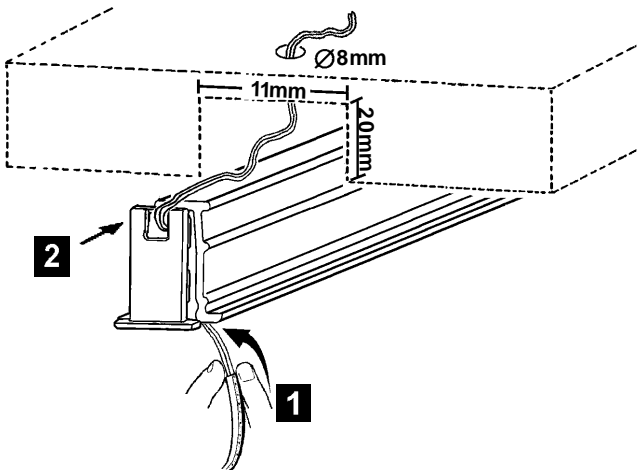
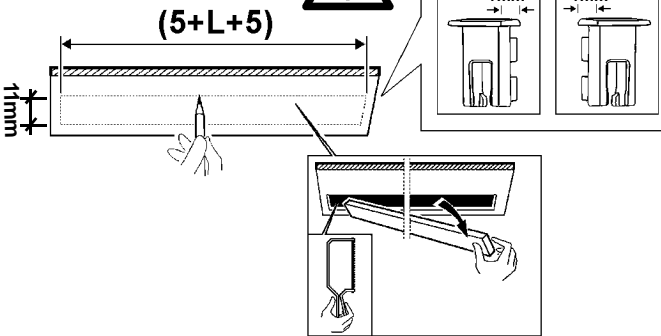
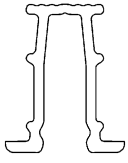

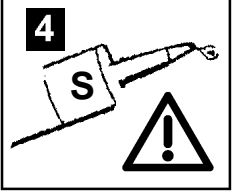
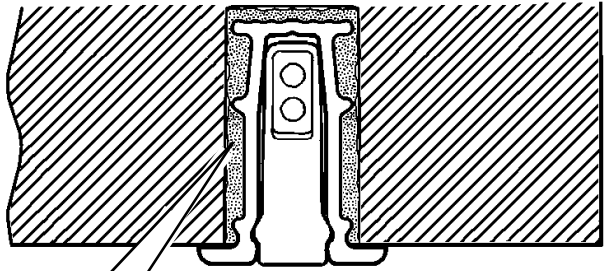

مصدر التيار  
ALIMENTAZIONE  
POWER SUPPLY  
CEBADOR

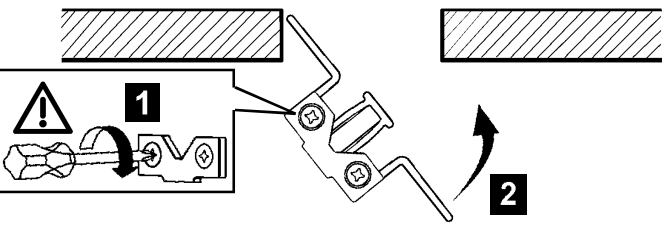
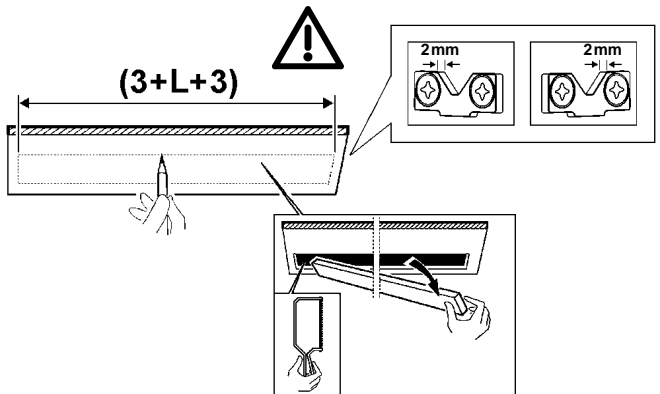
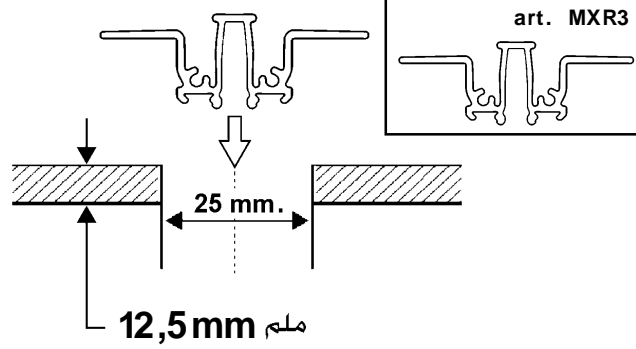
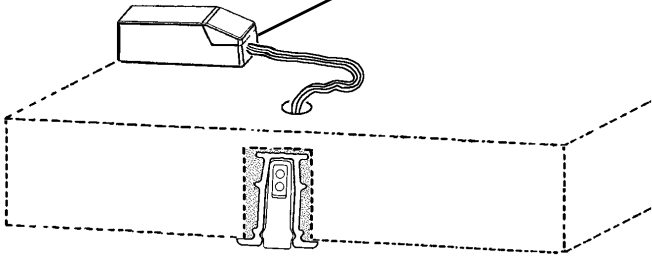

مصدر التيار  
ALIMENTAZIONE  
POWER SUPPLY  
CEBADOR

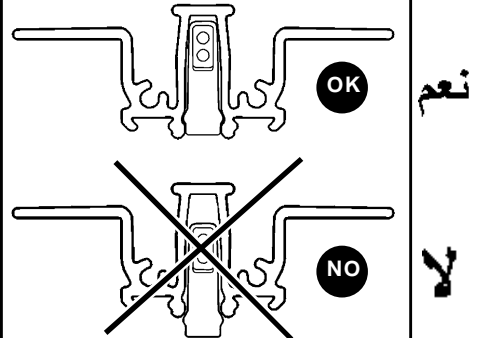
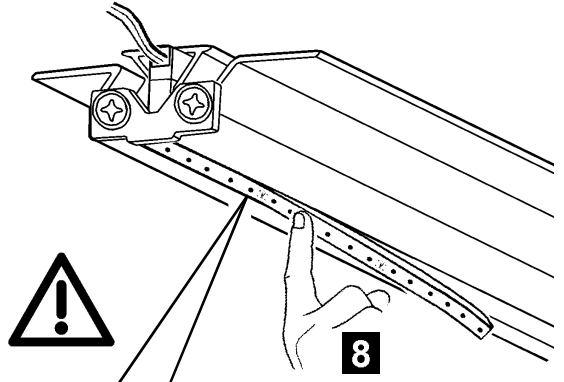
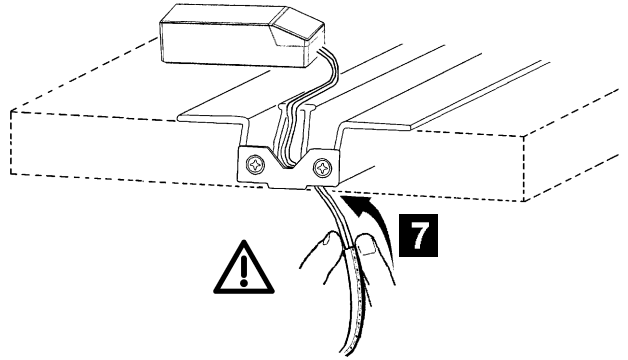
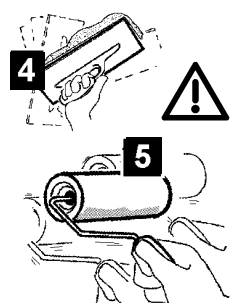
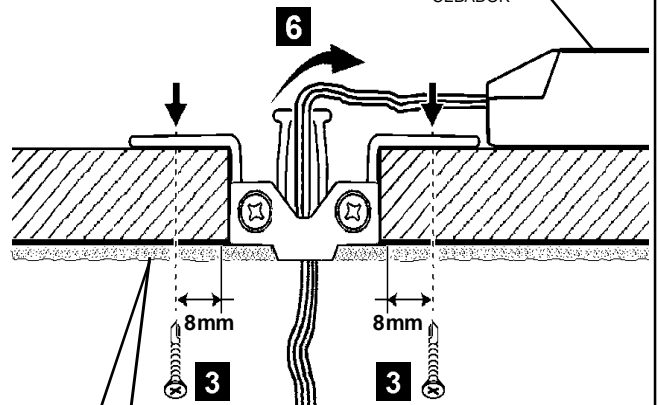

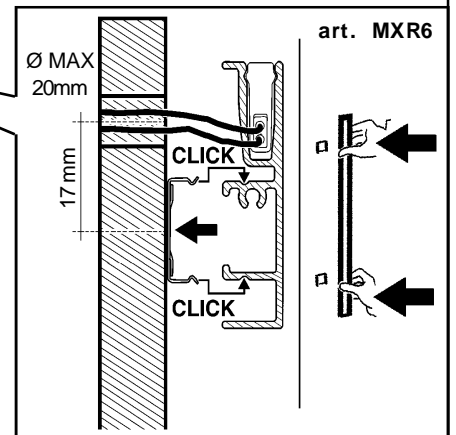
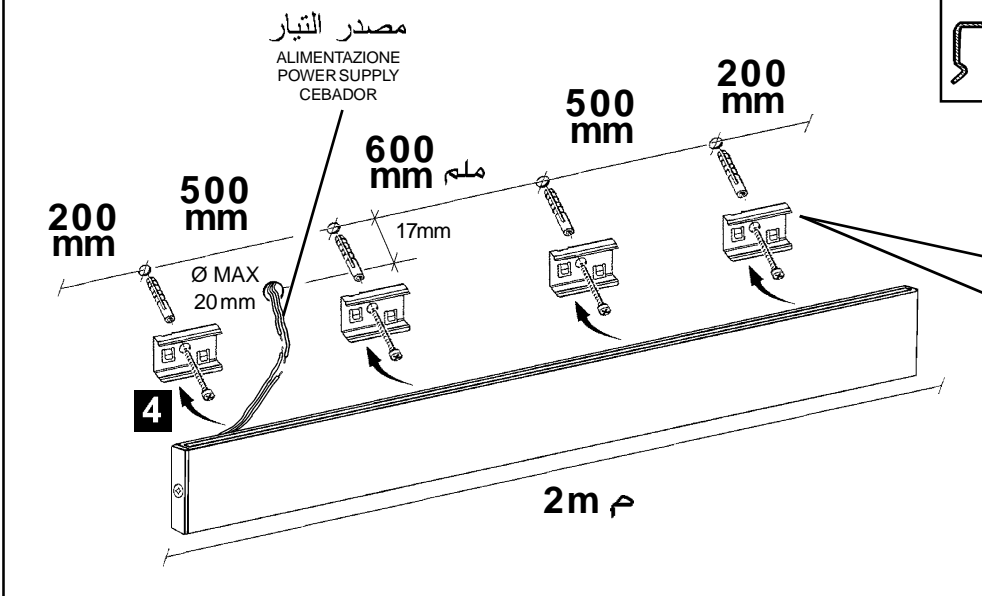
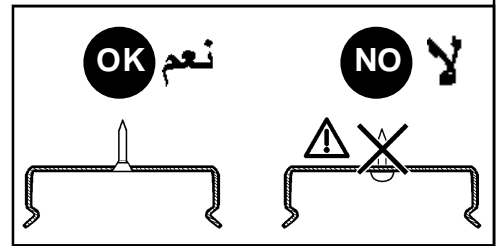
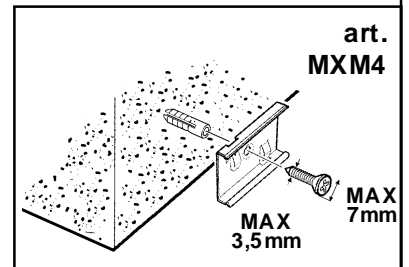
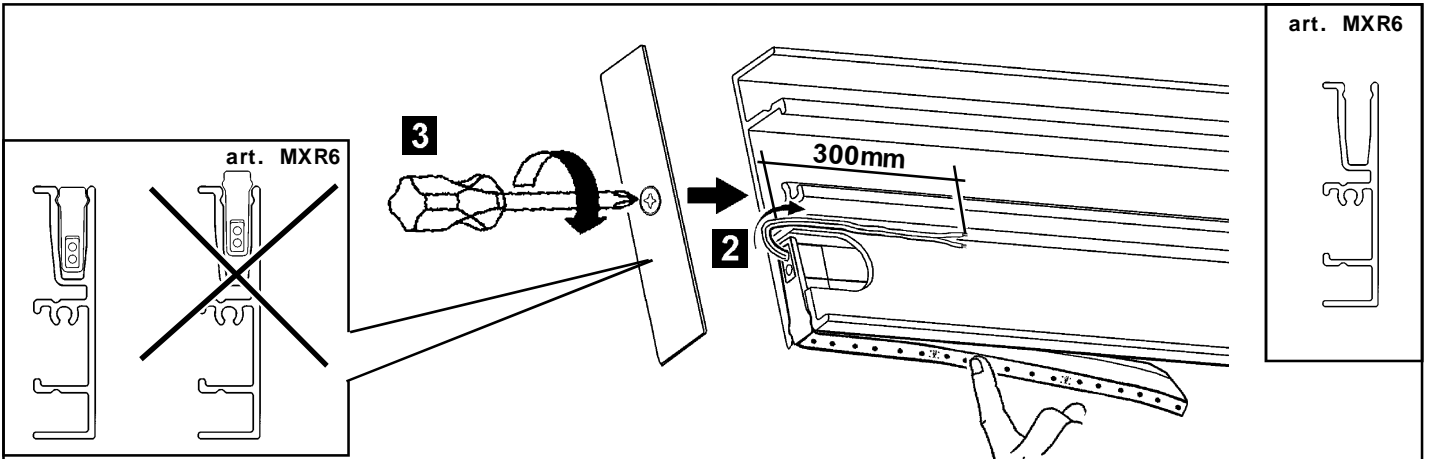

art. MXR7

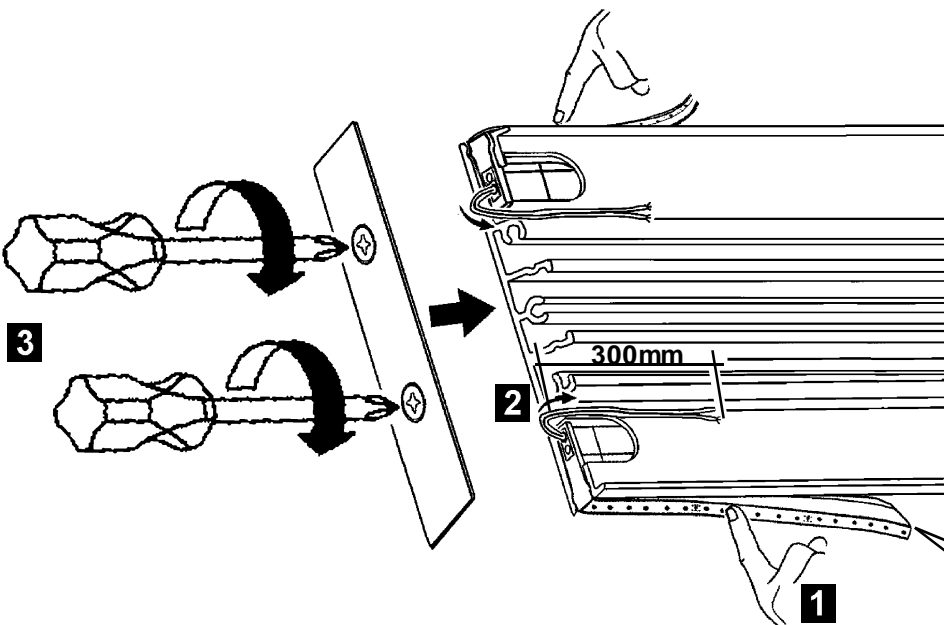

art. MXR7

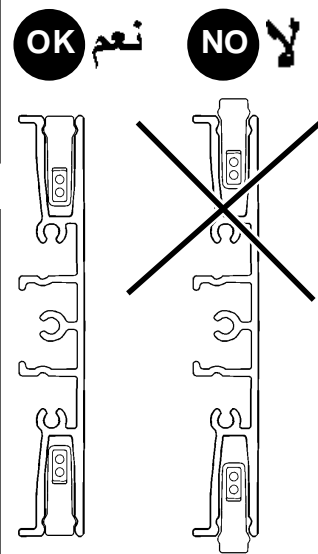

art. MXM4

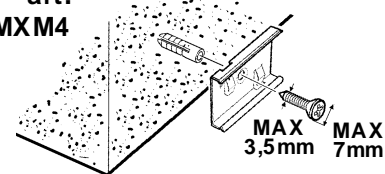

مصدر التيار  
ALIMENTAZIONE  
POWER SUPPLY  
CEBADOR

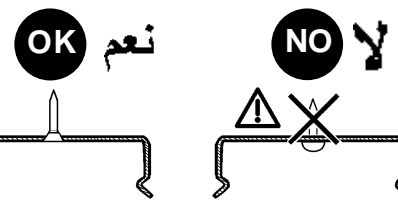
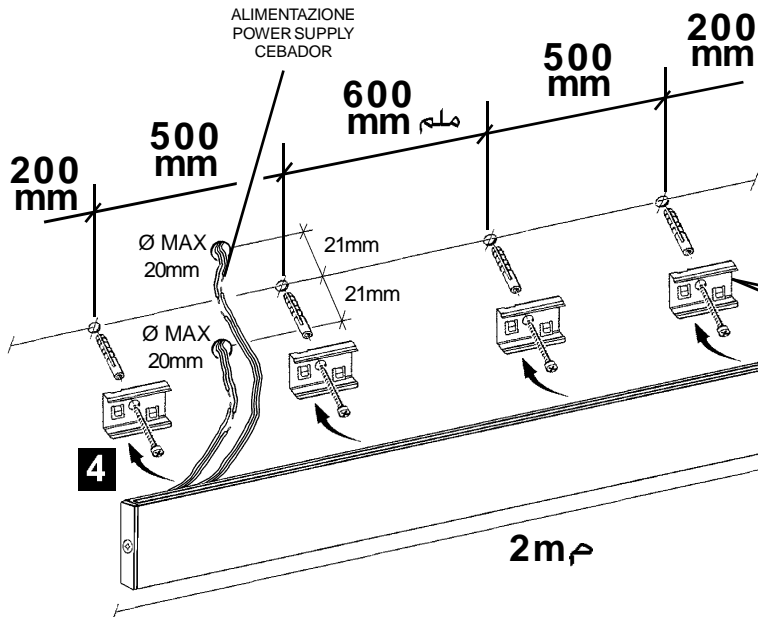

art. MXR7

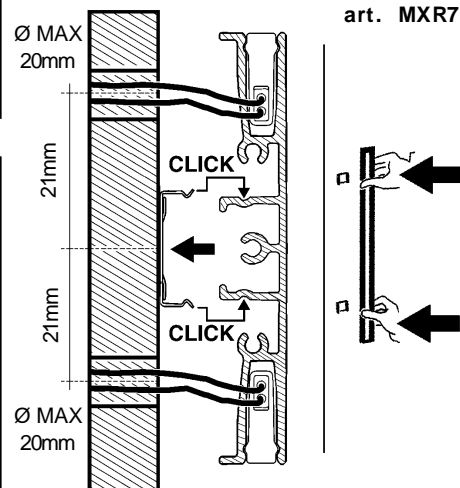

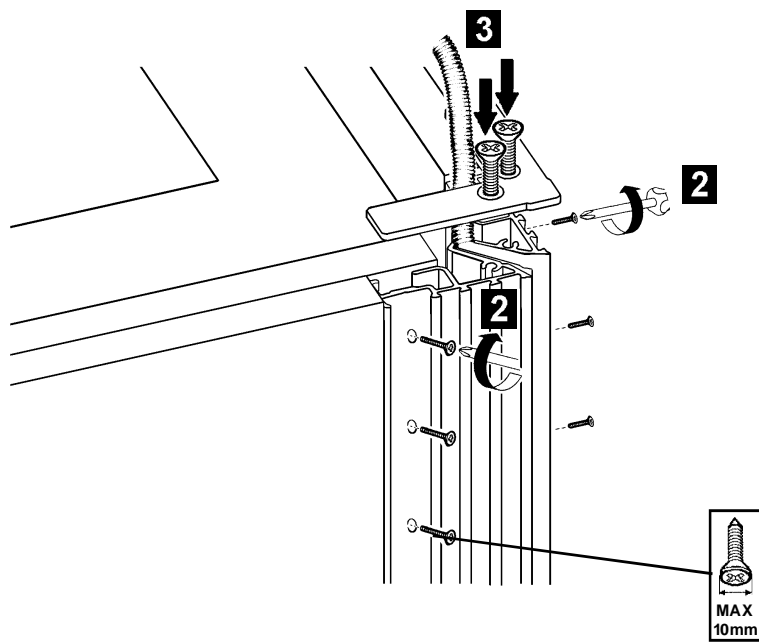
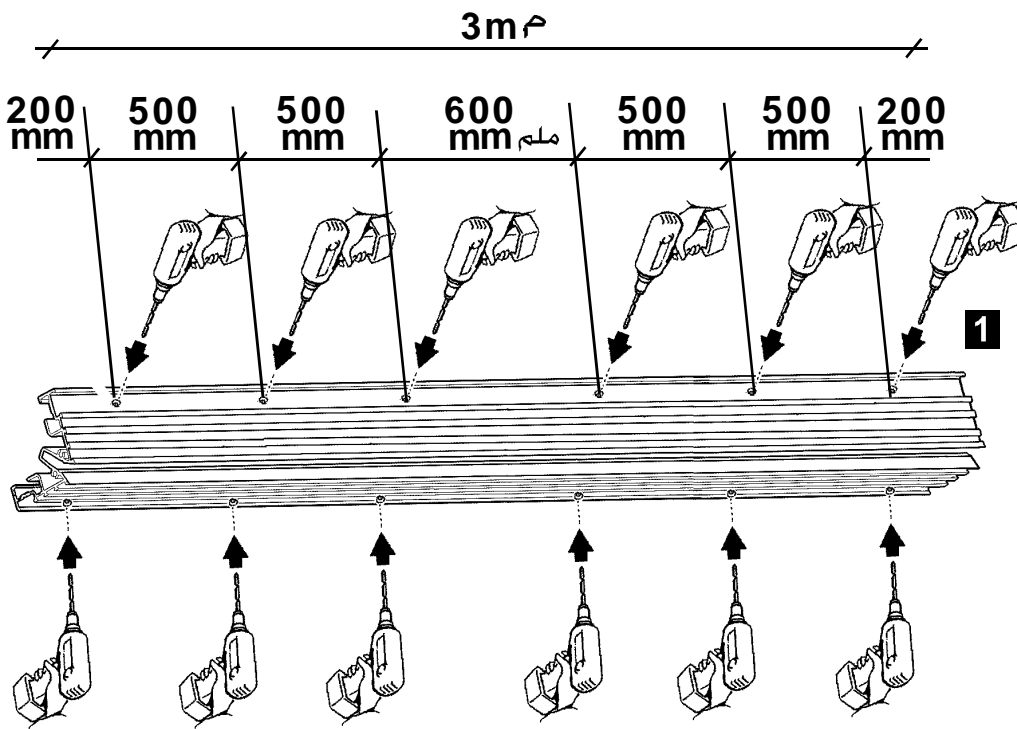
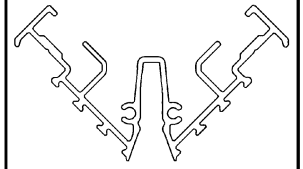

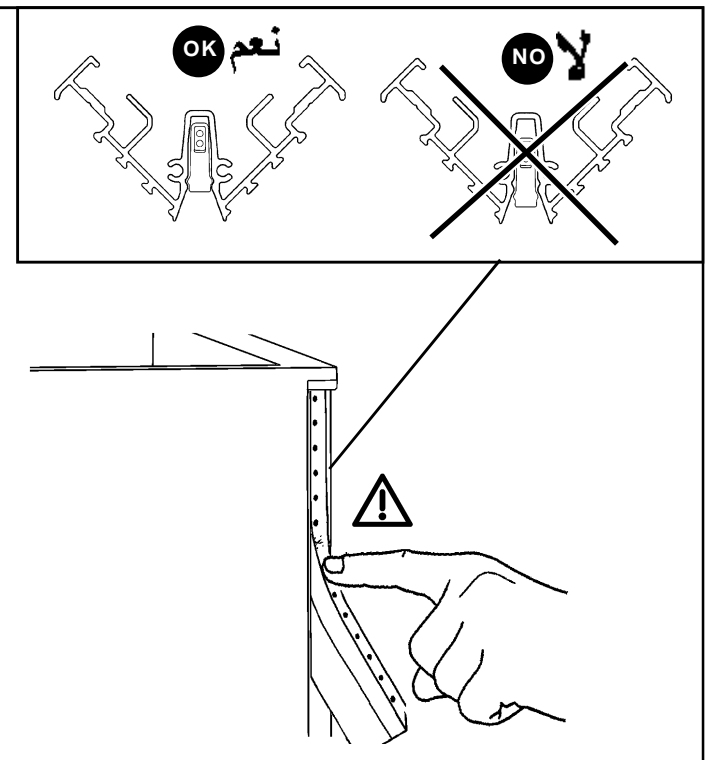
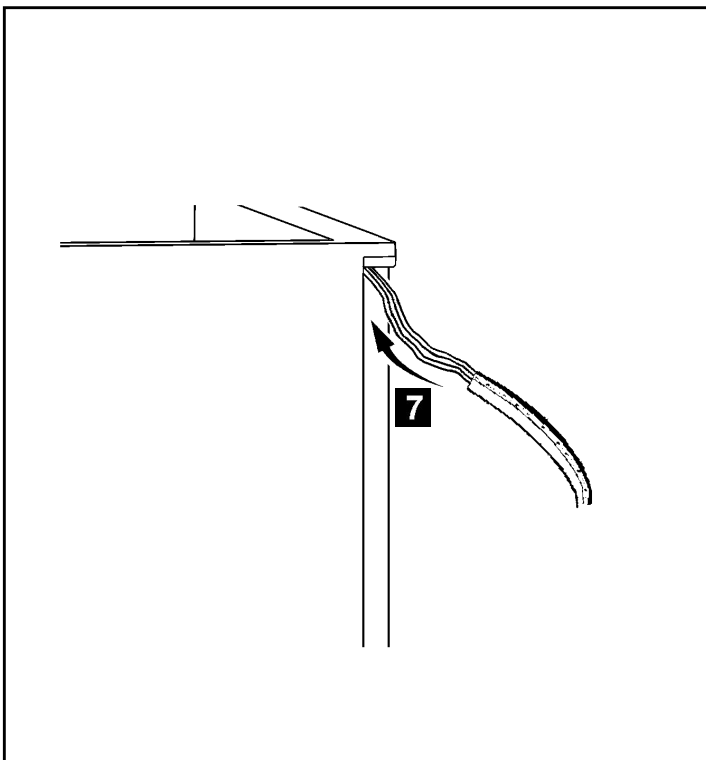
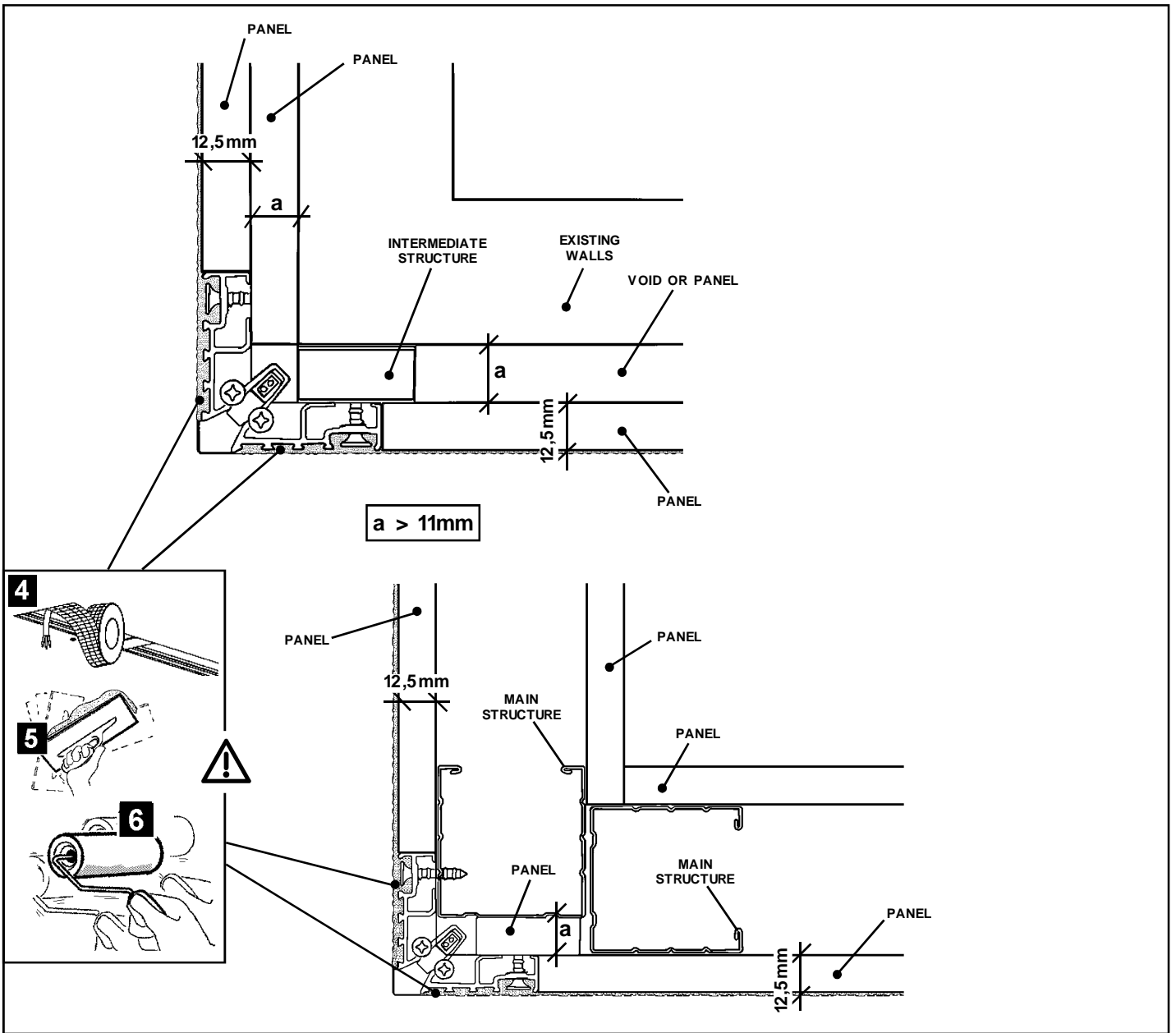

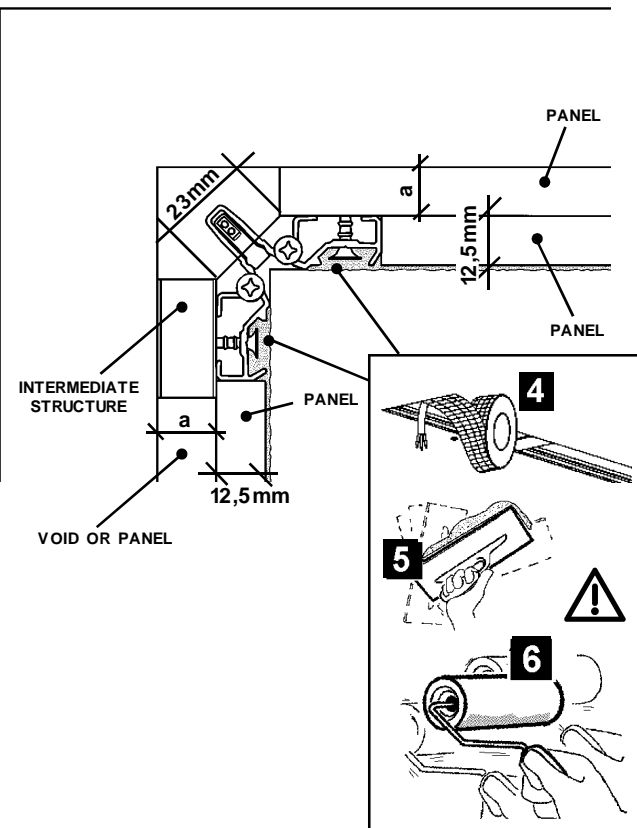
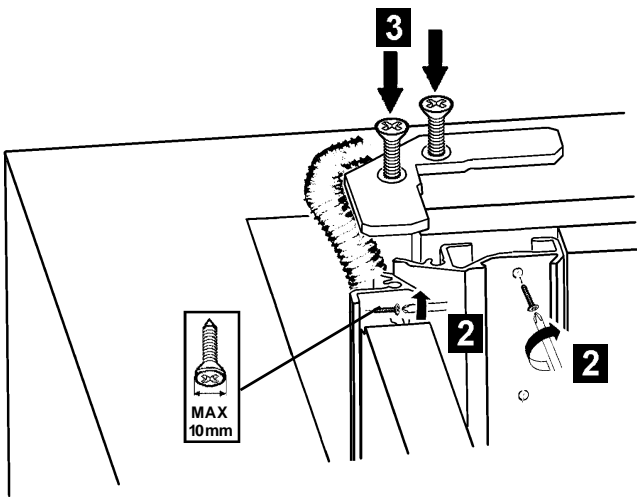
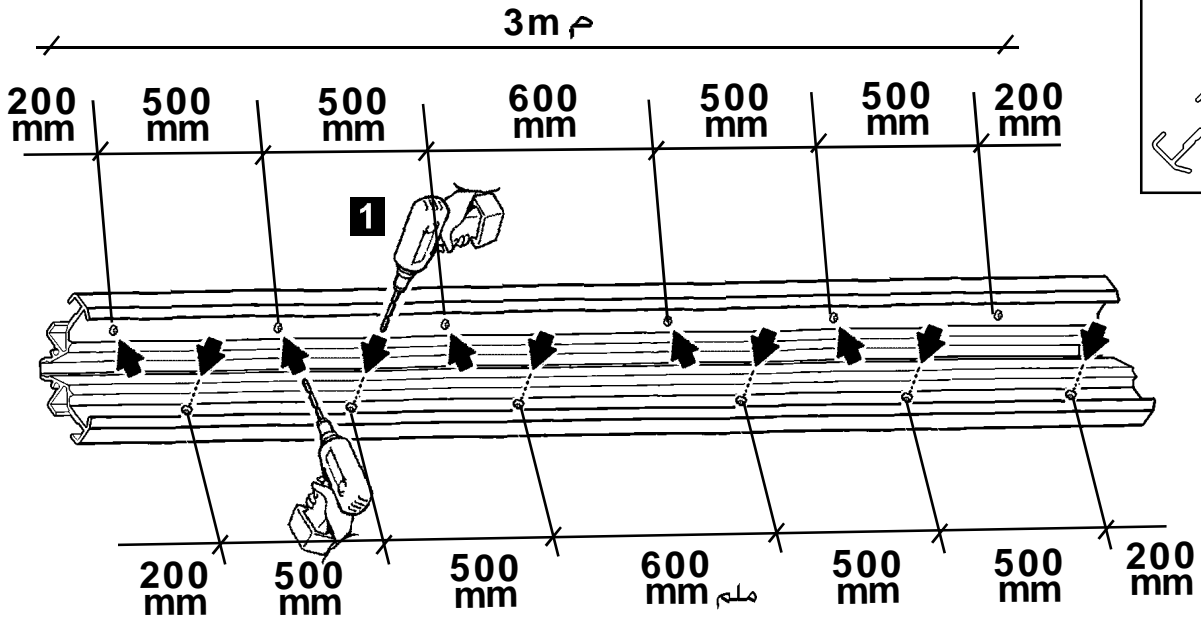
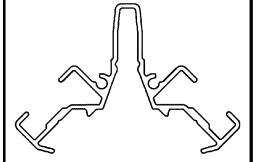

a > 3

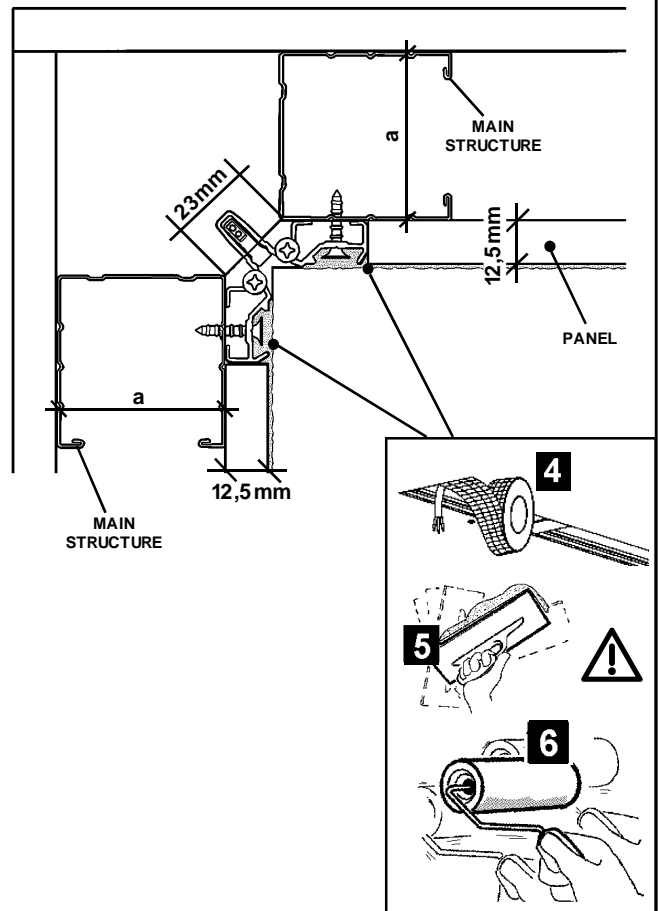

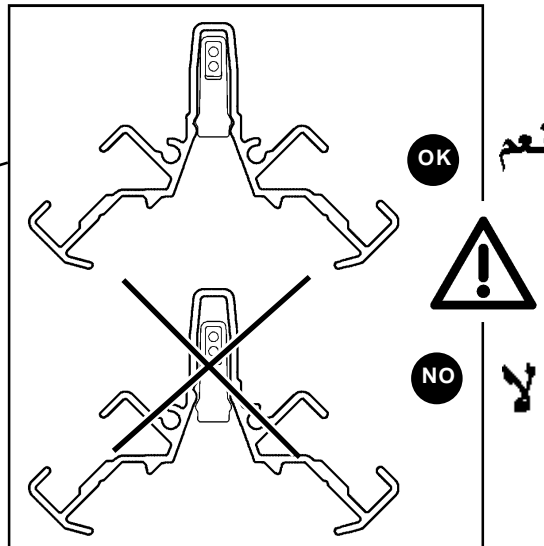
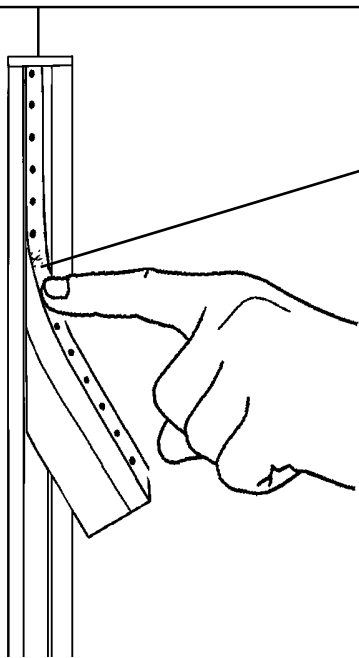
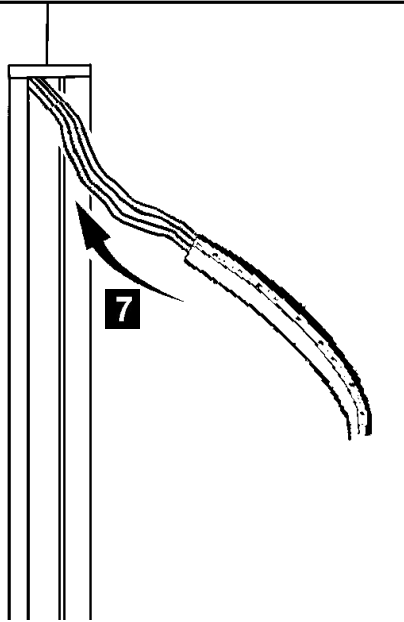

"لا يمكن استبدال الكابل؛ ويتطلب الأمر الاستغناء عن الجهاز، وذلك في حالة تلف الكابل"

I "Il cavo non può essere sostituito; se il cavo è danneggiato l'apparecchio deve essere distrutto"

GB "The cable cannot be replaced. If the cable is damaged, the fixture must be destroyed"

E "El cable no puede sustituirse; si el cable está dañado el aparato debe destruirse"





- I **Attenzione: prodotto sensibile alle cariche elettrostatiche**  
Prendere le dovute precauzioni per la manipolazione e l'installazione del prodotto.
- GB **Attention: Electrostatic-discharge sensitive product.**  
Take suitable precautions when handling and installing the product.
- F **Attention : produit sensible aux décharges électrostatiques**  
Prendre les précautions nécessaires pour la manipulation et l'installation du produit.
- D **Achtung: Produkt empfindlich gegen elektrostatiche Ladungen.**  
Die notwendigen Vorsichtsmaßnahmen für den Umgang mit dem Produkt und seine Installation treffen.
- NL **Let op: product dat gevoelig is voor elektrostatiche lading.**  
Neem de benodigde voorzorgsmaatregelen voor het hanteren en de installatie van het product.
- E **Atención: producto sensible a las descargas electrostáticas**  
Tomar las debidas precauciones para la manipulación y la instalación del producto.
- DK **Bemærk: Produktet er følsomt over for elektrostaticke udladninger.**  
Træf de nødvendige forsigtighedsforanstaltninger i forbindelse med håndtering og installation af produktet.
- N **Forsiktig: Produktet er ømfintlig overfor statisk elektrisitet**  
Ta de nødvendige forholdsregler når du håndterer og monterer produktet
- S **OBS! Produkten är känslig för elektrostatica urladdningar**  
Vidta lämpliga försiktighetsåtgärder vid hantering och installation av produkten.
- RUS **Внимание: изделие является чувствительным к электростатическим зарядам.**  
Примите необходимые меры для перемещения и установки изделия.
- CN **注意: 本产品可能受到静电荷的影响**  
操作和安装产品时必须注意。



- I **Attenzione: prodotto sensibile alle cariche elettrostatiche**  
Prendere le dovute precauzioni per la manipolazione e l'installazione del prodotto.
- GB **Attention: Electrostatic-discharge sensitive product.**  
Take suitable precautions when handling and installing the product.
- F **Attention : produit sensible aux décharges électrostatiques**  
Prendre les précautions nécessaires pour la manipulation et l'installation du produit.
- D **Achtung: Produkt empfindlich gegen elektrostatiche Ladungen.**  
Die notwendigen Vorsichtsmaßnahmen für den Umgang mit dem Produkt und seine Installation treffen.
- NL **Let op: product dat gevoelig is voor elektrostatiche lading.**  
Neem de benodigde voorzorgsmaatregelen voor het hanteren en de installatie van het product.
- E **Atención: producto sensible a las descargas electrostáticas**  
Tomar las debidas precauciones para la manipulación y la instalación del producto.
- DK **Bemærk: Produktet er følsomt over for elektrostaticke udladninger.**  
Træf de nødvendige forsigtighedsforanstaltninger i forbindelse med håndtering og installation af produktet.
- N **Forsiktig: Produktet er ømfintlig overfor statisk elektrisitet**  
Ta de nødvendige forholdsregler når du håndterer og monterer produktet
- S **OBS! Produkten är känslig för elektrostatica urladdningar**  
Vidta lämpliga försiktighetsåtgärder vid hantering och installation av produkten.
- RUS **Внимание: изделие является чувствительным к электростатическим зарядам.**  
Примите необходимые меры для перемещения и установки изделия.
- CN **注意: 本产品可能受到静电荷的影响**  
操作和安装产品时必须注意。



- I **Attenzione: prodotto sensibile alle cariche elettrostatiche**  
Prendere le dovute precauzioni per la manipolazione e l'installazione del prodotto.
- GB **Attention: Electrostatic-discharge sensitive product.**  
Take suitable precautions when handling and installing the product.
- F **Attention : produit sensible aux décharges électrostatiques**  
Prendre les précautions nécessaires pour la manipulation et l'installation du produit.
- D **Achtung: Produkt empfindlich gegen elektrostatiche Ladungen.**  
Die notwendigen Vorsichtsmaßnahmen für den Umgang mit dem Produkt und seine Installation treffen.
- NL **Let op: product dat gevoelig is voor elektrostatiche lading.**  
Neem de benodigde voorzorgsmaatregelen voor het hanteren en de installatie van het product.
- E **Atención: producto sensible a las descargas electrostáticas**  
Tomar las debidas precauciones para la manipulación y la instalación del producto.
- DK **Bemærk: Produktet er følsomt over for elektrostaticke udladninger.**  
Træf de nødvendige forsigtighedsforanstaltninger i forbindelse med håndtering og installation af produktet.
- N **Forsiktig: Produktet er ømfintlig overfor statisk elektrisitet**  
Ta de nødvendige forholdsregler når du håndterer og monterer produktet
- S **OBS! Produkten är känslig för elektrostatica urladdningar**  
Vidta lämpliga försiktighetsåtgärder vid hantering och installation av produkten.
- RUS **Внимание: изделие является чувствительным к электростатическим зарядам.**  
Примите необходимые меры для перемещения и установки изделия.
- CN **注意: 本产品可能受到静电荷的影响**  
操作和安装产品时必须注意。



تحذير: هذا المنتج حساس للشحنات الكهروستاتيكية  
يجب اتخاذ الاحتياطات اللازمة عند التعامل مع المُنتج وتثبيته.

- I **Attenzione: prodotto sensibile alle cariche elettrostatiche**  
Prendere le dovute precauzioni per la manipolazione e l'installazione del prodotto.
- GB **Attention: Electrostatic-discharge sensitive product.**  
Take suitable precautions when handling and installing the product.
- E **Atención: producto sensible a las descargas electrostáticas**  
Tomar las debidas precauciones para la manipulación y la instalación del producto.



تحذير: هذا المنتج حساس للشحنات الكهروستاتيكية  
يجب اتخاذ الاحتياطات اللازمة عند التعامل مع المُنتج وتثبيته.

- I **Attenzione: prodotto sensibile alle cariche elettrostatiche**  
Prendere le dovute precauzioni per la manipolazione e l'installazione del prodotto.
- GB **Attention: Electrostatic-discharge sensitive product.**  
Take suitable precautions when handling and installing the product.
- E **Atención: producto sensible a las descargas electrostáticas**  
Tomar las debidas precauciones para la manipulación y la instalación del producto.



تحذير: هذا المنتج حساس للشحنات الكهروستاتيكية  
يجب اتخاذ الاحتياطات اللازمة عند التعامل مع المُنتج وتثبيته.

- I **Attenzione: prodotto sensibile alle cariche elettrostatiche**  
Prendere le dovute precauzioni per la manipolazione e l'installazione del prodotto.
- GB **Attention: Electrostatic-discharge sensitive product.**  
Take suitable precautions when handling and installing the product.
- E **Atención: producto sensible a las descargas electrostáticas**  
Tomar las debidas precauciones para la manipulación y la instalación del producto.

- I Istruzioni per le operazioni di servizio per l'apparecchio di illuminazione**  
**GB Instructions on luminaire service operations**  
**F Instructions pour les opérations de service du luminaire**  
**D Wartungsanleitung für die Leuchte**  
**NL Instructies voor de onderhoudsoperaties op de verlichtingsarmatuur**  
**E Instrucciones para las operaciones de servicio del aparato de alumbrado**  
**DK Anvisninger i serviceindgreb på belysningsarmatur**  
**N Anvisninger for betjening av lysapparatet**  
**S Instruktioner för användning av belysningsanordningen**  
**RUS Инструкция по эксплуатации осветительного прибора**  
**CN 照明装置检修操作说明**

**Sostituire la lampada parzialmente esausta**  
 Replace the partly exhausted lamp  
 Remplacer la lampe partiellement épuisée  
 Die teilweise erschöpfte Lampe austauschen  
 Vervang de gedeeltelijk lege lamp  
 Sustituir la lámpara parzialmente agotada  
 Udskift den delvist udtjente pære  
 Skifte ut den delvis utbrente lyspæren  
 Byt ut den delvis förbrukade lampan  
 Замена частично отработанной лампочки  
 更换部分老化的灯泡



**Spegnimento**  
 Switch it off  
 Extinction  
 Ausschaltung  
 Uitschakeling  
 Apagado  
 Slukning  
 Slukking  
 Släckning  
 Выключение  
 关灯

**Interrompere l'alimentazione dell'apparecchio**  
 Cut the power supply to the luminaire  
 Couper l'alimentation du luminaire  
 Stromversorgung der Leuchte unterbrechen  
 Onderbreek de voeding van het apparaat  
 Interrumpir la alimentación del aparato  
 Afbryd armaturets strømforsyning  
 Avbryte strømtilførselen til apparatet  
 Koppla från anordningens strömförsörjning  
 Отключить электропитание прибора  
 中断装置供电

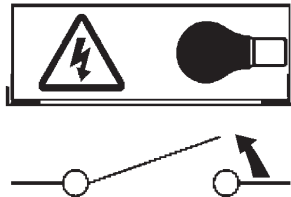

**Aprire l'apparecchio**  
 Open the fixture  
 Ouvrir le luminaire  
 Das Gerät öffnen  
 Open het apparaat  
 Abrir el aparato  
 Åbn armaturet  
 Åpne apparatet  
 Öppna anordningen  
 Раскрыть прибор  
 打开装置

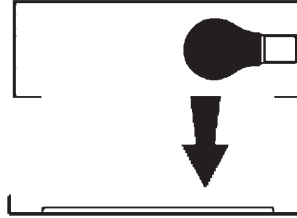

**Rimuovere la lampada esausta**  
 Remove the exhausted lamp  
 Retirer la lampe épuisée  
 Die alte Lampe entnehmen  
 Verwijder de lege lamp  
 Quitar la lámpara agotada  
 Tag den udtjente pære ud  
 Fjerne den utbrente lyspæren  
 Ta bort den förbrukade lampan  
 Вынуть старую лампочку  
 取出老化的灯泡

**Portarla in un centro di riciclaggio**  
 Carry it to a recycling centre  
 La porter dans une déchetterie pour son recyclage  
 Ordnungsgemäß entsorgen  
 Breng de lamp naar een recyclingcentrum  
 Llevarla a un centro de reciclaje  
 Aflever den på en genbrugsstation  
 Lever den til en miljøstasjon  
 Lämna in den till en återvinningsanläggning  
 Сдать ее в пункт приема утильсырья  
 将其送往回收中心



**Inserire la nuova lampada**  
 Introduce the new lamp  
 Installer la lampe neuve  
 Die neue Lampe einsetzen  
 Doe de nieuwe lamp op zijn plek  
 Montar la nueva lámpara  
 Sæt den nye pære i  
 Sette i den nye pæren  
 Sätt i den nya lampan  
 Вставить новую лампочку  
 装入新灯泡

**Inserire la nuova lampada nel portalampada**  
 Fit the new lamp into the socket  
 Installer la nouvelle lampe dans le support de lampe  
 Die neue Lampe in den Sockel einsetzen  
 Doe de nieuwe lamp in de lamphouder  
 Montar la nueva lámpara en el portalámpara  
 Sæt den nye pære i fatningen  
 Sette den nye pæren inn i lampeholderen  
 Sätt i den nya lampan i lamphållaren  
 Вставить новую лампочку в патрон  
 将新灯泡插入灯泡架中



**Riposizionare ottica**  
 Re-place the optic  
 Remettre l'optique à sa place  
 Die Optik wieder einsetzen  
 Doe de optiek weer op zijn plaats  
 Volver a montar la óptica  
 Sæt den optiske enhed på plads  
 Innstille linsen  
 Flytta om optiken  
 Отрегулировать линзы  
 重新定位光头



**Effettuare prova di funzionamento**  
 Perform operative test  
 Procéder à un essai de fonctionnement  
 Eine Funktionsprüfung durchführen  
 Controleer de correcte werking  
 Hacer una prueba de funcionamiento  
 Afprøv funktionen  
 Prøve om den fungerer  
 Utför funktionstest  
 Выполнить проверку исправности работы  
 执行功能测试



**I Istruzioni per la pulizia dell'apparecchio di illuminazione**  
**GB Instructions on luminaire cleaning operations**  
**F Instructions pour le nettoyage du luminaire**  
**D Anweisungen zur Reinigung der Leuchte**  
**NL Instructies voor de reiniging van de verlichtingsarmatuur**  
**E Instrucciones para limpiar el aparato de alumbrado**  
**DK Anvisninger i rengøring af belysningsarmaturet**  
**N Anvisninger for rengjøring av lysapparatet**  
**S Instruktioner för rengöring av belysningsanordningen**  
**RUS Инструкции по чистке осветительного прибора**  
**CN 照明装置清洁说明**

**Pulire l'apparecchio**  
**Clean the fixture**  
**Nettoyer le luminaire**  
**Das Gerät reinigen**  
**Reinig het apparaat**  
**Limpiar el aparato**  
**Rengør armaturet**  
**Rengjøre apparatet**  
**Rengör anordningen**  
**Чистка прибора**  
**清洁装置**



**Spegnimento**  
**Switch it off**  
**Extinction**  
**Ausschaltung**  
**Uitschakeling**  
**Apagado**  
**Slukning**  
**Slukking**  
**Släckning**  
**Выключение**  
**关灯**

**Interrompere l'alimentazione dell'apparecchio**  
**Cut the power supply to the luminaire**  
**Couper l'alimentation du luminaire**  
**Stromversorgung der Leuchte unterbrechen**  
**Onderbreek de voeding van het apparaat**  
**Interrumpir la alimentación del aparato**  
**Afbryd armaturets strømforstyrning**  
**Avbryt strømtilførselen til apparatet**  
**Koppla från anordningens strömförsörjning**  
**Отключить электропитание прибора**  
**中断装置供电**



**Spolverare l'ottica esterna**  
**Remove dust from the external optic**  
**Dépoussiérer l'optique extérieure**  
**Die externe Optik abstauben**  
**Stof de externe optiek af**  
**Quitar el polvo de la óptica exterior**  
**Tør støvet af den udvendige optiske enhed**  
**Fjerne støv fra den eksterne lysenheden**  
**Damma av den yttre optiken**  
**Вытереть пыль с внешней стороны линз**  
**为外侧光头掸尘**



**Lavare l'ottica esterna**  
**Wash the external optic**  
**Laver l'optique extérieure**  
**Die externe Optik waschen**  
**Was de externe optiek**  
**Lavar la óptica exterior**  
**Vask den udvendige optiske enhed**  
**Vaske den eksterne lysenheden**  
**Rengör den yttre optiken**  
**Вымыть линзы с внешней стороны**  
**清洁外光头**



**Rimuovere l'ottica**  
**Remove the optic**  
**Retirer l'optique**  
**Die Optik abnehmen**  
**Verwijder de optiek**  
**Quitar la óptica**  
**Tag den optiske enhed af**  
**Fjerne lysenheden**  
**Ta bort optiken**  
**Снять линзы**  
**取下光头**



**Pulire la parte interna dell'apparecchio di illuminazione**  
**Clean the inside of the fixture**  
**Nettoyer l'intérieur du luminaire**  
**Die Innenseite der Leuchte reinigen**  
**Reinig de binnenzijde van de verlichtingsarmatuur**  
**Limpiar el interior del aparato de alumbrado**  
**Rengør belysningsarmaturets indvendige dele**  
**Rengjøre lysapparatet innvendig**  
**Rengör belysningsanordningen invändigt**  
**Протереть осветительный прибор изнутри**  
**清洁照明装置内部**



**Riposizionare ottica**  
**Re-place the optic**  
**Remettre l'optique à sa place**  
**Die Optik wieder einsetzen**  
**Doe de optiek weer op zijn plaats**  
**Volver a montar la óptica**  
**Sæt den optiske enhed på plads**  
**Innstille linsen**  
**Flytta om optiken**  
**Отрегулировать линзы**  
**重新定位光头**



**Effettuare prova di funzionamento**  
**Perform operative test**  
**Procéder à un essai de fonctionnement**  
**Eine Funktionsprüfung durchführen**  
**Controleer de correcte werking**  
**Hacer una prueba de funcionamiento**  
**Afprøv funktionen**  
**Prøve om den fungerer**  
**Utför funktionstest**  
**Выполнить проверку исправности работы**  
**执行功能测试**



- I** Istruzioni per il fine vita e lo smaltimento dei componenti  
**GB** Instructions on end-of-life and component disposal  
**F** Instructions pour la gestion des composants en fin de vie et leur mise au rebut  
**D** Anweisungen zur Entsorgung der Leuchtenkomponenten  
**NL** Instructies voor het verwijderen van de armatuur en het recyclen van de onderdelen  
**E** Instrucciones para el final de vida y la eliminación los componentes  
**DK** Anvisninger i udtjent armatur og bortskaffelse af komponenter  
**N** Anvisninger for endt levetid og avfallsbehandling av delene  
**S** Instruktioner vid bortskaffning och kassering av komponenter  
**RUS** Инструкции по утилизации прибора и его комплектующих по окончании его срока службы  
**CN** 寿命期结束与零件废弃处置说明

<p>Spegnimento Switch it off Extinction Ausschaltung Uitschakeling Apagado Slukning Slukking Släckning Выключение 关灯</p> <p>Interrompere l'alimentazione dell'apparecchio Cut the power supply to the luminaire Couper l'alimentation du luminaire Stromversorgung der Leuchte unterbrechen Onderbreek de voeding van het apparaat Interrompirla alimentación del aparato Afbryd armaturets strømforsyning Avbryt strømtilførselen til apparatet Koppla från anordningens strömförsörjning Отключить электропитание прибора 中断装置供电</p> 	<p>Rimuovere la/e lampada/e per la dismissione Remove the lamp(s) for decommissioning Retirer la(les) lampe(s) pour sa(leur) mise au rebut Die Lampe/n ordnungsgemäß entsorgen Verwijder de lamp(en) voor het recyclen Quitar la(s) lámpara(s) para el desecho Tag pæren/pærerne ud til bortskaffelse Fjerne lampen/-e som skal kastes Ta bort lampan/-orna för bortskaffningen Вынуть лампочку/и для утилизации прибора 取出需要丢弃的灯泡</p> 	<p>Rimuovere la batteria per la dismissione Remove the battery for decommissioning Retirer la batterie pour sa mise au rebut Die Batterie ordnungsgemäß entsorgen Verwijder de batterij voor het recyclen Quitar la batería para el desecho Tag batteriet ud til bortskaffelse Fjerne batteriet som skal kastes Ta bort batteriet för bortskaffningen Вынуть батарейку для утилизации прибора 取出需要丢弃的电池</p> 	<p>Rimuovere l'apparecchio per la dismissione Remove the fixture for decommissioning Enlever le luminaire pour sa mise au rebut Das Gerät ordnungsgemäß entsorgen Verwijder het apparaat voor het recyclen Quitar el aparato para el desecho Tag armaturet ud til bortskaffelse Fjerne apparatet som skal kastes Ta bort anordningen för bortskaffningen Снять прибор для утилизации 取出需要丢弃的装置</p> 
---	--	--	--

<p>Inviare i materiali ad un centro di raccolta RAEE Send the materials to a WEEE collection centre Envoyer les matériaux dans une déchetterie DEEE Die Materialien in einem WEEE-Zentrum entsorgen Zend de materialen naar een recyclingscentrum voor de AEEA Enviar los materiales a un centro de recogida RAEE Afløver materialerne på et indsamlingscenter for elektronisk udstyr Sende materialene til en miljøstasjon for resirkulering av EE-avfall Skicka materialet till en RAEE uppsamlingscentral Сдать материалы в пункт приема утильсырья 将材料送往电气和电子垃圾回收中心</p> 			
--	--	--	--