

iGuzzini

TECNICA PRO

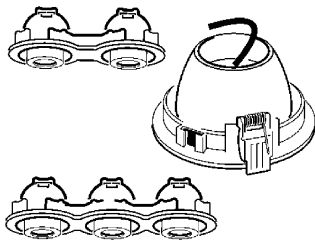

ATTENZIONE:

LA SICUREZZA DELL'APPARECCHIO E' GARANTITA SOLO CON L'USO APPROPRIATO DELLE SEGUENTI ISTRUZIONI; PERTANTO E' NECESSARIO CONSERVARLE.

WARNING:

THE SAFETY OF THIS FIXTURE IS GUARANTEED ONLY IF YOU COMPLY WITH THESE INSTRUCTIONS; REMEMBER TO CONSERVE IN A SAFE PLACE.

ATTENTION:

LA SECURITE DEL'APPAREIL N'EST GARANTIE QU'EN CAS D'UTILISATION CORRECTE DES INSTRUCTIONS SUIVANTES; IL FAUT PAR CONSEQUENT LES CONSERVER.

ACHTUNG:

DIE SICHERHEIT DES GERÄTES WIRD NUR DURCH SACHGEMÄSSE BEFOLGUNG NACHSTEHENDER ANWEISUNGEN GEWÄHRLEISTET; IHRE AUFBEWAHRUNG IST DESHALB SEHR WICHTIG.

OPGELET:

DE VEILIGHEID VAN DI ATOESTEL IS SLECHTS DAN GEGARANDEERD ALS INDIEN DE VOLGENDE INSTRUCTIES STRIKT WORDEN TOEGEPAST; DAAROM MOET MEN ZE OOK BEWAREN.

ATENCION:

LA SEGURIDAD DEL APARATO SE GARANTIZA SOLO CUMPLIENDO CUIDADOSAMENTE LAS SIGUIENTES INSTRUCCIONES; POR ELLO, ES NECESARIO CONSERVARLAS.

BEMÆRK:

SIKKERHEDEN VED BRUG AF ARMATURET KAN KUN GARANTERES, HVIS DISSE ANVISNINGER FØLGES; SØRG DERFOR FOR AT GEMME DEM.

ADVARSEL:

SIKKERHETEN TIL DETTE APPARATET GARANTERES KUN HVIS DU OVERHOLDER DISSE INSTRUKSJONENE; HUSK Å OPPBEVARE DEM PÅ ET TRYGT STED.

OBSERVERA!

UTRUSTNINGENS SÄKERHET KAN ENDAST GARANTERAS OM DESSA ANVISNINGAR RESPEKTERAS I DETALJ. SPARA DÄRFÖR DESSA ANVISNINGAR FÖR FRAMTIDA KONSULTATION.

ВНИМАНИЕ:

МЫ ГАРАНТИРУЕМ БЕЗОПАСНУЮ ЭКСПЛУАТАЦИЮ ИЗДЕЛИЯ ТОЛЬКО ПРИ СОБЛЮДЕНИИ СЛЕДУЮЩИХ ИНСТРУКЦИЙ; С ЭТОЙ ЦЕЛЬЮ НЕОБХОДИМО СОХРАНИТЬ ДАННУЮ БРОШЮРУ.

警告:

为确保该装置安全，请遵守操作指示；并于安全场所放置。

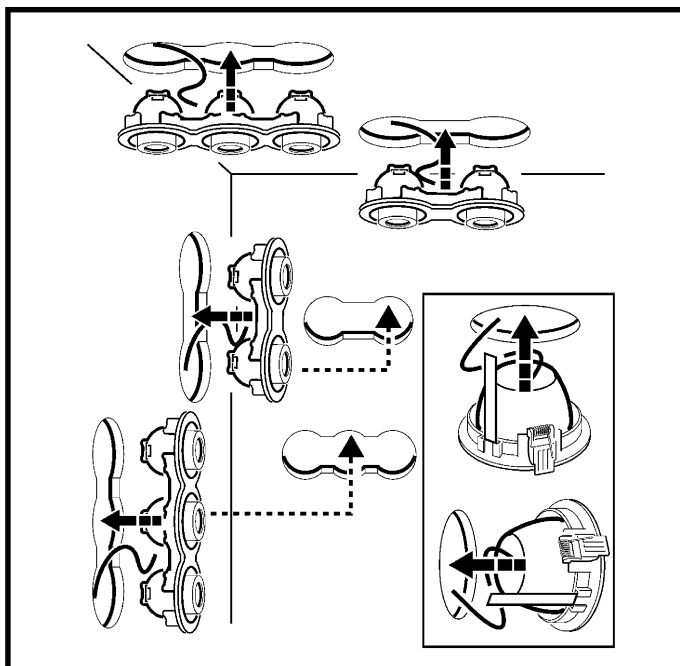
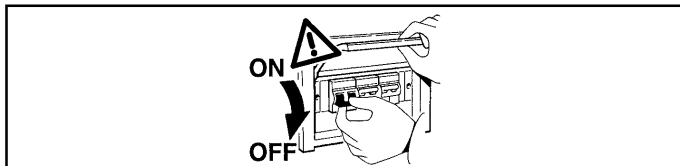
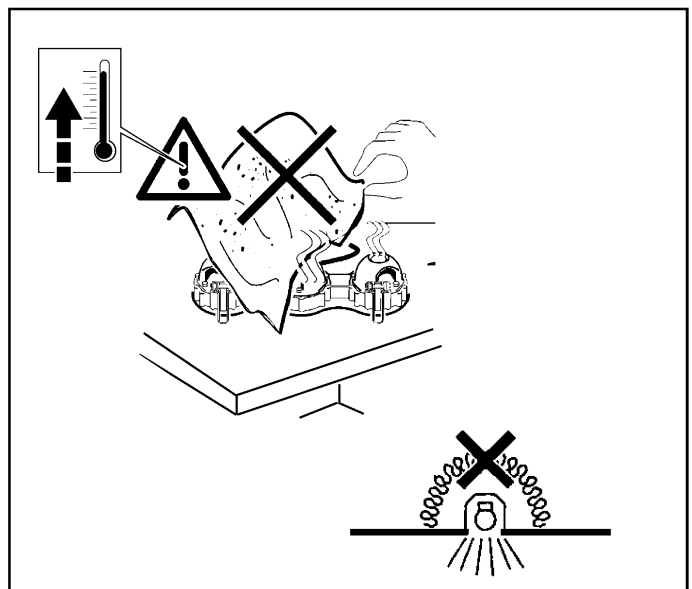
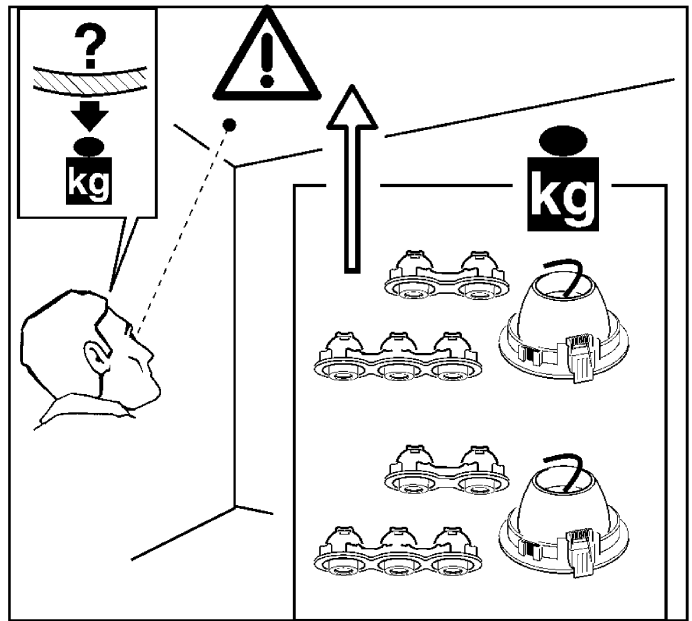
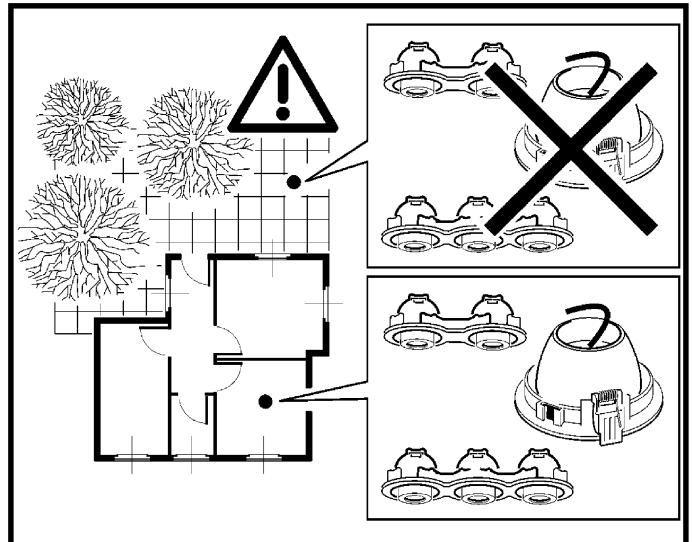

- I N.B.: Apparecchi non idonei ad essere coperti di materiale termicamente isolante
- GB N.B.: Fixtures not suitable to be covered in thermally-insulating material.
- F N.B.: Appareils ne pouvant pas être couverts de matériau d'isolation thermique
- D N.B.: Geräte nicht geeignet, um mit wärmeisolierendem Material abgedeckt zu werden
- NL N.B.: Deze apparaten zijn niet geschikt om te worden bedekt met thermisch isolerend materiaal
- E NOTA: Aparatos no aptos para ser cubiertos de material térmicamente aislante
- DK N.B.: Armaturerne må ikke dækkes af varmeisolerende materiale.
- N N.B.: Apparatene passer ikke til å dekkes av termoisolerende materialer.
- S OBS! Utrustningen får inte täckas över med värmeisolerande material
- RUS Приборы, непригодные для покрытия термоизоляционным материалом.
- CN 灯具不适宜用隔热材料加以覆盖!

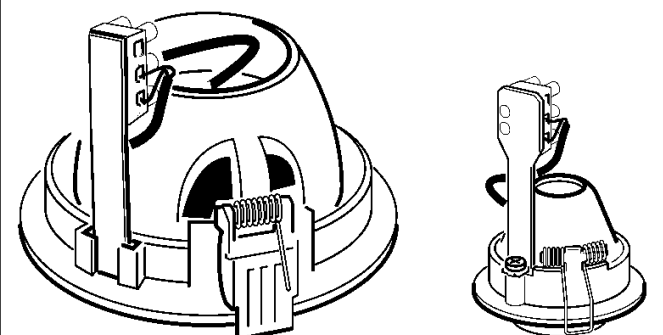
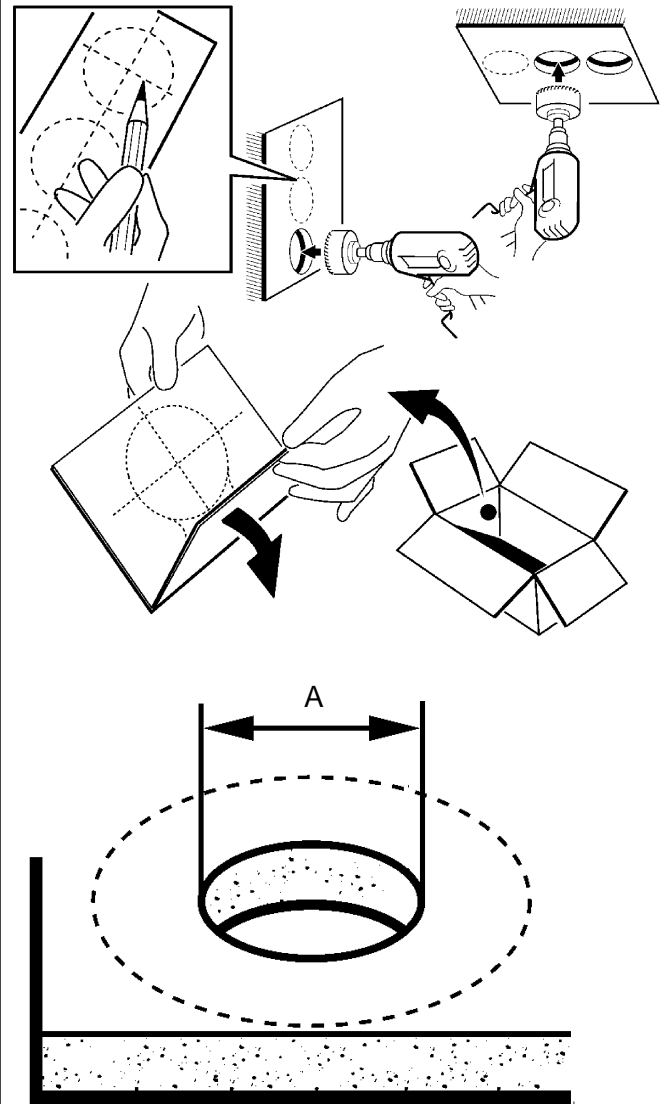
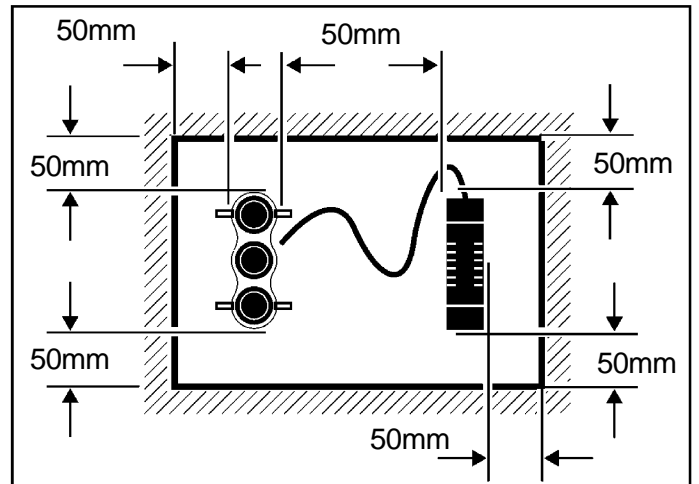
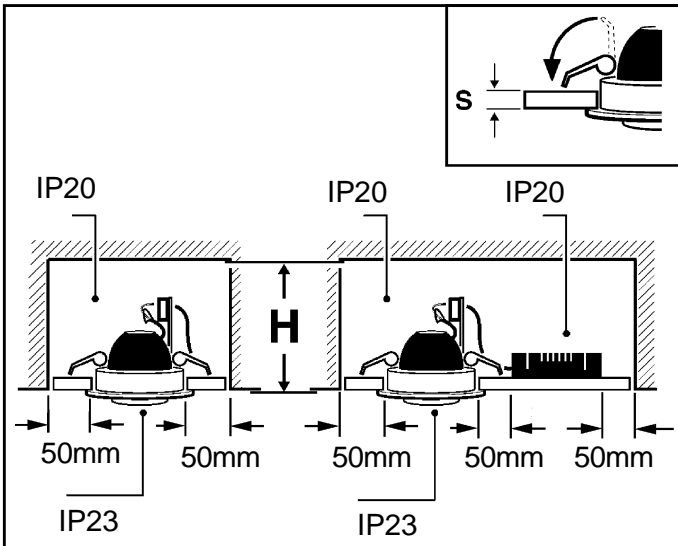
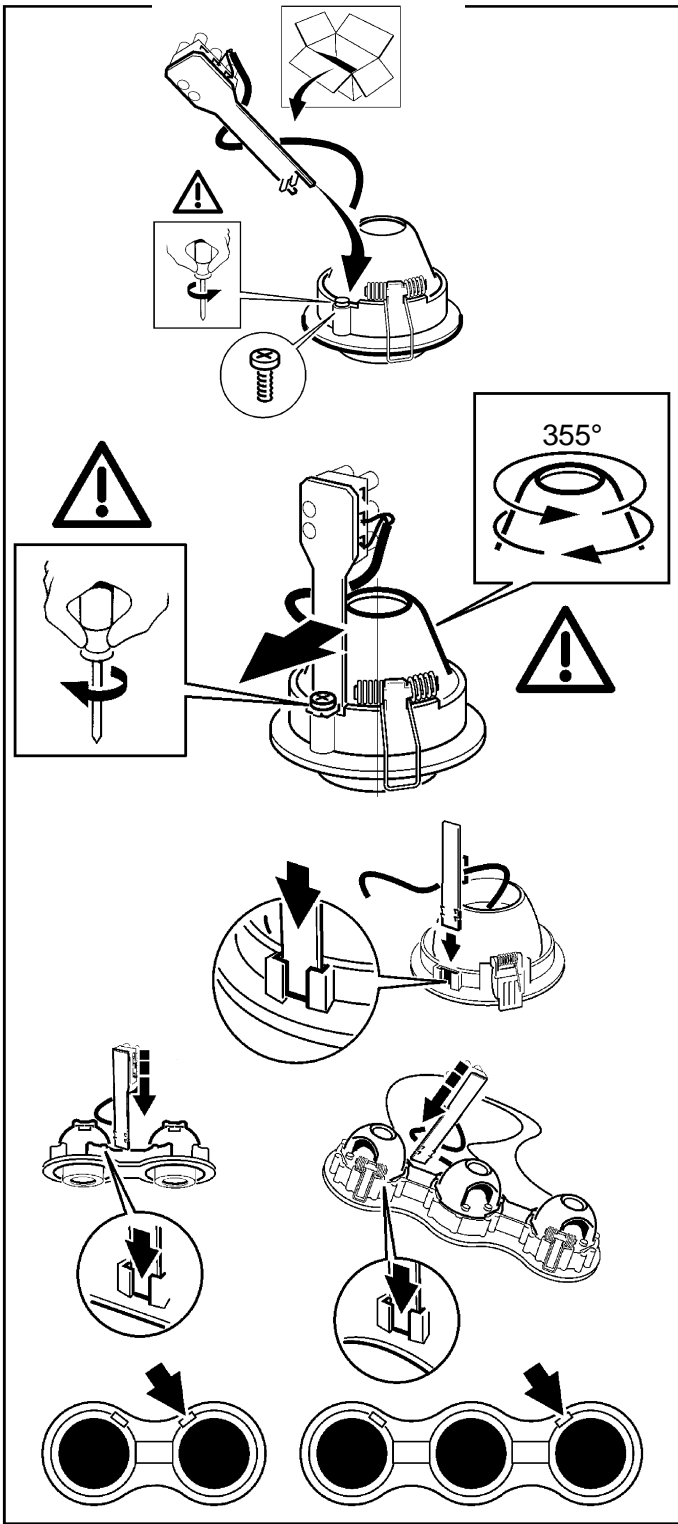

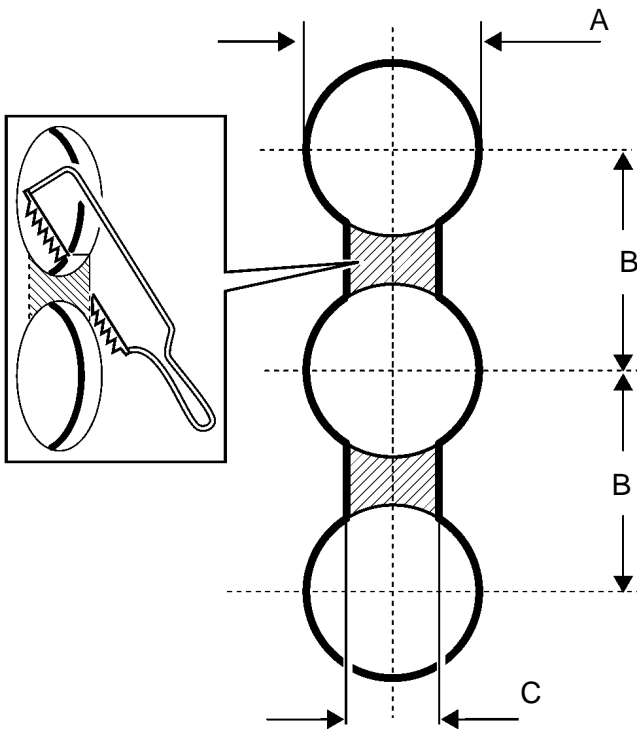
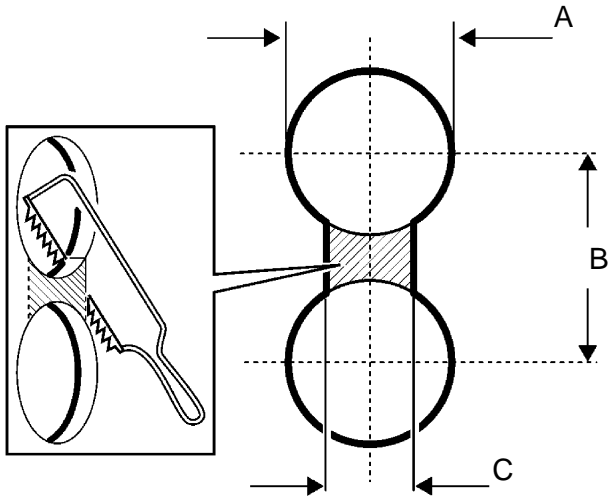

ART.	A mm	B mm	C mm	S mm	H mm
MS41 - MS42 MS43 - MS44 MS50 - MS51 MS52 - MS53 MS54 - MS55 MS56 - MS57	64	70,6	35	1 ÷ 20	85
MS41 - MS42 MS43 - MS44 + 6993	64	/	/	1 ÷ 20	115
MS45 - MS46 MS47 - MS48 MS58 - MS59 MS60 - MS61 MS63 - MS64 MS65 - MS66	114	123,5	65	1 ÷ 20	85
MS45 - MS46 MS47 - MS48 + 6993	114	/	/	1 ÷ 20	85

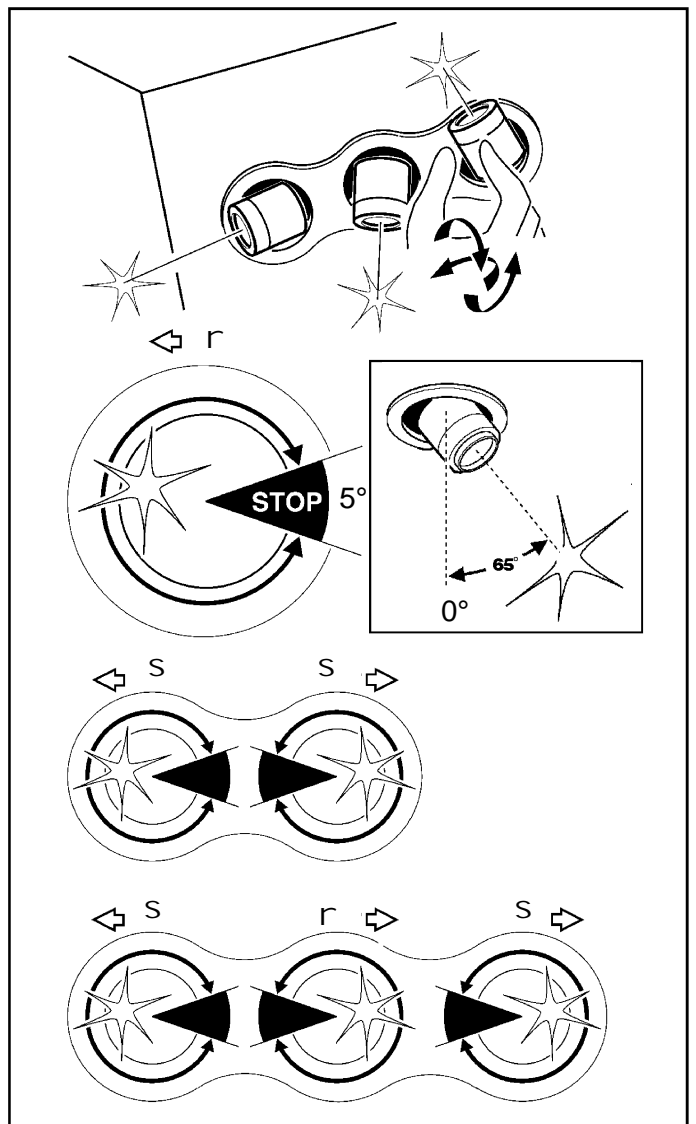
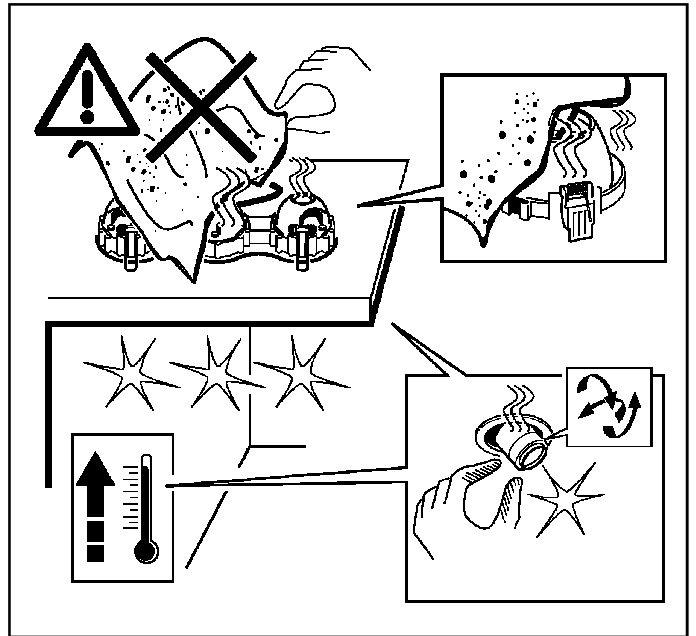

ART.	MS41-MS42-MS43 MS44-MS45-MS46 MS47-MS48	MS51-MS52-MS53 MS54-MS55-MS56 MS57	MS58-MS59- MS60-MS61 MS63-MS64 MS65-MS66
r	355°	355°	355°
S	/	355°	220°

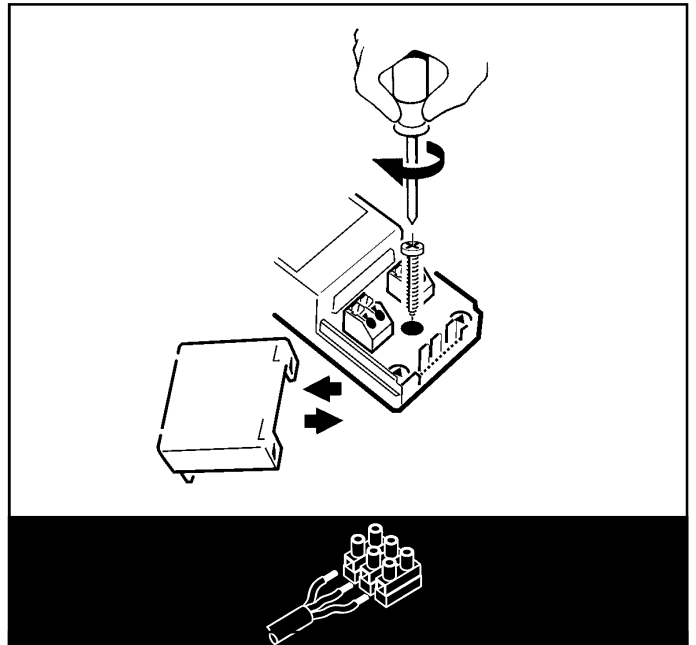
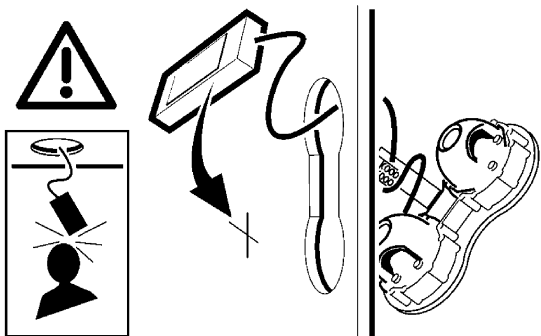
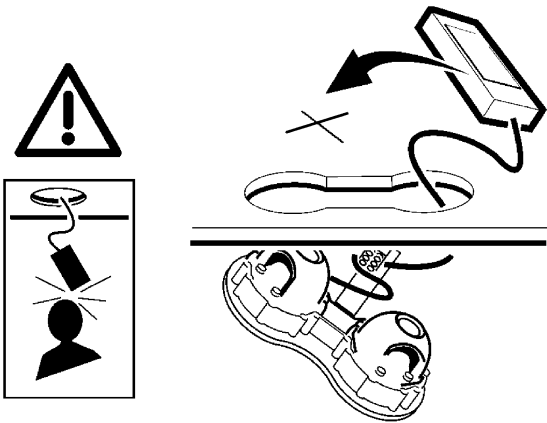
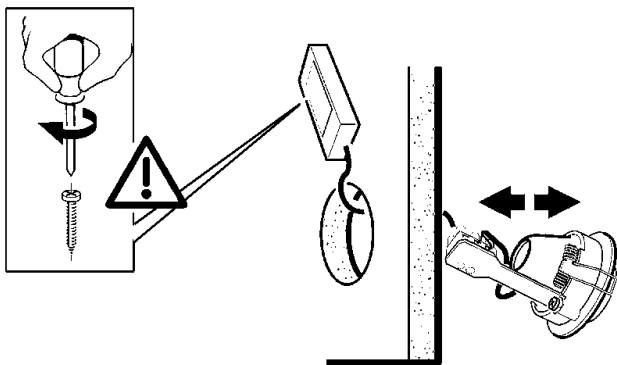
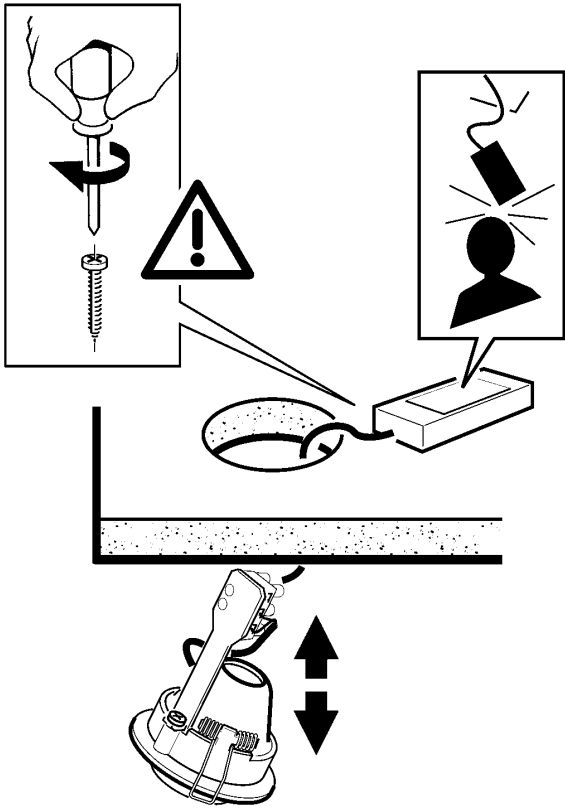

ERC

art. 6993

CAVONERO
BLACK CABLE
CABLE NOIRE
SCHWARZE KABEL
ZWARTE KABEL
CABLE NEGRO
SORTLEDNING
SVART KABEL
SVART KABEL
ЧЕРНЫЙ ПРОВОД
黑色电缆

CAVO ROSSO
RED CABLE
CABLE ROUGE
ROTES KABEL
RODE KABEL
CABLE ROJO
RØDLEDNING
RØD KABEL
RÖD KABEL
КРАСНЫЙ ПРОВОД
OD 红色电缆

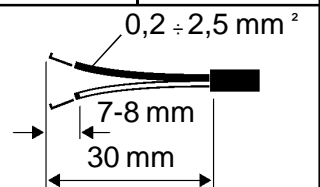
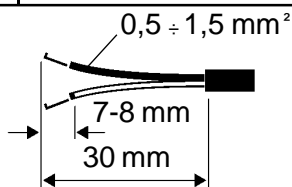
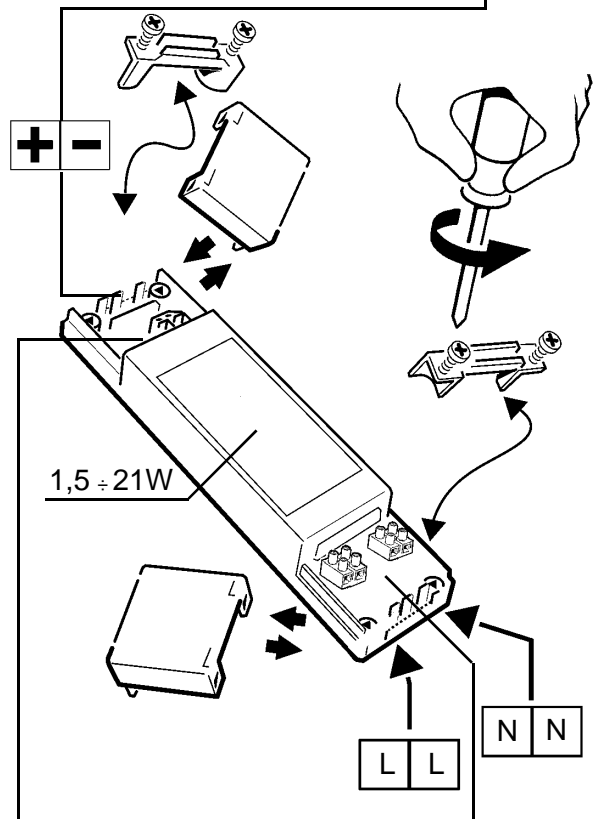

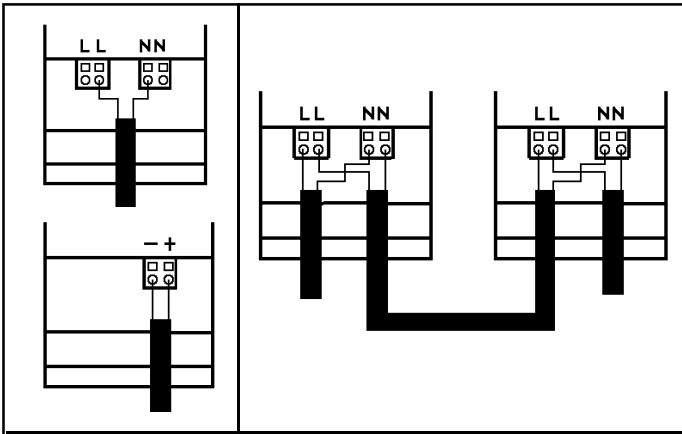

ALIMENTAZIONE
 POWER SUPPLY
 ALIMENTATION
 ALIMENTATION
 EINSPEISUNG
 STROOMVERZORGING
 ALIMENTACION
 STRØMFORSYNING
 STRØMFORSYNING
 ELFÖRSÖRJNING
 ЭЛЕКТРОПИТАНИЕ
 电源

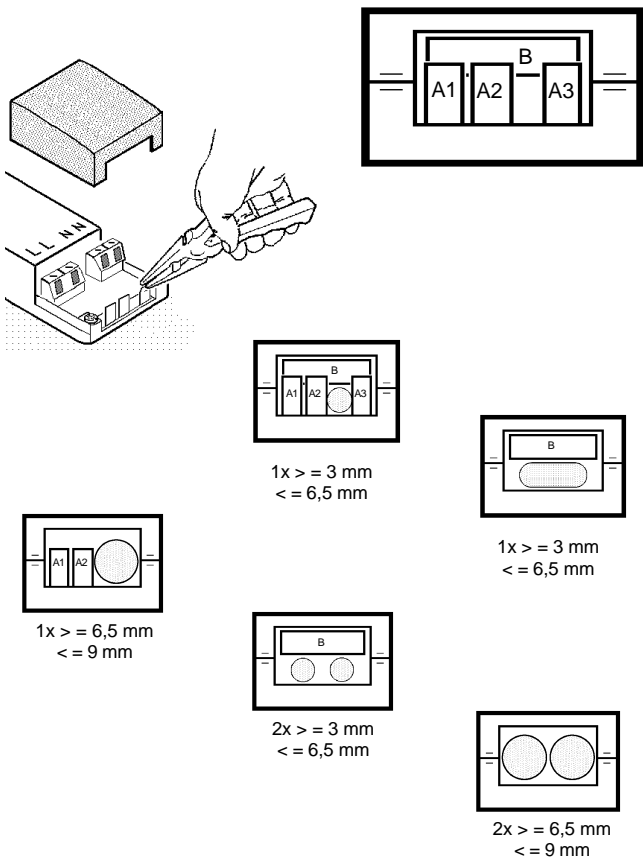
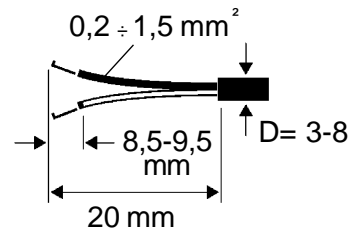
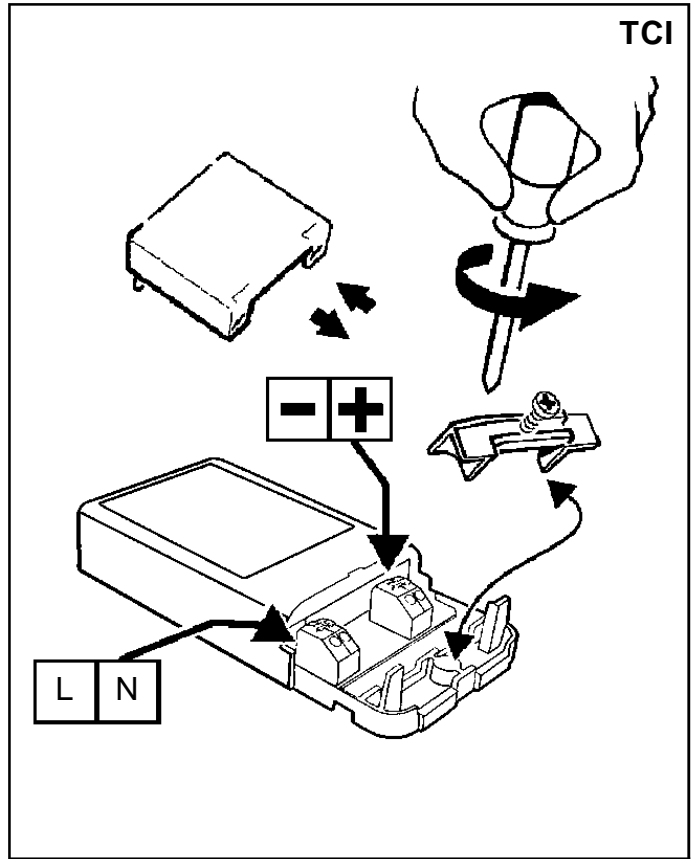
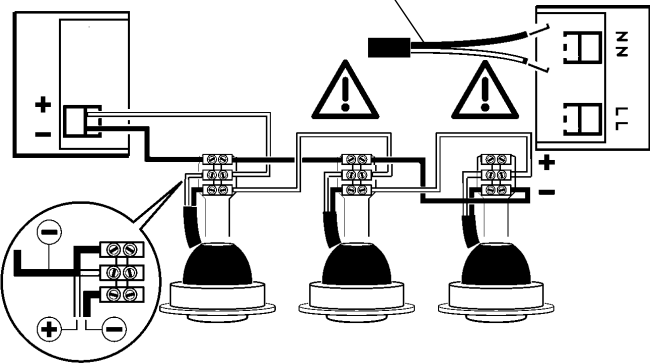

	1LED	Min - 1LED Max - 9LED
	3LED	
	2LED	
	3LED	

- I Le prestazioni e la sicurezza dell'apparecchio sono garantite soltanto per oscillazioni della corrente del $\pm 5\%$ rispetto al valore nominale.
La conformità alla norma è garantita soltanto utilizzando alimentatori iGuzzini (art.: 6993) od equivalenti di tipo SELV che rispondano alle vigenti norme C.E.I.
- GB The performance level and safety of the lighting fixture are only guaranteed for oscillations of $\pm 5\%$ in the current, in relation to the nominal value.
Conformity with the standard is guaranteed only if either iGuzzini ballasts (item code 6993) or equivalent SELV type ballasts which comply with current C.E.I. regulations are used.
- F Les performances et la sécurité de l'appareil ne sont assurées que pour des oscillations de courant de $\pm 5\%$ par rapport à la valeur nominale.
La conformité à la norme n'est assurée qu'en cas d'utilisation de ballasts iGuzzini (réf. : 6993) ou équivalents type SELV conformes aux normes C.E.I.
- D Die Leistungen und die Sicherheit des Geräts sind nur für vom Vorschaltgerät abgehende Spannungsschwankungen von $\pm 5\%$ in Bezug auf den Nennwert gewährleistet.
Die Übereinstimmung mit den Vorschriften ist nur bei Verwendung von iGuzzini-Netzteilen (Art.: 6993) oder gleichwertigen des Typs SELV, die den gültigen CE-Bestimmungen entsprechen, gewährleistet.
- NL De prestaties en de veiligheid van het apparaat zijn alleen gegarandeerd voor spanningsvariaties van $\pm 5\%$ ten opzichte van de nominale waarde.
De conformiteit aan de norm wordt alleen gegarandeerd als u iGuzzini voorschakelapparaten gebruikt (art.: 6993) of overeenkomstige, van het type SELV, die aan de geldende C.E.I. normen voldoen.
- E Las prestaciones y la seguridad del aparato están garantizada solamente con oscilaciones de la corriente del $\pm 5\%$ respecto al valor nominal.
La conformidad a la norma se garantiza solamente con el uso de alimentadores iGuzzini (art. 6993) o equivalentes de tipo SELV que cumplen las normas vigentes C.E.I.
- DK Armaturets ydelse og sikkerhed kan kun garanteres ved strømsvingning på $\pm 5\%$ i forhold til den nominelle værdi.
Opfyldelse af reglerne garanteres kun ved brug af strømforsyningsenheder fra iGuzzini (art.: 6993) eller tilsvarende af typen SELV, der opfylder kravene i C.E.I.-standarderne.
- N Ytelsenivået og sikkerheten til lysarmaturen kan kun garanteres for svingninger på $\pm 5\%$ i strømmen, i forhold til nominell verdi.
Samsvar med forskriften garanteres bare ved bruk av transformatorer fra iGuzzini (art.: 6993) eller tilsvarende av typen SELV som tilsvarende gjeldende forskrifter C.E.I.
- S Utrustningens prestanda och säkerhet garanteras endast vid en strömoscillation på $\pm 5\%$ i förhållande till nominellt värde.
Överensstämmelse med standard garanteras endast genom att använda nätaggregat av typ iGuzzini (art.: 6993) eller motsvarande av typ SELV som överensstämmer med gällande C.E.I.-standard.
- RUS **Соответствие нормативу гарантируется только при использовании блоков питания iGuzzini (арт.: 6993) или аналогичных типа SELV, отвечающих действующим нормативам ЕЭС.**
- CN **只有在使用的iGuzzini(6993产品)或者与之相同的SELV种类的符合C.E.I. 法规的供电情况下, 产品的合格性才能够被保证。**

- I Per progetti d'impianto personalizzati l'azienda iGuzzini fornisce, previa documentazione necessaria, i dati relativi al numero dei prodotti installabili e la lunghezza dei cavi, in funzione dell'alimentatore e del tipo di cavo utilizzato.
- GB For customised installation projects iGuzzini is able to supply - accompanied by the necessary documentation - the details of the number of installable products and the length of the cables based on the ballast and type of cable used.
- F Pour des projets d'installation personnalisés, veuillez transmettre la documentation nécessaire à l'entreprise iGuzzini, qui s'occupera d'indiquer le nombre de produits à installer ainsi que le longueur des câbles, en fonction du ballast et du type de câble utilisés.
- D Für personalisierte Anlagenprojekte liefert das Unternehmen iGuzzini nach Vorlage der erforderlichen Dokumentation die Angaben bezüglich der Anzahl der installierbaren Leuchten sowie die Kabellänge in Abhängigkeit vom Vorschaltgerät und von der Art des verwendeten Kabels.
- NL Na ontvangst van het benodigde documentatiemateriaal kan het bedrijf iGuzzini bij gepersonaliseerde installatie-ontwerpen informatie verschaffen betreffende het aantal installeerbare producten en de lengte van de kabels voor het voorschakelapparaat, aan de hand van het type kabel wat gebruikt zal worden.
- E Para proyectos personalizados y previo conocimiento de la documentación necesaria, iGuzzini puede suministrar datos sobre el número de productos a instalar y la longitud de los cables en función de alimentador y tipo de cable utilizado.
- DK Ved skræddersyede anlæg fremsender iGuzzini dokumentation med alle oplysninger vedrørende antallet af produkter, der kan installeres, og kabellængde, alt efter typen af strømforsyning og kabel.
- N For spesialtilpassede installasjonsprosjekter er iGuzzini i stand til å levere - sammen med den nødvendige dokumentasjonen - detaljene på installerbare produkter og lengden på kablene basert på ballast og type kabel som brukes.
- S För kundanpassade installationer tillhandahåller iGuzzini (efter nödvändig dokumentation) data angående antalet produkter som kan installeras och kablarnas längd, beroende på typen av strömförsörjningsanordning och kabel som används.
- RUS Для индивидуальных проектов осветительных систем, после получения всей необходимой документации заказчика, Компания iGuzzini предоставляет сведения о количестве изделий, которые могут быть установлены, и о длине проводов в зависимости от блока питания и от типа используемого провода.
- CN 对于自定义设备项目, iGuzzini公司在获得必要的文件后, 可根据使用的供电设备及电缆种类提供可安装产品数量和电缆长度的数据。

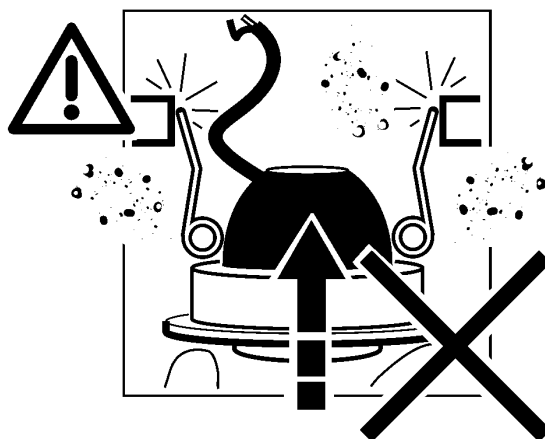
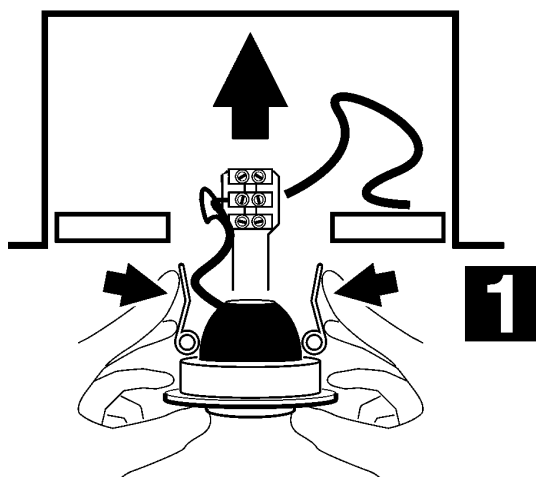
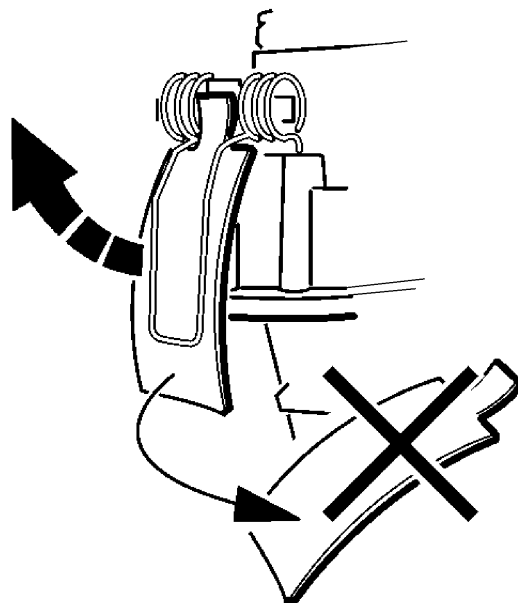

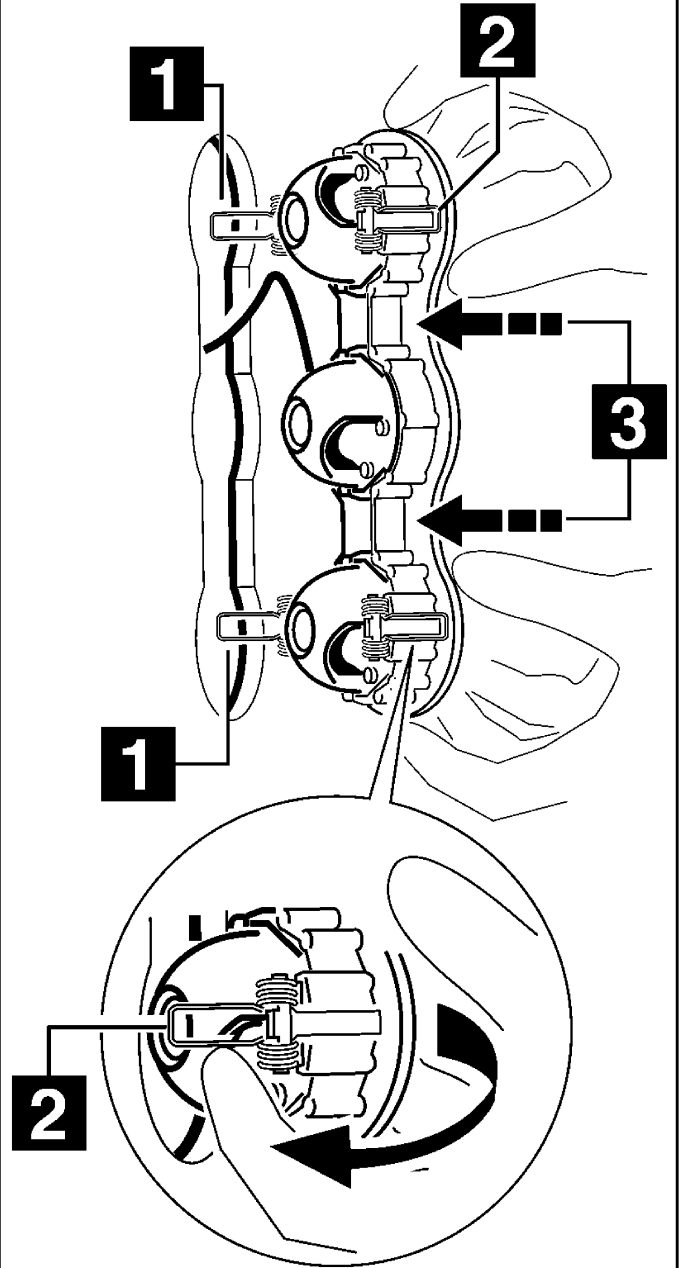
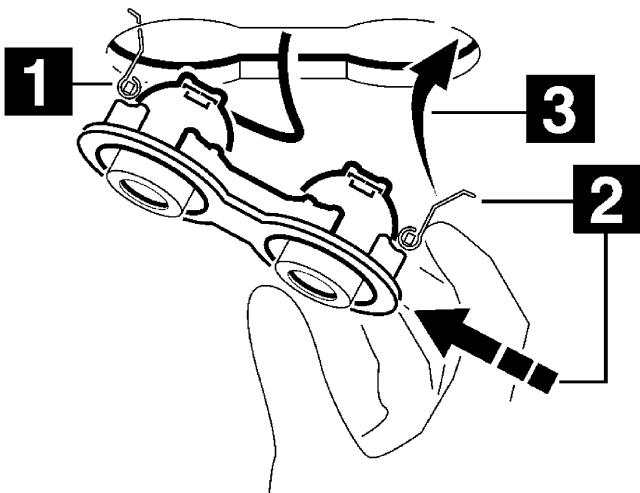
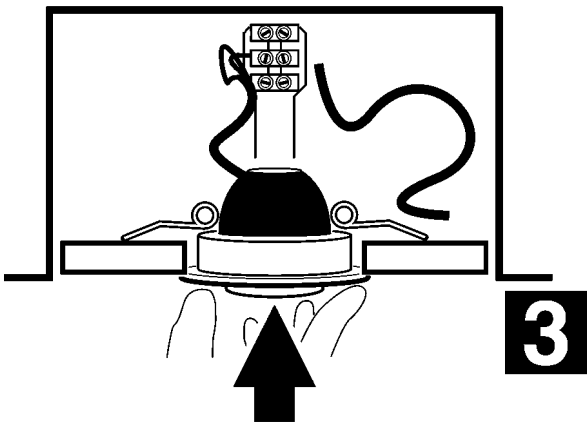
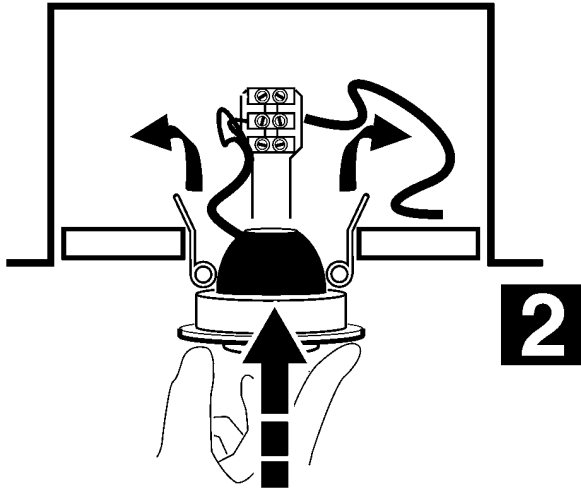

art. 6910 - 6936 - MW57 - MW58

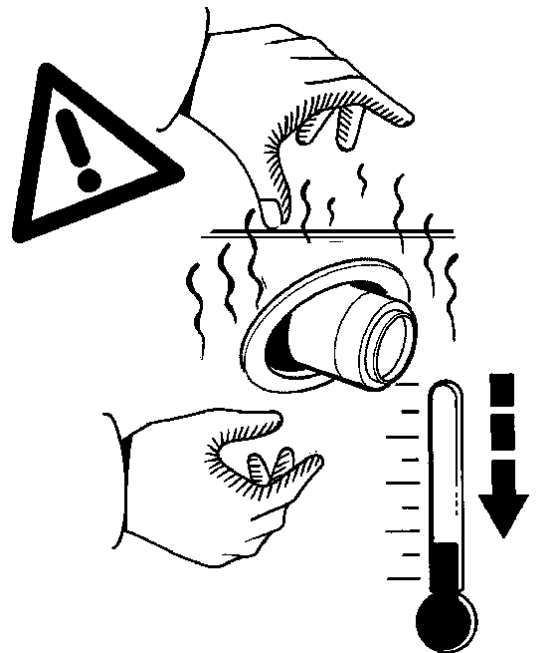

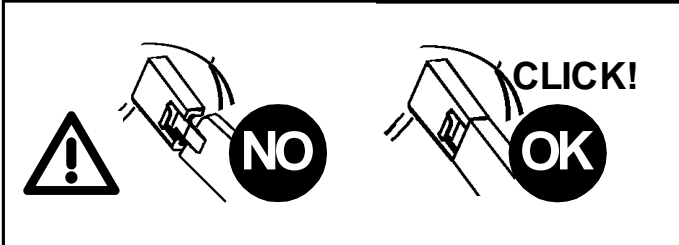
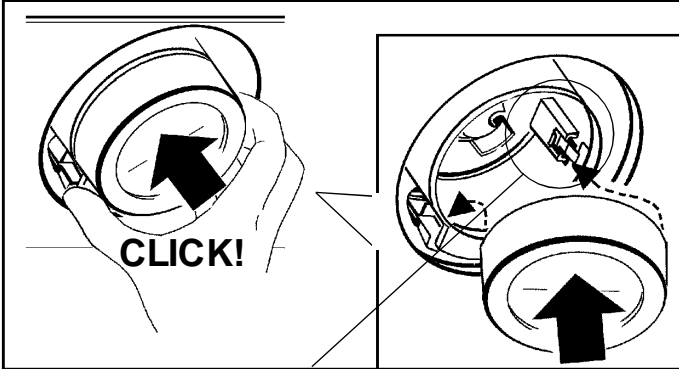
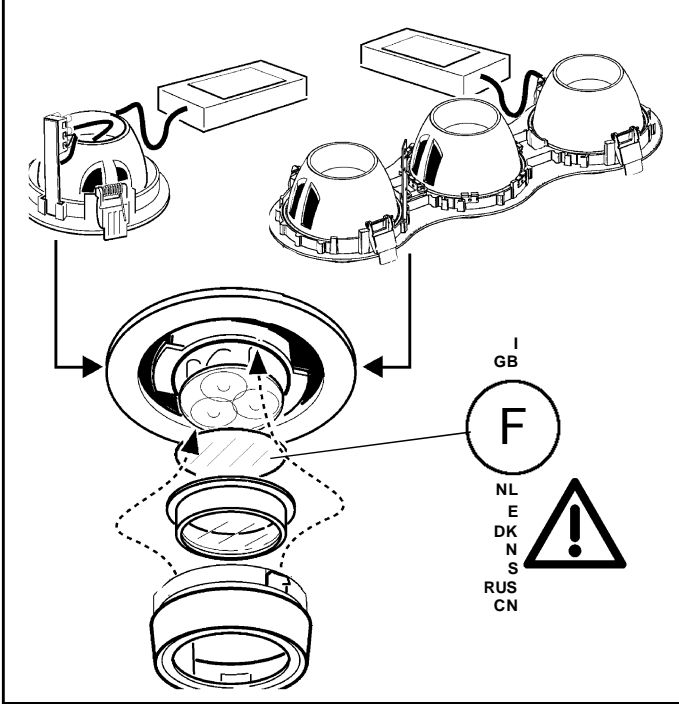
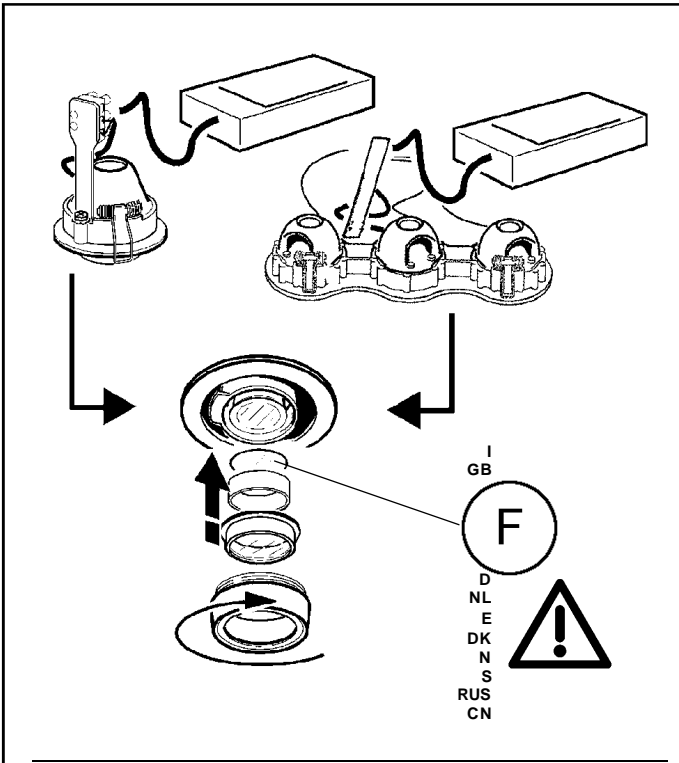

TECNICA PRO

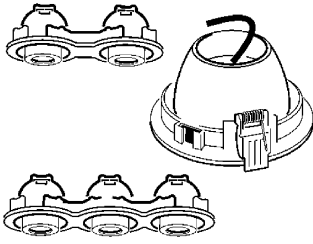

تحذير:

لا يمكن ضمان سلامة هذا الجهاز إلا إذا التزمت بهذه التعليمات. يجب حفظها في مكان آمن.

ATTENZIONE:

LA SICUREZZA DELL'APPARECCHIO E' GARANTITA SOLO CON L'USO APPROPRIATO DELLE SEGUENTI ISTRUZIONI; PERTANTO E' NECESSARIO CONSERVARLE.

WARNING:

THE SAFETY OF THIS FIXTURE IS GUARANTEED ONLY IF YOU COMPLY WITH THESE INSTRUCTIONS; REMEMBER TO CONSERVE IN A SAFE PLACE.

ATENCION:

LA SEGURIDAD DEL APARATO SE GARANTIZA SOLO CUMPLIENDO CUIDADOSAMENTE LAS SIGUIENTES INSTRUCCIONES; POR ELLO, ES NECESARIO CONSERVARLAS.

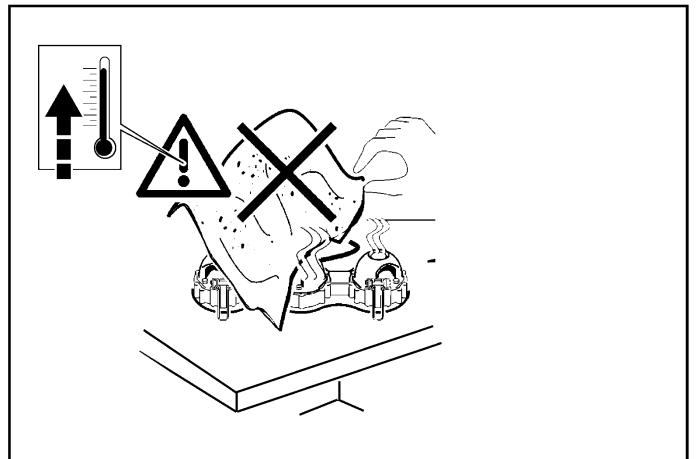
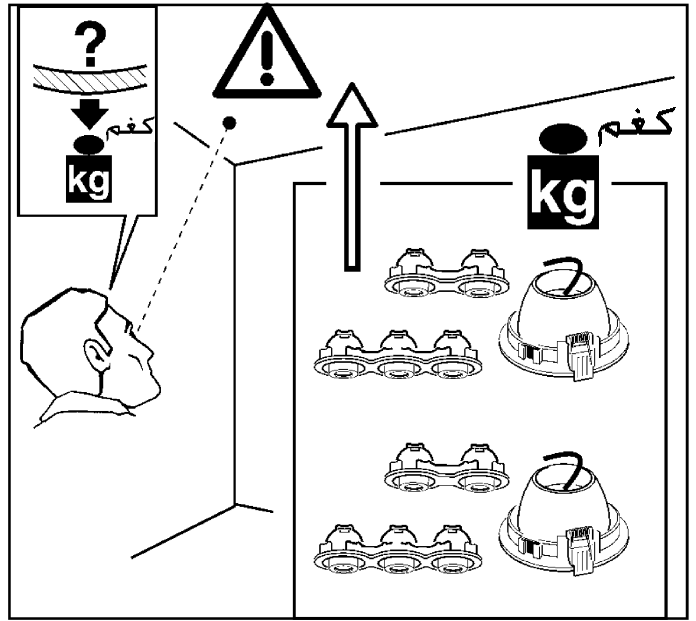
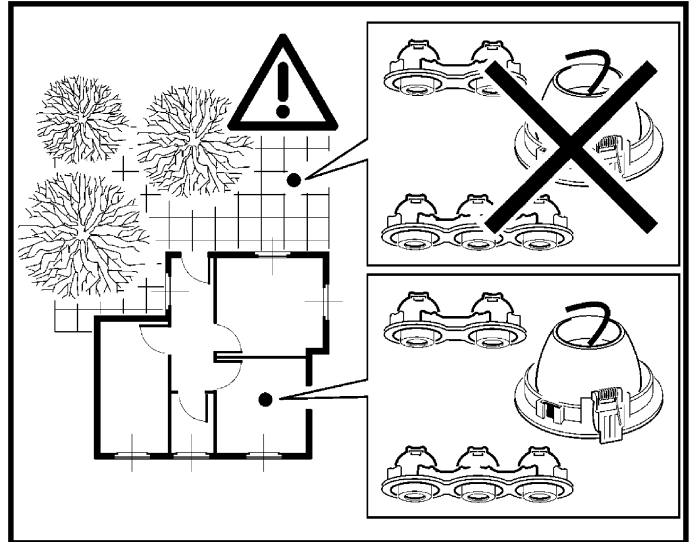
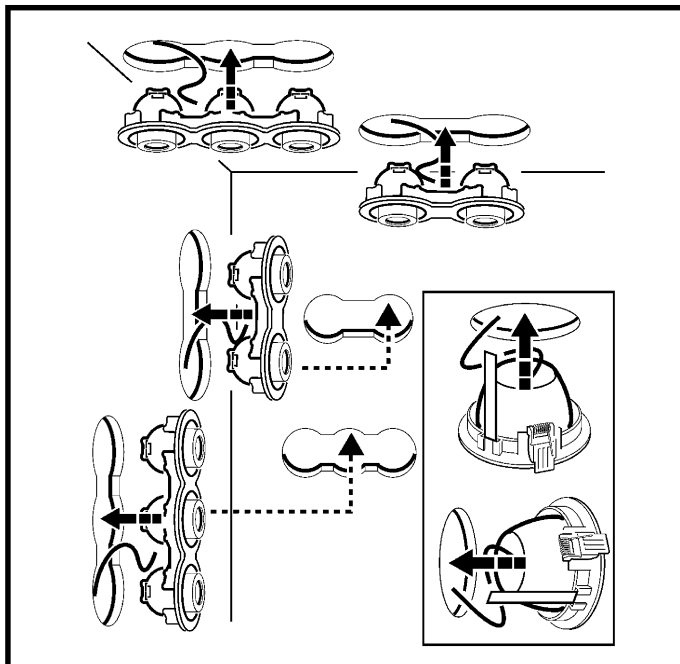
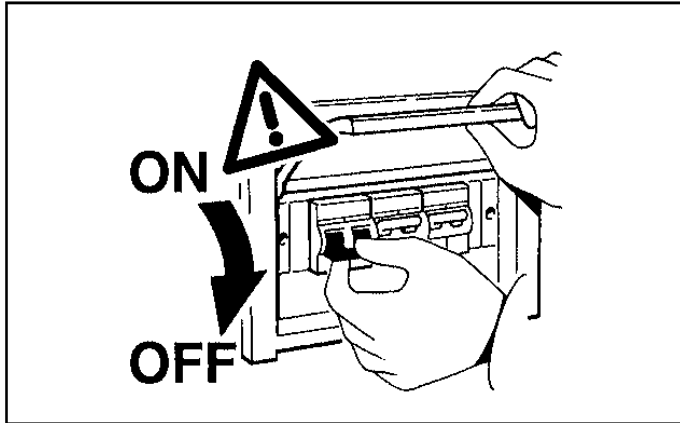

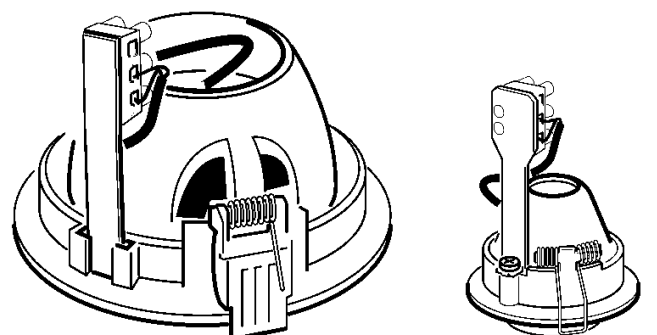
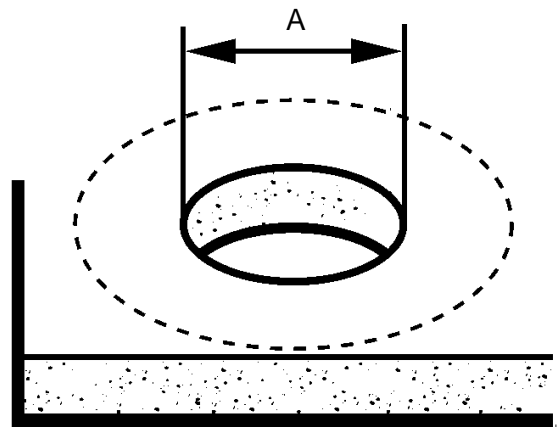
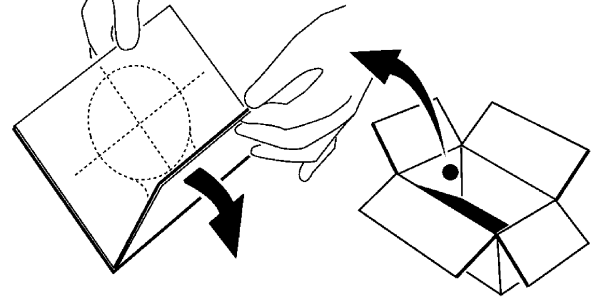
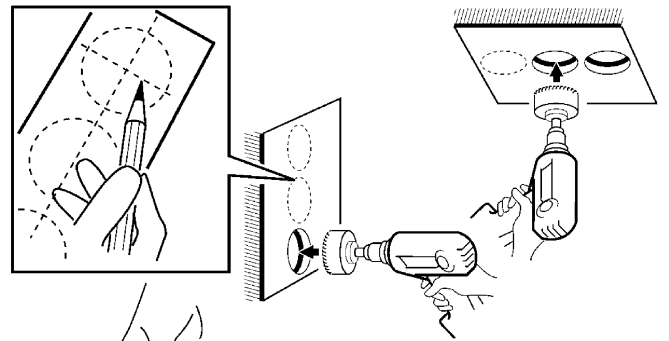
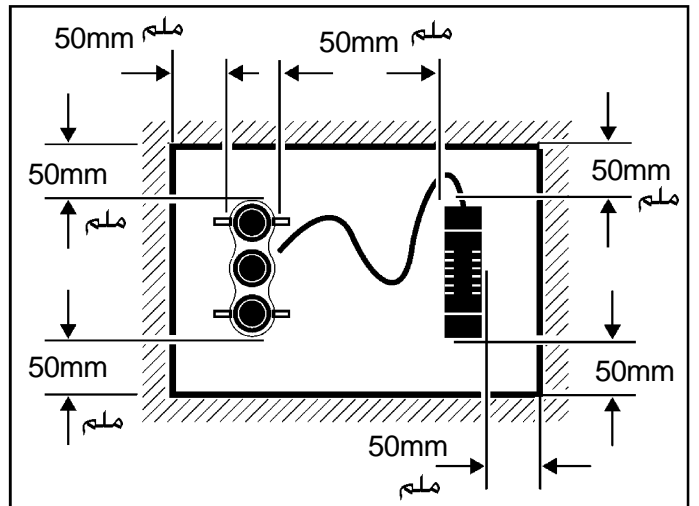
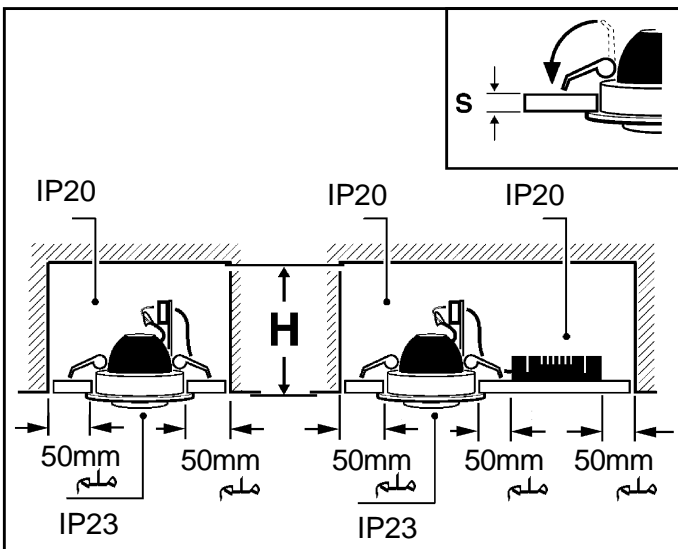
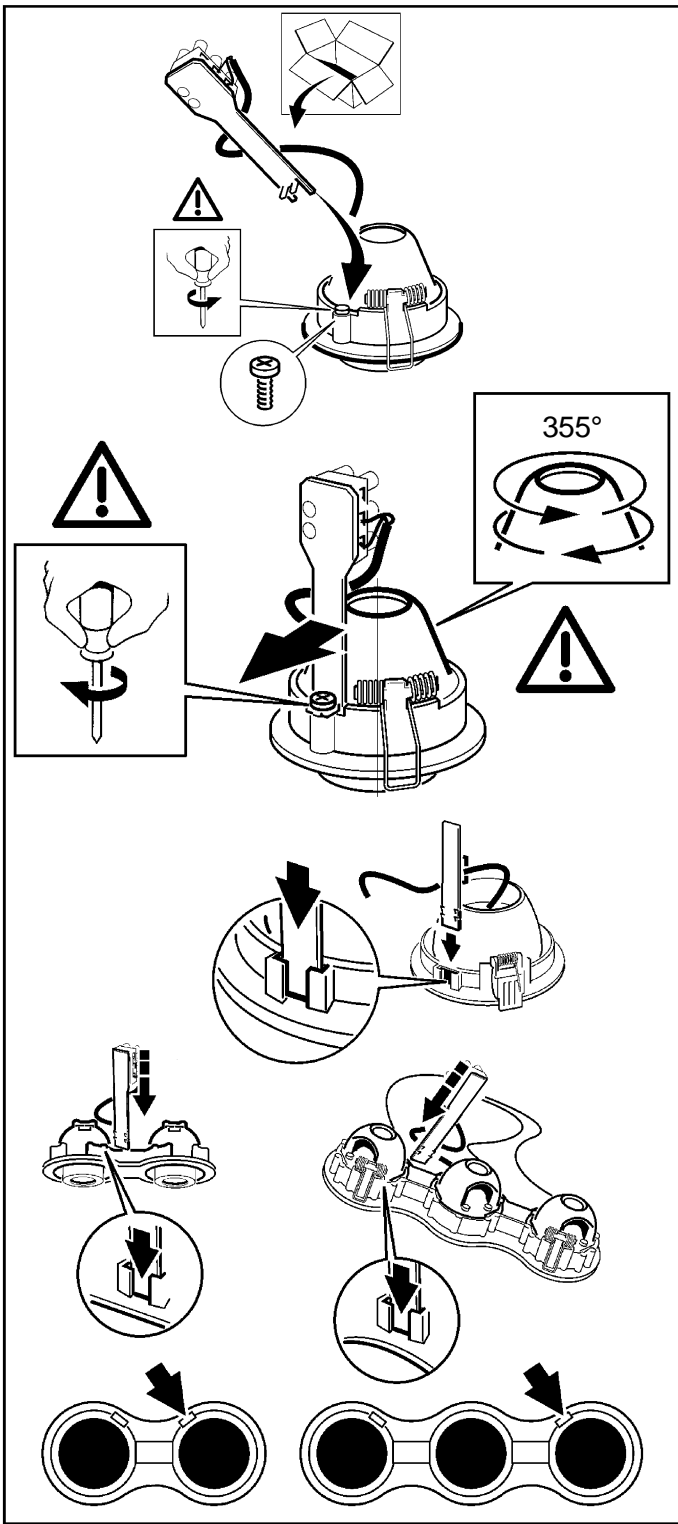

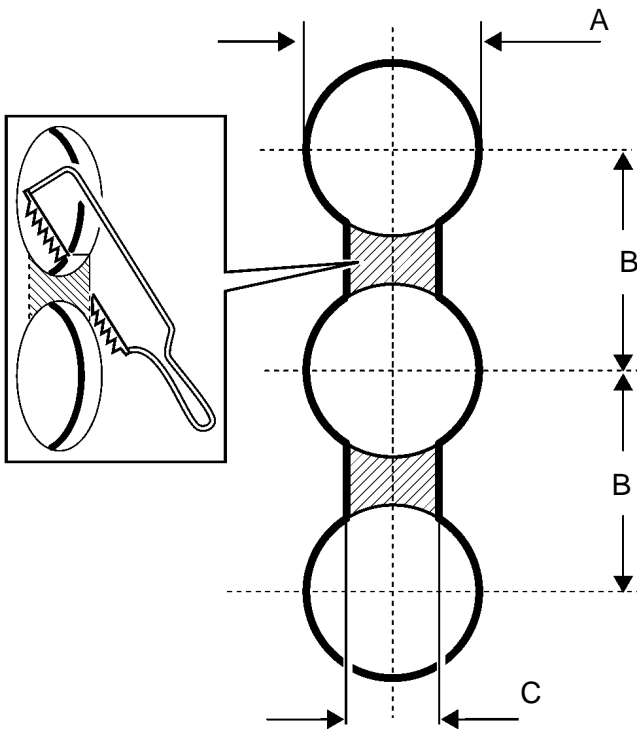
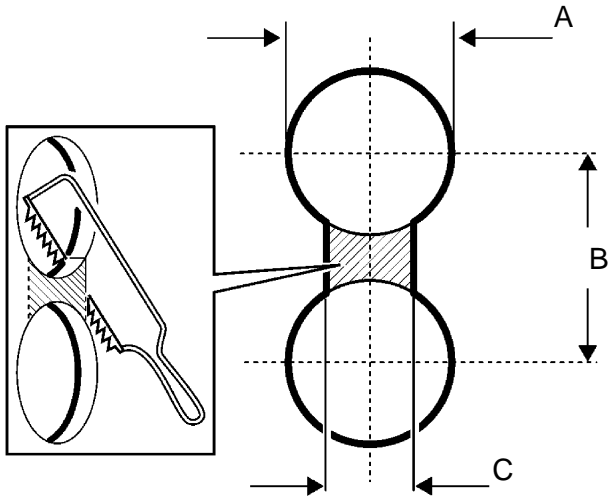

الصنف ART.	A mm مم	B mm مم	C mm مم	S mm مم	H mm مم
MS41 - MS42 MS43 - MS44 MS50 - MS51 MS52 - MS53 MS54 - MS55 MS56 - MS57	64	70,6	35	1 ÷ 20	85
MS41 - MS42 MS43 - MS44 + 6993	64	/	/	1 ÷ 20	 115
MS45 - MS46 MS47 - MS48 MS58 - MS59 MS60 - MS61 MS63 - MS64 MS65 - MS66	114	123,5	65	1 ÷ 20	85
MS45 - MS46 MS47 - MS48 + 6993	114	/	/	1 ÷ 20	85

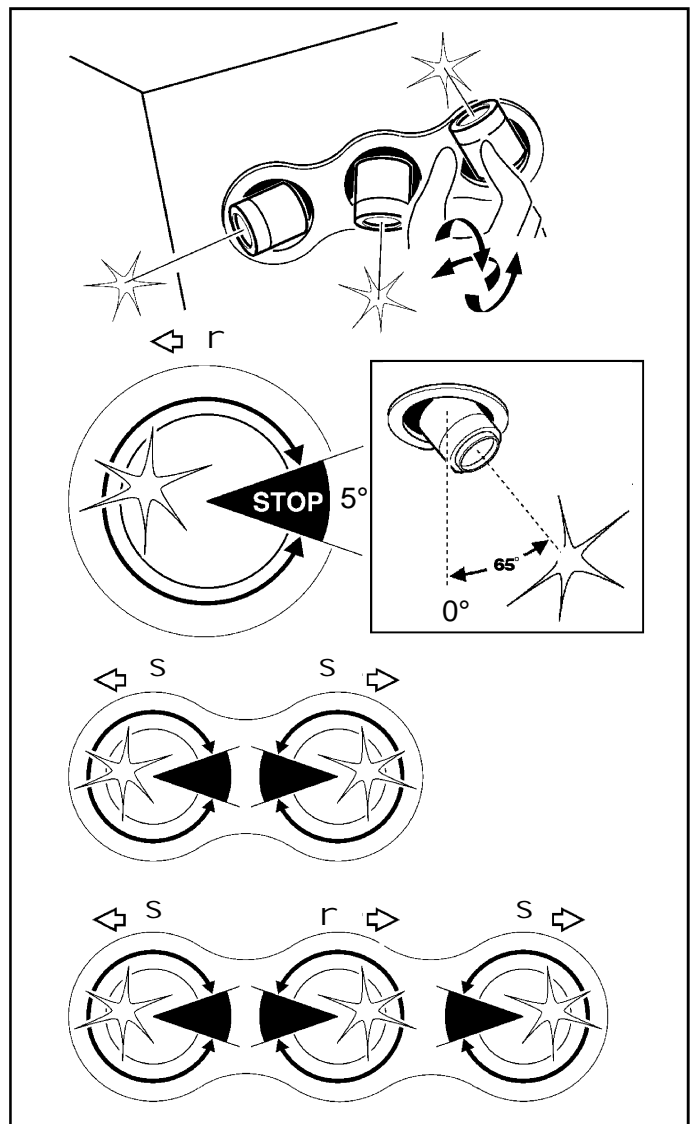
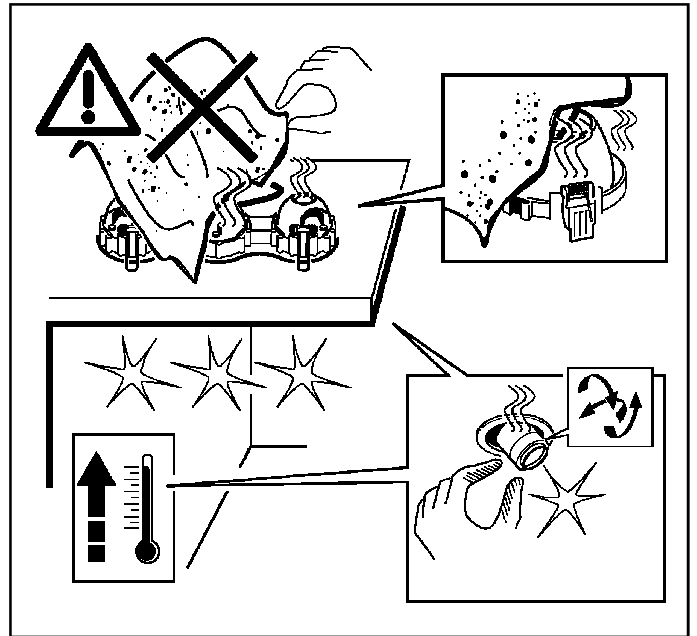

الصنف ART.	MS41-MS42-MS43 MS44-MS45-MS46 MS47-MS48	MS51-MS52-MS53 MS54-MS55-MS56 MS57	MS58-MS59- MS60-MS61 MS63-MS64 MS65-MS66
r	355°	355°	355°
S	/	355°	220°

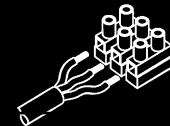
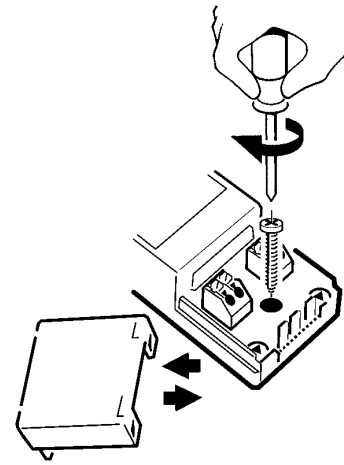
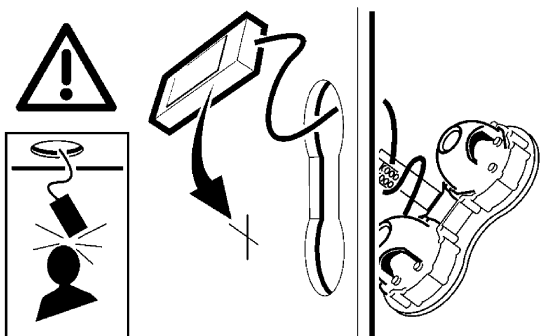
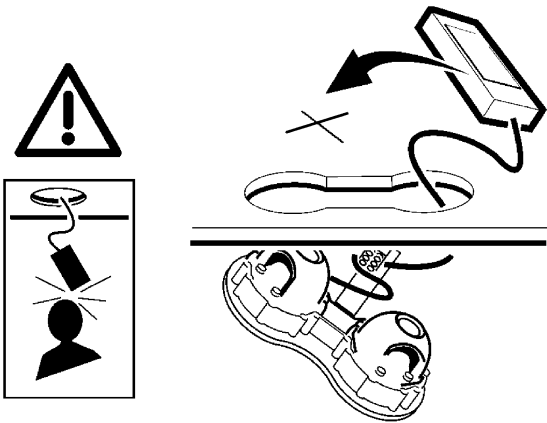
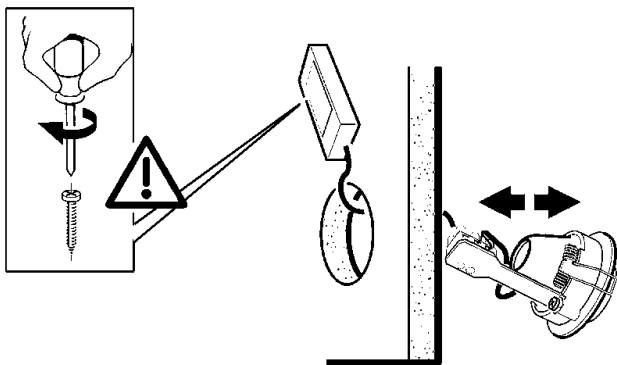
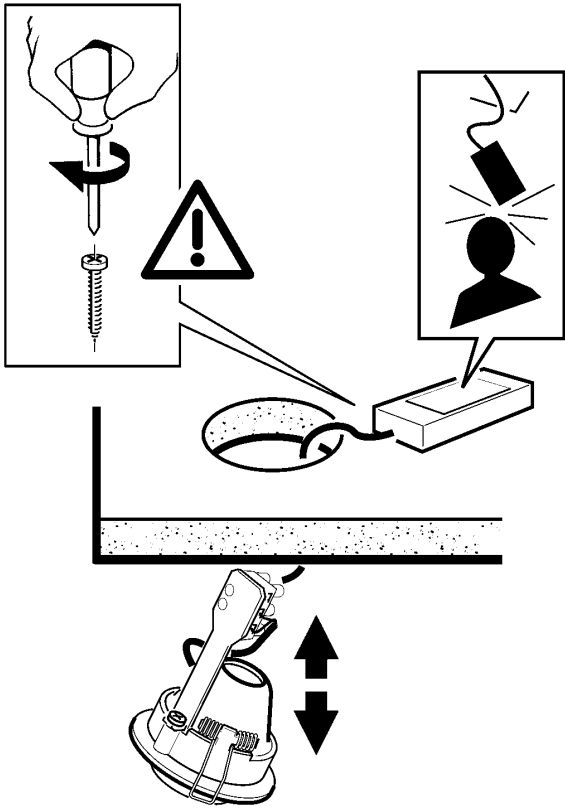

ERC

الاصنف art. 6993

كبل احمر
CAVO ROSSO
RED CABLE
CABLE ROJO

كبل اسود
CAVO NERO
BLACK CABLE
CABLE NEGRO

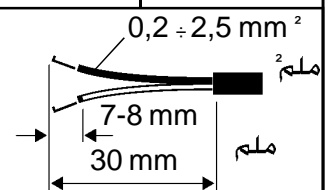
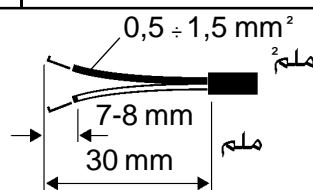
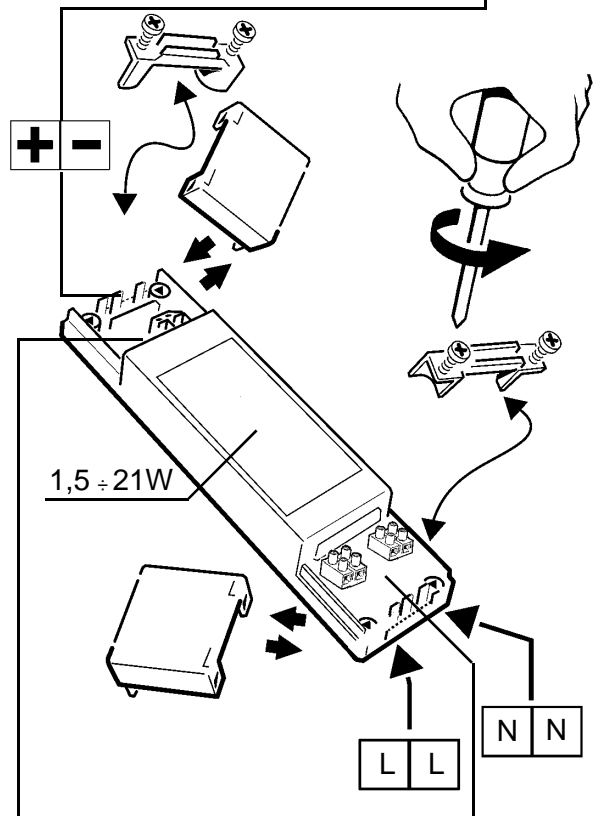
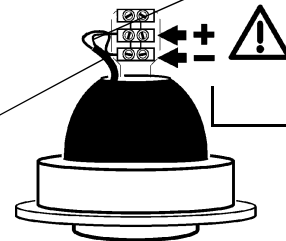

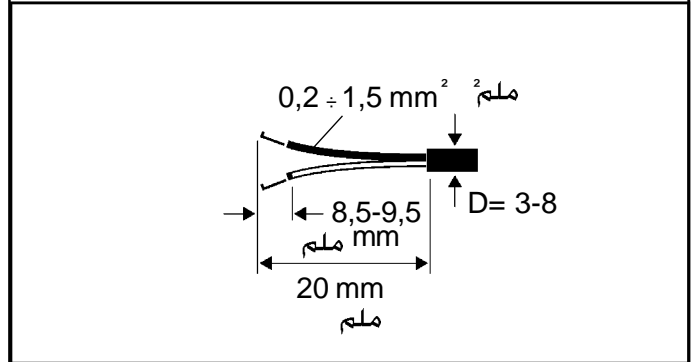
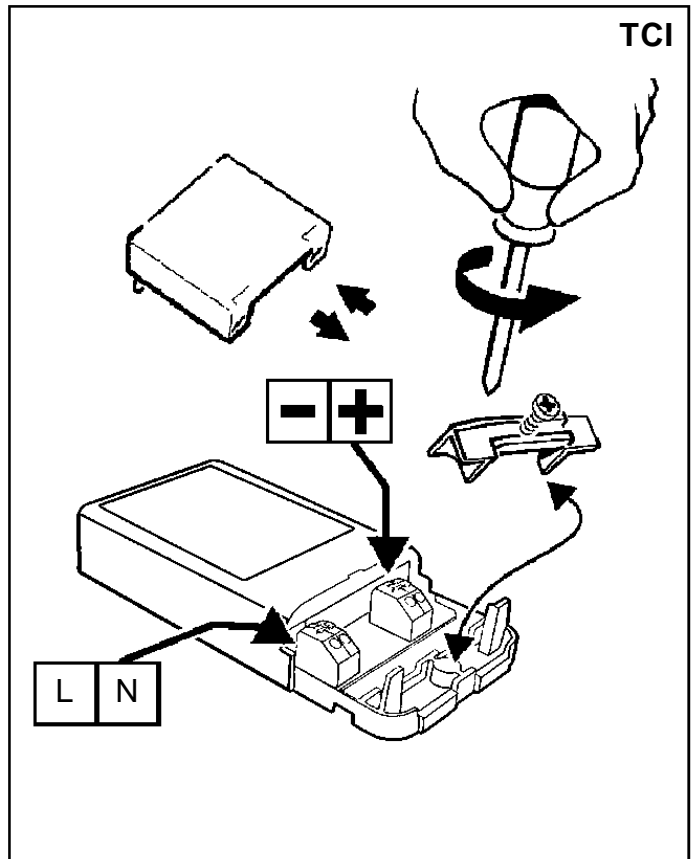
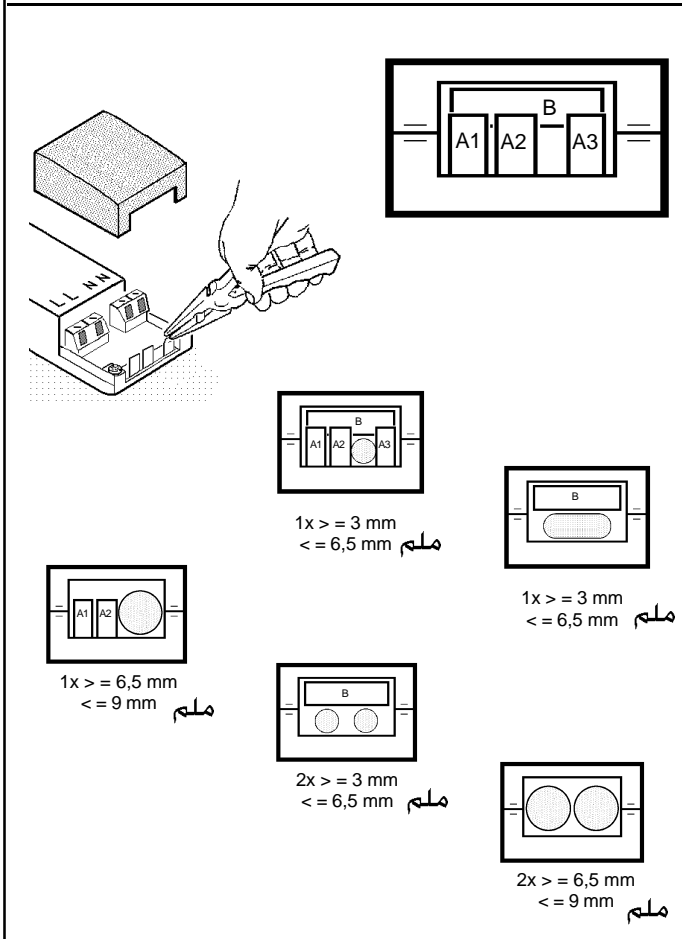
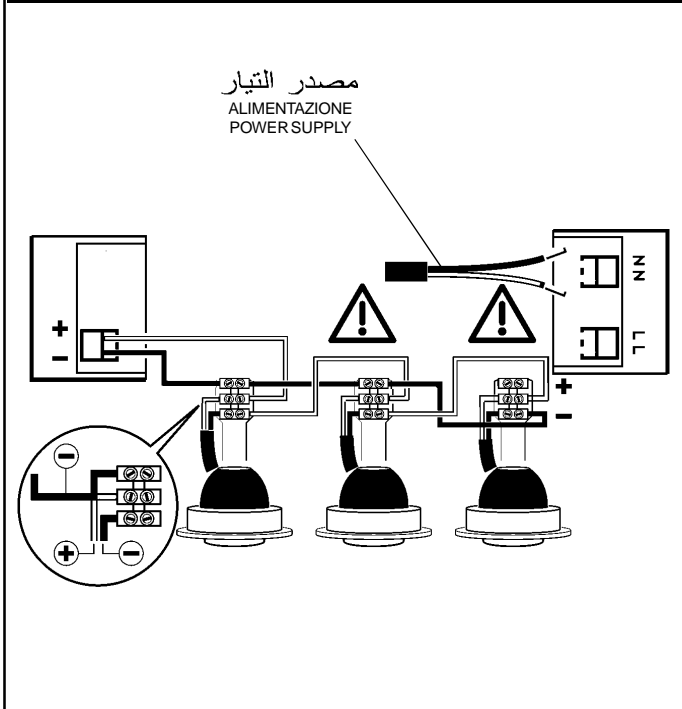
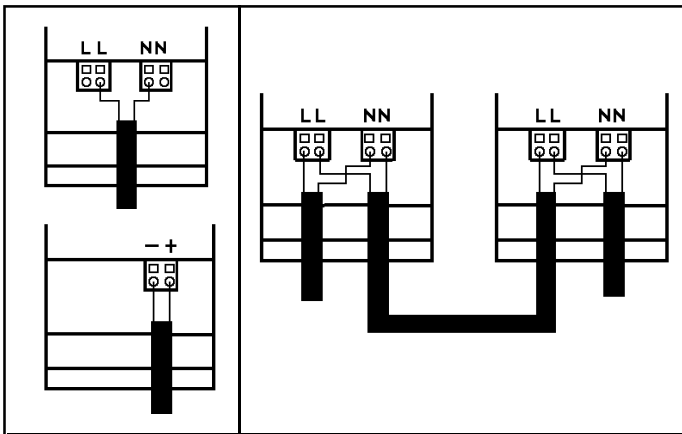

	1LED	Min - 1LED Max - 9LED
	3LED	
	2LED	
	3LED	

بتم ضمان عمل وسلامة الجهاز فقط إذا كان تروء التجار يعادل $\pm 5\%$ مقارنة مع القيمة الاسمية.
بتم ضمان التوافق فقط إذا كانت كوابح iGuzzini (سلعة رقم 6993) أو ما يشابهها من نوع SELV
متوافقة مع النظم السائدة والمحددة من قبل مجموعة الدول الأوروبية.

I Le prestazioni e la sicurezza dell'apparecchio sono garantite soltanto per oscillazioni della corrente del $\pm 5\%$ rispetto al valore nominale.

La conformità alla norma è garantita soltanto utilizzando alimentatori iGuzzini (art.: 6993) od equivalenti di tipo SELV che rispondano alle vigenti norme C.E.I.

GB The performance level and safety of the lighting fixture are only guaranteed for oscillations of $\pm 5\%$ in the current, in relation to the nominal value.

Conformity with the standard is guaranteed only if either iGuzzini ballasts (item code 6993) or equivalent SELV type ballasts which comply with current C.E.I. regulations are used.

E Las prestaciones y la seguridad del aparato están garantizada solamente con oscilaciones de la corriente del $\pm 5\%$ respecto al valor nominal.

La conformidad a la norma se garantiza solamente con el uso de alimentadores iGuzzini (art. 6993) o equivalentes de tipo SELV que cumplen las normas vigentes C.E.I.

بخصوص مشاريع الأجهزة الخاصة، تورد شركة iGuzzini بعد حصولها على الوثائق اللازمة، المعلومات المتعلقة بعدد المنتجات القابلة للتثبيت وطول الكبلات الكهربائية، بناء على وحدة التغذية الكهربائية ونوع الكبل المستخدم.

I Per progetti d'impianto personalizzati l'azienda iGuzzini fornisce, previa documentazione necessaria, i dati relativi al numero dei prodotti installabili e la lunghezza dei cavi, in funzione dell'alimentatore e del tipo di cavo utilizzato.

GB For customised installation projects iGuzzini is able to supply - accompanied by the necessary documentation - the details of the number of installable products and the length of the cables based on the ballast and type of cable used.

E Para proyectos personalizados y previo conocimiento de la documentación necesaria, iGuzzini puede suministrar datos sobre el número de productos a instalar y la longitud de los cables en

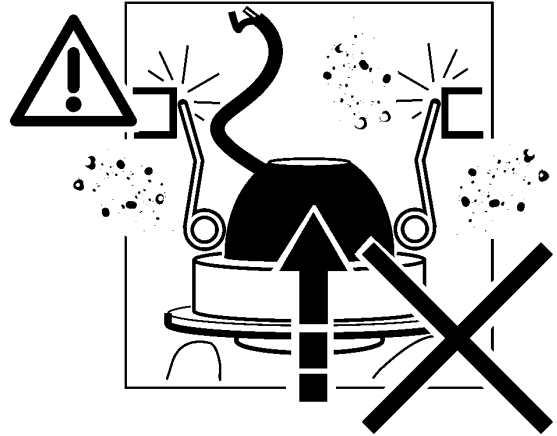
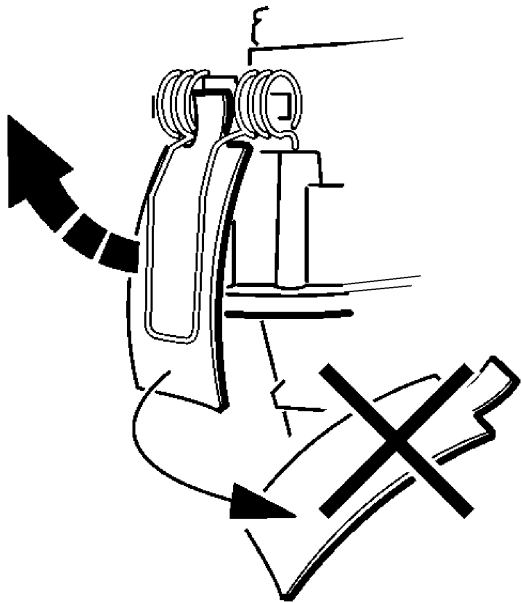
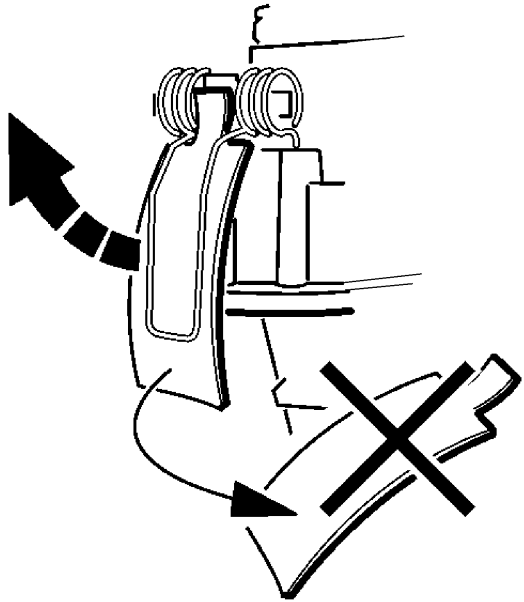
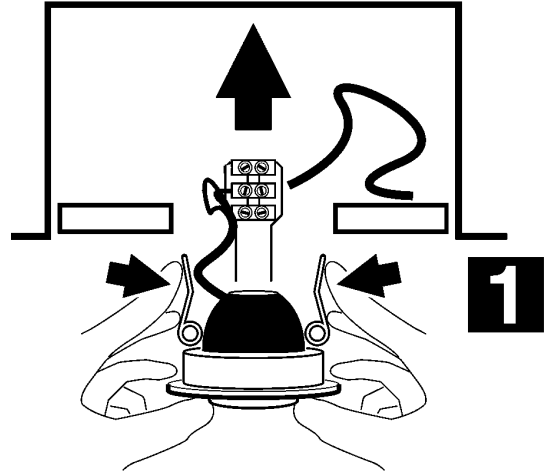

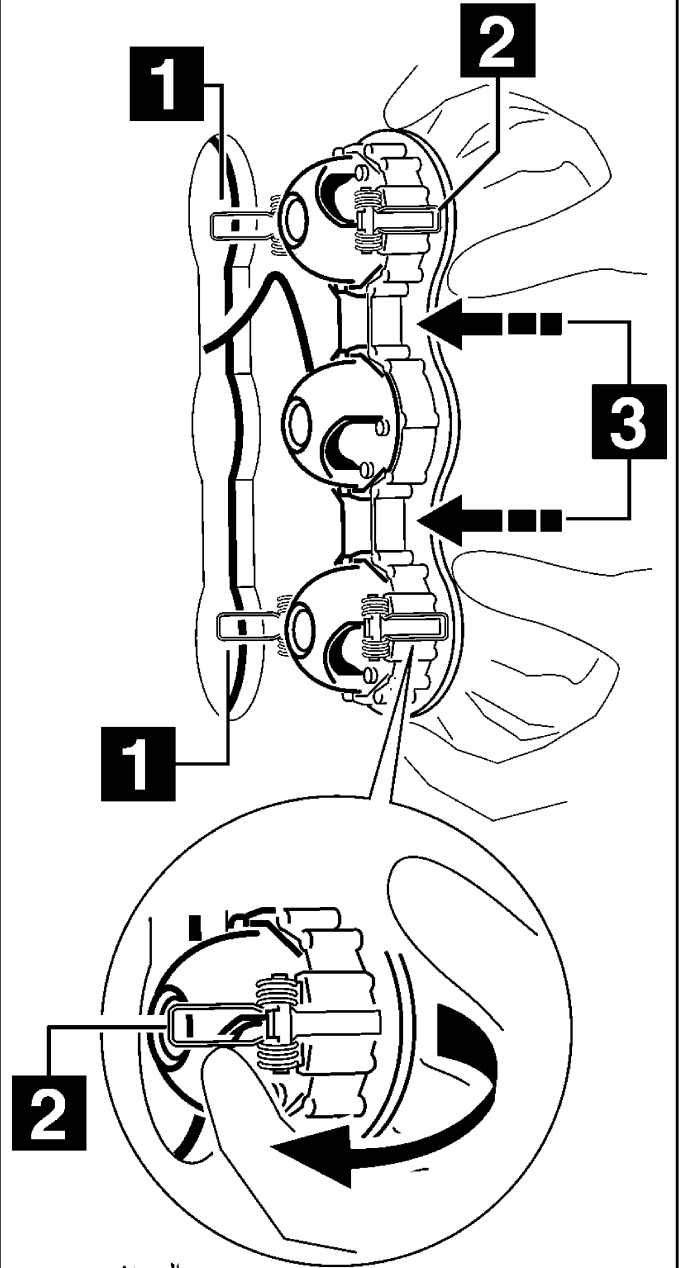
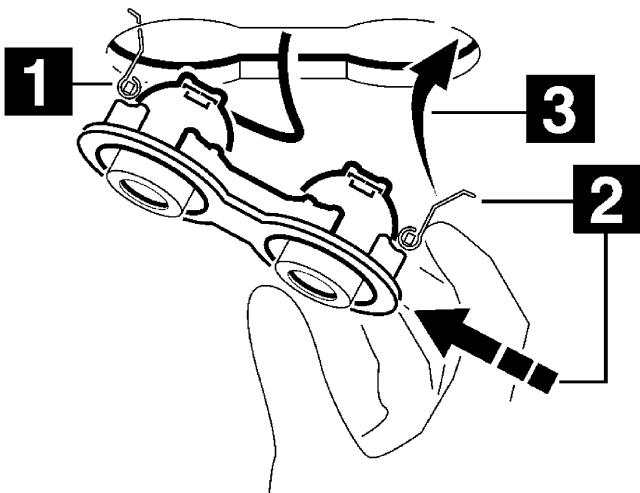
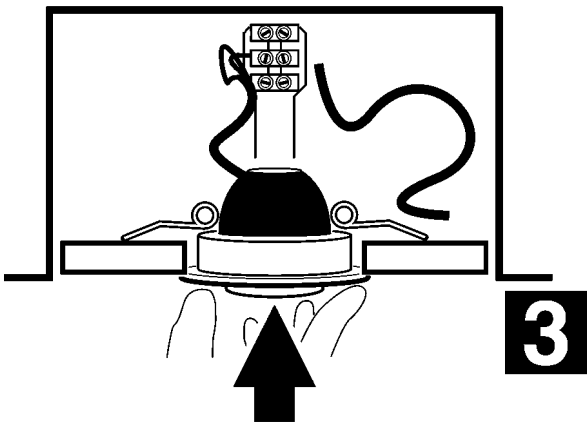
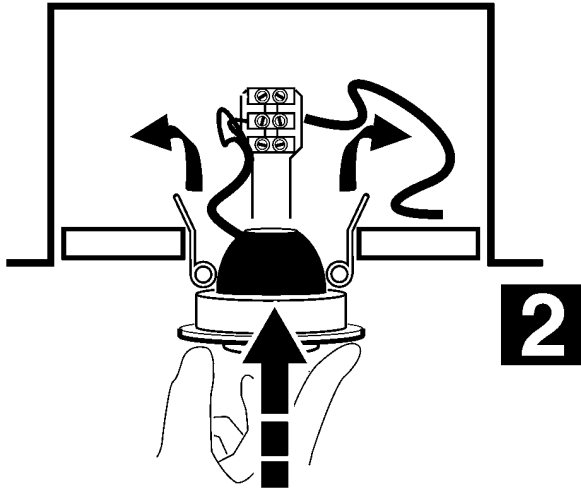

الصنف

art. 6910 - 6936 - MW57 - MW58

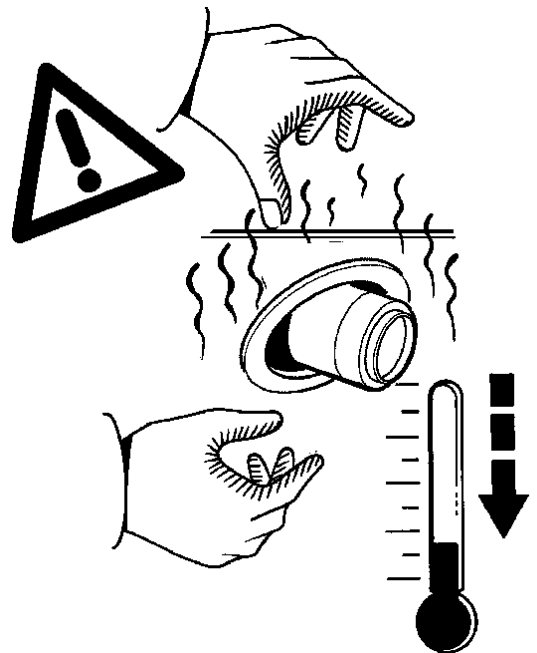

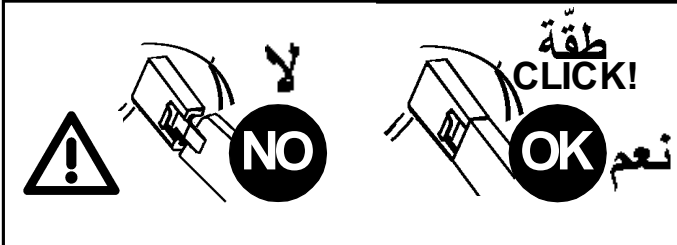
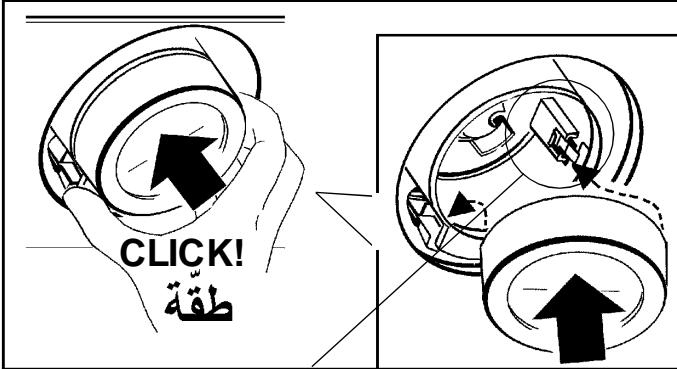
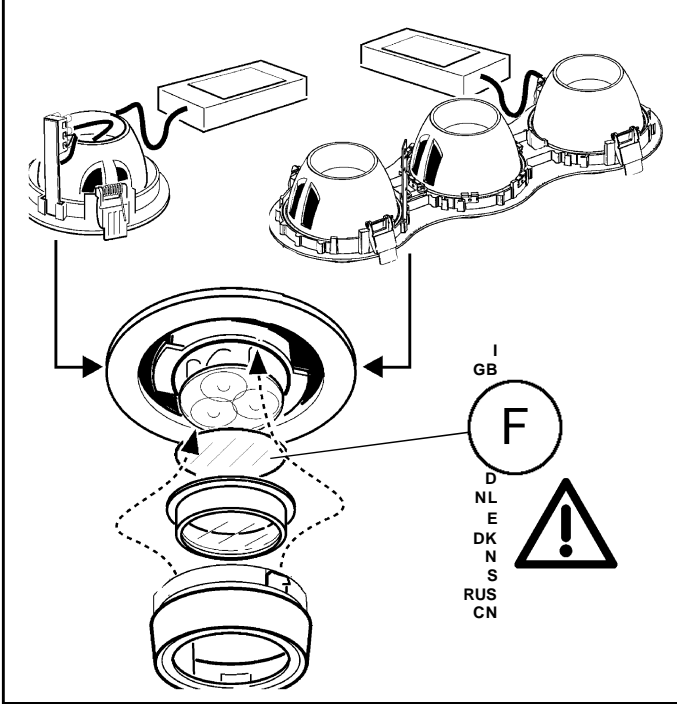
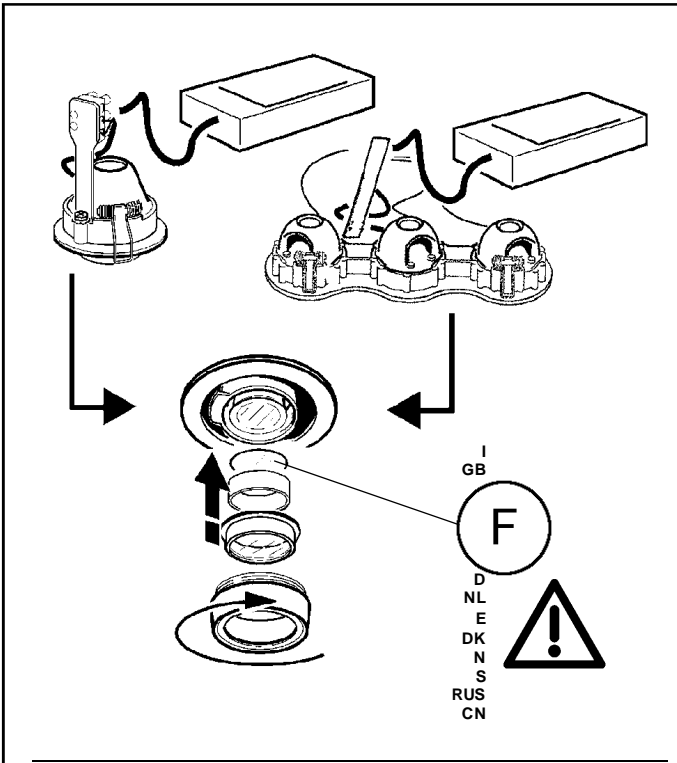

2.518.543.00 IS08261/00 iGuzini	fattore di potenza power factor facteur de puissance Leistungsfaktor vermogensfactor factor de potencia effektfaktor effektfaktor effektfaktor фактор мощности 功率因数	corrente assorbita absorbed current courant absorbé de puissance Stromaufnahme stroomopname corriente absorbida absorberet strøm absorberet strøm tillford strøm поглощаемая мощность 电源电流 (A)	Vf
ART.			
MK88 - MK89 - MK90 MK91 - MK93 - MR99 MS00 - MS01 - MS02 MS03 - MS04 - MS05 MS06 - MS07 - MS08 MS09 - MS10 - MS11 MS12 - MS13 - MS14 MS15 - MS16	0,9	0,09	/
MS17 - MS18 - MS19 MS20 - MS21 - MS22 MS23 - MS24 - MS25 MS26 - MS27 - MS28 MS29 - MS30 - MS31 MS32 - MS33 - MS34 MS35 - MS36 - MS37 MS38 - MS39 - MS40	0,9	0,155	/
MS41 - MS42 - MS43 - MS44	/	0,6	3,5
MS45 - MS46 - MS47 - MS48	/	0,6	10,5
MS49	/	0,5 R - 0,6 GB	
MS50 - MS51 - MS52 - MS53	/	0,6	7,5
MS54 - MS55 - MS56 - MS57	/	0,6	11,5
MS58 - MS59 - MS60 - MS61	0,9	0,05	/
MS62		0,2	
MS63 - MS64 - MS65 - MS66	0,9	0,09	
MS67		0,2	
MS71 - MS72	0,6	0,11	
MS73 MS74	0,95	0,2	
MS77 - MS78 MS79 - MS80	0,9	0,2	
MS82		0,36	
MS83 - MS84	0,9	(35W)0,2 - (70W)0,36 (35W)0,2 (50W)0,24 (70W)0,36 (100W)0,47	
MS85 - MS86	0,9	0,7	
MS87 - MS88	0,9	(50W)0,24 - (100W)0,47	
MS92 - MS93	0,9	0,11	
MS94 - MS95 - MS98 - MS99 MT04	0,9	0,2	
MT00 - MT01 - MT06	0,9	0,36	
MT02 - MT03 - MT05	0,9	0,24	
MT07	0,9	(35W)0,2 (50W)0,24 (70W)0,36 (100W)0,47	
MT08	0,9	0,7	
MT09	0,95	(50W)0,24 - (100W)0,47	

2.518.543.00 IS08261/00 iGuzini	fattore di potenza power factor facteur de puissance Leistungsfaktor vermogensfactor factor de potencia effektfaktor effektfaktor effektfaktor фактор мощности 功率因数	corrente assorbita absorbed current courant absorbé de puissance Stromaufnahme stroomopname corriente absorbida absorberet strøm absorberet strøm tillford strøm поглощаемая мощность 电源电流 (A)	Vf
ART.			
MK88 - MK89 - MK90 MK91 - MK93 - MR99 MS00 - MS01 - MS02 MS03 - MS04 - MS05 MS06 - MS07 - MS08 MS09 - MS10 - MS11 MS12 - MS13 - MS14 MS15 - MS16	0,9	0,09	/
MS17 - MS18 - MS19 MS20 - MS21 - MS22 MS23 - MS24 - MS25 MS26 - MS27 - MS28 MS29 - MS30 - MS31 MS32 - MS33 - MS34 MS35 - MS36 - MS37 MS38 - MS39 - MS40	0,9	0,155	/
MS41 - MS42 - MS43 - MS44	/	0,6	3,5
MS45 - MS46 - MS47 - MS48	/	0,6	10,5
MS49	/	0,5 R - 0,6 GB	
MS50 - MS51 - MS52 - MS53	/	0,6	7,5
MS54 - MS55 - MS56 - MS57	/	0,6	11,5
MS58 - MS59 - MS60 - MS61	0,9	0,05	/
MS62		0,2	
MS63 - MS64 - MS65 - MS66	0,9	0,09	
MS67		0,2	
MS71 - MS72	0,6	0,11	
MS73 MS74	0,95	0,2	
MS77 - MS78 MS79 - MS80	0,9	0,2	
MS82		0,36	
MS83 - MS84	0,9	(35W)0,2 - (70W)0,36 (35W)0,2 (50W)0,24 (70W)0,36 (100W)0,47	
MS85 - MS86	0,9	0,7	
MS87 - MS88	0,9	(50W)0,24 - (100W)0,47	
MS92 - MS93	0,9	0,11	
MS94 - MS95 - MS98 - MS99 MT04	0,9	0,2	
MT00 - MT01 - MT06	0,9	0,36	
MT02 - MT03 - MT05	0,9	0,24	
MT07	0,9	(35W)0,2 (50W)0,24 (70W)0,36 (100W)0,47	
MT08	0,9	0,7	
MT09	0,95	(50W)0,24 - (100W)0,47	

2.510.090.00
IS10185/00

iGuzzini

- I** N.B.: Per la sostituzione del LED contattare l'azienda iGuzzini.
GB N.B.: For information on LED replacement please contact iGuzzini.
F N.B.: Pour procéder au remplacement de la LED, adressez-vous à la société iGuzzini...
D N.B.: Bezüglich des Austausches der LED kontaktieren Sie bitte die Firma iGuzzini.
NL N.B.: Voor het vervangen van de LED neemt u contact op met het bedrijf iGuzzini.
E NOTA: Para sustituir el LED llame a la empresa iGuzzini.
DK N.B.: For udskiftning af lysdioden, skal man kontakte iGuzzini.
N N.B.: For informasjon om skifte av LED, vennligst ta kontakt med iGuzzini.
S OBS! För byte av lysdioden, kontakta företaget iGuzzini.
RUS ПРИМЕЧАНИЕ: Для замены СИДов обращайтесь в компанию iGuzzini.
CN 注意：如需LED更换的信息，请联系iGuzzini。



- I** Non fissare la sorgente luminosa durante il suo funzionamento.
GB Do not stare at the operating lighting source
F Ne pas fixer la source lumineuse lorsqu'elle est allumée.
D Die Lichtquelle nicht über längere Zeit mit dem Blick fixieren.
NL Bevestig de lichtbron niet terwijl deze in werking is.
E No mire directamente a la fuente luminosa durante el funcionamiento.
DK Fastgør ikke lyskilden under dens drift.
N Se ikke direkte på lyskilden når den er i funksjon.
S Fäst inte ljuskällan medan den är i funktion
RUS Не смотрите на источник света во время его функционирования
CN 请勿注视亮着的光源。

- I** L'apparecchio dovrebbe essere posizionato in modo che non sia prevista un'osservazione prolungata dell'apparecchio ad una distanza inferiore di 5 m.
GB The luminaire should be positioned so that prolonged staring into the luminaire at a distance closer than 5 m is not expected.
FR Il faudrait placer l'appareil de manière à ce qu'aucune observation prolongée de l'appareil ne soit possible à moins de 5 m de distance
D Das Gerät so positionieren, dass der Anwender nicht über längere Zeit aus weniger als 5 m Abstand angestrahlt wird.
NL Het apparaat moet zodanig geplaatst worden dat er geen langdurige observatie van het apparaat te voorzien is op een afstand van minder dan 5 m
E El aparato debe emplazarse de manera tal que la observación prolongada se realice a una distancia de al menos 5 m.
DK Apparatet skal placeres på et sted, så der ikke kræves en forlængerledning, der er længere end 5 meter
N Apparatet bør plasseres slik at man ikke behøver å se på det i lengre tid på mindre avstand enn 5 m
S Apparatet ska placeras så att det inte är möjligt att titta in i den under en längre tid på ett avstånd kortare än 5 m
RUS Прибор следует установить так, чтобы не смотреть на него продолжительное время, если расстояние не достигает 5 м.
CN 灯具应按照该种方式安置，以确保其在 5 米以内的距离中可以长时间地不被发现

2.510.090.00
IS10185/00

iGuzzini

- I** N.B.: Per la sostituzione del LED contattare l'azienda iGuzzini.
GB N.B.: For information on LED replacement please contact iGuzzini.
F N.B.: Pour procéder au remplacement de la LED, adressez-vous à la société iGuzzini...
D N.B.: Bezüglich des Austausches der LED kontaktieren Sie bitte die Firma iGuzzini.
NL N.B.: Voor het vervangen van de LED neemt u contact op met het bedrijf iGuzzini.
E NOTA: Para sustituir el LED llame a la empresa iGuzzini.
DK N.B.: For udskiftning af lysdioden, skal man kontakte iGuzzini.
N N.B.: For informasjon om skifte av LED, vennligst ta kontakt med iGuzzini.
S OBS! För byte av lysdioden, kontakta företaget iGuzzini.
RUS ПРИМЕЧАНИЕ: Для замены СИДов обращайтесь в компанию iGuzzini.
CN 注意：如需LED更换的信息，请联系iGuzzini。



- I** Non fissare la sorgente luminosa durante il suo funzionamento.
GB Do not stare at the operating lighting source
F Ne pas fixer la source lumineuse lorsqu'elle est allumée.
D Die Lichtquelle nicht über längere Zeit mit dem Blick fixieren.
NL Bevestig de lichtbron niet terwijl deze in werking is.
E No mire directamente a la fuente luminosa durante el funcionamiento.
DK Fastgør ikke lyskilden under dens drift.
N Se ikke direkte på lyskilden når den er i funksjon.
S Fäst inte ljuskällan medan den är i funktion
RUS Не смотрите на источник света во время его функционирования
CN 请勿注视亮着的光源。

- I** L'apparecchio dovrebbe essere posizionato in modo che non sia prevista un'osservazione prolungata dell'apparecchio ad una distanza inferiore di 5 m.
GB The luminaire should be positioned so that prolonged staring into the luminaire at a distance closer than 5 m is not expected.
FR Il faudrait placer l'appareil de manière à ce qu'aucune observation prolongée de l'appareil ne soit possible à moins de 5 m de distance
D Das Gerät so positionieren, dass der Anwender nicht über längere Zeit aus weniger als 5 m Abstand angestrahlt wird.
NL Het apparaat moet zodanig geplaatst worden dat er geen langdurige observatie van het apparaat te voorzien is op een afstand van minder dan 5 m
E El aparato debe emplazarse de manera tal que la observación prolongada se realice a una distancia de al menos 5 m.
DK Apparatet skal placeres på et sted, så der ikke kræves en forlængerledning, der er længere end 5 meter
N Apparatet bør plasseres slik at man ikke behøver å se på det i lengre tid på mindre avstand enn 5 m
S Apparatet ska placeras så att det inte är möjligt att titta in i den under en längre tid på ett avstånd kortare än 5 m
RUS Прибор следует установить так, чтобы не смотреть на него продолжительное время, если расстояние не достигает 5 м.
CN 灯具应按照该种方式安置，以确保其在 5 米以内的距离中可以长时间地不被发现

2.510.090.00
IS10185/00

iGuzzini

- I** N.B.: Per la sostituzione del LED contattare l'azienda iGuzzini.
GB N.B.: For information on LED replacement please contact iGuzzini.
F N.B.: Pour procéder au remplacement de la LED, adressez-vous à la société iGuzzini...
D N.B.: Bezüglich des Austausches der LED kontaktieren Sie bitte die Firma iGuzzini.
NL N.B.: Voor het vervangen van de LED neemt u contact op met het bedrijf iGuzzini.
E NOTA: Para sustituir el LED llame a la empresa iGuzzini.
DK N.B.: For udskiftning af lysdioden, skal man kontakte iGuzzini.
N N.B.: For informasjon om skifte av LED, vennligst ta kontakt med iGuzzini.
S OBS! För byte av lysdioden, kontakta företaget iGuzzini.
RUS ПРИМЕЧАНИЕ: Для замены СИДов обращайтесь в компанию iGuzzini.
CN 注意：如需LED更换的信息，请联系iGuzzini。



- I** Non fissare la sorgente luminosa durante il suo funzionamento.
GB Do not stare at the operating lighting source
F Ne pas fixer la source lumineuse lorsqu'elle est allumée.
D Die Lichtquelle nicht über längere Zeit mit dem Blick fixieren.
NL Bevestig de lichtbron niet terwijl deze in werking is.
E No mire directamente a la fuente luminosa durante el funcionamiento.
DK Fastgør ikke lyskilden under dens drift.
N Se ikke direkte på lyskilden når den er i funksjon.
S Fäst inte ljuskällan medan den är i funktion
RUS Не смотрите на источник света во время его функционирования
CN 请勿注视亮着的光源。

- I** L'apparecchio dovrebbe essere posizionato in modo che non sia prevista un'osservazione prolungata dell'apparecchio ad una distanza inferiore di 5 m.
GB The luminaire should be positioned so that prolonged staring into the luminaire at a distance closer than 5 m is not expected.
FR Il faudrait placer l'appareil de manière à ce qu'aucune observation prolongée de l'appareil ne soit possible à moins de 5 m de distance
D Das Gerät so positionieren, dass der Anwender nicht über längere Zeit aus weniger als 5 m Abstand angestrahlt wird.
NL Het apparaat moet zodanig geplaatst worden dat er geen langdurige observatie van het apparaat te voorzien is op een afstand van minder dan 5 m
E El aparato debe emplazarse de manera tal que la observación prolongada se realice a una distancia de al menos 5 m.
DK Apparatet skal placeres på et sted, så der ikke kræves en forlængerledning, der er længere end 5 meter
N Apparatet bør plasseres slik at man ikke behøver å se på det i lengre tid på mindre avstand enn 5 m
S Apparatet ska placeras så att det inte är möjligt att titta in i den under en längre tid på ett avstånd kortare än 5 m
RUS Прибор следует установить так, чтобы не смотреть на него продолжительное время, если расстояние не достигает 5 м.
CN 灯具应按照该种方式安置，以确保其在 5 米以内的距离中可以长时间地不被发现

2.509.453.00
IS10302/00

iGuzzini

ملاحظة: لاستبدال الضوء، اتصل بشركة iGuzzini

I N.B.: Per la sostituzione del LED contattare l'azienda iGuzzini.

GB N.B.: For information on LED replacement please contact iGuzzini.

E NOTA: Para sustituir el LED llame a la empresa iGuzzini.



ع يجب عدم محاولة تثبيت المصدر الضوئي في أثناء تشغيله

I Non fissare la sorgente luminosa durante il suo funzionamento.

GB Do not stare at the operating lighting source

E No mire directamente a la fuente luminosa durante el funcionamiento.

ع فاسم نم، ءل يوط ءرتفل زاهل اءبقارم ءقوت مدع رابت عال
ني عب ذخوي ثي حب، زاهل اءضوب جي رتم 5 نم لقا

I L'apparecchio dovrebbe essere posizionato in modo che non sia prevista un'osservazione prolungata dell'apparecchio ad una distanza inferiore di 5 m.

GB The luminaire should be positioned so that prolonged staring into the luminaire at a distance closer than 5 m is not expected.

E El aparato debe emplazarse de manera tal que la observación prolongada se realice a una distancia de al menos 5 m.

2.509.453.00
IS10302/00

iGuzzini

ملاحظة: لاستبدال الضوء، اتصل بشركة iGuzzini

I N.B.: Per la sostituzione del LED contattare l'azienda iGuzzini.

GB N.B.: For information on LED replacement please contact iGuzzini.

E NOTA: Para sustituir el LED llame a la empresa iGuzzini.



ع يجب عدم محاولة تثبيت المصدر الضوئي في أثناء تشغيله

I Non fissare la sorgente luminosa durante il suo funzionamento.

GB Do not stare at the operating lighting source

E No mire directamente a la fuente luminosa durante el funcionamiento.

ع فاسم نم، ءل يوط ءرتفل زاهل اءبقارم ءقوت مدع رابت عال
ني عب ذخوي ثي حب، زاهل اءضوب جي رتم 5 نم لقا

I L'apparecchio dovrebbe essere posizionato in modo che non sia prevista un'osservazione prolungata dell'apparecchio ad una distanza inferiore di 5 m.

GB The luminaire should be positioned so that prolonged staring into the luminaire at a distance closer than 5 m is not expected.

E El aparato debe emplazarse de manera tal que la observación prolongada se realice a una distancia de al menos 5 m.

2.509.453.00
IS10302/00

iGuzzini

ملاحظة: لاستبدال الضوء، اتصل بشركة iGuzzini

I N.B.: Per la sostituzione del LED contattare l'azienda iGuzzini.

GB N.B.: For information on LED replacement please contact iGuzzini.

E NOTA: Para sustituir el LED llame a la empresa iGuzzini.



ع يجب عدم محاولة تثبيت المصدر الضوئي في أثناء تشغيله

I Non fissare la sorgente luminosa durante il suo funzionamento.

GB Do not stare at the operating lighting source

E No mire directamente a la fuente luminosa durante el funcionamiento.

ع فاسم نم، ءل يوط ءرتفل زاهل اءبقارم ءقوت مدع رابت عال
ني عب ذخوي ثي حب، زاهل اءضوب جي رتم 5 نم لقا

I L'apparecchio dovrebbe essere posizionato in modo che non sia prevista un'osservazione prolungata dell'apparecchio ad una distanza inferiore di 5 m.

GB The luminaire should be positioned so that prolonged staring into the luminaire at a distance closer than 5 m is not expected.

E El aparato debe emplazarse de manera tal que la observación prolongada se realice a una distancia de al menos 5 m.

- I Istruzioni per le operazioni di servizio per l'apparecchio di illuminazione**
GB Instructions on luminaire service operations
F Instructions pour les opérations de service du luminaire
D Wartungsanleitung für die Leuchte
NL Instructies voor de onderhoudsoperaties op de verlichtingsarmatuur
E Instrucciones para las operaciones de servicio del aparato de alumbrado
DK Anvisninger i serviceindgreb på belysningsarmatur
N Anvisninger for betjening av lysapparatet
S Instruktioner för användning av belysningsanordningen
RUS Инструкции по эксплуатации осветительного прибора
CN 照明装置检修操作说明

Sostituire la lampada parzialmente esausta
 Replace the partly exhausted lamp
 Remplacer la lampe partiellement épuisée
 Die teilweise erschöpfte Lampe austauschen
 Vervang de gedeeltelijk lege lamp
 Sustituir la lámpara parzialmente agotada
 Udskift den delvist udtjente pære
 Skifte ut den delvis utbrente lyspæren
 Byt ut den delvis förbrukade lampan
 Замена частично отработанной лампочки
 更换部分老化的灯泡



Spegnimento
 Switch it off
 Extinction
 Ausschaltung
 Uitschakeling
 Apagado
 Slukning
 Slukking
 Släckning
 Выключение
 关灯

Interrompere l'alimentazione dell'apparecchio
 Cut the power supply to the luminaire
 Couper l'alimentation du luminaire
 Stromversorgung der Leuchte unterbrechen
 Onderbreek de voeding van het apparaat
 Interrumpir la alimentación del aparato
 Afbryd armaturets strømforsyning
 Avbryt strømtilførselen til apparatet
 Koppla från anordningens strömförsörjning
 Отключить электропитание прибора
 中断装置供电



Aprire l'apparecchio
 Open the fixture
 Ouvrir le luminaire
 Das Gerät öffnen
 Open het apparaat
 Abrir el aparato
 Åbn armaturet
 Åpne apparatet
 Öppna anordningen
 Раскрыть прибор
 打开装置



Rimuovere la lampada esausta
 Remove the exhausted lamp
 Retirer la lampe épuisée
 Die alte Lampe entnehmen
 Verwijder de lege lamp
 Quitar la lámpara agotada
 Tag den udtjente pære ud
 Fjerne den utbrente lyspæren
 Ta bort den förbrukade lampan
 Вынуть старую лампочку
 取出老化的灯泡

Portarla in un centro di riciclaggio
 Carry it to a recycling centre
 La porter dans une déchetterie pour son recyclage
 Ordnungsgemäß entsorgen
 Breng de lamp naar een recyclingcentrum
 Llevarla a un centro de reciclaje
 Aflever den på en genbrugsstation
 Lever den til en miljøstasjon
 Lämna in den till en återvinningsanläggning
 Сдать ее в пункт приема утильсырья
 将其送往回收中心



Inserire la nuova lampada
 Introduce the new lamp
 Installer la lampe neuve
 Die neue Lampe einsetzen
 Doe de nieuwe lamp op zijn plek
 Montar la nueva lámpara
 Sæt den nye pære i
 Sette i den nye pæren
 Sätt i den nya lampan
 Вставить новую лампочку
 装入新灯泡

Inserire la nuova lampada nel portalampada
 Fit the new lamp into the socket
 Installer la nouvelle lampe dans le support de lampe
 Die neue Lampe in den Sockel einsetzen
 Doe de nieuwe lamp in de lamphouder
 Montar la nueva lámpara en el portalámpara
 Sæt den nye pære i fatningen
 Sette den nye pæren inn i lampeholderen
 Sätt i den nya lampan i lamphållaren
 Вставить новую лампочку в патрон
 将新灯泡插入灯泡架中



Riposizionare ottica
 Re-place the optic
 Remettre l'optique à sa place
 Die Optik wieder einsetzen
 Doe de optiek weer op zijn plaats
 Volver a montar la óptica
 Sæt den optiske enhed på plads
 Innstille linsen
 Flytta om optiken
 Отрегулировать линзы
 重新定位光头



Effettuare prova di funzionamento
 Perform operative test
 Procéder à un essai de fonctionnement
 Eine Funktionsprüfung durchführen
 Controleer de correcte werking
 Hacer una prueba de funcionamiento
 Afprøv funktionen
 Prøve om den fungerer
 Utför funktionstest
 Выполнить проверку исправности работы
 执行功能测试



I Istruzioni per la pulizia dell'apparecchio di illuminazione
GB Instructions on luminaire cleaning operations
F Instructions pour le nettoyage du luminaire
D Anweisungen zur Reinigung der Leuchte
NL Instructies voor de reiniging van de verlichtingsarmatuur
E Instrucciones para limpiar el aparato de alumbrado
DK Anvisninger i rengøring af belysningsarmaturet
N Anvisninger for rengjøring av lysapparatet
S Instruktioner för rengöring av belysningsanordningen
RUS Инструкции по чистке осветительного прибора
CN 照明装置清洁说明

Pulire l'apparecchio
Clean the fixture
Nettoyer le luminaire
Das Gerät reinigen
Reinig het apparaat
Limpiar el aparato
Rengør armaturet
Rengjøre apparatet
Rengör anordningen
Чистка прибора
清洁装置



Spegnimento
Switch it off
Extinction
Ausschaltung
Uitschakeling
Apagado
Slukning
Slukking
Släckning
Выключение
关灯

Interrompere l'alimentazione dell'apparecchio
Cut the power supply to the luminaire
Couper l'alimentation du luminaire
Stromversorgung der Leuchte unterbrechen
Onderbreek de voeding van het apparaat
Interrumpir la alimentación del aparato
Afbryd armaturets strømforstyrning
Avbryt strømtilførselen til apparatet
Koppla från anordningens strömförsörjning
Отключить электропитание прибора
中断装置供电



Spolverare l'ottica esterna
Remove dust from the external optic
Dépoussiérer l'optique extérieure
Die externe Optik abstauben
Stof de externe optiek af
Quitar el polvo de la óptica exterior
Tør støvet af den udvendige optiske enhed
Fjerne støv fra den eksterne lysenheden
Damma av den yttre optiken
Вытереть пыль с внешней стороны линз
为外侧镜头掸尘



Lavare l'ottica esterna
Wash the external optic
Laver l'optique extérieure
Die externe Optik waschen
Was de externe optiek
Lavar la óptica exterior
Vask den udvendige optiske enhed
Vaske den eksterne lysenheden
Rengör den yttre optiken
Вымыть линзы с внешней стороны
清洁外镜头



Rimuovere l'ottica
Remove the optic
Retirer l'optique
Die Optik abnehmen
Verwijder de optiek
Quitar la óptica
Tag den optiske enhed af
Fjerne lysenheden
Ta bort optiken
Снять линзы
取下镜头



Pulire la parte interna dell'apparecchio di illuminazione
Clean the inside of the fixture
Nettoyer l'intérieur du luminaire
Die Innenseite der Leuchte reinigen
Reinig de binnenzijde van de verlichtingsarmatuur
Limpiar el interior del aparato de alumbrado
Rengør belysningsarmaturets indvendige dele
Rengjøre lysapparatet innvendig
Rengör belysningsanordningen invändigt
Протереть осветительный прибор изнутри
清洁照明装置内部



Riposizionare ottica
Re-place the optic
Remettre l'optique à sa place
Die Optik wieder einsetzen
Doe de optiek weer op zijn plaats
Volver a montar la óptica
Sæt den optiske enhed på plads
Innstille linsen
Flytta om optiken
Отрегулировать линзы
重新定位镜头



Effettuare prova di funzionamento
Perform operative test
Procéder à un essai de fonctionnement
Eine Funktionsprüfung durchführen
Controleer de correcte werking
Hacer una prueba de funcionamiento
Afprøv funktionen
Prøve om den fungerer
Utför funktionstest
Выполнить проверку исправности работы
执行功能测试



- I** Istruzioni per il fine vita e lo smaltimento dei componenti
GB Instructions on end-of-life and component disposal
F Instructions pour la gestion des composants en fin de vie et leur mise au rebut
D Anweisungen zur Entsorgung der Leuchtenkomponenten
NL Instructies voor het verwijderen van de armatuur en het recyclen van de onderdelen
E Instrucciones para el final de vida y la eliminación los componentes
DK Anvisninger i udtjent armatur og bortskaffelse af komponenter
N Anvisninger for endt levetid og avfallsbehandling av delene
S Instruktioner vid bortskaffning och kassering av komponenter
RUS Инструкции по утилизации прибора и его комплектующих по окончании его срока службы
CN 寿命期结束与零件废弃处置说明

<p>Spegnimento Switch it off Extinction Ausschaltung Uitschakeling Apagado Slukning Slukking Släckning Выключение 关灯</p> <p>Interrompere l'alimentazione dell'apparecchio Cut the power supply to the luminaire Couper l'alimentation du luminaire Stromversorgung der Leuchte unterbrechen Onderbreek de voeding van het apparaat Interrompirla alimentación del aparato Afbryd armaturets strømforsyning Avbryt strømtilførselen til apparatet Koppla från anordningens strömförsörjning Отключить электропитание прибора 中断装置供电</p> 	<p>Rimuovere la/e lampada/e per la dismissione Remove the lamp(s) for decommissioning Retirer la(les) lampe(s) pour sa(leur) mise au rebut Die Lampe/n ordnungsgemäß entsorgen Verwijder de lamp(en) voor het recyclen Quitar la(s) lámpara(s) para el desecho Tag pæren/pærerne ud til bortskaffelse Fjerne lampen/-e som skal kastes Ta bort lampan/-orna för bortskaffningen Вынуть лампочку/и для утилизации прибора 取出需要丢弃的灯泡</p> 	<p>Rimuovere la batteria per la dismissione Remove the battery for decommissioning Retirer la batterie pour sa mise au rebut Die Batterie ordnungsgemäß entsorgen Verwijder de batterij voor het recyclen Quitar la batería para el desecho Tag batteriet ud til bortskaffelse Fjerne batteriet som skal kastes Ta bort batteriet för bortskaffningen Вынуть батарейку для утилизации прибора 取出需要丢弃的电池</p> 	<p>Rimuovere l'apparecchio per la dismissione Remove the fixture for decommissioning Enlever le luminaire pour sa mise au rebut Das Gerät ordnungsgemäß entsorgen Verwijder het apparaat voor het recyclen Quitar el aparato para el desecho Tag armaturet ud til bortskaffelse Fjerne apparatet som skal kastes Ta bort anordningen för bortskaffningen Снять прибор для утилизации 取出需要丢弃的装置</p> 
---	--	--	--

<p>Inviare i materiali ad un centro di raccolta RAEE Send the materials to a WEEE collection centre Envoyer les matériaux dans une déchetterie DEEE Die Materialien in einem WEEE-Zentrum entsorgen Zend de materialen naar een recyclingscentrum voor de AEEA Enviar los materiales a un centro de recogida RAEE Afløver materialerne på et indsamlingscenter for elektronisk udstyr Sende materialene til en miljøstasjon for resirkulering av EE-avfall Skicka materialet till en RAEE uppsamlingscentral Сдать материалы в пункт приема утильсырья 将材料送往电气和电子垃圾回收中心</p> 			
--	--	--	--