

iPLAN LED incasso/plafone

IT ATTENZIONE:

LA SICUREZZA DELL'APPARECCHIO E' GARANTITA SOLO CON L'USO APPROPRIATO DELLE SEGUENTI ISTRUZIONI; PERTANTO E' NECESSARIO CONSERVARLE.

EN WARNING:

THE SAFETY OF THIS FIXTURE IS GUARANTEED ONLY IF YOU COMPLY WITH THESE INSTRUCTIONS; REMEMBER TO CONSERVE IN A SAFE PLACE.

FR ATTENTION:

LA SECURITE DE L'APPAREIL N'EST GARANTIE QU'EN CAS D'UTILISATION CORRECTE DES INSTRUCTIONS SUIVANTES; IL FAUT PAR CONSEQUENT LES CONSERVER.

DE ACHTUNG:

DIE SICHERHEIT DES GERÄTES WIRD NUR DURCH SACHGEMÄSSE BEFOLGUNG NACHSTEHENDER ANWEISUNGEN GEWÄHRLEISTET; IHRE AUFBEWAHRUNG IST DESHALB SEHR WICHTIG.

NL OPGELET:

DE VEILIGHEID VAN DI ATOESTEL IS SLECHTS DAN GEGARANDEERD ALS INDIEN DE VOLGENDE INSTRUCITIES STRIKT WORDEN TOEGEPAST: DAAROM MOET MEN ZE OOK BEWAREN.

ES ATENCION:

LA SEGURIDAD DEL APARATO SE GARANTIZA SOLO CUMPLIENDO CUIDADOSAMENTE LAS SIGUIENTES INSTRUCCIONES; POR ELLO, ES NECESARIO CONSERVARLAS.

DA BEMÆRK:

SIKKERHEDEN VED BRUG AF ARMATURET KAN KUN GARANTERES, HVIS DISSE ANVISNINGER FØLGES; SØRG DERFOR FOR AT GEMME DEM.

NO ADVARSEL:

SIKKERHETEN TIL DETTE APPARATET GARANTERES KUN HVIS DU OVERHOLDER DISSE INSTRUKSJONENE; HUSK Å OPPBEVARE DEM PÅ ET TRYGT STED.

SV OBSERVERA!

UTRUSTNINGENS SÄKERHET KAN ENDAST GARANTERAS OM DESSA ANVISNINGAR RESPEKTERAS I DETALJ. SPARA DÄRFÖR DESSA ANVISNINGAR FÖR FRAMTIDA KONSULTATION.

RU ВНИМАНИЕ:

МЫ ГАРАНТИРУЕМ БЕЗОПАСНУЮ ЭКСПЛУАТАЦИЮ ИЗДЕЛИЯ ТОЛЬКО ПРИ СОБЛЮДЕНИИ СЛЕДУЮЩИХ ИНСТРУКЦИЙ; С ЭТОЙ ЦЕЛЬЮ НЕОБХОДИМО СОХРАНИТЬ ДАННУЮ БРОШЮРУ.

ZH 警告

为确保该装置安全, 请遵守操作指示; 并于安全场所放置。

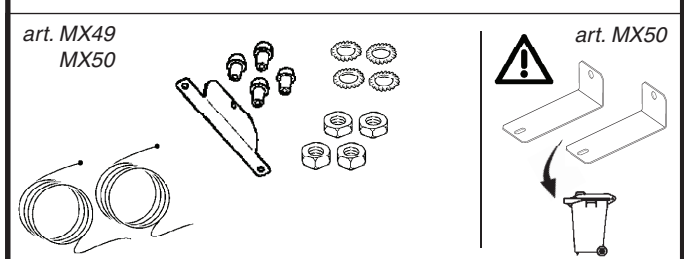
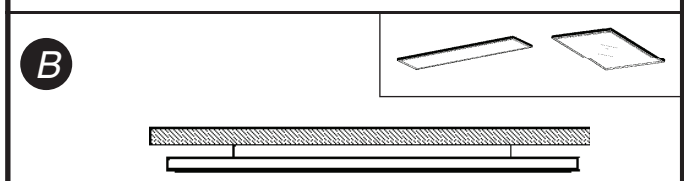
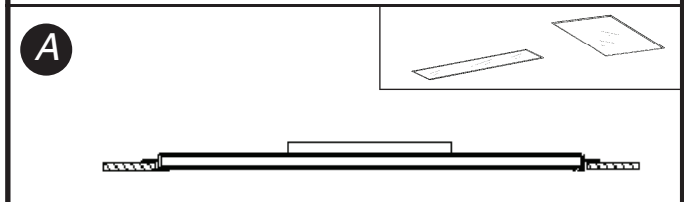
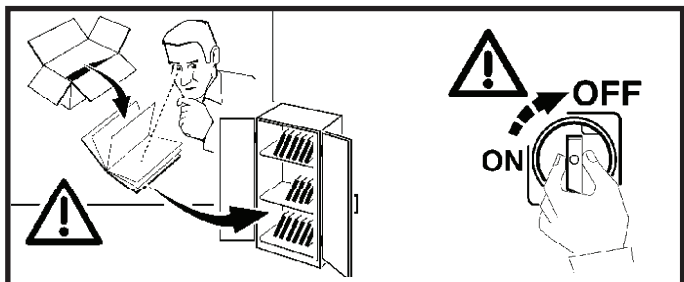
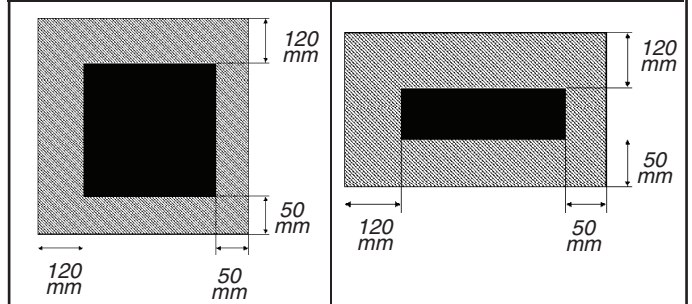
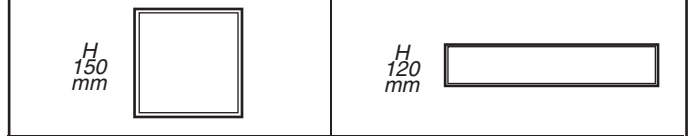
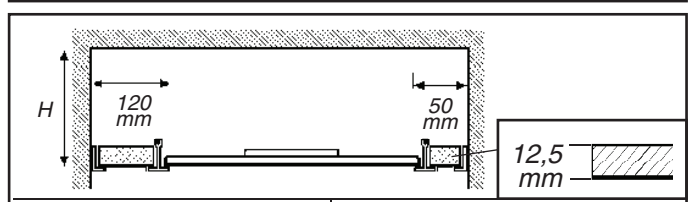
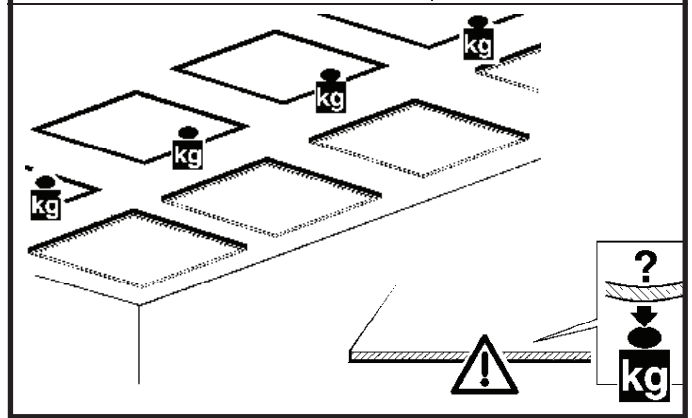
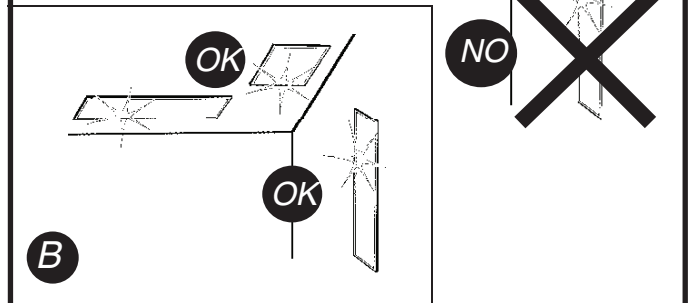
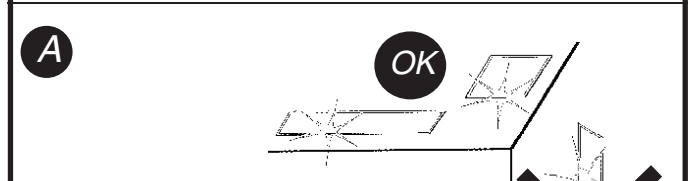
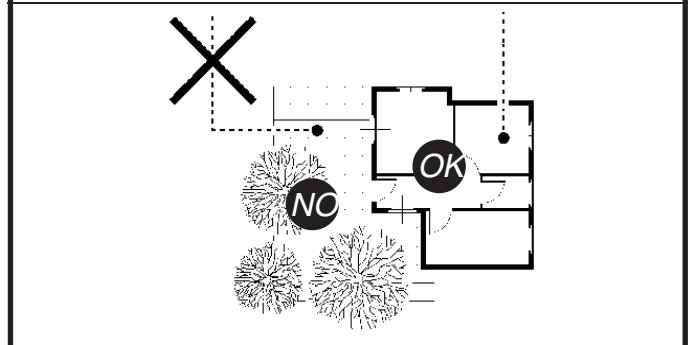
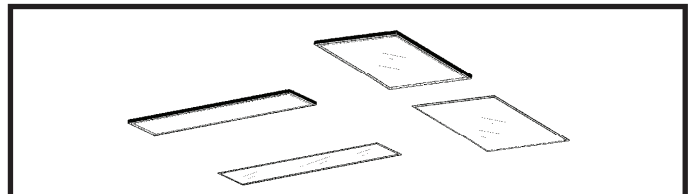

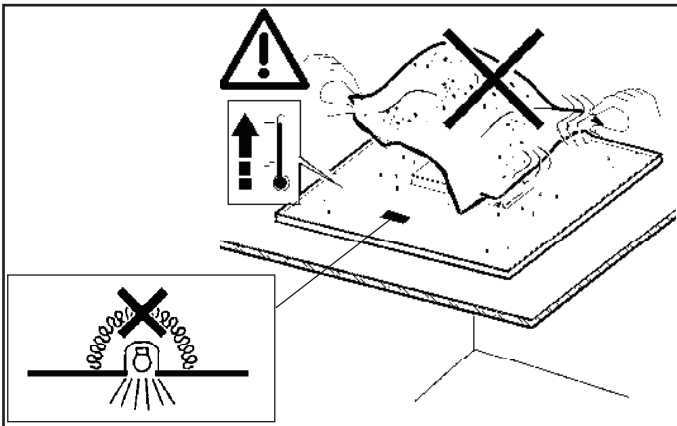

IT N.B.: Apparecchi non idonei ad essere coperti di materiale termicamente isolante.
 EN N.B.: Fixtures not suitable to be covered in thermally-insulating material.
 FR N.B.: Appareils ne pouvant pas être couverts de matériau d'isolation thermique.
 DE N.B.: Geräte nicht geeignet, um mit wärmeisolierendem Material abgedeckt zu werden.
 NL N.B.: Deze apparaten zijn niet geschikt om te worden bedekt met thermisch isolerend materiaal.
 ES NOTA: Aparatos no aptos para ser cubiertos de material térmicamente aislante.
 DA N.B.: Armaturerne må ikke dækkes af varmeisolerende materiale.
 NO N.B.: Apparatene passer ikke til å dekkes av termoisolerende materialer.
 SV OBS! Utrustningen får inte täckas över med värmeisolerande material.
 RU Приспособия не пригодны для покрытия термоизоляционными материалами.
 ZH 灯具不适宜用隔热材料加以覆盖。

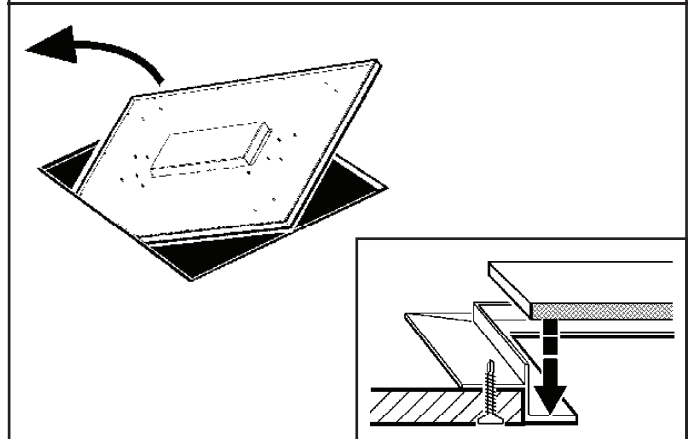
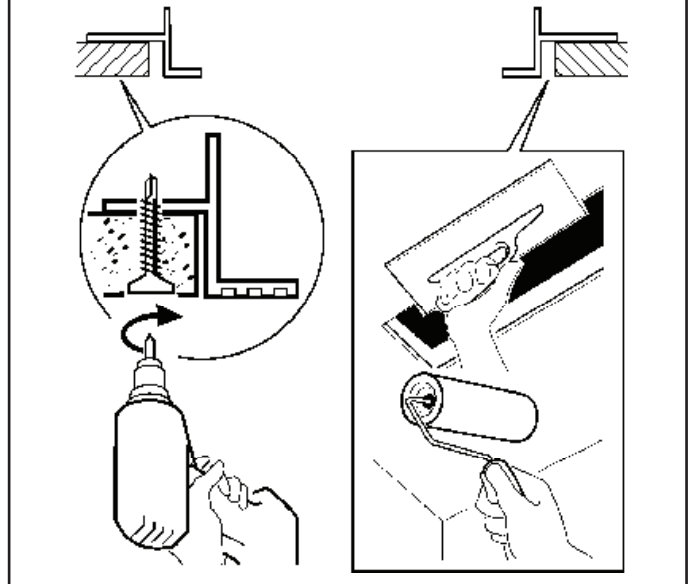
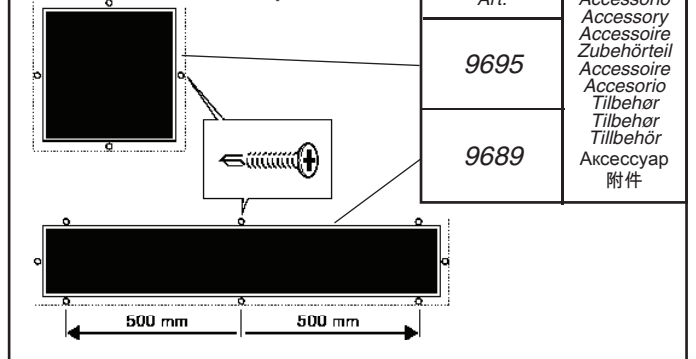
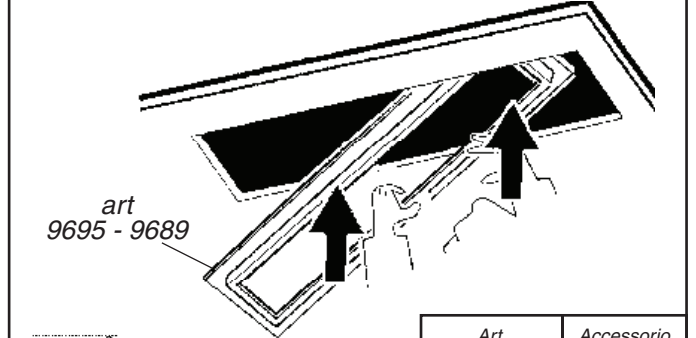
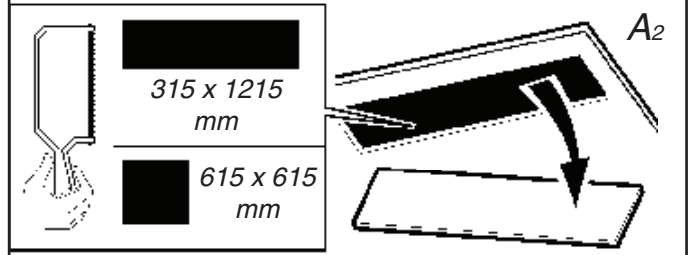
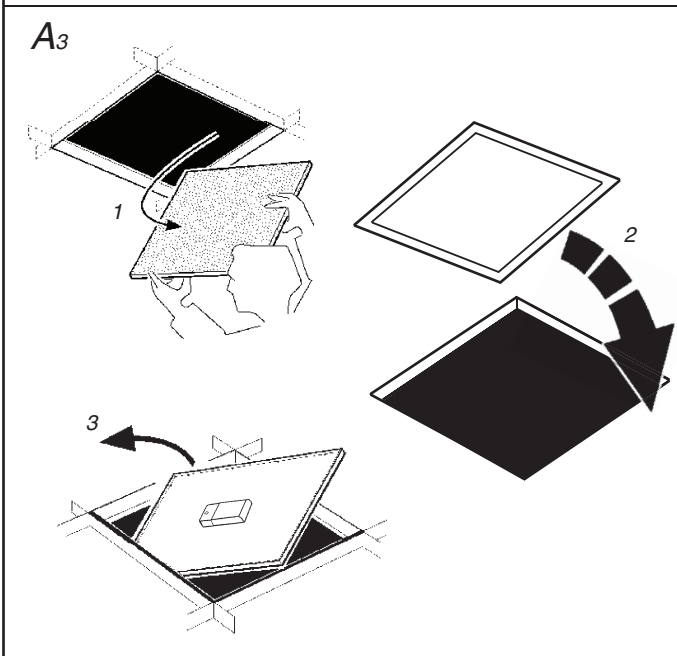
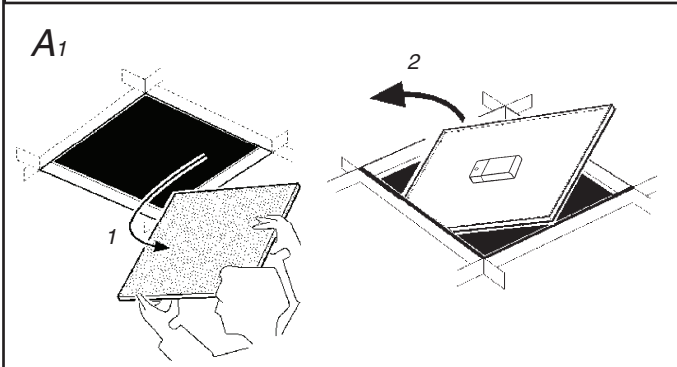
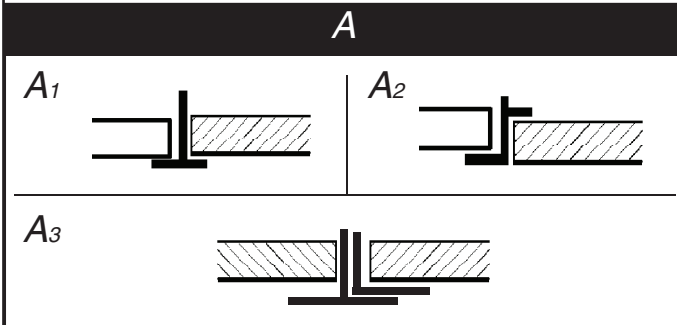



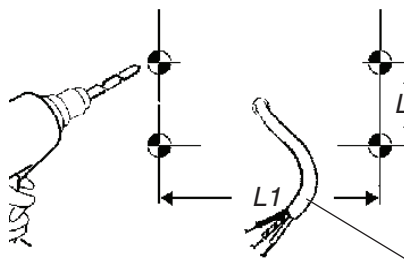

B

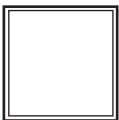

ALIMENTAZIONE
POWER SUPPLY
ALIMENTATION
EINSPEISUNG
STROOMVERZORGING
ALIMENTACION
STRÖMFORSYNING
STRÖMFORSYNING
ELFÖRSÖRJNING
ЭЛЕКТРОПИТАНИЕ
电源

ART	L1 mm	L2 mm
art. MX49 	340	240
art. MX50 	820	65

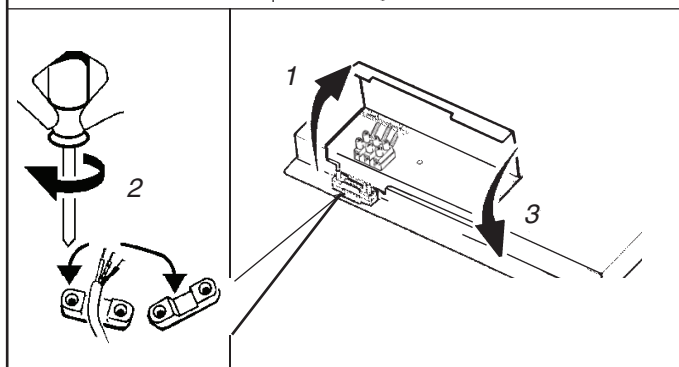
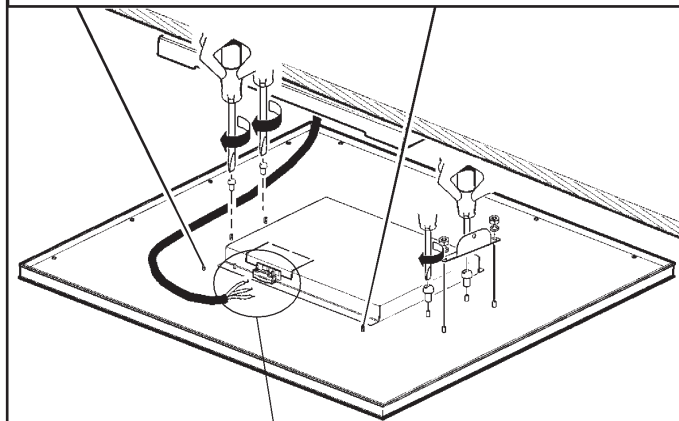
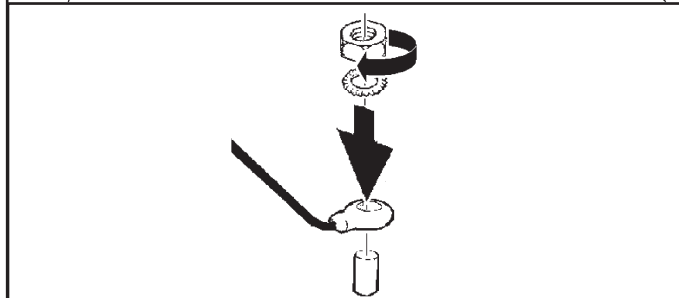
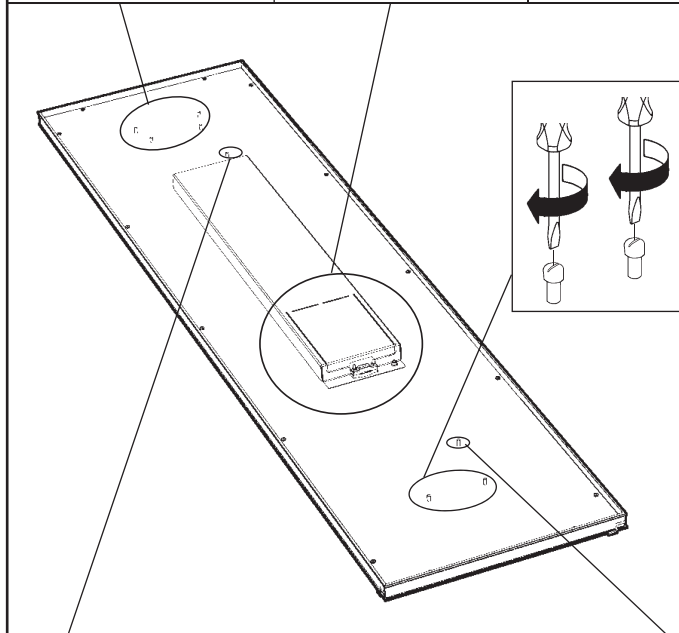
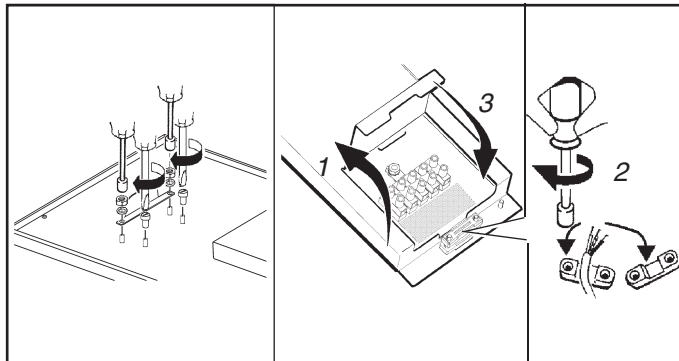
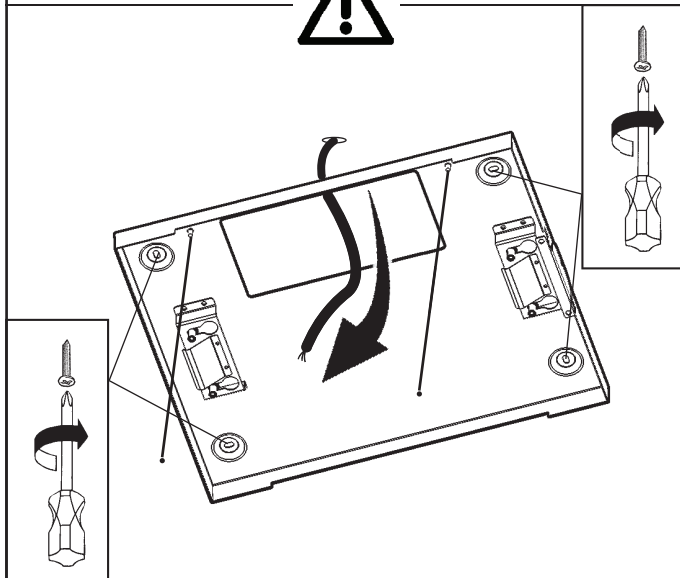
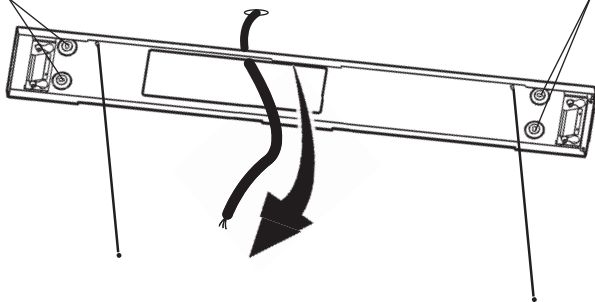
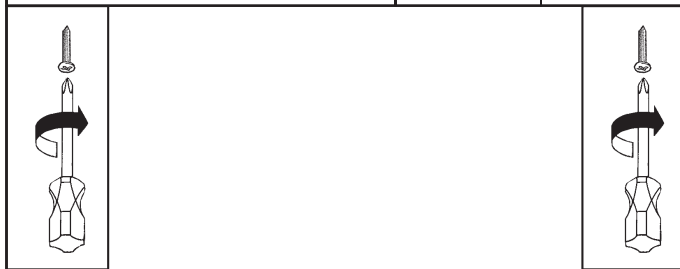

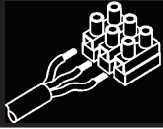

art. ME84 - ME85 - N265 - N266
ME92 - ME93 - N269 - N270

ALIMENTAZIONE
POWER SUPPLY
ALIMENTATION
EINSPEISUNG
STROOMVERZORGING
ALIMENTACION
STRØMFORSYNING
STRØMFORSYNING
ELFØRSØRJNING
ЭЛЕКТРОПИТАНИЕ

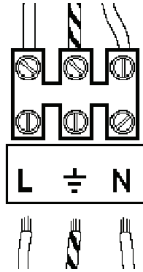
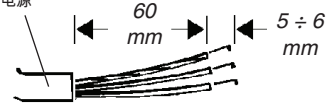

art. ME86 - ME87 - N267 - N268 - N253 - N254
ME94 - ME95 - N271 - N272 - N255 - N256
P172 - P173 - P174 - P175 - P176 - P177

ALIMENTAZIONE
POWER SUPPLY
ALIMENTATION
EINSPEISUNG
STROOMVERZORGING
ALIMENTACION
STRØMFORSYNING
STRØMFORSYNING
ELFØRSØRJNING
ЭЛЕКТРОПИТАНИЕ

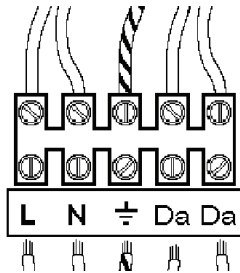
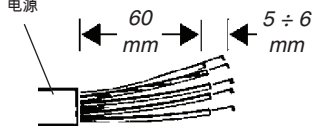

IT NON MODIFICARE I PARAMETRI DELL'ALIMENTATORE DALI IMPOSTATI DALLA "iGuzzini"

EN DO NOT CHANGE THE DALI POWER-UNIT PARAMETERS SET BY "iGuzzini"

FR NE PAS MODIFIER LES PARAMÈTRES DU BALLAST DALI DÉFINIS PAR «IGUZZI-NI»

DE DIE VON „iGuzzini“ EINGESTELLTEN PARAMETER DES DALI-NETZTEILS DÜRFEN NICHT VERÄNDERT WERDEN

NL NIET DE PARAMETERS VAN HET DALI-VOORSCHAKELAPPARAATWIJZIGEN DIE DOOR "iGuzzini" ZIJN INGESTELD

ES NO CAMBIAR LOS PARÁMETROS DEL ALIMENTADOR DALI PROGRAMADOS POR "iGuzzini"

NO FORETAGIKKEÆNDRINGERPÅPARAMETRENE FOR DALISTRØMFORSYNINGSENHEDENINDSTILLET AF" iGuzzini "

DA PARAMETRENE SOM ER LAGT INN I DALI STRØMFORSYNINGSENHETEN FRA "iGuzzini" MÅ IKKE ENDRES

SV ÄNDRA INTE PARAMETRARNA FÖR REAKTORN DALI SOM HAR STÄLLTS IN AV iGuzzini

RU НЕ ИЗМЕНЯТЬ ПАРАМЕТРЫ БЛОКА ПИТАНИЯ, ЗАДАННЫЕ НА ЗАВОДЕ "iGuzzini"

ZH 请勿改变 "iGuzzini" 设置的 DALI (数字可寻址照明接口) 电源装置参数

B

art. MX49
MX50

3

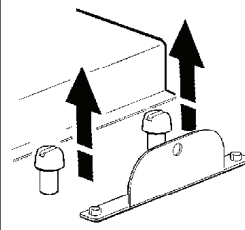

4

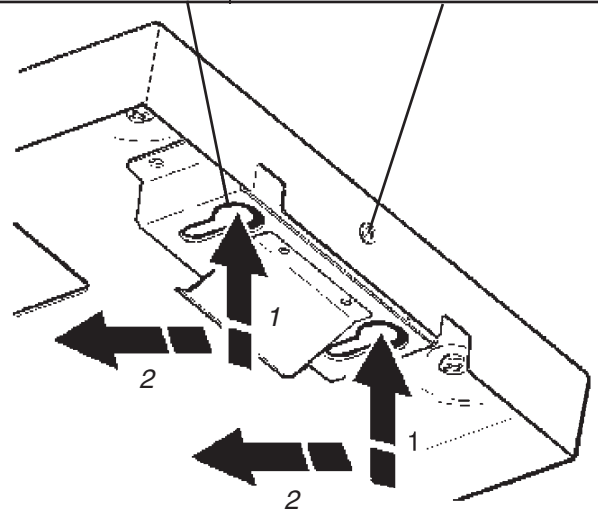
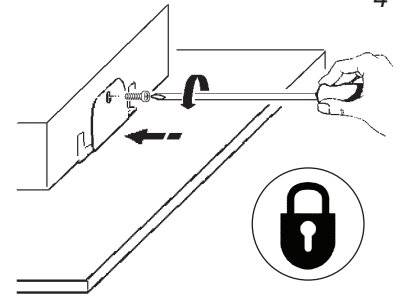

art. MX50

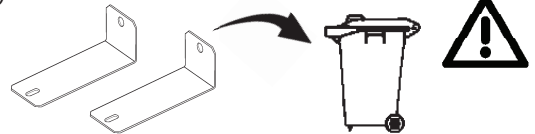

PUSH DIM

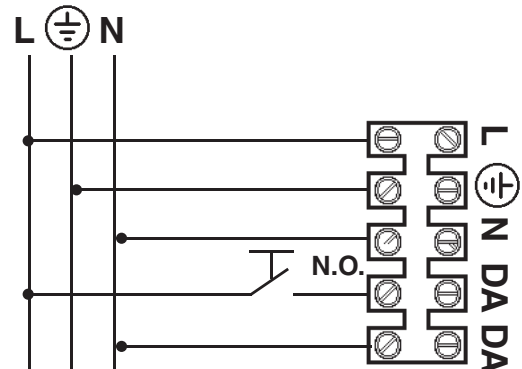
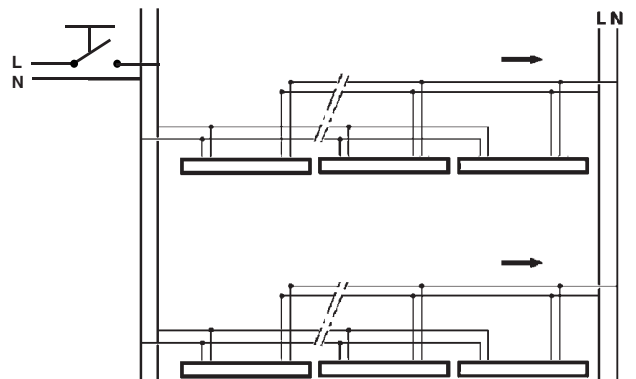

IT I dispositivi con cablaggio digitale possono essere dimmerati con dispositivi DALI o con pulsante normalmente aperto (N.O.) da collegare come da schema.

EN Devices with digital control gear may be dimmed using DALI devices or a normally-open button (N.O.) to be connected as shown in the diagram.

FR Les articles à câblage numérique peuvent fonctionner avec des variateurs à dispositifs DALI ou à bouton poussoir normalement ouvert (N.O.) à relier conformément au schéma.

DE Die Geräte mit digitaler Verkabelung können mit Hilfe von DALI-Vorrichtungen oder mit Hilfe eines gemäß Schaltplan anzuschließenden Schließers (N.O.) gedimmt werden.

NL De producten met digitale bekabeling kunnen worden gedimd met DALI systemen of met een N.O. (normally open) knop, die moet worden aangesloten volgens schema.

ES Los dispositivos con cableado digital pueden regularse con dispositivos DALI o con un interruptor de botón normalmente abierto (N.O.) que se conecta según ilustrado en el esquema.

DA Produkter med digital kabelføring kan dæmpes med DALI-anordninger eller med kontakten, som normalt er åben (N.O.) og som skal tilsluttes, som vist.

NO Produkter med digitalkabler kan dimmes med DALI-anordninger eller med en normalt åpen (NO) trykkbryter som kobles som vist i koblingsskjema.

SV Produkter med digital kabeldragning kan förses med dimmer. Detta kan göras med DALI-anordningarna eller med en normalt öppen kontakt (N.O.) som ska anslutas enligt schemat.

RU Интенсивность приборов с цифровой проводкой может регулироваться посредством устройств DALI или нормально разомкнутой кнопкой (Н.Р.), подсоединяемой согласно схеме.

ZH 带有数字控制装置的设备可以通过 DALI (数字化可寻址调光接口) 设备或者一个连接方式如图中所示的常开按钮 (N.O.) 进行亮度调节

IT Pilotare diversi prodotti DALI tramite pulsante (es: Touch-dim, Switch-dim, Push-dim, Direct-dim, etc.) potrebbe causare dei problemi di sincronizzazione tra gli stessi. È possibile ovviare a questo problema dotandosi di dispositivi aggiuntivi. Per maggiori informazioni vi invitiamo a contattarci direttamente.

EN Controlling different DALI products through buttons (e.g.: Touch-dim, Switch-dim, Push-dim, Direct-dim, etc.) may lead to product synchronisation problems. This problem can be overcome by using additional devices. For further information, please contact us directly.

FR Piloter plusieurs produits DALI par bouton (ex : Touch-dim, Switch-dim, Push-dim, Direct-dim, etc.) pourrait causer des problèmes de synchronisation entre eux. Ce problème peut être évité en s'équipant de dispositifs supplémentaires. Pour de plus amples renseignements, veuillez nous contacter directement.

DE Die Steuerung verschiedener DALI-Produkte mittels Taste (z.B.: Touch-dim, Switch-dim, Push-dim, Direct-dim etc.) kann eventuell zu Synchronisierungsproblemen zwischen diesen führen. Dieses Problem lässt sich durch den Einsatz von zusätzlichen Geräten beheben. Wenn Sie weitere Informationen wünschen, setzen Sie sich bitte direkt mit uns in Verbindung.

NL Het besturen van verschillende DALI producten m.b.v. dezelfde knop (bv.: Touch-dim, Switch-dim, Push-dim, Direct-dim, etc.) kan synchronisatieproblemen tussen de producten opleveren. Men kan dit probleem voorkomen door extra systemen aan te sluiten. Voor verdere informatie raden we u aan direct contact met ons op te nemen.

ES El mando de varios productos DALI por tecla (ej: Touch-dim, Switch-dim, Push-dim, Direct-dim, etc.) podría causar problemas de sincronización entre ellos. Es posible prevenir este problema utilizando dispositivos adicionales. Para más información, contacte directamente con nosotros.

DA Hvis DALI-produkterne styres ved hjælp af knapperne (fx. Touch-dim, Switch-dim, Push-dim, Direct-dim osv.), kan det skabe problemer med synkronisering af samme. Dette problem kan undgås, hvis man køber ekstra enheder. For yderligere oplysninger, kontakt os direkte.

NO Å styre ulike DALI-produkter ved hjelp av en trykknappbryter (f.eks. touch-dim, switch-dim, push-dim, direct-dim, osv.) vil kunne føre til problemer med synkroniseringen mellom dem. Dette problemet kan løses ved hjelp av noen tilleggsinnretninger. Ta gjerne kontakt med oss for mer informasjon om dette.

SV Styrning av olika DALI-produkter med knapp (t.ex.: Touch-dim, Switch-dim, Push-dim, Direct-dim o.s.v.) kan orsaka synkroniseringsproblem mellan dessa. Detta problem kan åtgärdas med tilläggsanordningar. För mer information kan du kontakta oss direkt.

RU Управление различными продуктами DALI с помощью кнопки (напр.: Touch-dim, Switch-dim, Push-dim, Direct-dim и пр.) может вызвать проблемы синхронизации между ними. Эту проблему можно устранить путем задействования дополнительных устройств. За получением более подробной информации просим Вас связаться с нами непосредственно.

ZH 通过按钮控制不同的 DALI 产品 (例如: 触摸调光、切换调光、按压调光、直接调光等) 可能会导致产品的同步问题。该问题可通过使用其他额外的装置加以克服。如需了解更多信息, 请直接与我们联系。

ART.	PESO WEIGHT POID GEWICHT GEWICHT PESO - VÆGT VEKT - VIKT BEC - 重量 (Kg)
ME84 - ME85 - ME86 - ME87	7
N253 - N254 - N265 - N266 - N267 - N268	7,8
ME92 - ME93 - ME94 - ME95	7,2
N255 - N256 - N269 - N270 - N271 - N272	8
MX49 - MX50	1,4
MX76	1,2
P172 - P173	8,2
P174 - P175 - P176 - P177	9

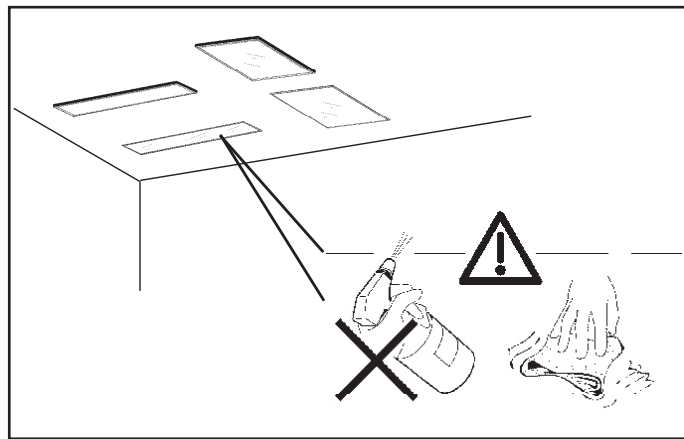

IT N.B.: Per la sostituzione del LED contattare l'azienda iGuzzini.

EN N.B.: For information on LED replacement please contact iGuzzini.

FR N.B.: Pour procéder au remplacement de la LED, adressez-vous à la société iGuzzini.

DE N.B.: Bezüglich des Austausches der LED kontaktieren Sie bitte die Firma iGuzzini.

NL N.B.: Voor het vervangen van de LED neemt u contact op met het bedrijf iGuzzini.

ES NOTA: Para sustituir el LED llame a la empresa iGuzzini.

DA N.B.: For udskiftning af lysdioden, skal man kontakte iGuzzini.

NO N.B.: For informasjon om skifte av LED, vennligst ta kontakt med iGuzzini.

SV OBS! För byte av lysdioden, kontakta företaget iGuzzini.

RU ПРИМЕЧАНИЕ: Для замены СИДов обращайтесь в компанию iGuzzini.

ZH 注意: 如需LED更换的信息, 请联系iGuzzini。

IT N.B.: DURANTE L'INSTALLAZIONE DEL SISTEMA RISPETTARE SCRUPolosAMENTE LE NORME IMPIANTISTICHE VIGENTI.

EN N.B.: WHEN INSTALLING THE SYSTEM, STRICTLY COMPLY WITH ALL REGULATIONS ON INSTALLATION IN FORCE.

FR N.B.: LORS DE L'INSTALLATION DU SYSTÈME VEUILLEZ RESPECTER RIGOREUSEMENT LES NORMES EN VIGUEUR EN LA MATIÈRE.

DE NB: BEACHTEN SIE BEI DER INSTALLATION DES SYSTEMS GEWISSENHAFT DIE GÜLTIGEN BESTIMMUNGEN BEZÜGLICH DER ANLAGENTECHNIK.

NL N.B.: BIJ HET INSTALLEREN VAN HET SYSTEEM MOET U DE GELDEN DE INSTALLATIENORMEN STRIKT NALEVEN.

ES N.B.: DURANTE LA INSTALACIÓN DEL SISTEMA RESPETAR E SCRUPULOSAMENTE LAS NORMAS DE INSTALACIÓN VIGENTES.

DA N.B.: UNDER INSTALLATION AF SYSTEMET SKAL MAN NOJE OVERHOLDE DE GÆLDENDE REGLER FOR DISSE ANLÆG.

NO N.B.: VED INSTALLASJON AV SYSTEMET SKAL ALLE FORSKRIFTER OM INSTALLASJON SOM GJELDER FØLGES STRENGT.

SV OBS! UNDER INSTALLATIONEN AV SYSTEMET SKA INSTALLATIONSFÖRESKRIFTERNA RESPEKTERAS I DETALJ.

RU ПРИМЕЧАНИЕ: В ПРОЦЕССЕ МОНТАЖА СИСТЕМЫ СТРОГО СОБЛЮДАЙТЕ НАЦИОНАЛЬНЫЕ ДЕЙСТВУЮЩИЕ НОРМАТИВЫ ПО ЭЛЕКТРОПРОВОДКЕ.

ZH 注意: 在安装系统时请遵守设备的安装规定。



iPLAN LED incasso/plafone

AR

تحذير:

لا يمكن ضمان سلامة هذا الجهاز إلا إذا التزمت بهذه التعليمات، يجب حفظها في مكان آمن.

IT ATTENZIONE:

LA SICUREZZA DELL'APPARECCHIO E' GARANTITA SOLO CON L'USO APPROPRIATO DELLE SEGUENTI ISTRUZIONI; PERTANTO E' NECESSARIO CONSERVARLE.

EN WARNING:

THE SAFETY OF THIS FIXTURE IS GUARANTEED ONLY IF YOU COMPLY WITH THESE INSTRUCTIONS; REMEMBER TO CONSERVE IN A SAFE PLACE.

ES ATENCION:

LA SEGURIDAD DEL APARATO SE GARANTIZA SOLO CUMPLIENDO CUIDADOSAMENTE LAS SIGUIENTES INSTRUCCIONES; POR ELLO, ES NECESARIO CONSERVARLAS.

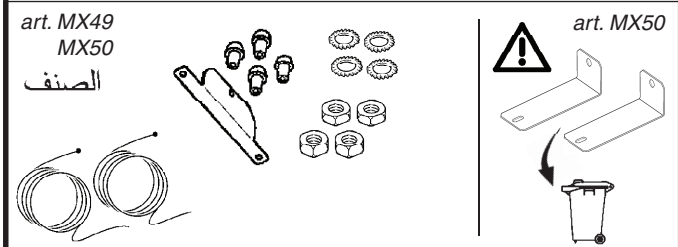
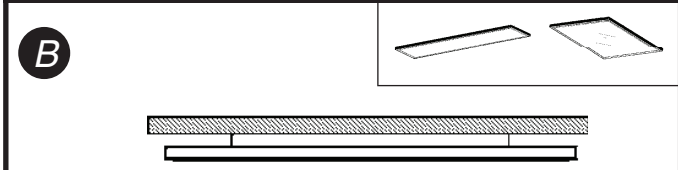
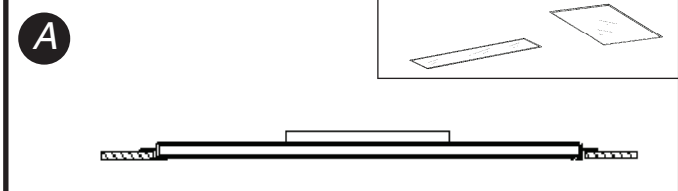
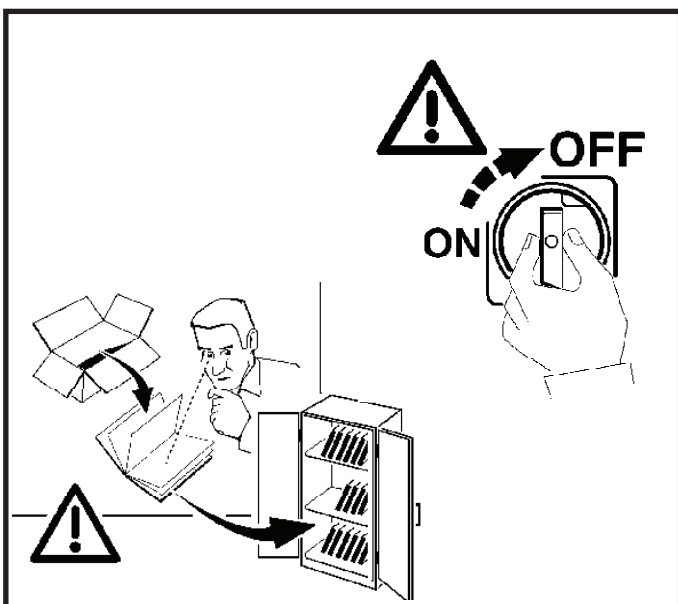
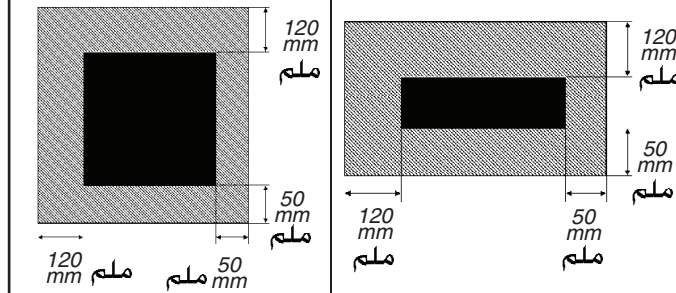
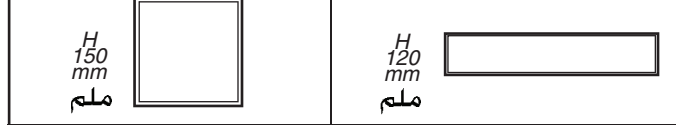
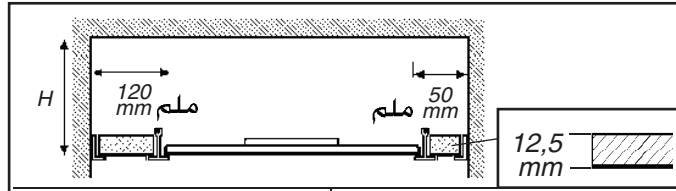
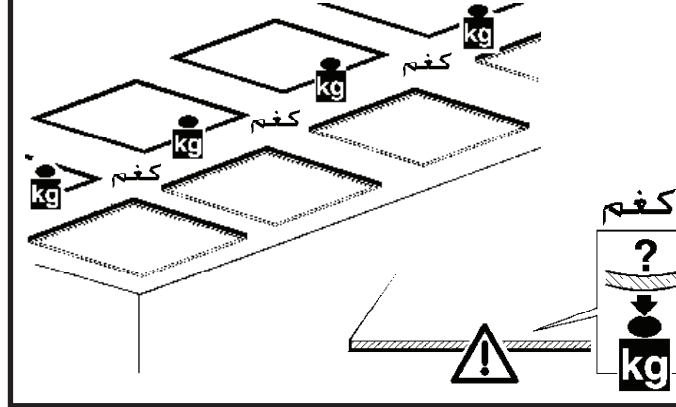
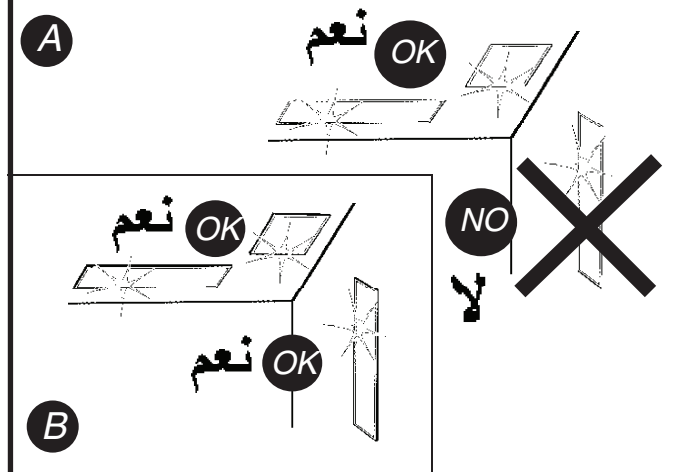
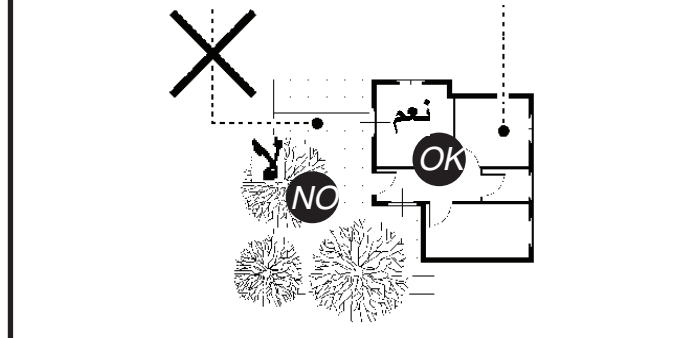
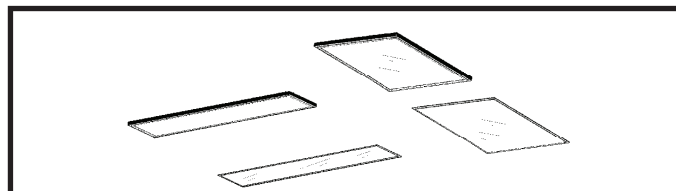

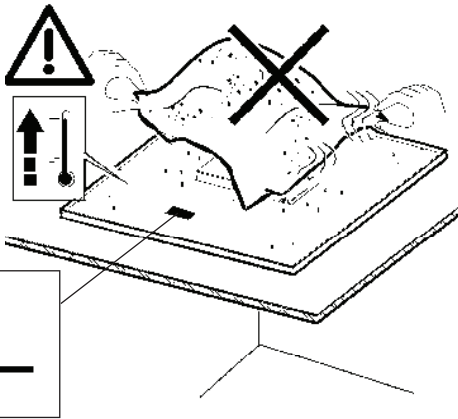
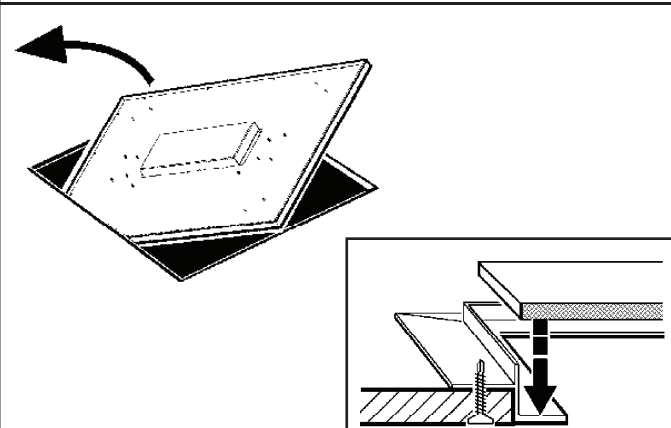
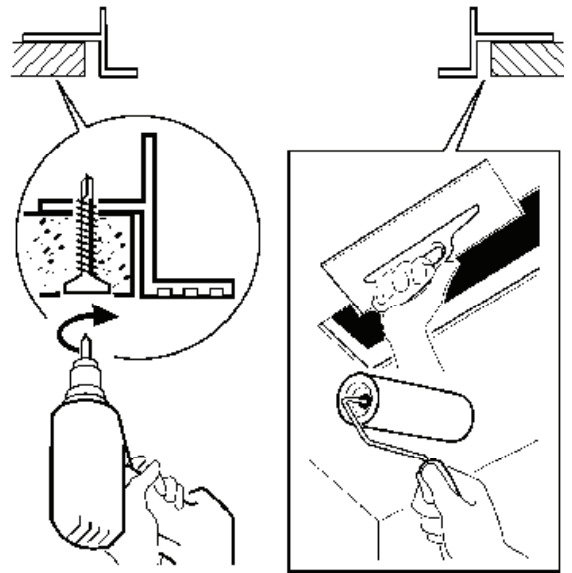
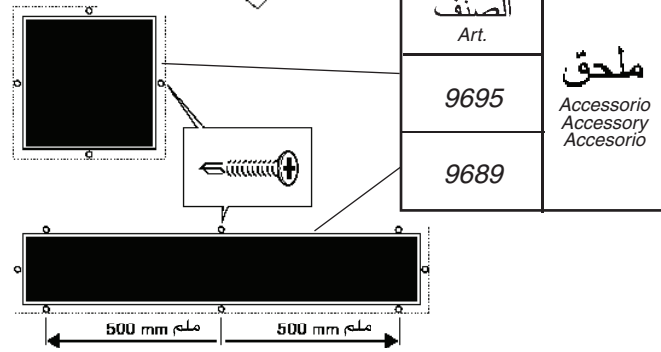
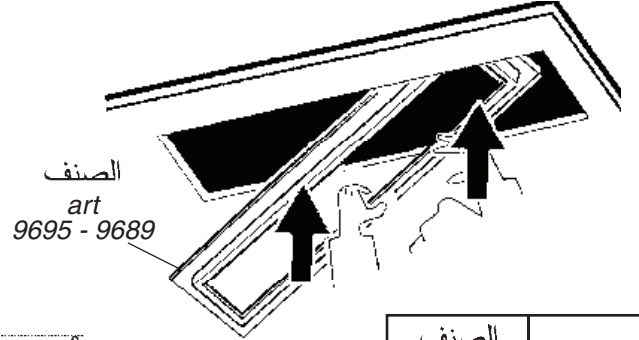
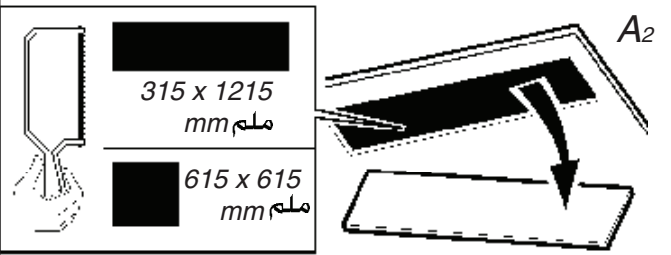

AR ملاحظة: أجهزة غير قابلة للتغطية بمواد عازلة حرارياً.

IT N.B.: Apparecchi non idonei ad essere coperti di materiale termicamente isolante.

EN N.B.: Fixtures not suitable to be covered in thermally-insulating material.

ES NOTA: Aparatos no aptos para ser cubiertos de material térmicamente aislante.

A

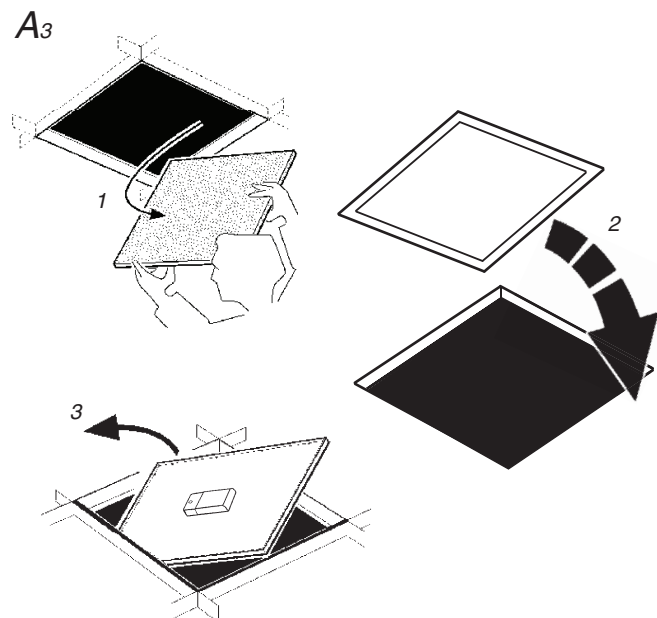
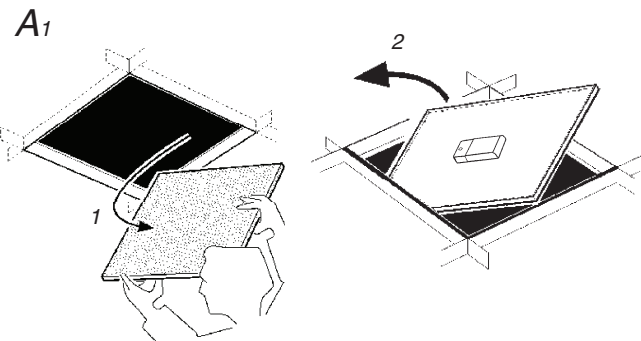
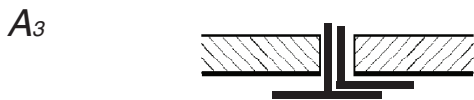

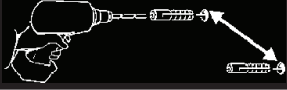

B

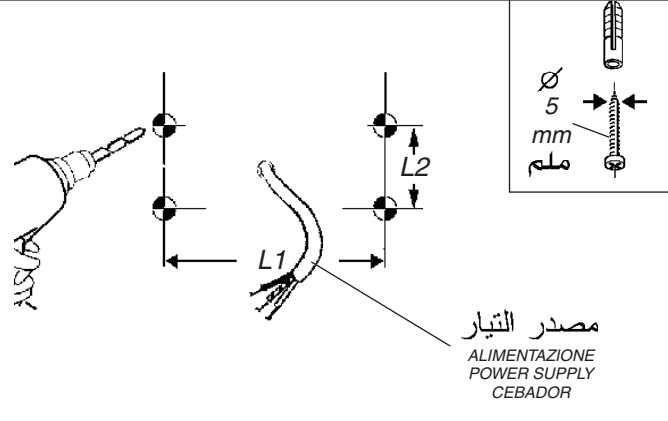

الصنف ART	L1 mm ملم	L2 mm ملم
art. MX49 	340	240
art. MX50 	820	65

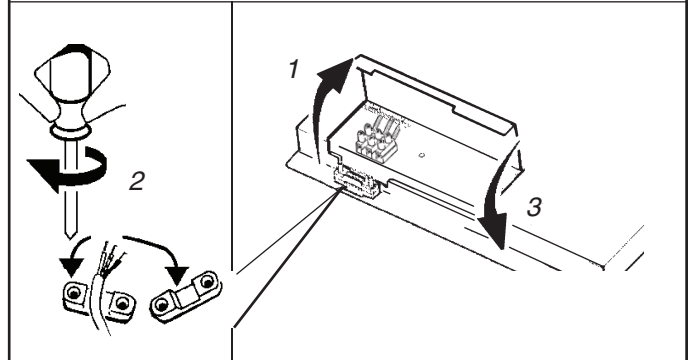
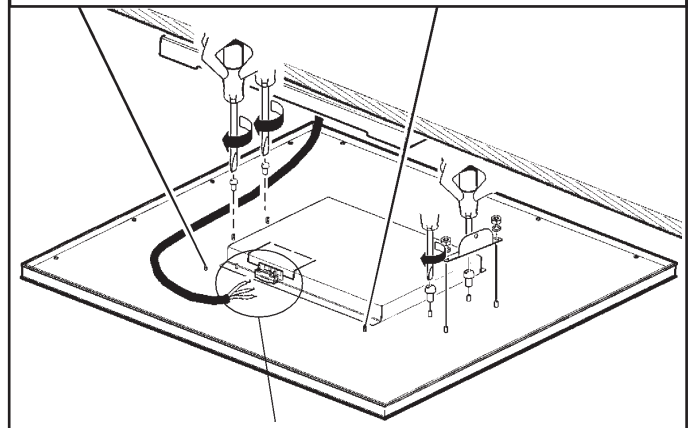
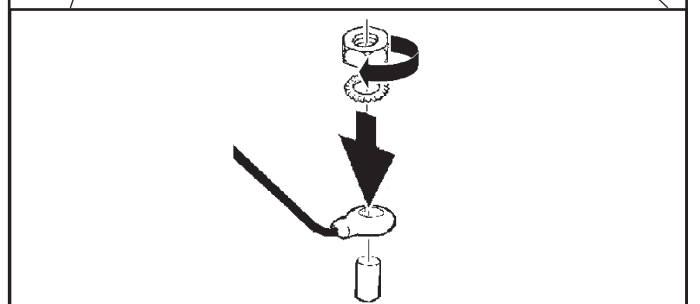
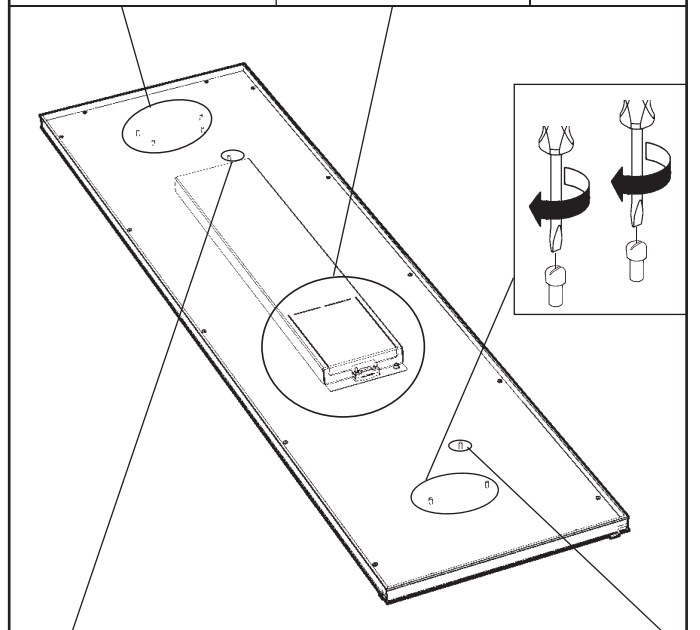
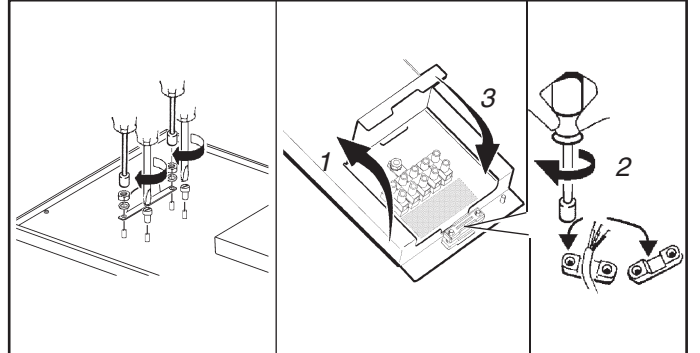
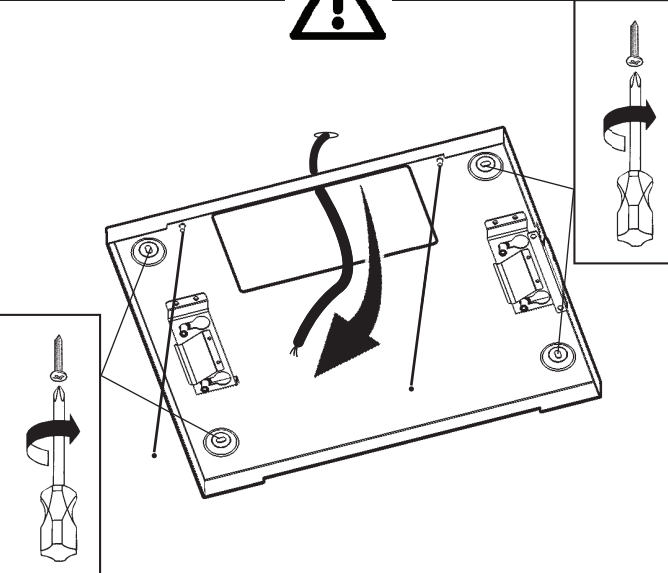
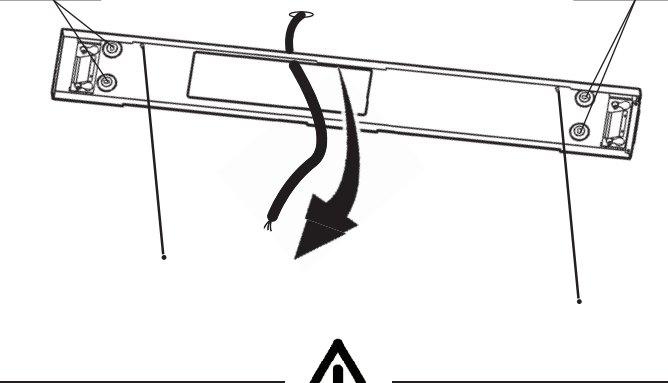
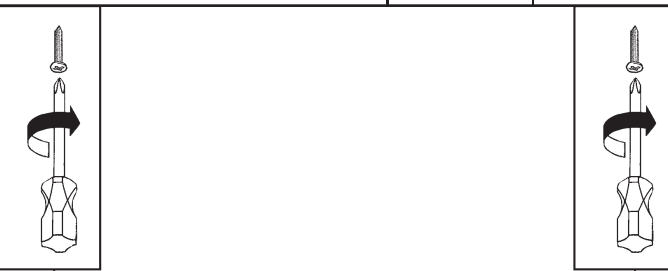



الصف art. ME84 - ME85 - N265 - N266
ME92 - ME93 - N269 - N270

مصدر التيار

ALIMENTAZIONE
POWER SUPPLY
CEBADOR

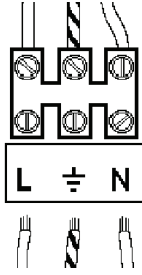
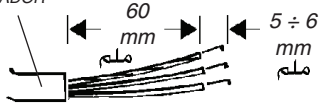

الصف art. ME86 - ME87 - N267 - N268 - N253 - N254
ME94 - ME95 - N271 - N272 - N255 - N256
P172 - P173 - P174 - P175 - P176 - P177

مصدر التيار

ALIMENTAZIONE
POWER SUPPLY
CEBADOR

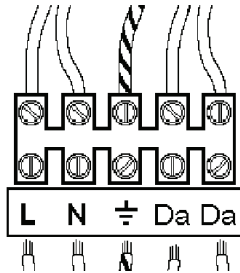
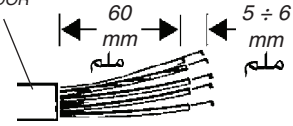

AR لا يجب تغيير معيار التركيب الخاصة بوحدة التغذية المعينة بواسطة "iGuzzini"

IT NON MODIFICARE I PARAMETRI DELL'ALIMENTATORE DALI IMPOSTATI DALLA "iGuzzini"

EN DO NOT CHANGE THE DALI POWER-UNIT PARAMETERS SET BY "iGuzzini"

ES NO CAMBIAR LOS PARÁMETROS DEL ALIMENTADOR DALI PROGRAMADOS POR "iGuzzini"

B

art. MX49
MX50

3

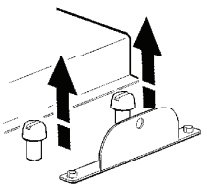

4

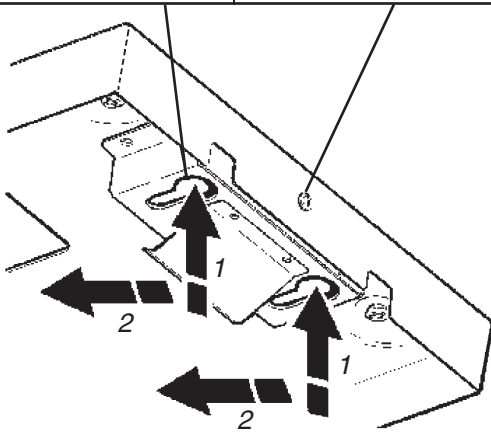
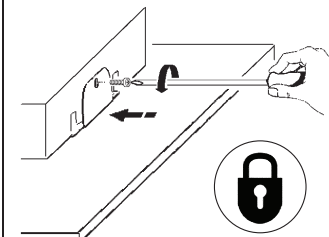

art. MX50

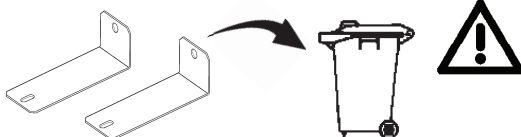

PUSH DIM

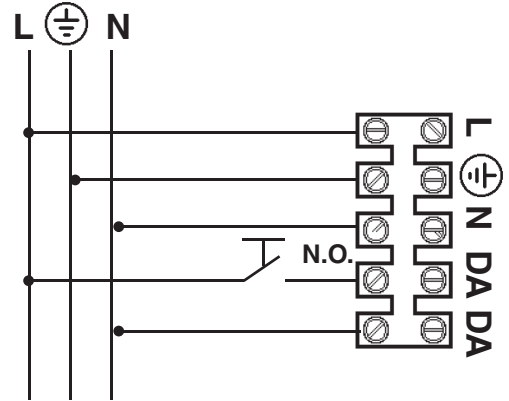
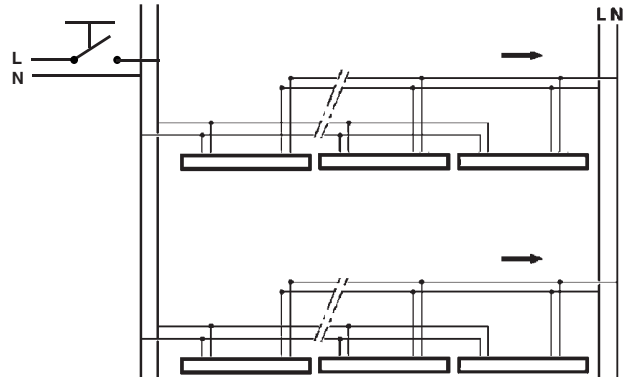

AR التجهيزات المزودة بكابلات رقمية يُمكن وضع مخفضات لها بإضافة تجهيزات DALI أو مفتاح مضبوط على الوضع عامل عادة (N.O.) والذي يتم توصيله كما موضح في المخطط.

IT I dispositivi con cablaggio digitale possono essere dimmerati con dispositivi DALI o con pulsante normalmente aperto (N.O.) da collegare come da schema.

EN Devices with digital control gear may be dimmed using DALI devices or a normally-open button (N.O.) to be connected as shown in the diagram.

ES Los dispositivos con cableado digital pueden regularse con dispositivos DALI o con un interruptor de botón normalmente abierto (N.O.) que se conecta según ilustrado en el esquema.

AR يمكن أن يتسبب التحكم في منتجات "دالي" المختلفة عن طريق الأزرار ، (مثل الأزرار : "تتش - ديم"، "سويتش - ديم"، "بوش - ديم"، "دايركت - ديم"، إلخ) ، في حدوث مشاكل تتعلق بعملية التزامن بين هذه الأزرار . وإن كان من الممكن تجنب مثل هذه المشاكل ، وذلك عن طريق تزويد بعض الأجهزة الإضافية ندعوكم للاتصال المباشر بالشركة ، وذلك للحصول على أكبر قدر من المعلومات.

IT Pilotare diversi prodotti DALI tramite pulsante (es: Touch-dim, Switch-dim, Push-dim, Direct-dim, etc.) potrebbe causare dei problemi di sincronizzazione tra gli stessi. È possibile ovviare a questo problema dotandosi di dispositivi aggiuntivi. Per maggiori informazioni vi invitiamo a contattarci direttamente.

EN Controlling different DALI products through buttons (e.g.: Touch-dim, Switch-dim, Push-dim, Direct-dim, etc.) may lead to product synchronisation problems. This problem can be overcome by using additional devices. For further information, please contact us directly.

ES El mando de varios productos DALI por tecla (ej: Touch-dim, Switch-dim, Push-dim, Direct-dim, etc.) podría causar problemas de sincronización entre ellos. Es posible prevenir este problema utilizando dispositivos adicionales. Para más información, contacte directamente con nosotros.

الصف
ART.

الوزن
Peso
Weight
Peso
كغم
(Kg)

ME84 - ME85 - ME86 - ME87

7

N253 - N254 - N265 - N266 - N267 - N268

7,8

ME92 - ME93 - ME94 - ME95

7,2

N255 - N256 - N269 - N270 - N271 - N272

8

MX49 - MX50

1,4

MX76

1,2

P172 - P173

8,2

P174 - P175 - P176 - P177

9

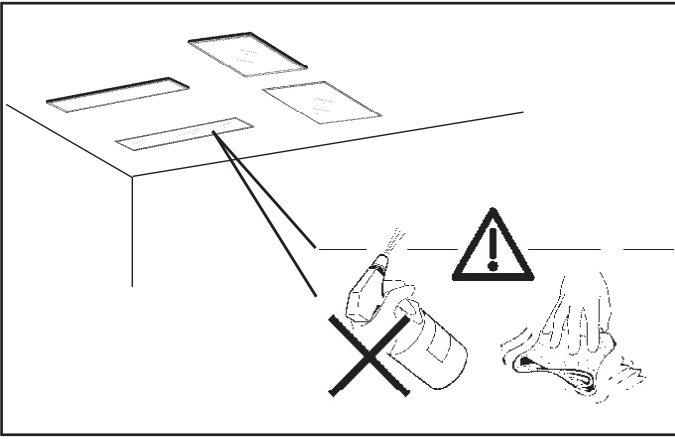

AR **تنبيه: لاستبدال الضوء LED اتصل بشركة iGuzzini .**

IT N.B.: Per la sostituzione del LED contattare l'azienda iGuzzini.

EN N.B.: For information on LED replacement please contact iGuzzini.

ES NOTA: Para sustituir el LED llame a la empresa iGuzzini.

AR **ملاحظة: ملاحظة: أثناء تركيب نظام . يجب التقيد بحرص بالنظم السائدة المتعلقة بالشبكة الكهربائية.**

IT N.B.: DURANTE L'INSTALLAZIONE DEL SISTEMA RISPETTARE SCRUPolosAMENTE LE NORME IMPIANTISTICHE VIGENTI.

EN N.B.: WHEN INSTALLING THE SYSTEM, STRICTLY COMPLY WITH ALL REGULATIONS ON INSTALLATION IN FORCE.

ES N.B.: DURANTE LA INSTALACIÓN DEL SISTEMA RESPETAR ESCRUPulosAMENTE LAS NORMAS DE INSTALACIÓN VIGENTES.

1.154.606.04 IS07206/07	iQuzini	fattore di potenza power factor facteur de puissance Leistungsfaktor vermogensfactor factor de potencia effektfaktor effektfaktor effektfaktor фактор мощности 功率因数	corrente assorbita absorbed current courant absorbé Stromaufnahme stroomopname corriente absorbida absorberet strøm absorbert strøm tillförd strøm поглощаемая мощность 电源电流 (A)
ART.			
ME68 - ME69 - N257 - N258 ME76 - ME77 - N261 - N262	0,96	0,250	
ME70 - ME71 - N259 - N260 ME78 - ME79 - N263 - N264 N249 - N250 - N251 - N252		0,220	
ME84 - ME85 - N265 - N266 ME92 - ME93 - N269 - N270	0,95	0,210	
ME86 - ME87 - N267 - N268 ME94 - ME95 - N271 - N272 N253 - N254 - N255 - N256 P172 - P173 - P174 - P175 P176 - P177	0,96	0,190	

1.154.606.04 IS07206/07	iQuzini	fattore di potenza power factor facteur de puissance Leistungsfaktor vermogensfactor factor de potencia effektfaktor effektfaktor effektfaktor фактор мощности 功率因数	corrente assorbita absorbed current courant absorbé Stromaufnahme stroomopname corriente absorbida absorberet strøm absorbert strøm tillförd strøm поглощаемая мощность 电源电流 (A)
ART.			
ME68 - ME69 - N257 - N258 ME76 - ME77 - N261 - N262	0,96	0,250	
ME70 - ME71 - N259 - N260 ME78 - ME79 - N263 - N264 N249 - N250 - N251 - N252		0,220	
ME84 - ME85 - N265 - N266 ME92 - ME93 - N269 - N270	0,95	0,210	
ME86 - ME87 - N267 - N268 ME94 - ME95 - N271 - N272 N253 - N254 - N255 - N256 P172 - P173 - P174 - P175 P176 - P177	0,96	0,190	

1.154.606.04 IS07206/07	iQuzini	fattore di potenza power factor facteur de puissance Leistungsfaktor vermogensfactor factor de potencia effektfaktor effektfaktor effektfaktor фактор мощности 功率因数	corrente assorbita absorbed current courant absorbé Stromaufnahme stroomopname corriente absorbida absorberet strøm absorbert strøm tillförd strøm поглощаемая мощность 电源电流 (A)
ART.			
ME68 - ME69 - N257 - N258 ME76 - ME77 - N261 - N262	0,96	0,250	
ME70 - ME71 - N259 - N260 ME78 - ME79 - N263 - N264 N249 - N250 - N251 - N252		0,220	
ME84 - ME85 - N265 - N266 ME92 - ME93 - N269 - N270	0,95	0,210	
ME86 - ME87 - N267 - N268 ME94 - ME95 - N271 - N272 N253 - N254 - N255 - N256 P172 - P173 - P174 - P175 P176 - P177	0,96	0,190	

1.154.606.04 IS07206/07	iQuzini	fattore di potenza power factor facteur de puissance Leistungsfaktor vermogensfactor factor de potencia effektfaktor effektfaktor effektfaktor фактор мощности 功率因数	corrente assorbita absorbed current courant absorbé Stromaufnahme stroomopname corriente absorbida absorberet strøm absorbert strøm tillförd strøm поглощаемая мощность 电源电流 (A)
ART.			
ME68 - ME69 - N257 - N258 ME76 - ME77 - N261 - N262	0,96	0,250	
ME70 - ME71 - N259 - N260 ME78 - ME79 - N263 - N264 N249 - N250 - N251 - N252		0,220	
ME84 - ME85 - N265 - N266 ME92 - ME93 - N269 - N270	0,95	0,210	
ME86 - ME87 - N267 - N268 ME94 - ME95 - N271 - N272 N253 - N254 - N255 - N256 P172 - P173 - P174 - P175 P176 - P177	0,96	0,190	

1.154.606.04 IS07206/07	iQuzini	fattore di potenza power factor facteur de puissance Leistungsfaktor vermogensfactor factor de potencia effektfaktor effektfaktor effektfaktor фактор мощности 功率因数	corrente assorbita absorbed current courant absorbé Stromaufnahme stroomopname corriente absorbida absorberet strøm absorbert strøm tillförd strøm поглощаемая мощность 电源电流 (A)
ART.			
ME68 - ME69 - N257 - N258 ME76 - ME77 - N261 - N262	0,96	0,250	
ME70 - ME71 - N259 - N260 ME78 - ME79 - N263 - N264 N249 - N250 - N251 - N252		0,220	
ME84 - ME85 - N265 - N266 ME92 - ME93 - N269 - N270	0,95	0,210	
ME86 - ME87 - N267 - N268 ME94 - ME95 - N271 - N272 N253 - N254 - N255 - N256 P172 - P173 - P174 - P175 P176 - P177	0,96	0,190	

1.154.606.04 IS07206/07	iQuzini	fattore di potenza power factor facteur de puissance Leistungsfaktor vermogensfactor factor de potencia effektfaktor effektfaktor effektfaktor фактор мощности 功率因数	corrente assorbita absorbed current courant absorbé Stromaufnahme stroomopname corriente absorbida absorberet strøm absorbert strøm tillförd strøm поглощаемая мощность 电源电流 (A)
ART.			
ME68 - ME69 - N257 - N258 ME76 - ME77 - N261 - N262	0,96	0,250	
ME70 - ME71 - N259 - N260 ME78 - ME79 - N263 - N264 N249 - N250 - N251 - N252		0,220	
ME84 - ME85 - N265 - N266 ME92 - ME93 - N269 - N270	0,95	0,210	
ME86 - ME87 - N267 - N268 ME94 - ME95 - N271 - N272 N253 - N254 - N255 - N256 P172 - P173 - P174 - P175 P176 - P177	0,96	0,190	

- I** Istruzioni per le operazioni di servizio per l'apparecchio di illuminazione
GB Instructions on luminaire service operations
F Instructions pour les opérations de service du luminaire
D Wartungsanleitung für die Leuchte
NL Instructies voor de onderhoudsoperaties op de verlichtingsarmatuur
E Instrucciones para las operaciones de servicio del aparato de alumbrado
DK Anvisninger i serviceindgreb på belysningsarmatur
N Anvisninger for betjening av lysapparatet
S Instruktioner för användning av belysningsanordningen
RUS Инструкции по эксплуатации осветительного прибора
CN 照明装置检修操作说明

Sostituire la lampada parzialmente esausta
 Replace the partly exhausted lamp
 Remplacer la lampe partiellement épuisée
 Die teilweise erschöpfte Lampe austauschen
 Vervang de gedeeltelijk lege lamp
 Sustituir la lámpara parzialmente agotada
 Udskift den delvist udtjente pære
 Skifte ut den delvis utbrente lyspæren
 Byt ut den delvis förbrukade lampan
 Замена частично отработанной лампочки
 更换部分老化的灯泡



Spegnimento
 Switch it off
 Extinction
 Ausschaltung
 Uitschakeling
 Apagado
 Slukning
 Slukking
 Släckning
 Выключение
 关灯

Interrompere l'alimentazione dell'apparecchio
 Cut the power supply to the luminaire
 Couper l'alimentation du luminaire
 Stromversorgung der Leuchte unterbrechen
 Onderbreek de voeding van het apparaat
 Interrumpir la alimentación del aparato
 Afbryd armaturets strømforsyning
 Avbryte strømtilførselen til apparatet
 Koppla från anordningens strömförsörjning
 Отключить электропитание прибора
 中断装置供电



Aprire l'apparecchio
 Open the fixture
 Ouvrir le luminaire
 Das Gerät öffnen
 Open het apparaat
 Abrir el aparato
 Åbn armaturet
 Åpne apparatet
 Öppna anordningen
 Раскрыть прибор
 打开装置



Rimuovere la lampada esausta
 Remove the exhausted lamp
 Retirer la lampe épuisée
 Die alte Lampe entnehmen
 Verwijder de lege lamp
 Quitar la lámpara agotada
 Tag den udtjente pære ud
 Fjerne den utbrente lyspæren
 Ta bort den förbrukade lampan
 Вынуть старую лампочку
 取出老化的灯泡

Portarla in un centro di riciclaggio
 Carry it to a recycling centre
 La porter dans une déchetterie pour son recyclage
 Ordnungsgemäß entsorgen
 Breng de lamp naar een recyclingcentrum
 Llevarla a un centro de reciclaje
 Aflever den på en genbrugsstation
 Lever den til en miljøstasjon
 Lämna in den till en återvinningsanläggning
 Сдать ее в пункт приема утильсырья
 将其送往回收中心



Inserire la nuova lampada
 Introduce the new lamp
 Installer la lampe neuve
 Die neue Lampe einsetzen
 Doe de nieuwe lamp op zijn plek
 Montar la nueva lámpara
 Sæt den nye pære i
 Sette i den nye pæren
 Sätt i den nya lampan
 Вставить новую лампочку
 装入新灯泡

Inserire la nuova lampada nel portalampana
 Fit the new lamp into the socket
 Installer la nouvelle lampe dans le support de lampe
 Die neue Lampe in den Sockel einsetzen
 Doe de nieuwe lamp in de lamphouder
 Montar la nueva lámpara en el portalampana
 Sæt den nye pære i fatningen
 Sette den nye pæren inn i lampeholderen
 Sätt i den nya lampan i lamphållaren
 Вставить новую лампочку в патрон
 将新灯泡插入灯泡架中



Riposizionare ottica
 Re-place the optic
 Remettre l'optique à sa place
 Die Optik wieder einsetzen
 Doe de optiek weer op zijn plaats
 Volver a montar la óptica
 Sæt den optiske enhed på plads
 Innstille linsen
 Flytta om optiken
 Отрегулировать линзы
 重新定位光头



Effettuare prova di funzionamento
 Perform operative test
 Procéder à un essai de fonctionnement
 Eine Funktionsprüfung durchführen
 Controleer de correcte werking
 Hacer una prueba de funcionamiento
 Afprøv funktionen
 Prøve om den fungerer
 Utför funktionstest
 Выполнить проверку исправности работы
 执行功能测试



I Istruzioni per la pulizia dell'apparecchio di illuminazione
GB Instructions on luminaire cleaning operations
F Instructions pour le nettoyage du luminaire
D Anweisungen zur Reinigung der Leuchte
NL Instructies voor de reiniging van de verlichtingsarmatuur
E Instrucciones para limpiar el aparato de alumbrado
DK Anvisninger i rengøring af belysningsarmaturet
N Anvisninger for rengjøring av lysapparatet
S Instruktioner för rengöring av belysningsanordningen
RUS Инструкции по чистке осветительного прибора
CN 照明装置清洁说明

Pulire l'apparecchio
 Clean the fixture
Nettoyer le luminaire
 Das Gerät reinigen
Reinig het apparaat
 Limpiar el aparato
Rengør armaturet
Rengjøre apparatet
Rengör anordningen
 Чистка прибора
 清洁装置



Spegnimento
 Switch it off
Extinction
Ausschaltung
Uitschakeling
Apagado
Slukning
Slukking
Släckning
Выключение
 关灯

Interrompere l'alimentazione dell'apparecchio
 Cut the power supply to the luminaire
 Couper l'alimentation du luminaire
 Stromversorgung der Leuchte unterbrechen
 Onderbreek de voeding van het apparaat
 Interrumpir la alimentación del aparato
 Afbryd armaturets strømforsyning
 Avbryt strømtilførselen til apparatet
 Koppla från anordningens strömförsörjning
 Отключить электропитание прибора
 中断装置供电



Spolverare l'ottica esterna
 Remove dust from the external optic
Dépoussiérer l'optique extérieure
Die externe Optik abstauben
Stof de externe optiek af
Quitar el polvo de la óptica exterior
Tør støvet af den udvendige optiske enhed
Fjerne støv fra den eksterne lysenheten
Damma av den yttre optiken
Вытереть пыль с внешней стороны линз
 为外侧光头掸尘



Lavare l'ottica esterna
 Wash the external optic
Laver l'optique extérieure
Die externe Optik waschen
Was de externe optiek
Lavar la óptica exterior
Vask den udvendige optiske enhed
Vaske den eksterne lysenheten
Rengör den yttre optiken
Вымыть линзы с внешней стороны
 清洁外光头



Rimuovere l'ottica
 Remove the optic
Retirer l'optique
Die Optik abnehmen
Verwijder de optiek
Quitar la óptica
Tag den optiske enhed af
Fjerne lysenheten
Ta bort optiken
Снять линзы
 取下光头



Pulire la parte interna dell'apparecchio di illuminazione
 Clean the inside of the fixture
Nettoyer l'intérieur du luminaire
Die Innenseite der Leuchte reinigen
Reinig de binnenzijde van de verlichtingsarmatuur
Limpiar el interior del aparato de alumbrado
Rengør belysningsarmaturets indvendige dele
Rengjøre lysapparatet innvendig
Rengör belysningsanordningen invändigt
Протереть осветительный прибор изнутри
 清洁照明装置内部



Riposizionare ottica
 Re-place the optic
Remettre l'optique à sa place
Die Optik wieder einsetzen
Doe de optiek weer op zijn plaats
Volver a montar la óptica
Sæt den optiske enhed på plads
Innstille linsen
Flytta om optiken
Отрегулировать линзы
 重新定位光头



Effettuare prova di funzionamento
 Perform operative test
Procéder à un essai de fonctionnement
Eine Funktionsprüfung durchführen
Controleer de correcte werking
Hacer una prueba de funcionamiento
Afprøv funktionen
Prøve om den fungerer
Utför funktionstest
Выполнить проверку исправности работы
 执行功能测试

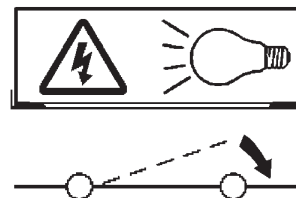

- I** Istruzioni per il fine vita e lo smaltimento dei componenti
GB Instructions on end-of-life and component disposal
F Instructions pour la gestion des composants en fin de vie et leur mise au rebut
D Anweisungen zur Entsorgung der Leuchtenkomponenten
NL Instructies voor het verwijderen van de armatuur en het recyclen van de onderdelen
E Instrucciones para el final de vida y la eliminación los componentes
DK Anvisninger i udtjent armatur og bortskaffelse af komponenter
N Anvisninger for endt levetid og avfallsbehandling av delene
S Instruktioner vid bortskaffning och kassering av komponenter
RUS Инструкции по утилизации прибора и его комплектующих по окончании его срока службы
CN 寿命期结束与零件废弃处置说明

<p>Spegnimento Switch it off Extinction Ausschaltung Uitschakeling Apagado Slukning Slukking Släckning Выключение 关灯</p> <p>Interrompere l'alimentazione dell'apparecchio Cut the power supply to the luminaire Couper l'alimentation du luminaire Stromversorgung der Leuchte unterbrechen Onderbreek de voeding van het apparaat Interrompirla alimentación del aparato Afbryd armaturets strømforsyning Avbryt strømtilførselen til apparatet Koppla från anordningens strömförsörjning Отключить электропитание прибора 中断装置供电</p> 	<p>Rimuovere la/e lampada/e per la dismissione Remove the lamp(s) for decommissioning Retirer la(les) lampe(s) pour sa(leur) mise au rebut Die Lampe/n ordnungsgemäß entsorgen Verwijder de lamp(en) voor het recyclen Quitar la(s) lámpara(s) para el desecho Tag pæren/pærerne ud til bortskaffelse Fjerne lampen/-e som skal kastes Ta bort lampan/-orna för bortskaffningen Вынуть лампочку/и для утилизации прибора 取出需要丢弃的灯泡</p> 	<p>Rimuovere la batteria per la dismissione Remove the battery for decommissioning Retirer la batterie pour sa mise au rebut Die Batterie ordnungsgemäß entsorgen Verwijder de batterij voor het recyclen Quitar la batería para el desecho Tag batteriet ud til bortskaffelse Fjerne batteriet som skal kastes Ta bort batteriet för bortskaffningen Вынуть батарейку для утилизации прибора 取出需要丢弃的电池</p> 	<p>Rimuovere l'apparecchio per la dismissione Remove the fixture for decommissioning Enlever le luminaire pour sa mise au rebut Das Gerät ordnungsgemäß entsorgen Verwijder het apparaat voor het recyclen Quitar el aparato para el desecho Tag armaturet ud til bortskaffelse Fjerne apparatet som skal kastes Ta bort anordningen för bortskaffningen Снять прибор для утилизации 取出需要丢弃的装置</p> 
---	--	--	--

<p>Inviare i materiali ad un centro di raccolta RAEE Send the materials to a WEEE collection centre Envoyer les matériaux dans une déchetterie DEEE Die Materialien in einem WEEE-Zentrum entsorgen Zend de materialen naar een recyclingscentrum voor de AEEA Enviar los materiales a un centro de recogida RAEE Afløver materialerne på et indsamlingscenter for elektronisk udstyr Sende materialene til en miljøstasjon for resirkulering av EE-avfall Skicka materialet till en RAEE uppsamlingscentral Сдать материалы в пункт приема утильсырья 将材料送往电气和电子垃圾回收中心</p> 			
--	--	--	--