

## LEDSTRIP (underscore)

### ATTENZIONE:

LA SICUREZZA DELL'APPARECCHIO E' GARANTITA SOLO CON L'USO APPROPRIATO DELLE SEGUENTI ISTRUZIONI; PERTANTO E' NECESSARIO CONSERVARLE.

### WARNING:

THE SAFETY OF THIS FIXTURE IS GUARANTEED ONLY IF YOU COMPLY WITH THESE INSTRUCTIONS; REMEMBER TO CONSERVE IN A SAFE PLACE.

### ATTENTION:

LA SECURITE DE L'APPAREIL N'EST GARANTIE QU'EN CAS D'UTILISATION CORRECTE DES INSTRUCTIONS SUIVANTES; IL FAUT PAR CONSEQUENT LES CONSERVER.

### ACHTUNG:

DIE SICHERHEIT DES GERÄTES WIRD NUR DURCH SACHGEMÄSSE BEFOLGUNG NACHSTEHENDER ANWEISUNGEN GEWÄHRLEISTET; IHRE AUFBEWAHRUNG IST DESHALB SEHR WICHTIG.

### OPGELET:

DE VEILIGHEID VAN DI ATOESTEL IS SLECHTS DAN GEGARANDEERD ALS INDIEN DE VOLGENDE INSTRUCTIES STRIKT WORDEN TOEGEPAST; DAAROM MOET MEN ZE OOK BEWAAREN.

### ATENCIÓN:

LA SEGURIDAD DEL APARATO SE GARANTIZA SOLO CUMPLIENDO CUIDADOSAMENTE LAS SIGUIENTES INSTRUCCIONES; POR ELLO, ES NECESARIO CONSERVARLAS.

### BEMÆRK:

SIKKERHEDEN VED BRUG AF ARMATURET KAN KUN GARANTERES, HVIS DISSE ANVISNINGER FØLGES; SØRG DERFOR FOR AT GEMME DEM.

### ADVARSEL:

SIKKERHETEN TIL DETTE APPARATET GARANTERES KUN HVIS DU OVERHOLDER DISSE INSTRUKSJONENE; HUSK Å OPPBEVARE DEM PÅ ET TRYGT STED.

### OBSERVERA!

UTRUSTNINGENS SÄKERHET KAN ENDAST GARANTERAS OM DESSA ANVISNINGAR RESPEKTERAS I DETALJ. SPARA DÄRFÖR DESSA ANVISNINGAR FÖR FRAMTIDA KONSULTATION.

### ВНИМАНИЕ:

МЫ ГАРАНТИРУЕМ БЕЗОПАСНУЮ ЭКСПЛУАТАЦИЮ ИЗДЕЛИЯ ТОЛЬКО ПРИ СОБЛЮДЕНИИ СЛЕДУЮЩИХ ИНСТРУКЦИЙ; С ЭТОЙ ЦЕЛЬЮ НЕОБХОДИМО СОХРАНИТЬ ДАННУЮ БРОШЮРУ.

### 警告:

为确保该装置安全，请遵守操作指示；并于安全场所放置。

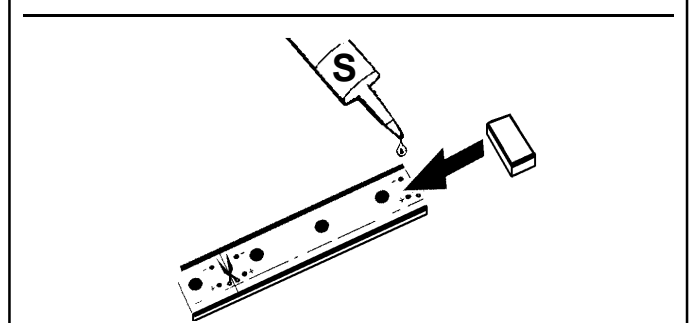
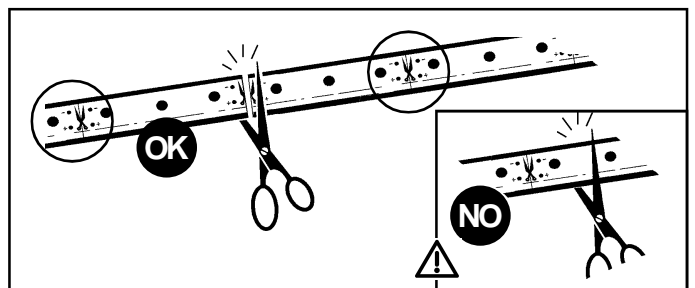
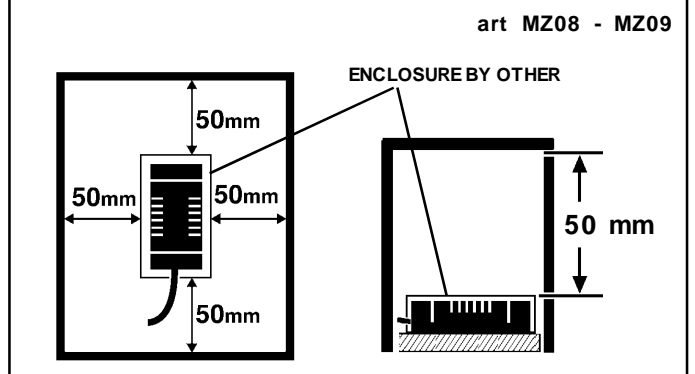
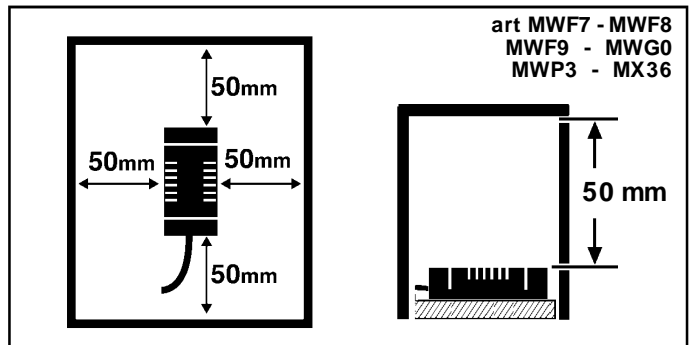
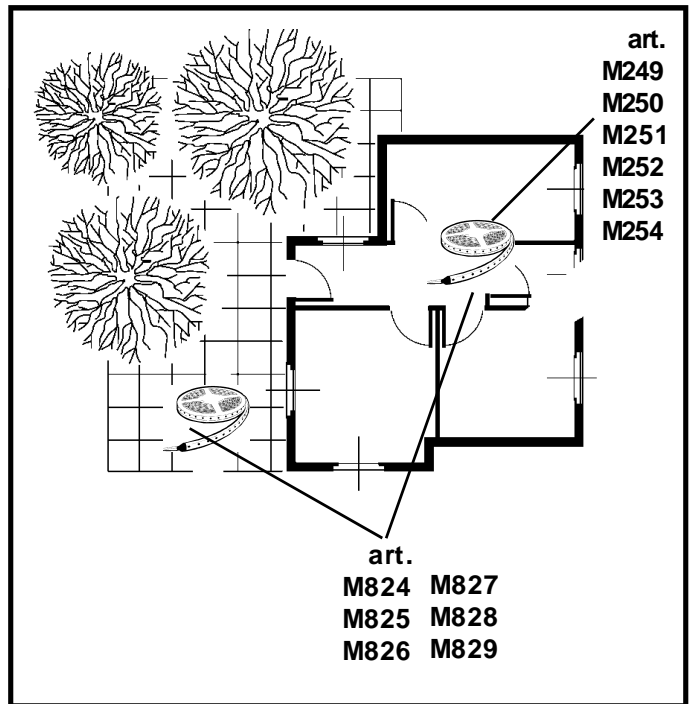
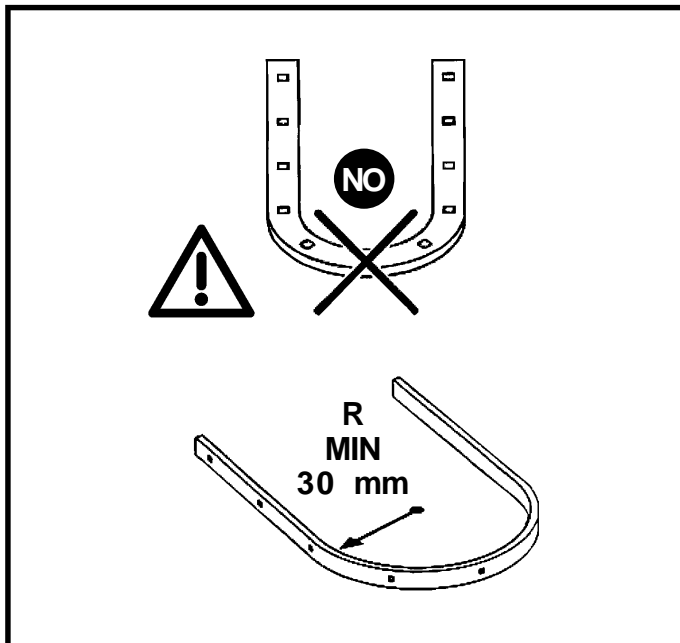
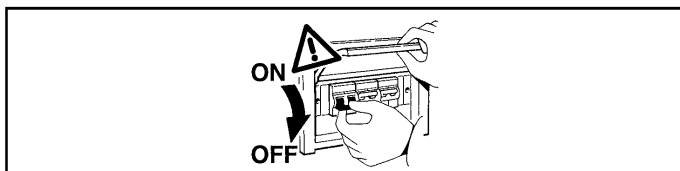

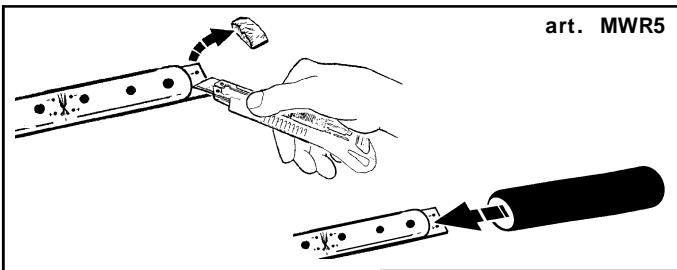

art. MWR5

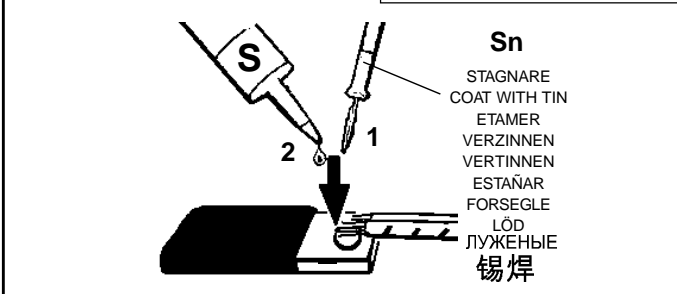
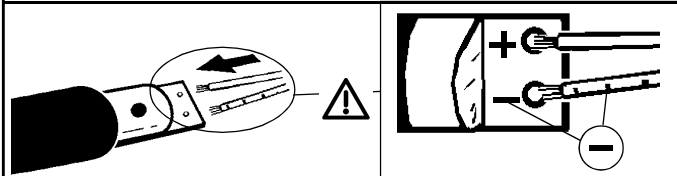

Sn

STAGNARE  
COAT WITH TIN  
ETAMER  
VERZINNEN  
VERTINNEN  
ESTAÑAR  
FORSEGLE  
LÖD  
ЛУЖЕНЫЕ  
锡焊

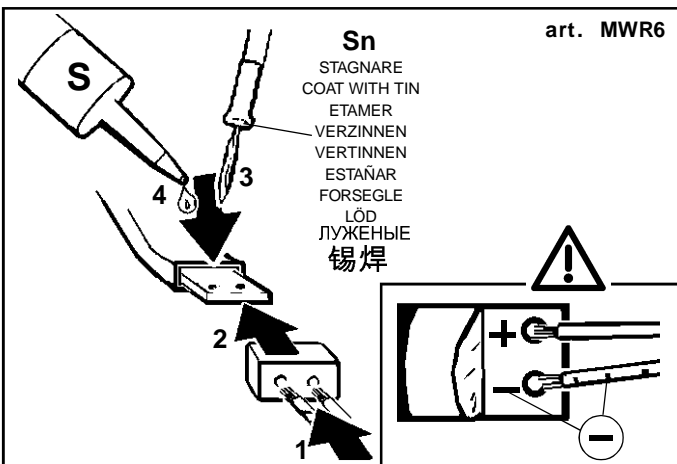
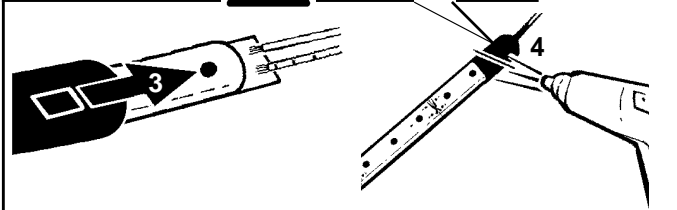
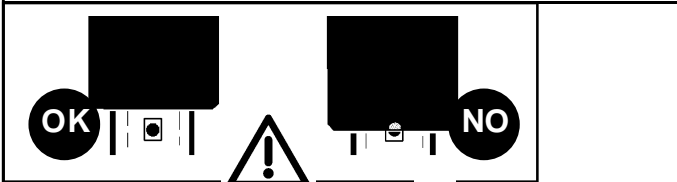

art. MWR6

Sn  
STAGNARE  
COAT WITH TIN  
ETAMER  
VERZINNEN  
VERTINNEN  
ESTAÑAR  
FORSEGLE  
LÖD  
ЛУЖЕНЫЕ  
锡焊

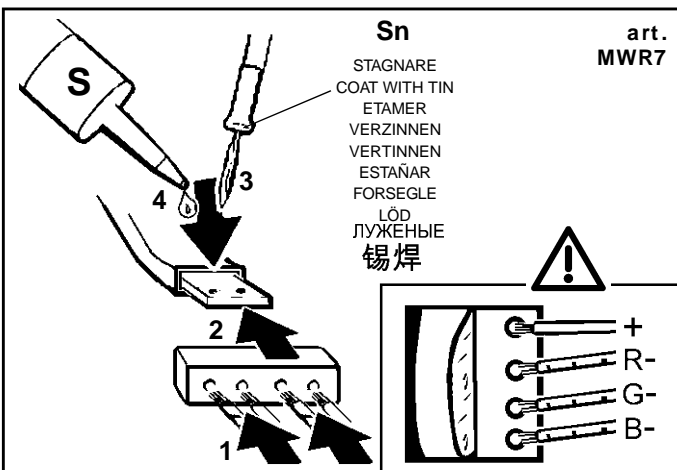

art. MWR7

Sn  
STAGNARE  
COAT WITH TIN  
ETAMER  
VERZINNEN  
VERTINNEN  
ESTAÑAR  
FORSEGLE  
LÖD  
ЛУЖЕНЫЕ  
锡焊

**I N.B.:** Il grado di protezione del sistema, è garantito soltanto se si effettua correttamente l'operazione di siliconatura **S.**

**GB N.B.:** The degree of protection offered by the system is only guaranteed if the siliconisation procedure is performed correctly **S.**

**F N.B.:** L'indice de protection du système n'est assuré que si l'application de silicone a été effectuée correctement **S.**

**D N.B.:** Der Schutzgrad des Systems ist nur gewährleistet, wenn die Silikonabdichtung korrekt ausgeführt wird **S.**

**NL N.B.:** De beschermingsgraad van het systeem is alleen dan gegarandeerd als het silicone goed is aangebracht **S.**

**E N.B.:** El grado de protección del sistema está garantizado sólo si se realiza correctamente la operación de siliconado **S.**

**DK N.B.:** Beskyttelsesgraden på systemet kan kun garanteres hvis der påføres silikone på korrekt vis **S.**

**N N.B.:** Graden av beskyttelse som tilbys av systemet garanteres kun hvis silikonprosedyren utføres riktig **S.**

**S OBS!** Systemets skyddsgrad garanteras endast om silikoniseringsproceduren utförs på ett korrekt sätt **S.**

**RUS ПРИМЕЧАНИЕ:** Класс электробезопасности системы гарантируется, только если будет правильно выполнена пропитка силиконом **S.**

**CN 注意事项:** 只有在正确地施行了聚硅酮操作之后系统保护的等级才被保证。**S.**

MAX m								
ALIMENTATORE - BALLAST - BALLAST - VORSCHALTGERÄT VOORSCHAKELAPPARAAT - ALIMENTADOR - STRØMFORSYNINGSENHED BALLAST - STRÖMFÖRSÖRJNINGSANORDNING БЛОК ПИТАНИЯ - 电源								
ART	MWF7 MZ08	MX36 MWF8 MZ09	MWF9	MWG0	MWF7 MZ08 + MWF9	MWF8 MZ09 + MWF9	MWF7 MZ08 + MWP3	MWF8 MZ09 + MWP3
M249-M250 M251-M252 M254-M824 M825-M826 M827-M828	5	10*	/	/	/	/	5	10
M253 - M829	/	/	10	10	5	10	/	/

**I** E' possibile collegare in serie fino a 10m di Led Strip accettando delle differenze di luminosità sulla linea

**GB** The in-series connection of LED strips is possible up to 10 m allowing for any differences in luminosity on the line.

**F** Il est possible de brancher en série jusqu'à 10 mètres de "Led Strip" sous réserve d'accepter des différences de luminosité sur la ligne.

**D** Es können bis zu 10m "LED Strip" in Serie geschaltet werden, wobei jedoch unterschiedliche Helligkeiten entlang der Linie entstehen.

**NL** Het is mogelijk tot aan 10 m "Led Strips" op dezelfde serie aan te sluiten als u verschillen van lichtintensiteit op de lijn kunt accepteren.

**E** Se puede conectar en serie hasta 10m de "Led Strip" aceptando diferencias de luminosidad en la línea.

**DK** Man kan serieforbinde op til 10 m "Led Strip", hvilket vil medføre forskelle i lysstyrken på linjen.

**N** Det er mulig å koble opptil 10 m "Led Strip" i serie ved å godta lysforskjeller på linjen.

**S** Det går att serieansluta upp till 10 m "Led Strip" genom att acceptera ljusskillnaderna på linjen.

**RUS** Можно последовательно подсоединить вплоть до 10m "Led Strip", допуская разницу в освещении на линии.

**CN** LED 灯条串联连接可达 10 米, 并且线路上灯可以呈现不同的亮度。

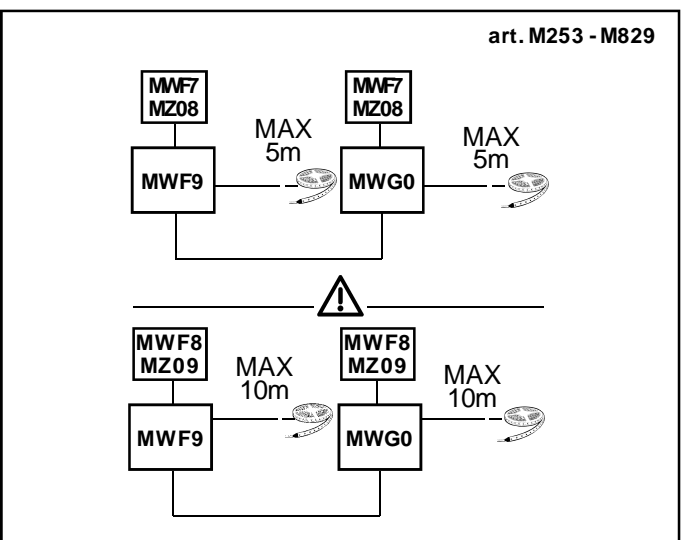

art. M253 - M829

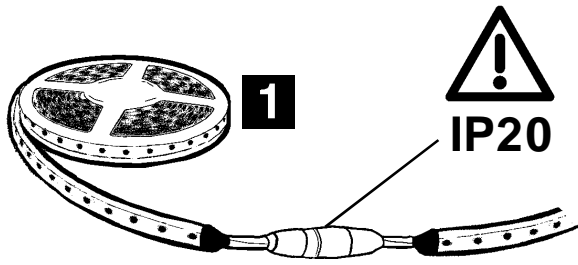

NASTRO AUTOAGGLOMERANTE  
 SELF-VULCANISING TAPE  
 RUBAN AUTO-SOUDABLE  
 SELBSTHAFTBAND - (Klebefilm SCOTCH 23 3M)  
 ZELFFUSERENDE TAPE  
 CINTA AUTOAGLOMERANTE  
 (SCOTCH 23 3M)

ART	Ampere/m [A]
M249 - M250 M251 - M252 M254 - M824 M825 - M826 M827 - M828	0.45
M253 - M829	0.4*

- \* Se utilizzato con interfaccia MWF9 - MWG0
- \* If used with MWF9 - MWG0 interface
- \* En cas d'utilisation avec l'interface MWF9 - MWG0
- \* Wenn mit Schnittstelle MWF9 - MWG0 verwendet
- \* Indien gebruikt met een interface MWF9 - MWG0
- \* Si utilizado con interfaz MWF9 - MWG0
- \* Hvis anvendt med grænseflade MWF9 - MWG0
- \* Hvis brukt med grensesnitt MWF9 - MWG0
- \* Om den används med gränssnitt MWF9 - MWG0
- \* Если используется интерфейс MWF9 - MWG0
- \* 如使用 MWF9 - MWG0 接口

$$L = \frac{25 \times S}{A \times m}$$

S = Sezione cavo in Rame [mm <sup>2</sup>]  
 A = Ampere/m  
 m = Metri totali collegati alla Linea

S = Copper cable section [mm <sup>2</sup>]  
 A = Ampere/m  
 m = Total metres connected to the line

S = Section du câble en cuivre [mm <sup>2</sup>]  
 A = Ampères/m  
 m = Total des mètres raccordés à la ligne

S = Durchmesser Kupferkabel [mm <sup>2</sup>]  
 A = Ampere/m  
 m = Summe der an die Linie angeschlossenen Meter

S = Sectie koperen kabel [mm <sup>2</sup>]  
 A = Ampère/m  
 m = totaal aangesloten Meters op de Lijn

S = Sección cable de cobre [mm <sup>2</sup>]  
 A = Ampere/m  
 m = Metros totales conectados a la línea

S = Tværsnit kobberkabel [mm <sup>2</sup>]  
 A = Ampere/m  
 m = Meter i alt tilsluttet linjen

S = Kabletverrsnitt i kobber [mm <sup>2</sup>]  
 A = Ampere/m  
 m = Meter totalt tilkoblet til linjen

S = Kopparkabelns tvärsnitt [mm <sup>2</sup>]  
 A = Ampere/m  
 m = Totalt antal meter anslutna till linjen

S = Сечение медного провода [мм <sup>2</sup>]  
 A = Ампер/м  
 m = Всего метров, подсоединенных к Линии

S = 铜电缆截面 [平方毫米]

A = 安培/米

m = 连接到线路上的总长度 (按米计算)

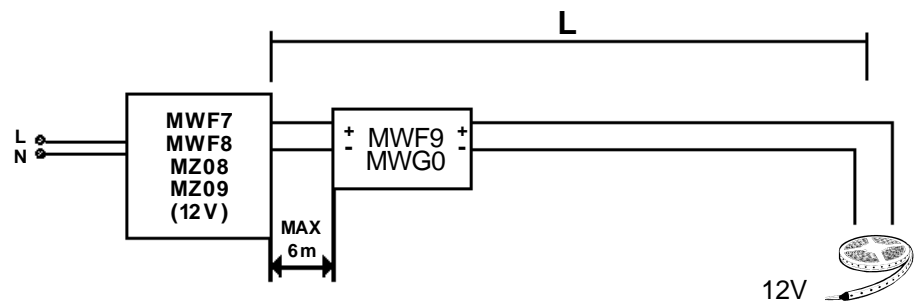
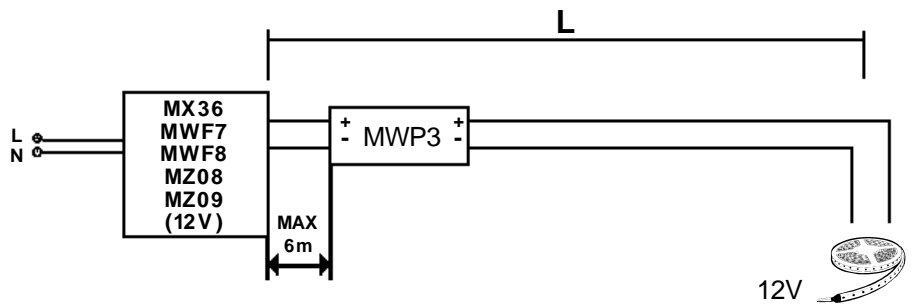
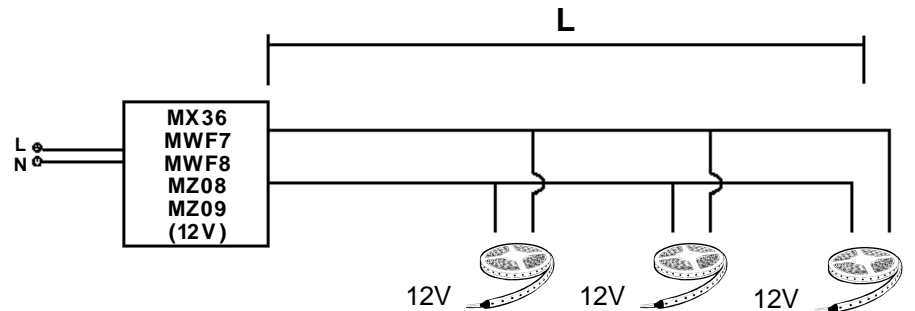
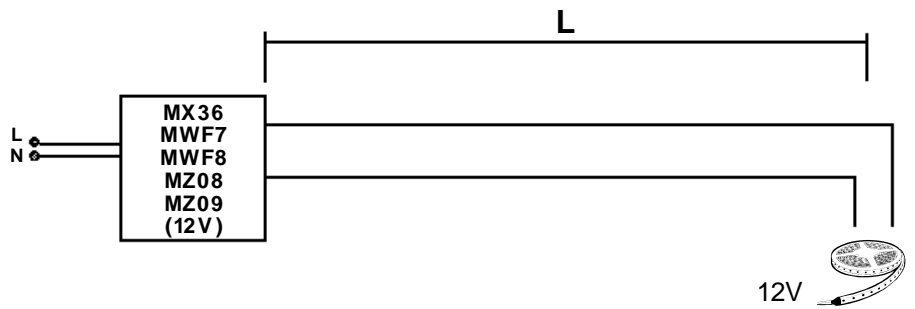

art. MWF7 - MWF8 - MWP3  
MZ08 - MZ09

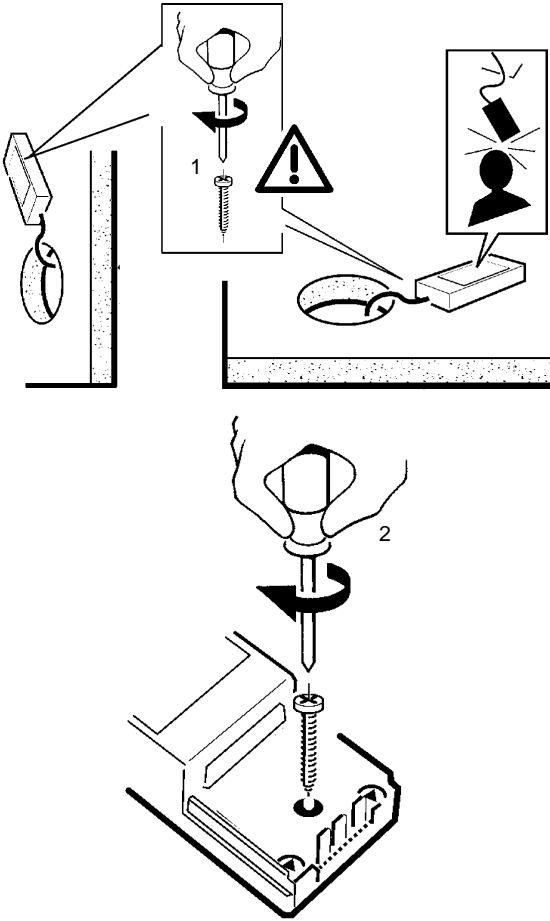

art MWF9 - MWG0

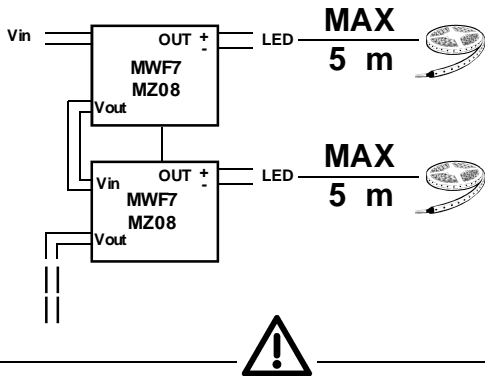
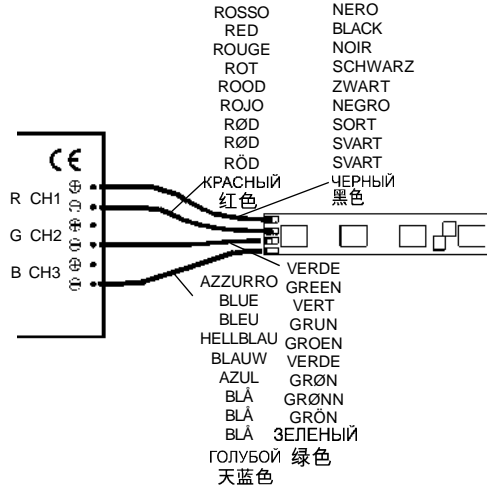

DALI

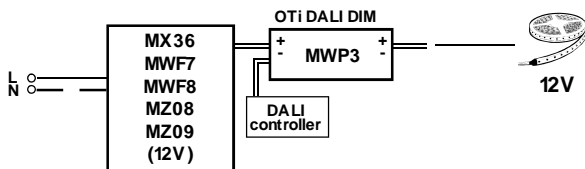

TOUCH DIM

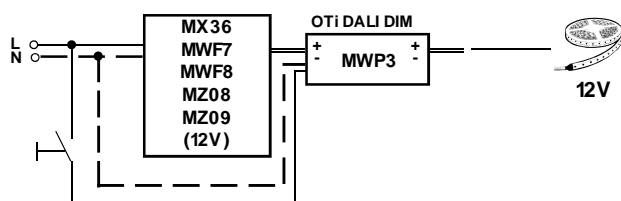

I Le prestazioni e la sicurezza dell'apparecchio sono garantite soltanto per oscillazioni della corrente del  $\pm 5\%$  rispetto al valore nominale.

La conformità alla norma è garantita soltanto utilizzando alimentatori iGuzzini (art.: MWF7/MWF8/MZ08/MZ09) od equivalenti di tipo SELV che rispondano alle vigenti norme C.E.I.

GB The performance level and safety of the lighting fixture are only guaranteed for oscillations of  $\pm 5\%$  in the current, in relation to the nominal value.

Conformity with the standard is guaranteed only if either iGuzzini ballasts (item code MWF7/MWF8/MZ08/MZ09) or equivalent SELV type ballasts which comply with current C.E.I. regulations are used.

F Les performances et la sécurité de l'appareil ne sont assurées que pour des oscillations de courant de  $\pm 5\%$  par rapport à la valeur nominale.

La conformité à la norme n'est assurée qu'en cas d'utilisation de ballasts iGuzzini (réf.: MWF7/MWF8/MZ08/MZ09) ou équivalents type SELV conformes aux normes C.E.I.

D Die Leistungen und die Sicherheit des Geräts sind nur für vom Vorschaltgerät abgehende Spannungsschwankungen von  $\pm 5\%$  in Bezug auf den Nennwert gewährleistet.

Die Übereinstimmung mit den Vorschriften ist nur bei Verwendung von iGuzzini-Netzteilen (Art.: MWF7/MWF8/MZ08/MZ09) oder gleichwertigen des Typs SELV, die den gültigen CEI-Bestimmungen entsprechen, gewährleistet.

NL De prestaties en de veiligheid van het apparaat zijn alleen gegarandeerd voor spanningsvariaties van  $\pm 5\%$  ten opzichte van de nominale waarde.

De conformiteit aan de norm wordt alleen gegarandeerd als u iGuzzini voorschakelapparaten gebruikt (art.: MWF7/MWF8/MZ08/MZ09) of overeenkomstige, van het type SELV, die aan de geldende C.E.I. normen voldoen.

E Las prestaciones y la seguridad del aparato están garantizada solamente con oscilaciones de la corriente del  $\pm 5\%$  respecto al valor nominal.

La conformidad a la norma se garantiza solamente con el uso de alimentadores iGuzzini (art. MWF7/MWF8/MZ08/MZ09) o equivalentes de tipo SELV que cumplen las normas vigentes C.E.I.

DK Armaturets ydelse og sikkerhed kan kun garanteres ved strømudsving på  $\pm 5\%$  i forhold til den nominelle værdi.

Opfyldelse af reglerne garanteres kun ved brug af strømforsyningsenheder fra iGuzzini (art.: MWF7/MWF8/MZ08/MZ09) eller tilsvarende af typen SELV, der opfylder kravene i C.E.I.-standarderne.

N Ytelsesnivået og sikkerheten til lysarmaturen kan kun garanteres for svingninger på  $\pm 5\%$  i strømmen, i forhold til nominell verdi.

Samsvar med forskriften garanteres bare ved bruk av transformatorer fra iGuzzini (art.: MWF7/MWF8/MZ08/MZ09) eller tilsvarende av typen SELV som tilsvarer gjeldende forskrifter C.E.I.

S Utrustningens prestanda och säkerhet garanteras endast vid en strömoscillation på  $\pm 5\%$  i förhållande till nominellt värde.

Överensstämmelse med standard garanteras endast genom att använda nätaggregat av typ iGuzzini (art.: MWF7/MWF8/MZ08/MZ09) eller motsvarande av typ SELV som överensstämmer med gällande C.E.I.-standard.

RUS Соответствие нормативу гарантируется только при использовании блоков питания iGuzzini (арт.: MWF7/MWF8/MZ08/MZ09) или аналогичных типа SELV, отвечающих действующим нормативам ЕЭС.

CN 只有在使用iGuzzini的供电器( MWF7/MWF8/MZ08/MZ09 产品)或者与之相同的SELV 种类的符合C.E.I. 法规的 供电器情况下, 产品的合格性才能够被保证。

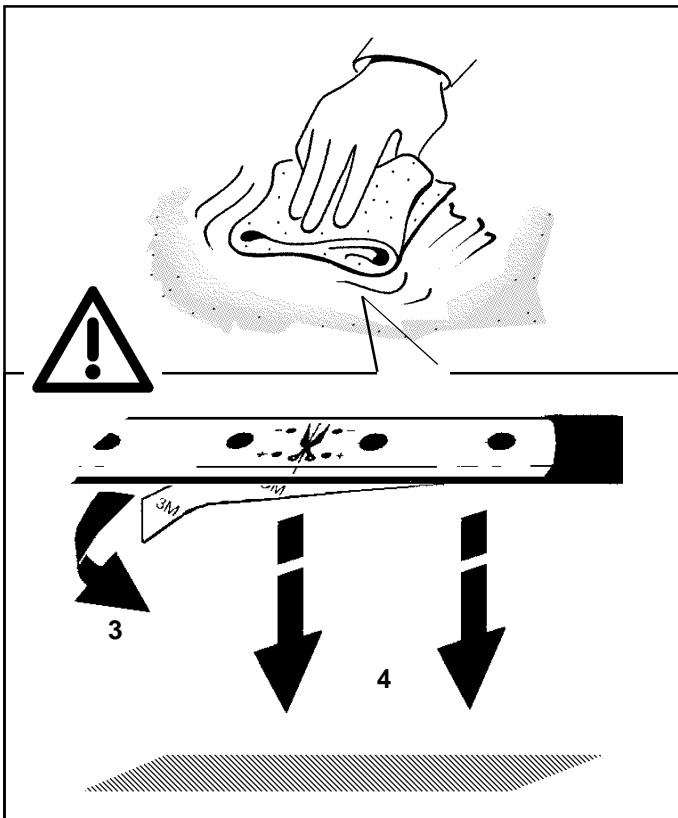

INSTALLAZIONE DEGLI ACCESSORI  
 INSTALLING THE ACCESSORIES  
 INSTALLATION DES ACCESSOIRES  
 INSTALLATION DER ZUBEHÖRTEILE  
 HET INSTALLEREN VAN DE ACCESSOIRES  
 INSTALACION DE ACCESORIOS  
 INSTALLATION AF TILBEHØR  
 INSTALLERING AV TILBEHØR  
 INSTALLATION AV TILLBEHÖR  
 МОНТАЖ ВСПОМОГАТЕЛЬНЫХ КОМПЛЕКТУЮЩИХ  
 附件的安装

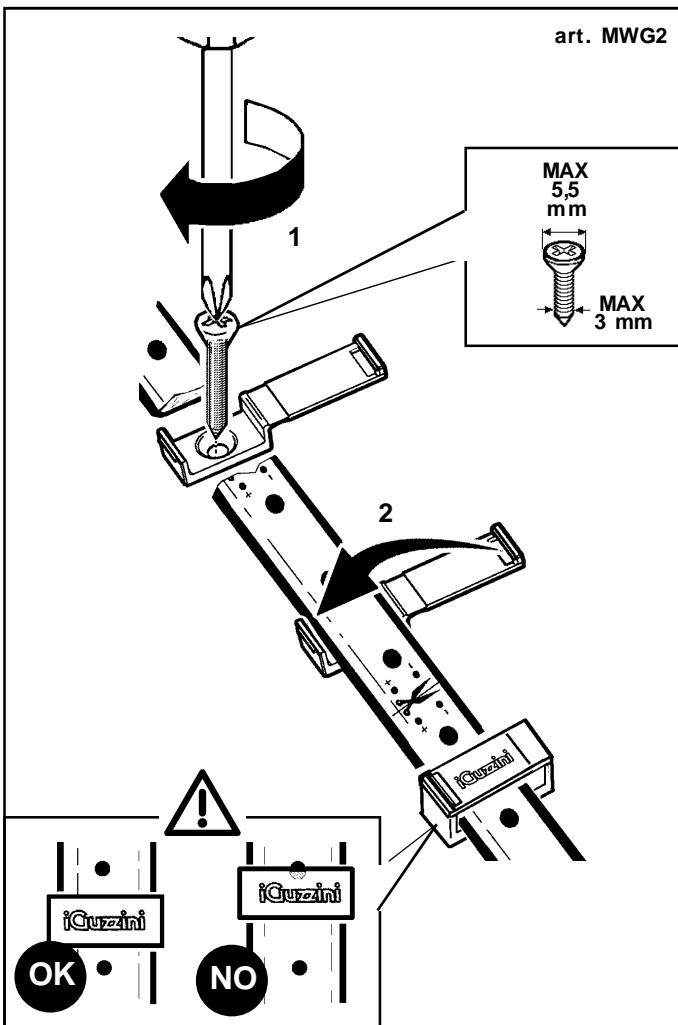

art. MWG2

MAX  
5,5  
mm  
 MAX  
3 mm

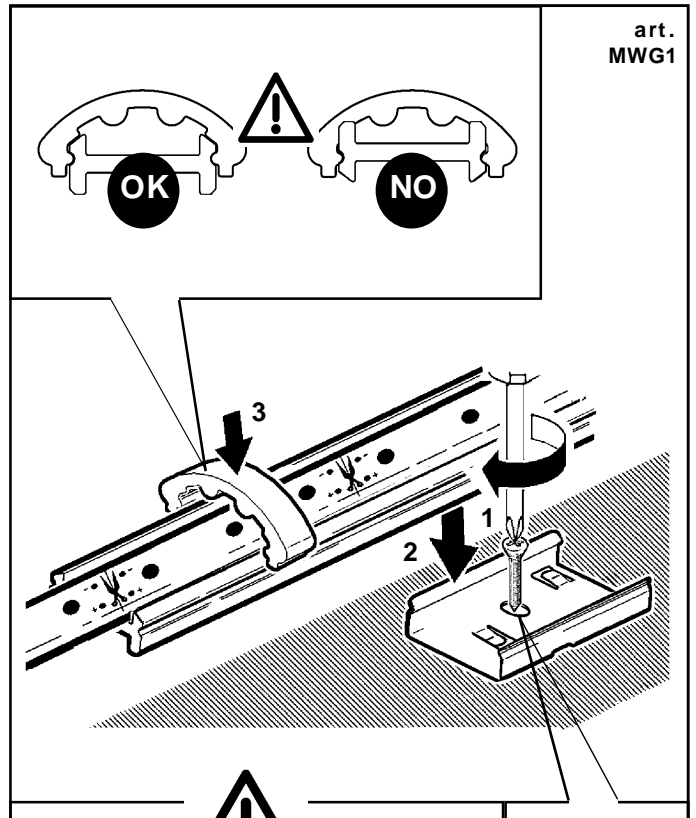

art.  
MWG1

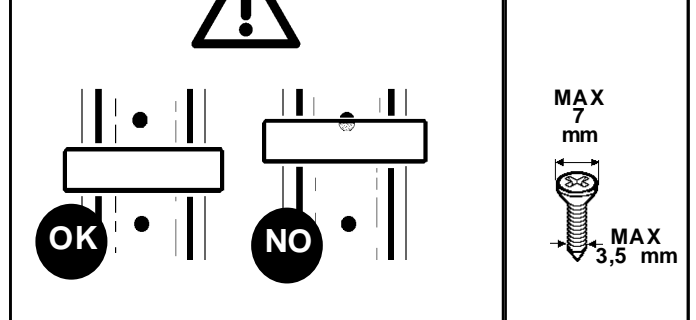

MAX  
7  
mm  
 MAX  
3,5 mm

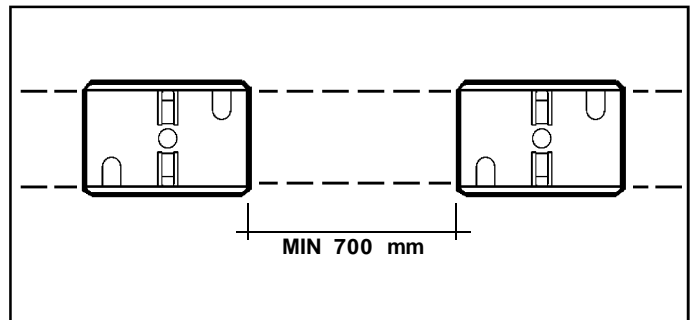

MIN 700 mm

SOSTITUZIONE DEL LED  
 REPLACING THE LED  
 REMPLACEMENT DE LA LED  
 AUSTAUSCHEN DER LED  
 VERVANGEN VAN DE LED  
 REEMPLAZO DEL LED  
 UDSKIFTNING AF LYSDIODE  
 BYTE AV LYSDIOD  
 UTSKIFTNING AV DEN LYSEMITTERENDE DIODEN  
 ЗАМЕНА СИД  
 发光二极管替换

I N.B.: Per la sostituzione del LED contattare l'azienda iGuzzini.  
 GB N.B.: For information on LED replacement please contact iGuzzini.  
 F N.B.: Pour procéder au remplacement de la LED, adressez-vous à la société iGuzzini.  
 D N.B.: Bezüglich des Austausches der LED kontaktieren Sie bitte die Firma iGuzzini.  
 N.B.: Voor het vervangen van de LED neemt u contact op met het bedrijf iGuzzini.  
 NL NOTA: Para sustituir el LED llame a la empresa iGuzzini.  
 DK N.B.: For utskifting av den lysemitterende dioden ta kontakt med firmaet iGuzzini.  
 N N.B.: For udskiftning af lysdioden, skal man kontakte iGuzzini.  
 S OBS! För byte av lysdioden, kontakta företaget iGuzzini.  
 RUS ПРИМЕЧАНИЕ: Для замены СИДов обращайтесь в компанию iGuzzini.  
 CN 注意: 有关发光二极管照明替换信息,请联系 iGuzzini 公司。

ACCESSORI PROFILI  
 PROFILES ACCESSORIES  
 ACCESSOIRES PROFILS  
 ZUBEHOER PROFILE  
 PROFIEL ONDERDELEN  
 ACCESORIOS PERFILES  
 TILBEHØR PROFILER  
 TILBEHØR PROFILER  
 ACCESSOARER PROFILER  
 Аксессуары профилей  
 配件配置文件

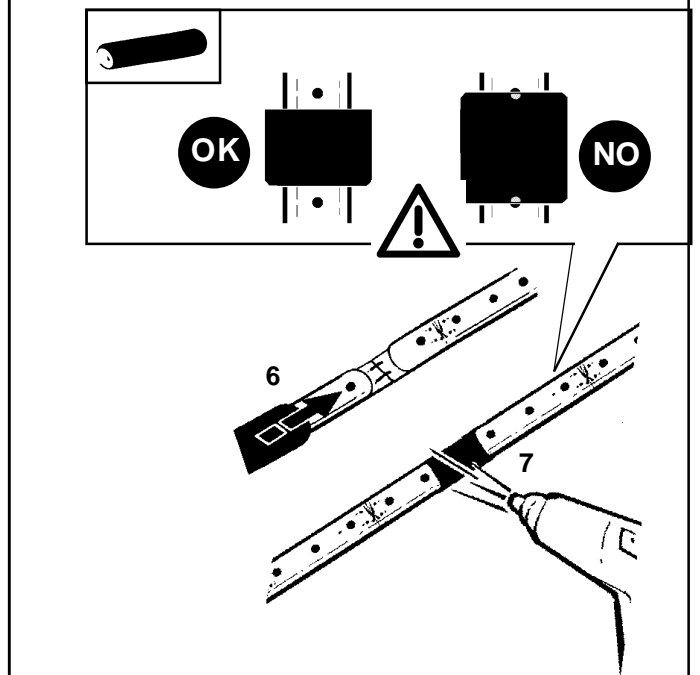
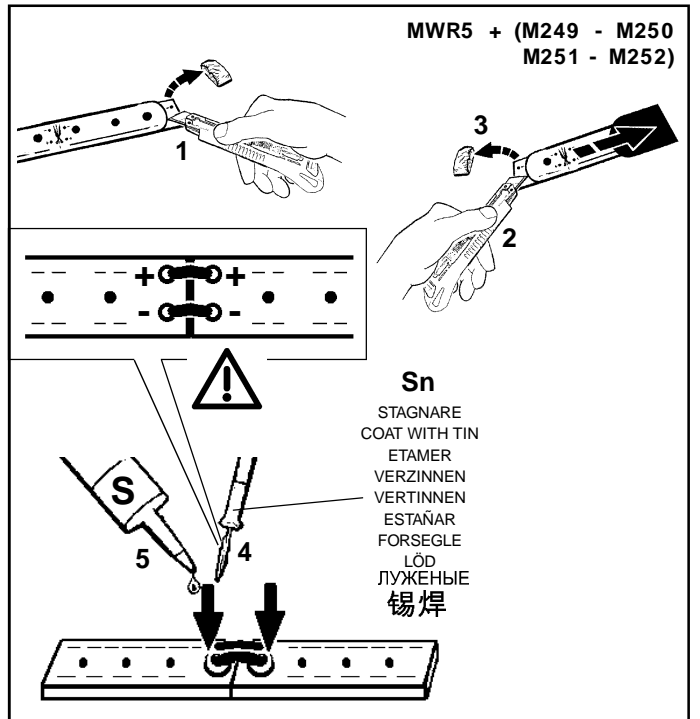
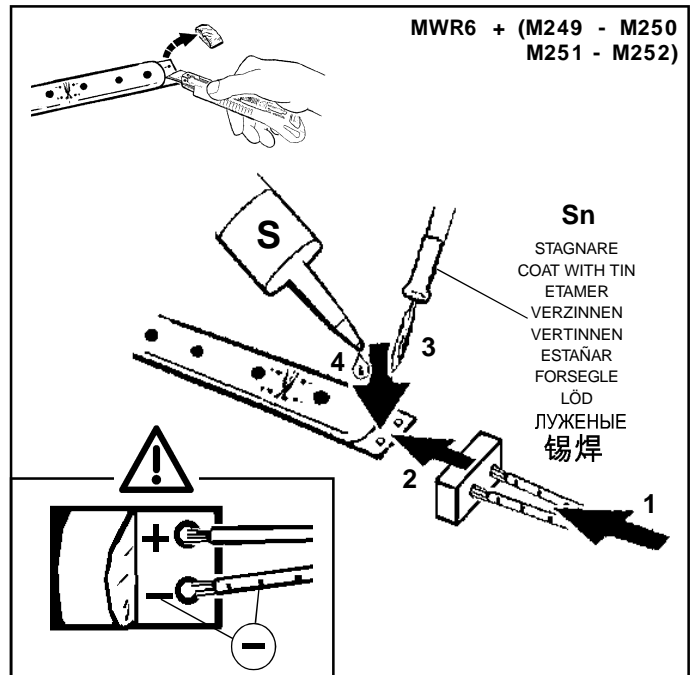
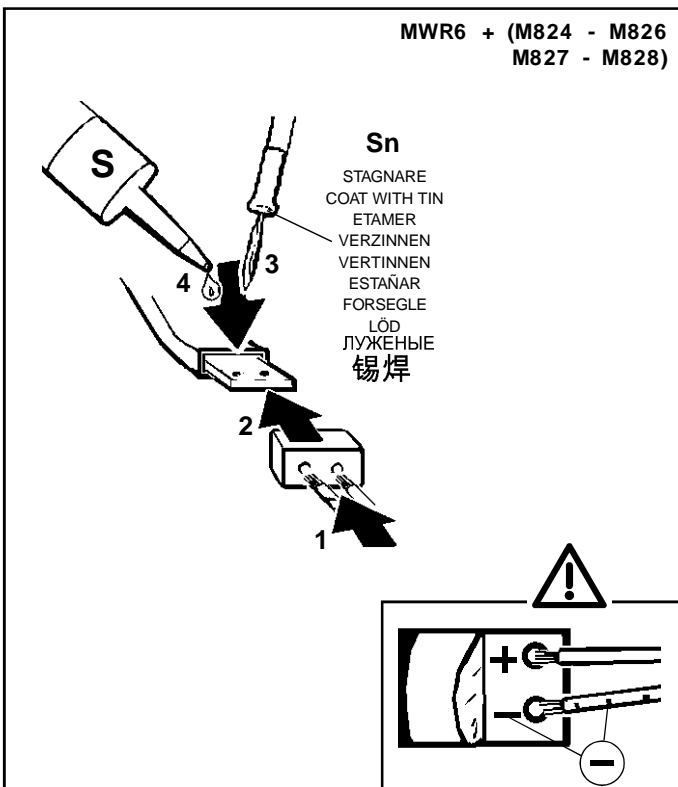
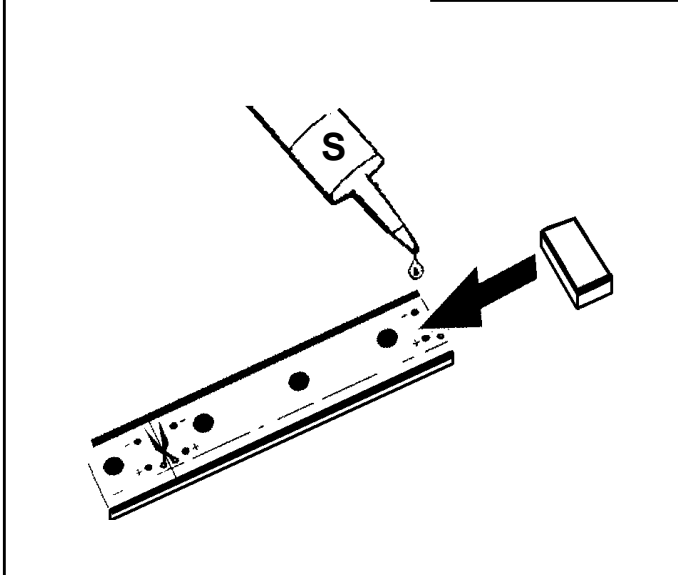
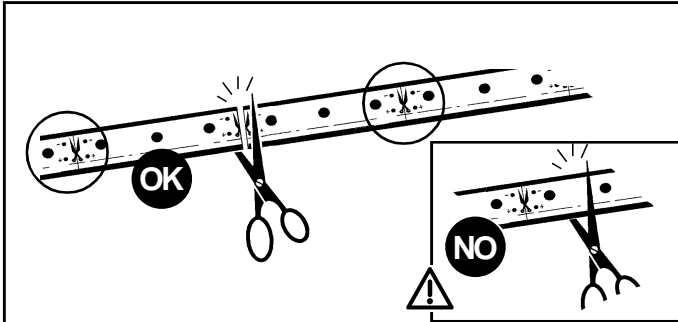
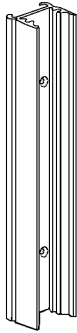

**MWR7 + (M253)**

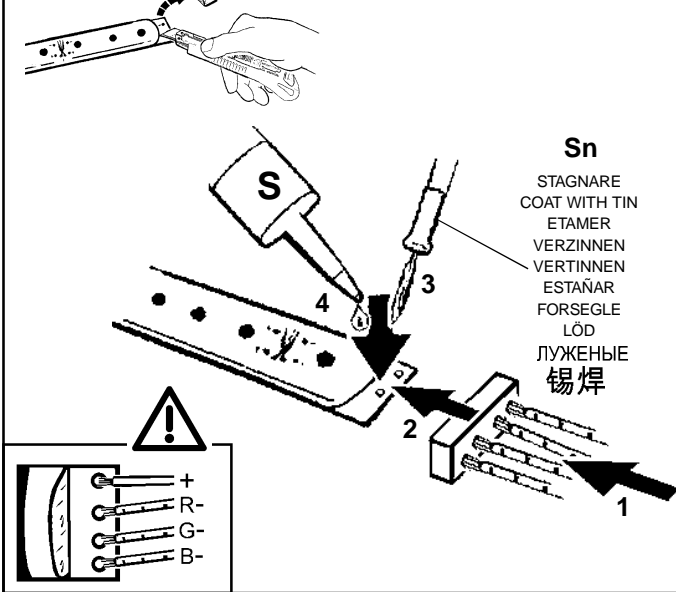

**MWR5 + (M253)**

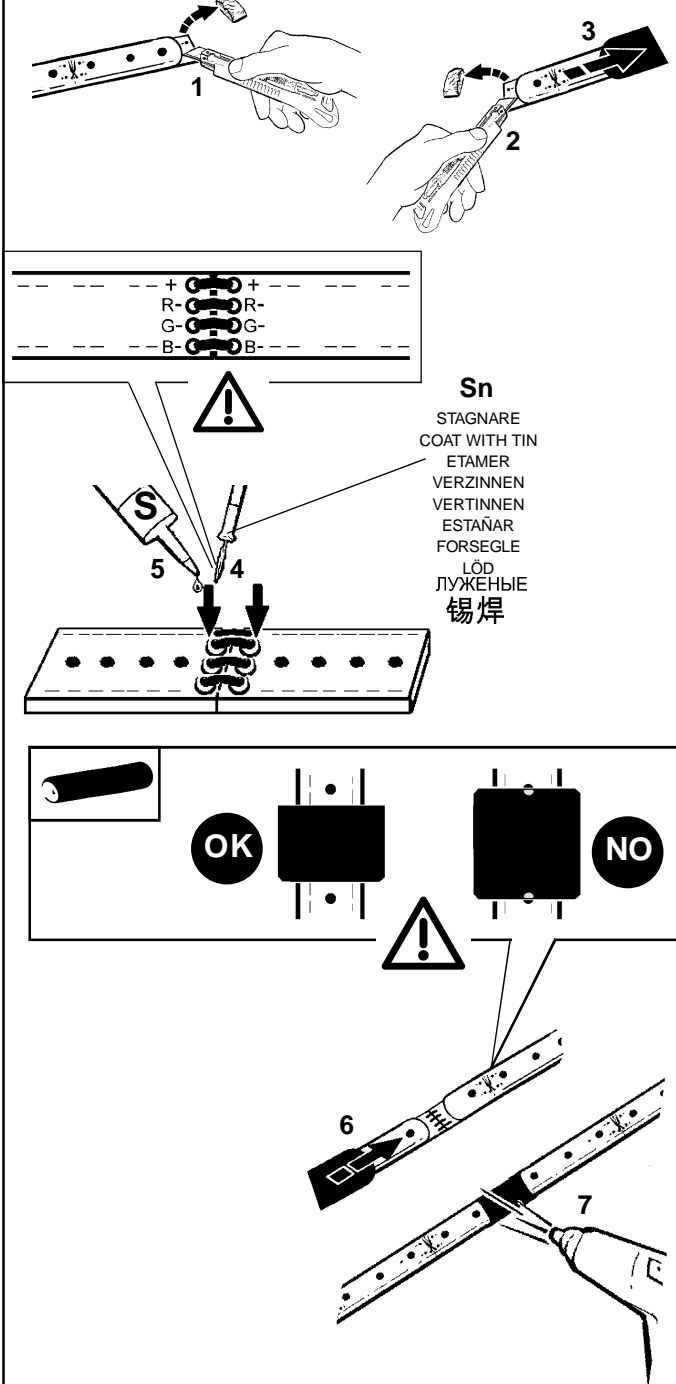

**I N.B.:** Il grado di protezione del sistema, è garantito soltanto se si effettua correttamente l'operazione di siliconatura **S**.

**GB N.B.:** The degree of protection offered by the system is only guaranteed if the siliconisation procedure is performed correctly **S**.

**F N.B.:** L'indice de protection du système n'est assuré que si l'application de silicone a été effectuée correctement **S**.

**D N.B.:** Der Schutzgrad des Systems ist nur gewährleistet, wenn die Silikonabichtung korrekt ausgeführt wird **S**.

**NL N.B.:** De beschermingsgraad van het systeem is alleen dan gegarandeerd als het silicone goed is aangebracht **S**.

**E N.B.:** El grado de protección del sistema está garantizado sólo si se realiza correctamente la operación de siliconado **S**.

**DK N.B.:** Beskyttelsesgraden på systemet kan kun garanteres hvis der påføres silikone på korrekt vis **S**.

**N N.B.:** Graden av beskyttelse som tilbys av systemet garanteres kun hvis silikonprosedyren utføres riktig **S**.

**S OBS!** Systemets skyddsgrad garanteras endast om silikoniseringsproceduren utförs på ett korrekt sätt **S**.

**RUS ПРИМЕЧАНИЕ:** Класс электробезопасности системы гарантируется, только если будет правильно выполнена пропитка силиконом.

**CN 注意事项:** 只有在正确地施行了聚硅酮操作之后系统保护的等级才被保证。**S**

art. M824 - M826  
M827 - M828

**Sn**

STAGNARE  
COAT WITH TIN  
ETAMER  
VERZINNEN  
VERTINNEN  
ESTAÑAR  
FORSEGLE  
LÖD  
ЛУЖЕНЫЕ  
錫焊

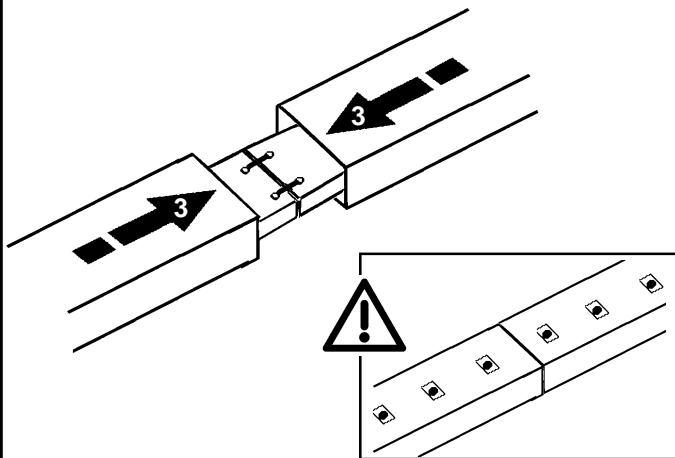
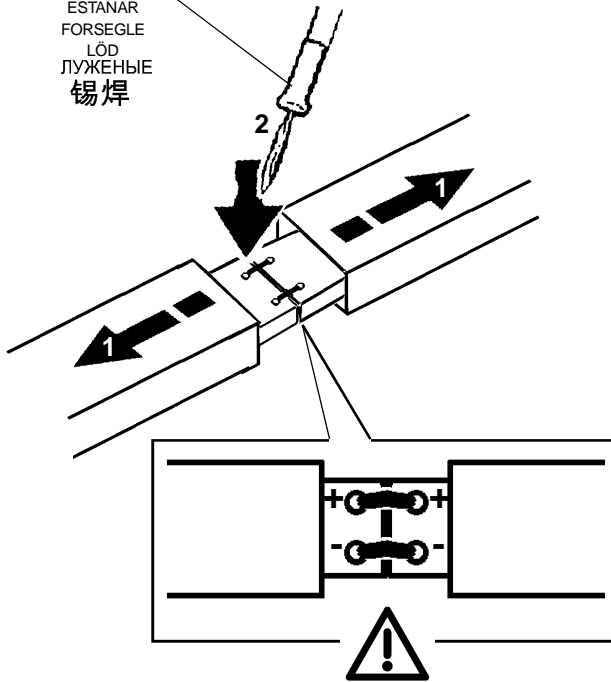

- I N.B.: Con questa operazione non viene più garantito il grado di protezione  
 GB N.B.: The protection degree is no longer guaranteed after this operation.  
 F N.B.: Suite à cette opération, l'indice de protection n'est plus garanti  
 D N.B.: Durch Ausführen dieser Operation ist der Schutzgrad nicht mehr garantiert  
 NL N.B.: Als u deze handling uitvoert wordt de beschermingsgraad niet meer gegarandeerd  
 E N.B.: Con esta operación no se garantiza el grado de protección.  
 DK N.B.: Med denne handling garanteres beskyttelsesgraden ikke længere.  
 N N.B.: Med dette inngrepet er ikke beskyttelsesgraden garantert lenger.  
 S **OBS!** Skyddsklassen garanteras inte efter att denna operation har utförts.  
 RUS ПРИМЕЧАНИЕ: При выполнении этой операции степени защиты более не гарантируется  
 CN 注意：进行此操作后将无法保证其防护等级。

ART	A (mm)
MXK3 - MXK4 - MXK6 -MXK7 MXK8 - MXK9 - MXL0 - MXL1 MXL2 - MXL3 - MXQ3	12
MXK5 - MXN8 - MXQ4 - MXQ5	2

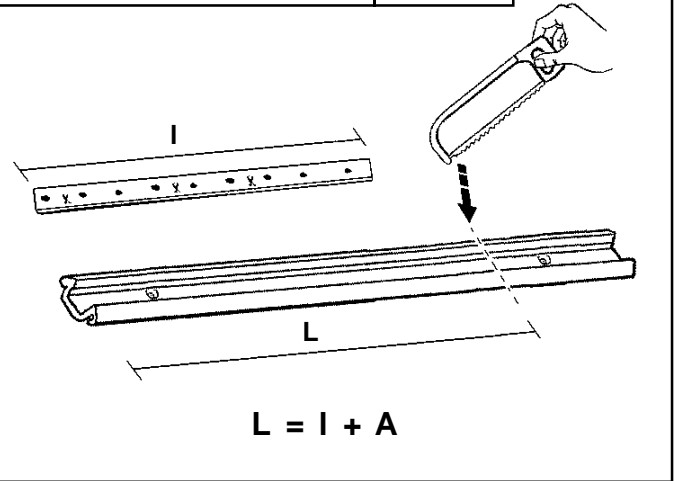



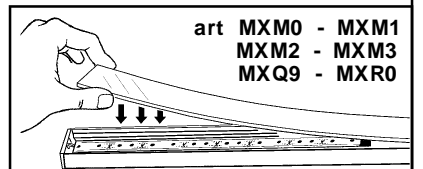
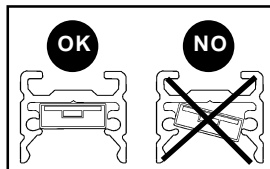
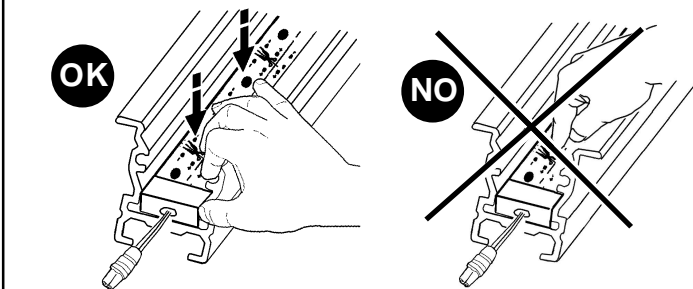
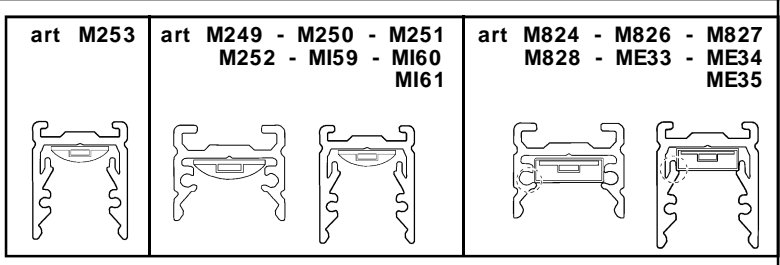
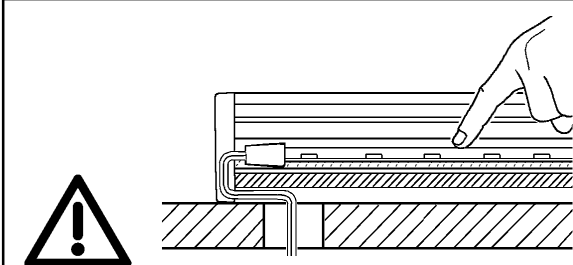
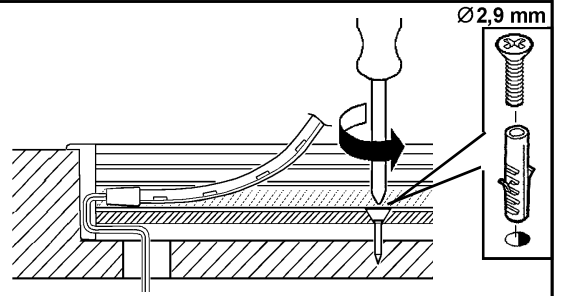
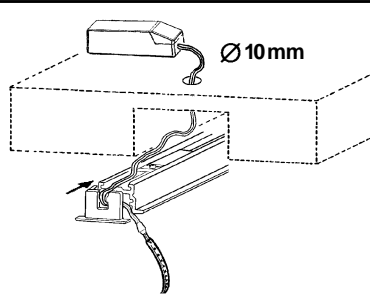
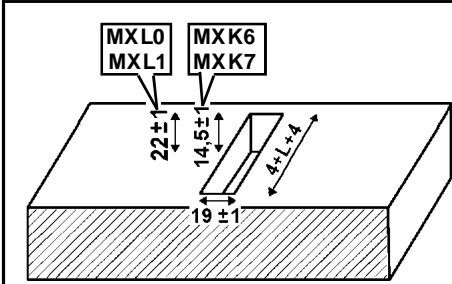
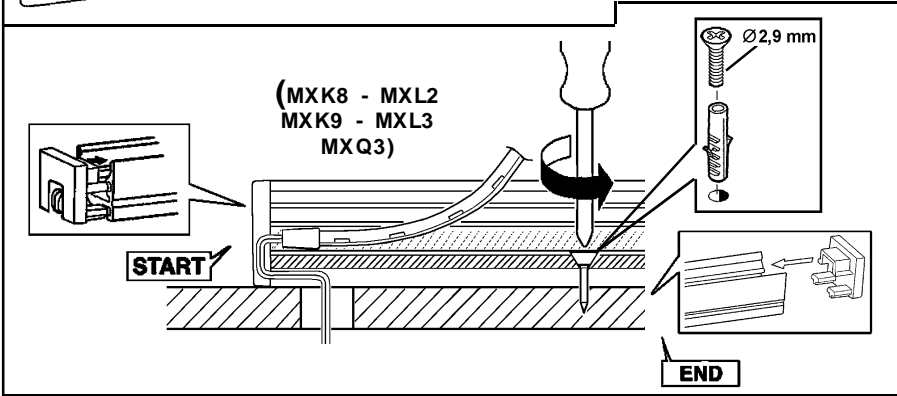
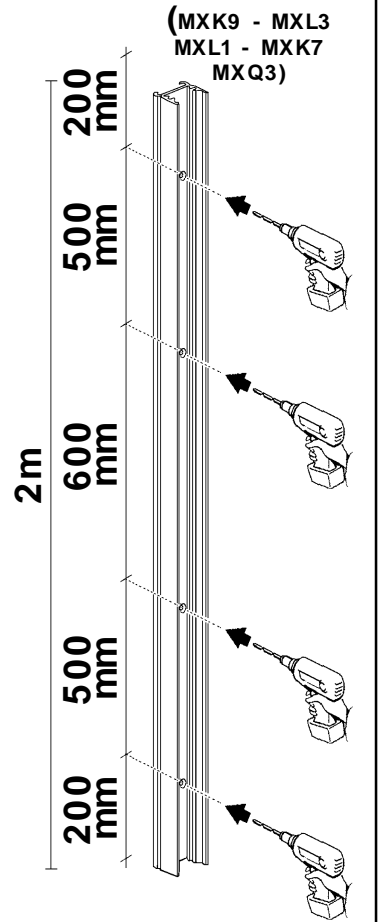
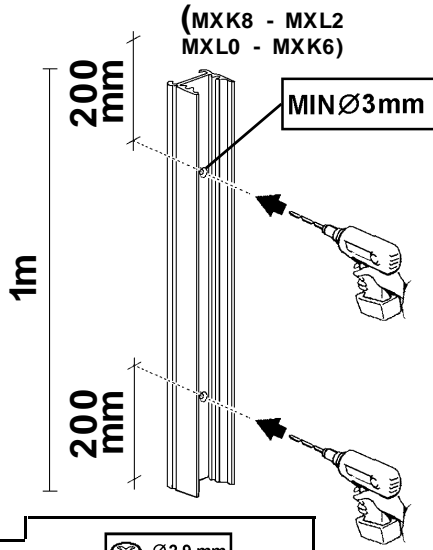
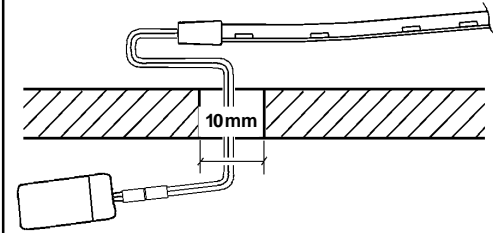
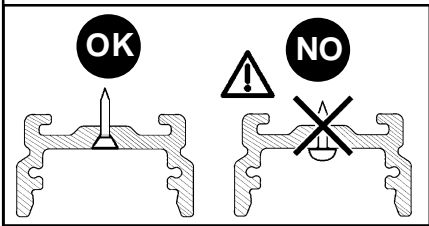
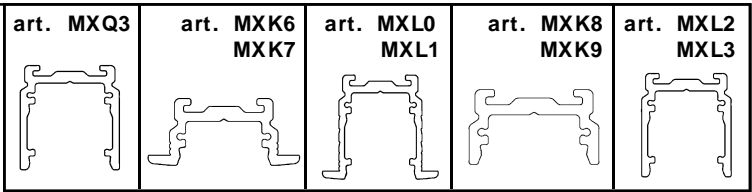
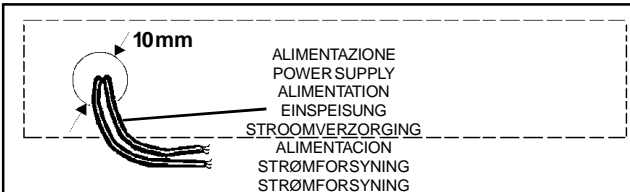

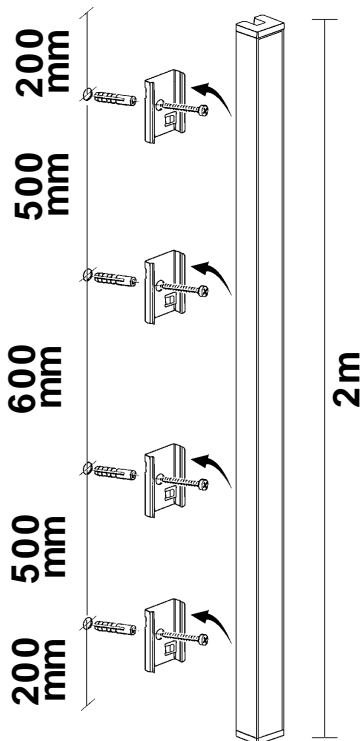
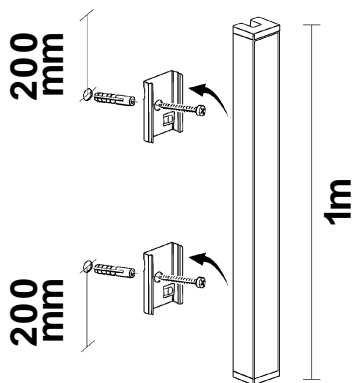
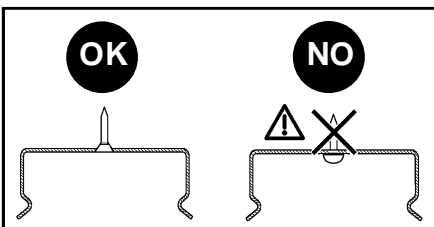

art.  
MXM4

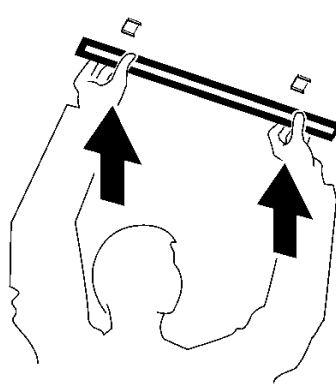
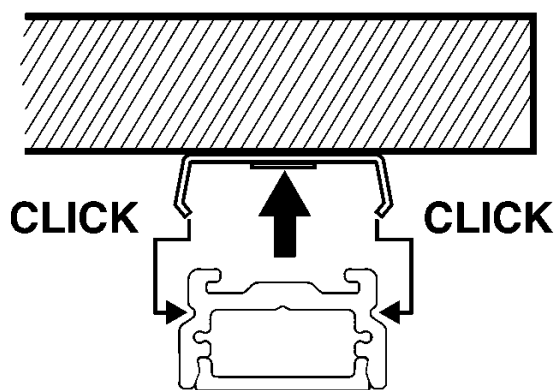
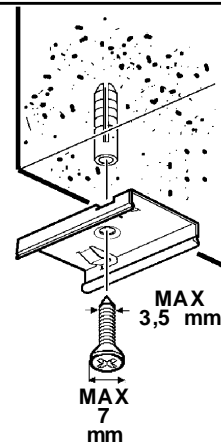



ALIMENTAZIONE  
 POWER SUPPLY  
 ALIMENTATION  
 EINSPEISUNG  
 STROOMVERZORGING  
 ALIMENTACION  
 STRØMFORSYNING  
 STRØMFORSYNING  
 ELFØRSØRNING  
 ЭЛЕКТРОПИТАНИЕ  
 电源

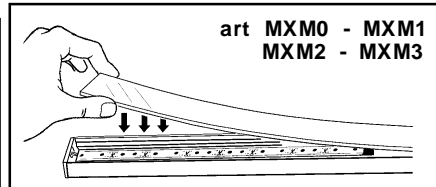
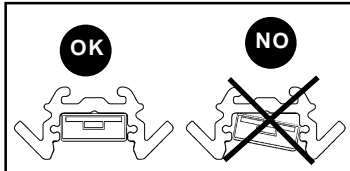
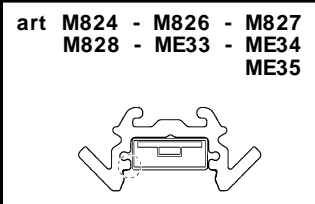
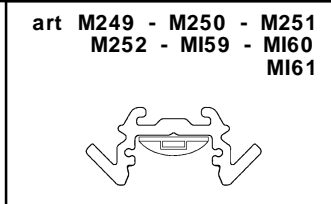
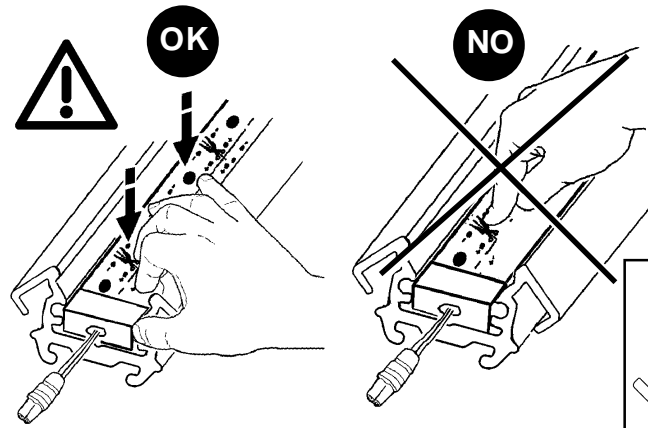
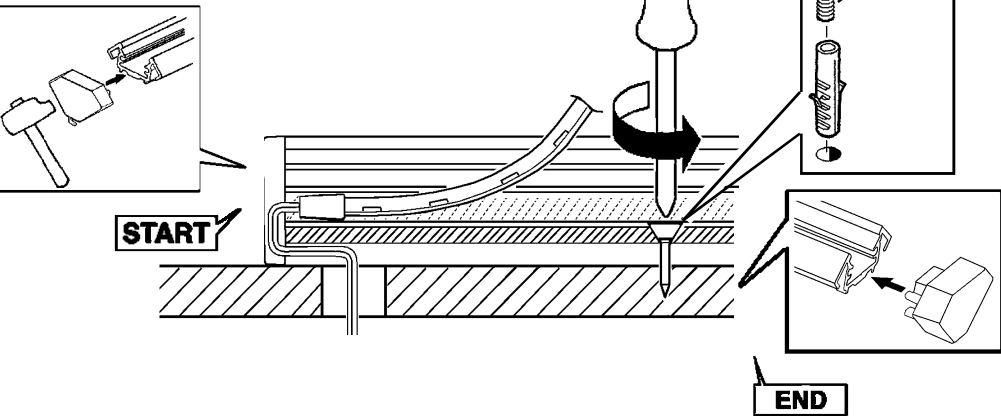
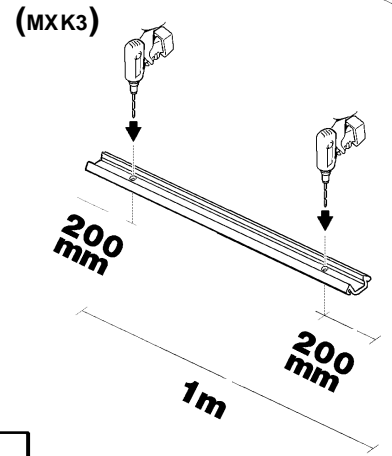
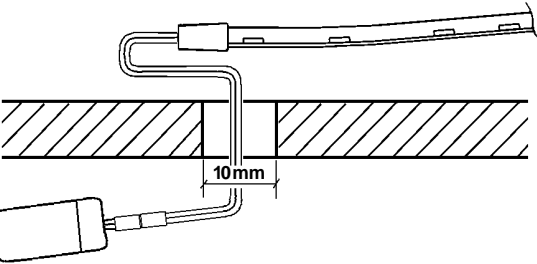
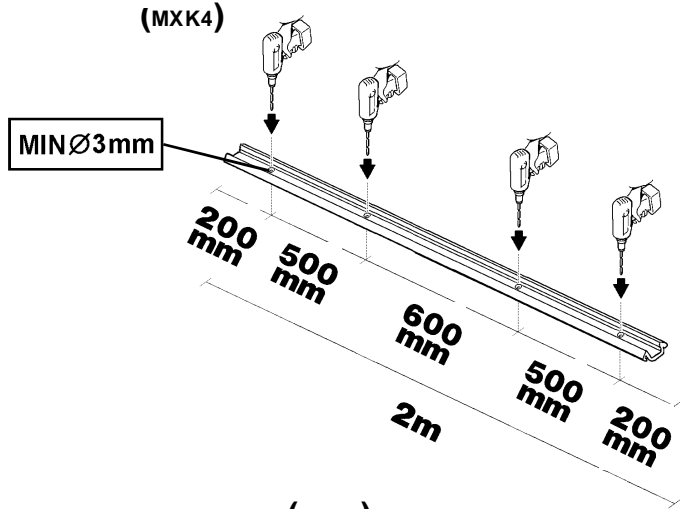
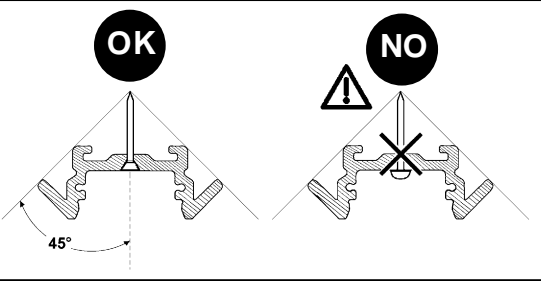
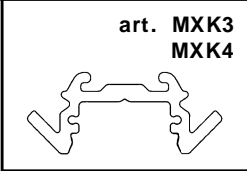

(MXK4)

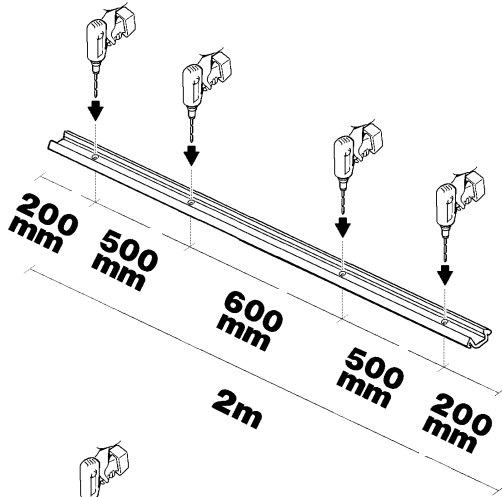

(MXK3)

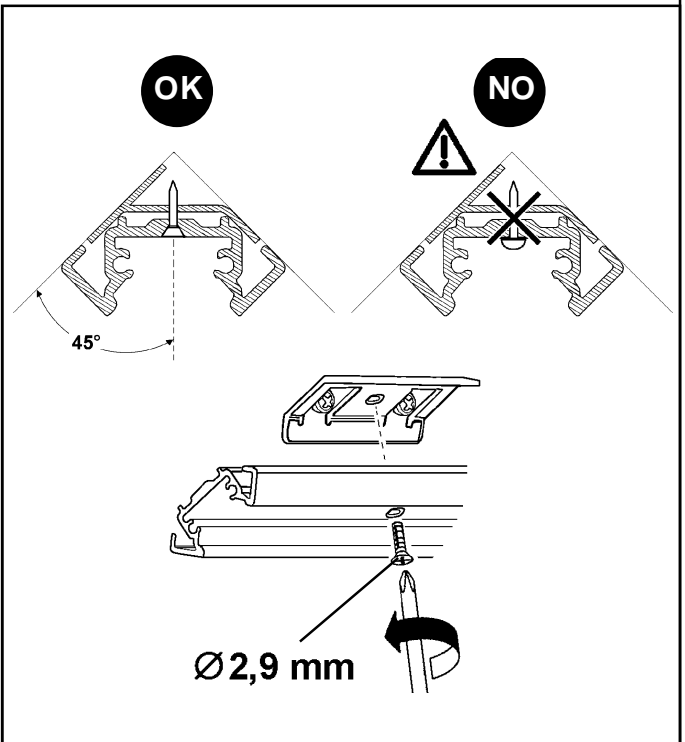
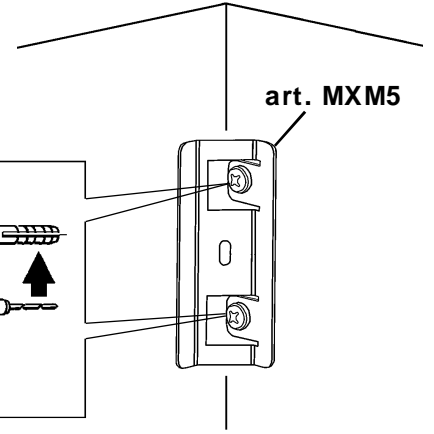
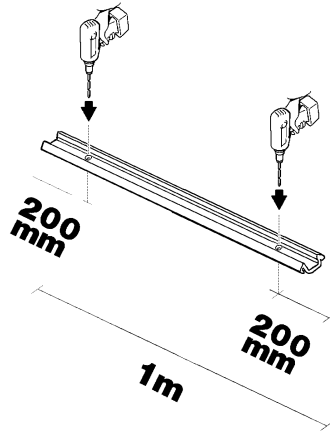

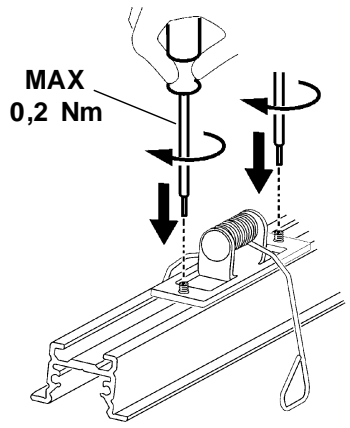
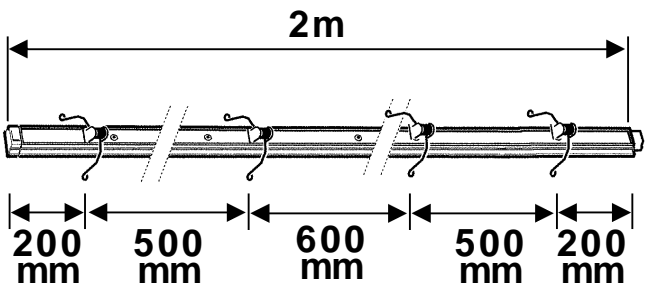
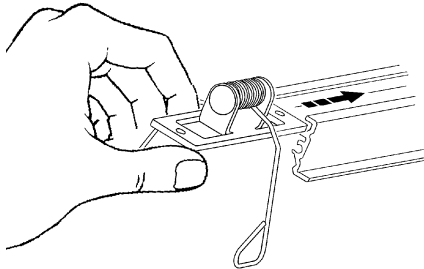
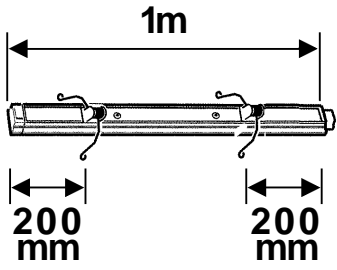
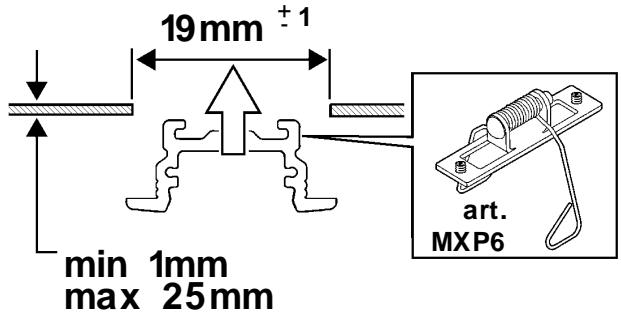
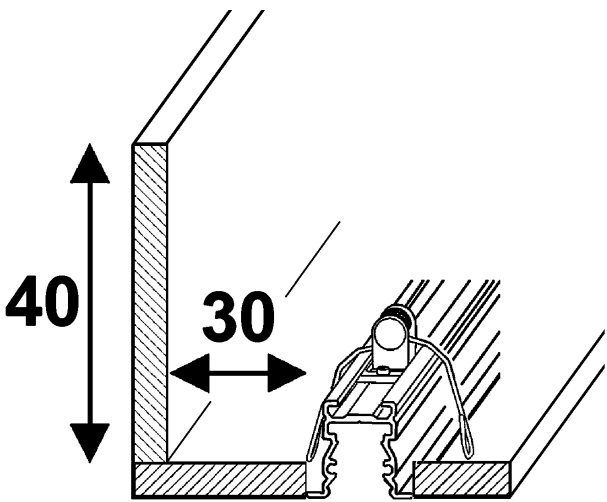
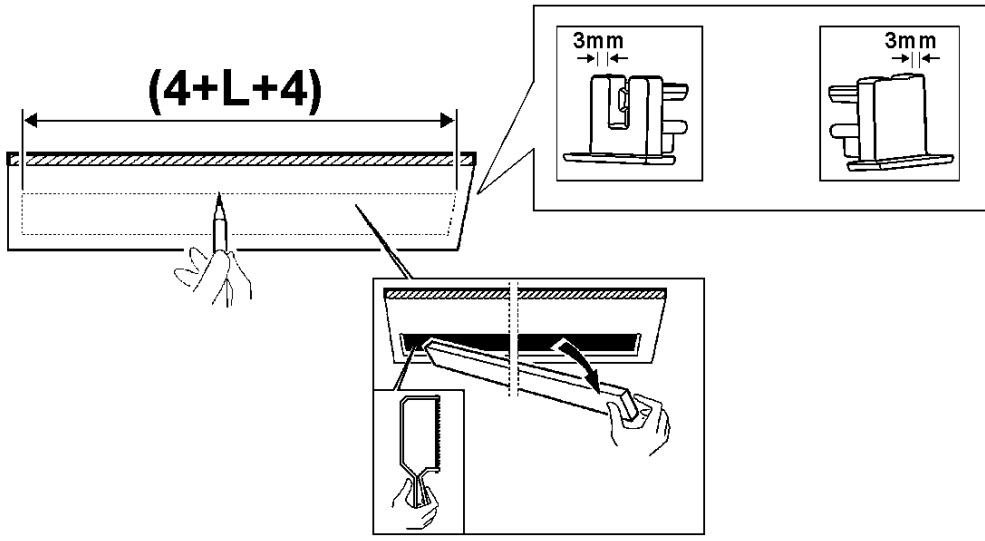
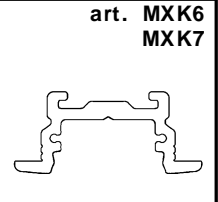
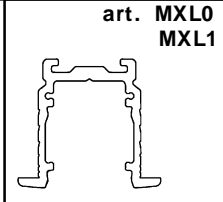

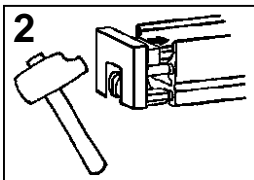
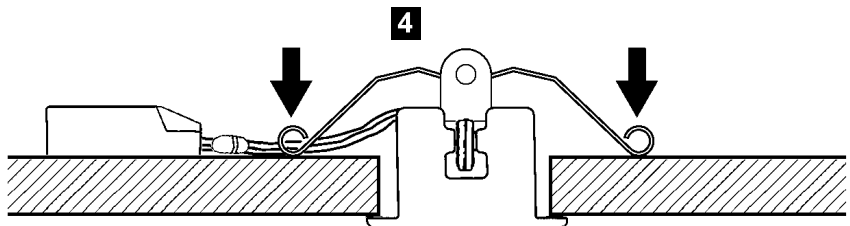
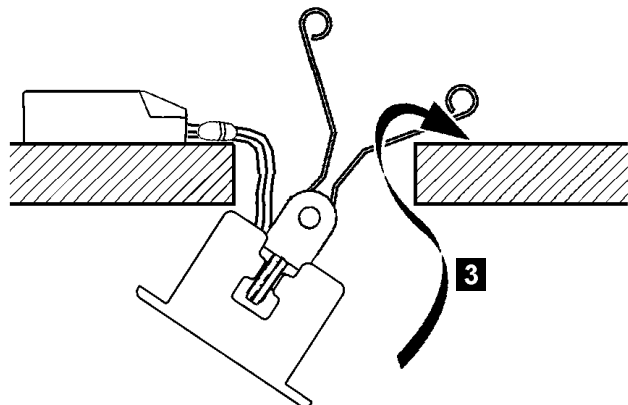
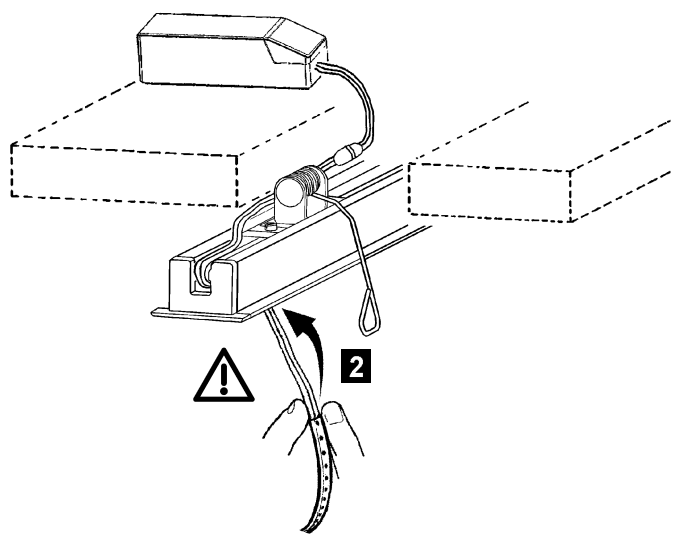
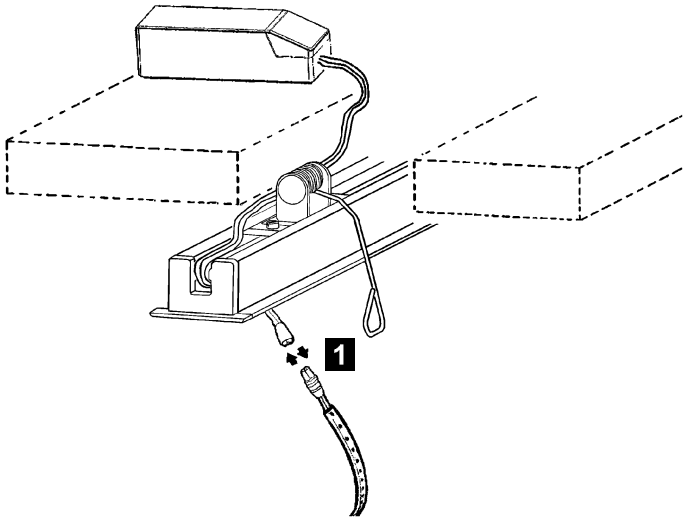

**START**

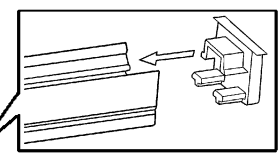
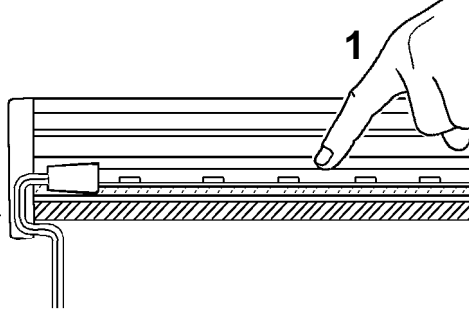

**END**

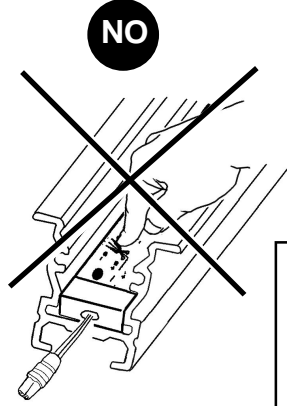
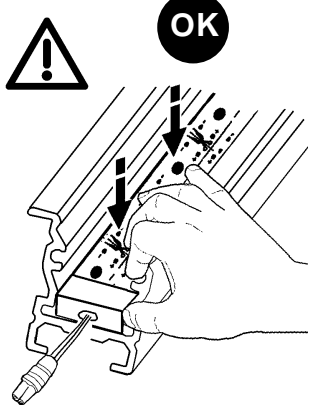

art M249 - M250 - M251  
M252 - MI59 - MI60  
MI61

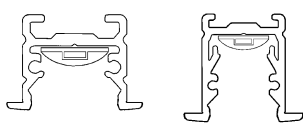

art M824 - M826 - M827  
M828 - ME33 - ME34  
ME35

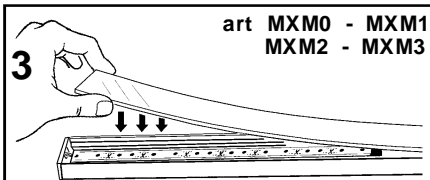
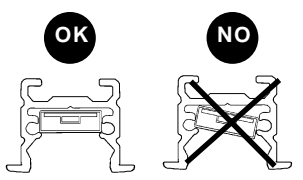
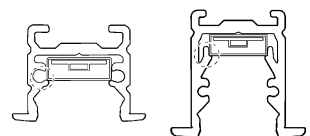

art MXM0 - MXM1  
MXM2 - MXM3

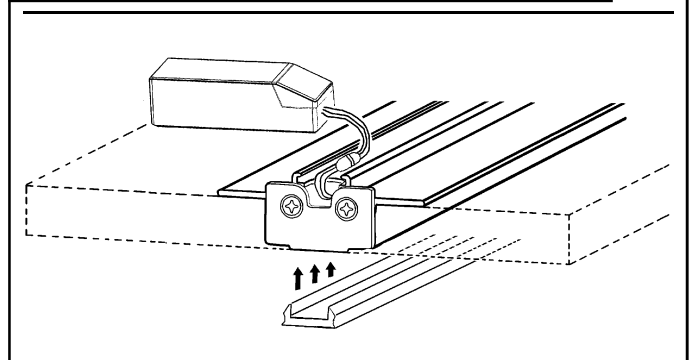
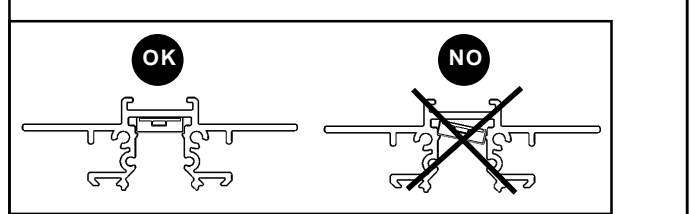
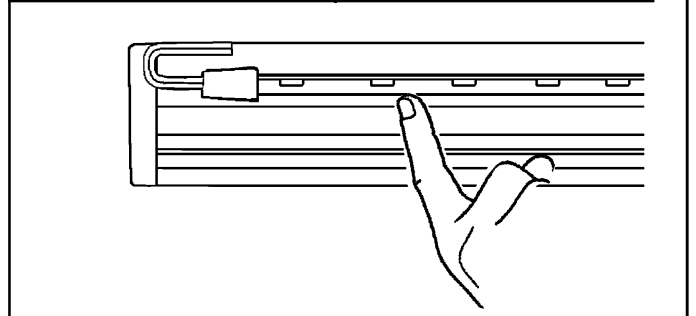
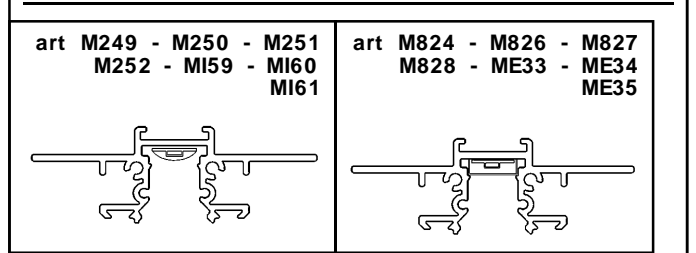
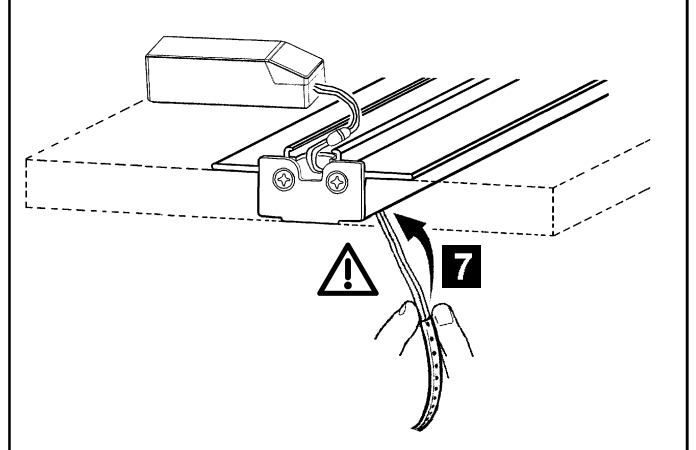
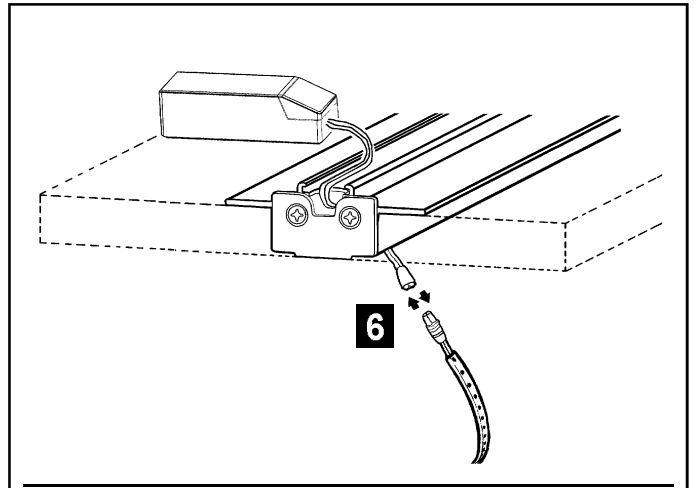
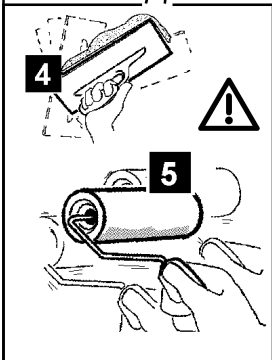
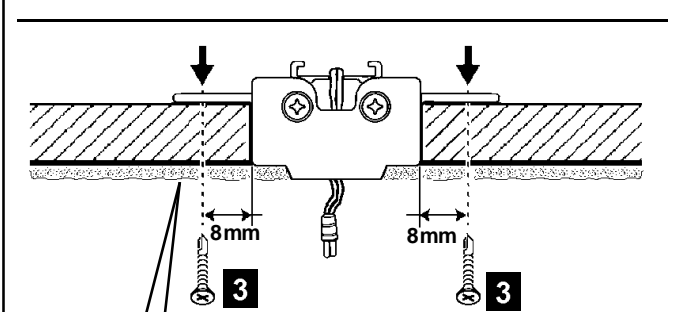
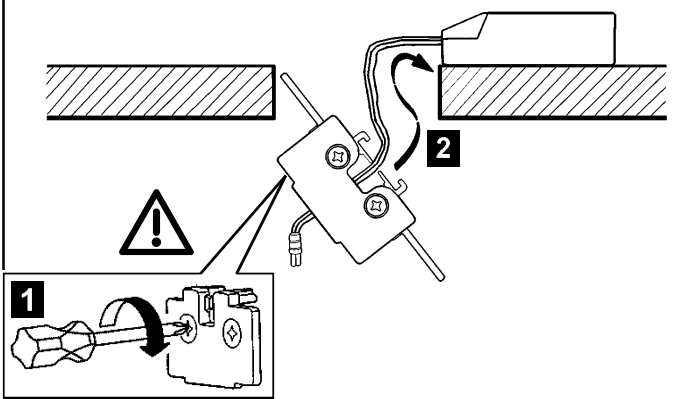
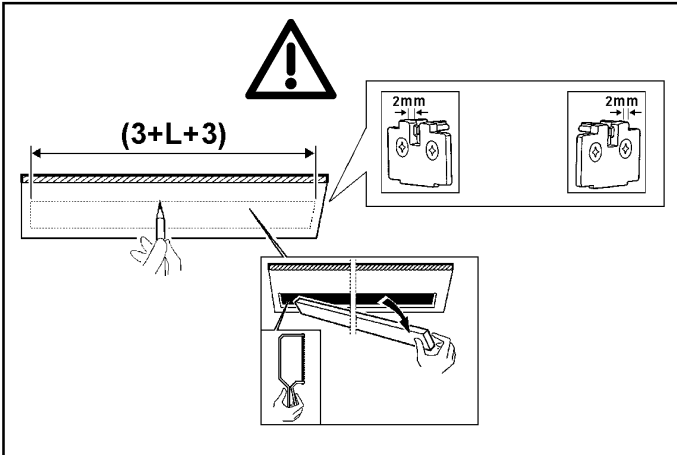
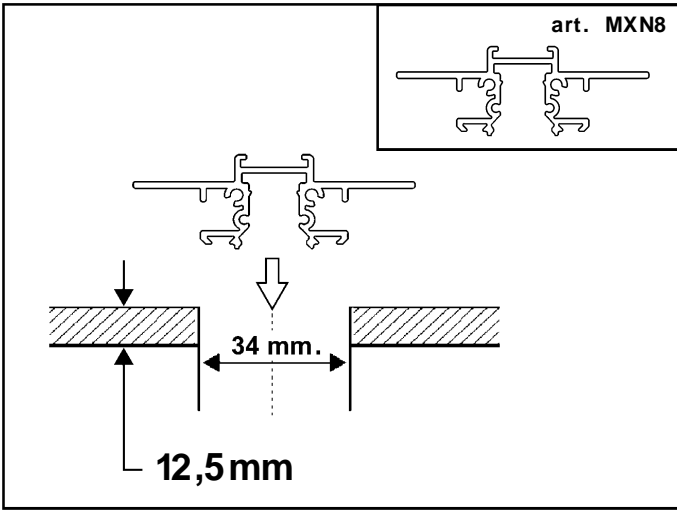

art. MXQ4

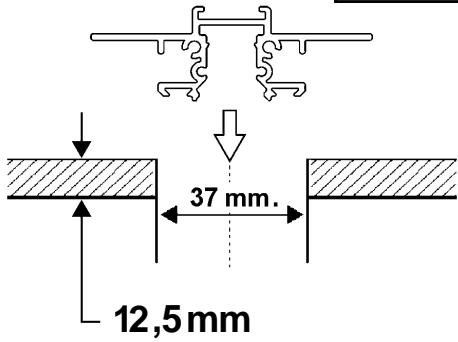

(3+L+3)

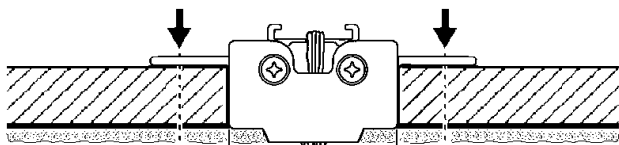
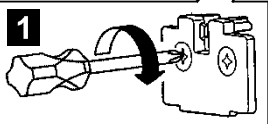
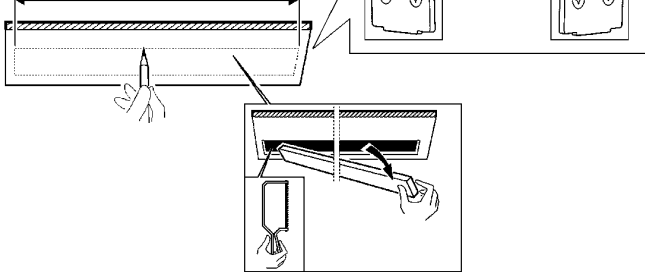

3

3



5

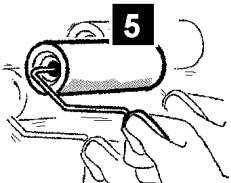

Sn

STAGNARE  
COAT WITH TIN  
ETAMER  
VERZINNEN  
VERTINNEN  
ESTAÑAR  
FORSEGLE  
LÖD  
ЛУЖЕНЫЕ  
锡焊

6

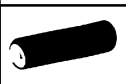
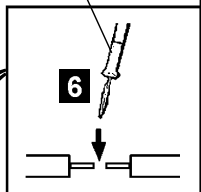
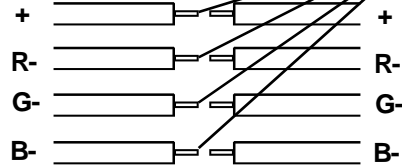

7

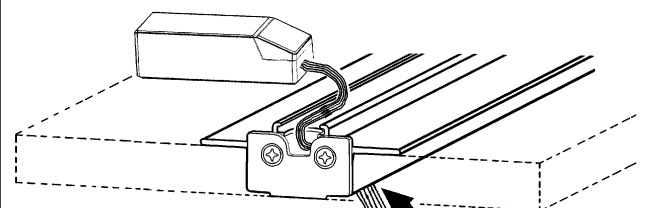
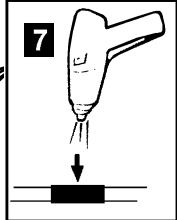
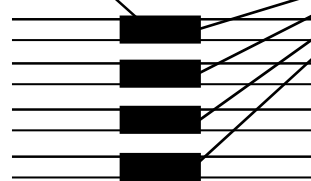

8

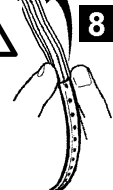



art M253

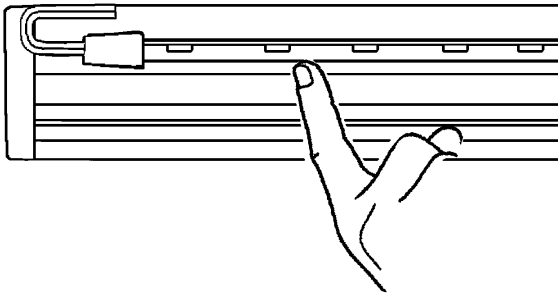
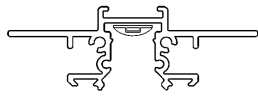

art. MXK5

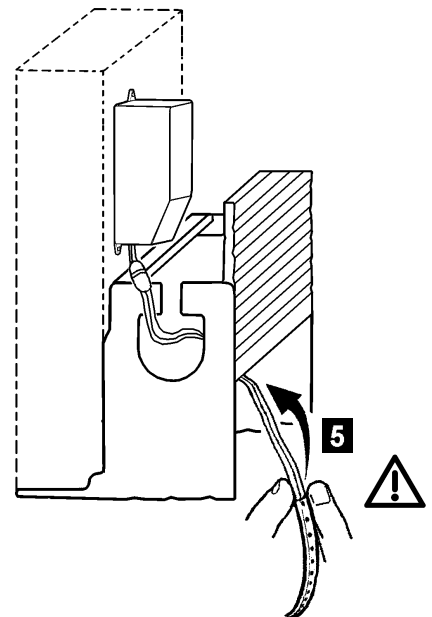
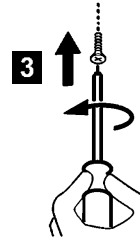
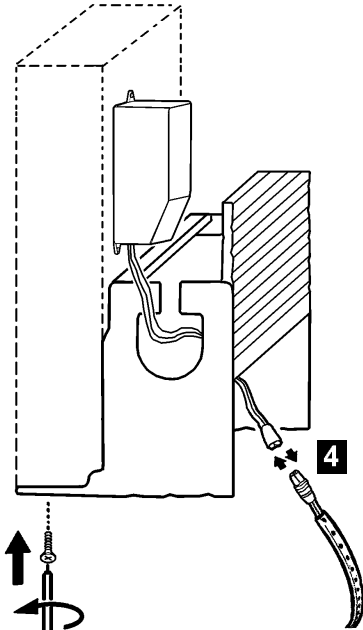
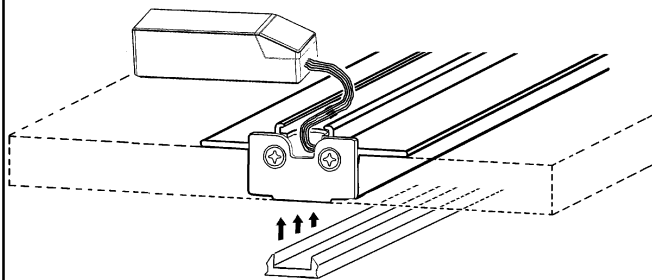
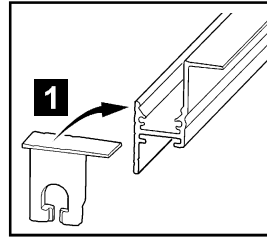
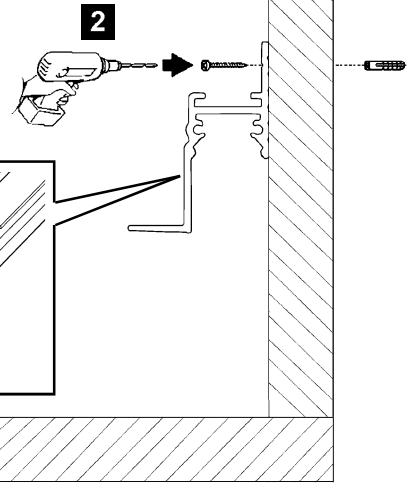
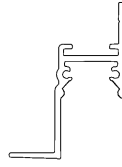

art. MXK5

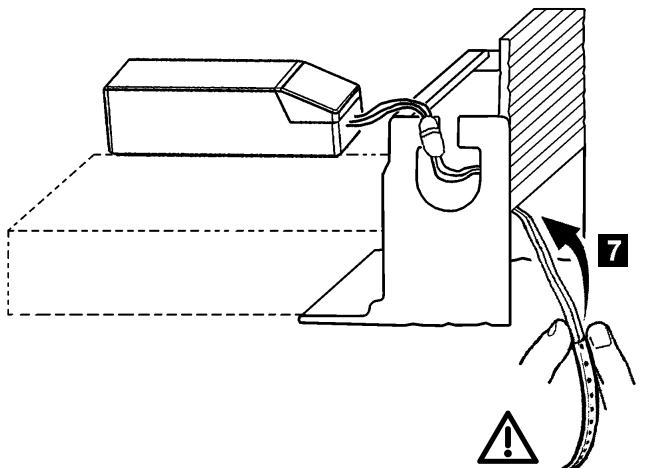
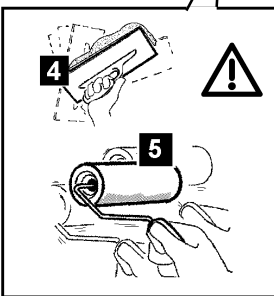
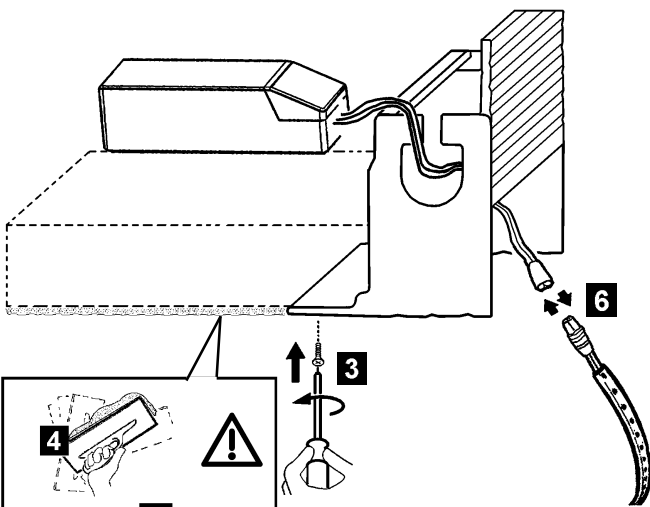
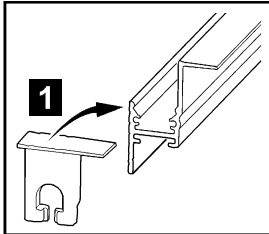
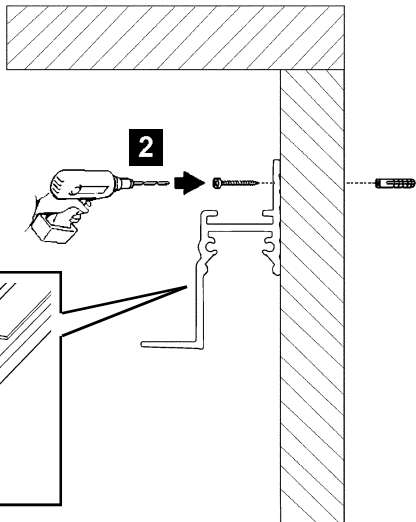
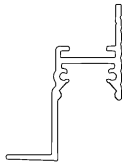

art M249 - M250 - M251  
M252 - MI59 - MI60  
MI61

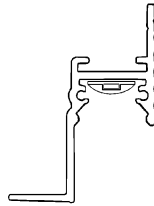

art M824 - M826 - M827  
M828 - ME33 - ME34  
ME35

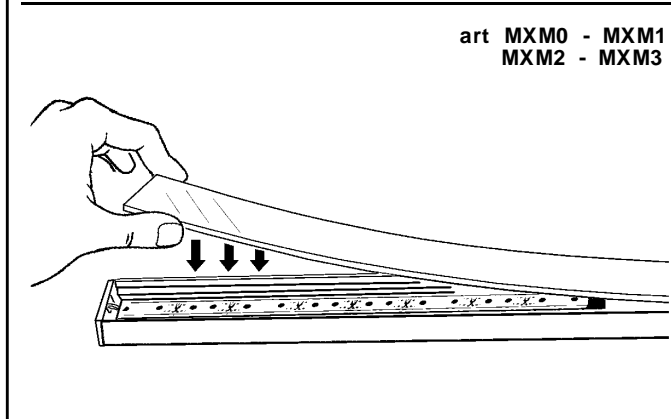
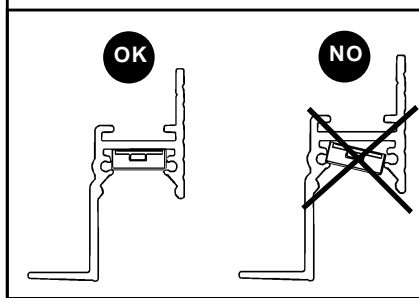
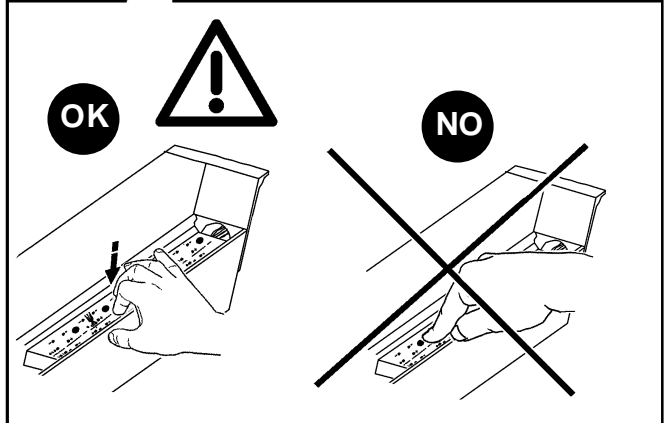
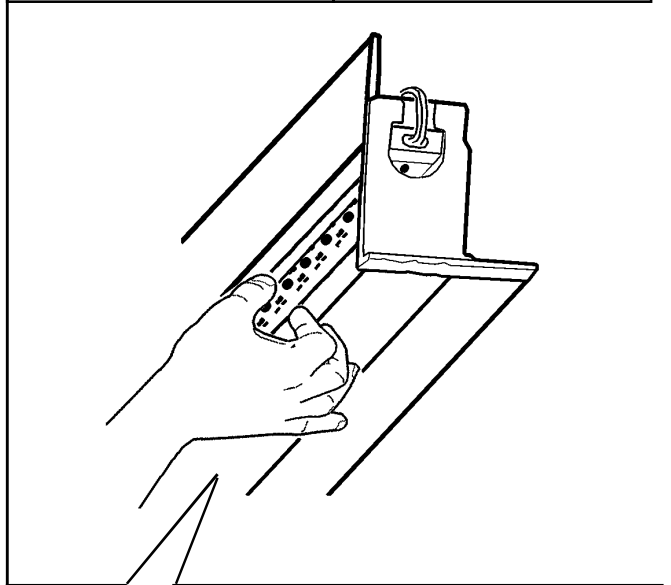
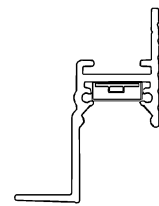

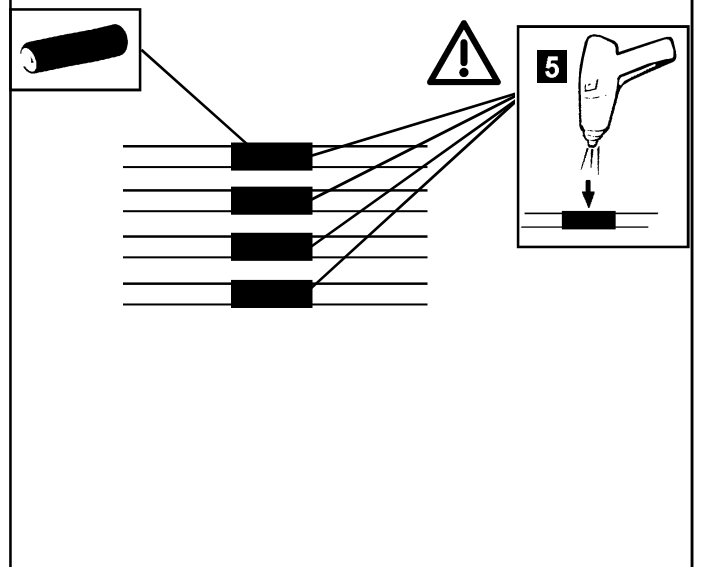
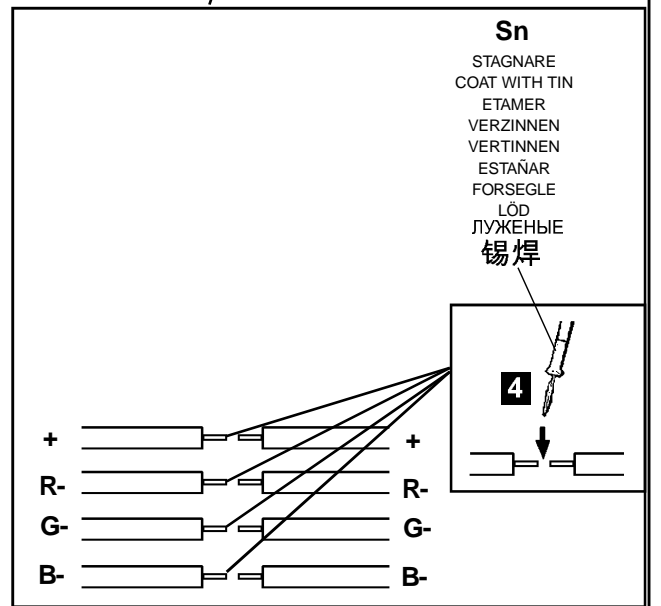
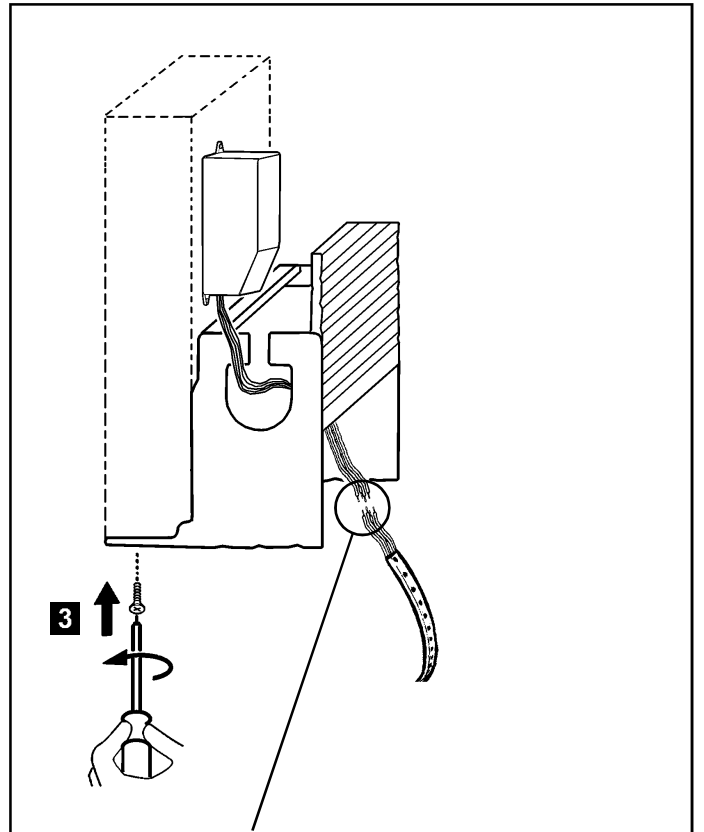
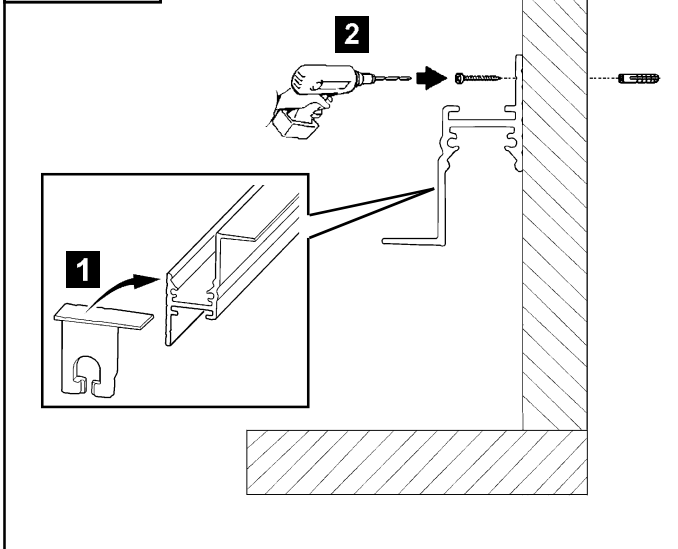
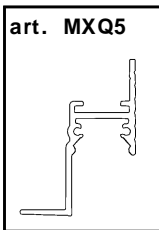
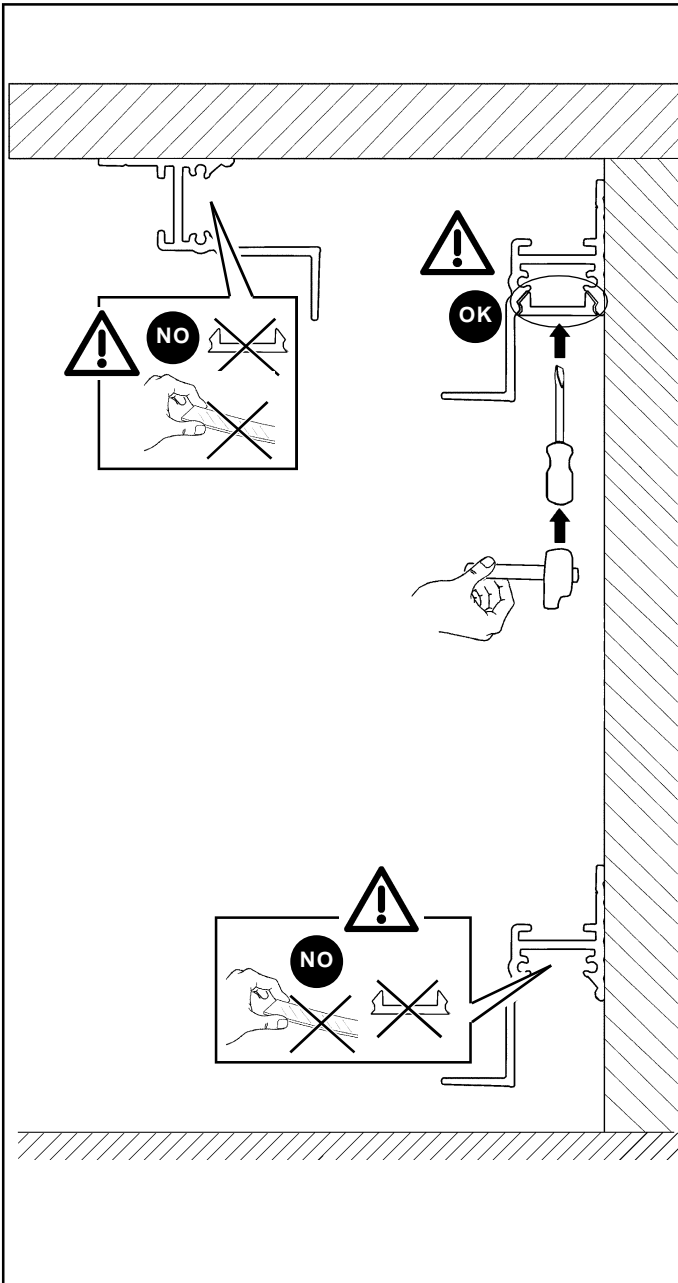

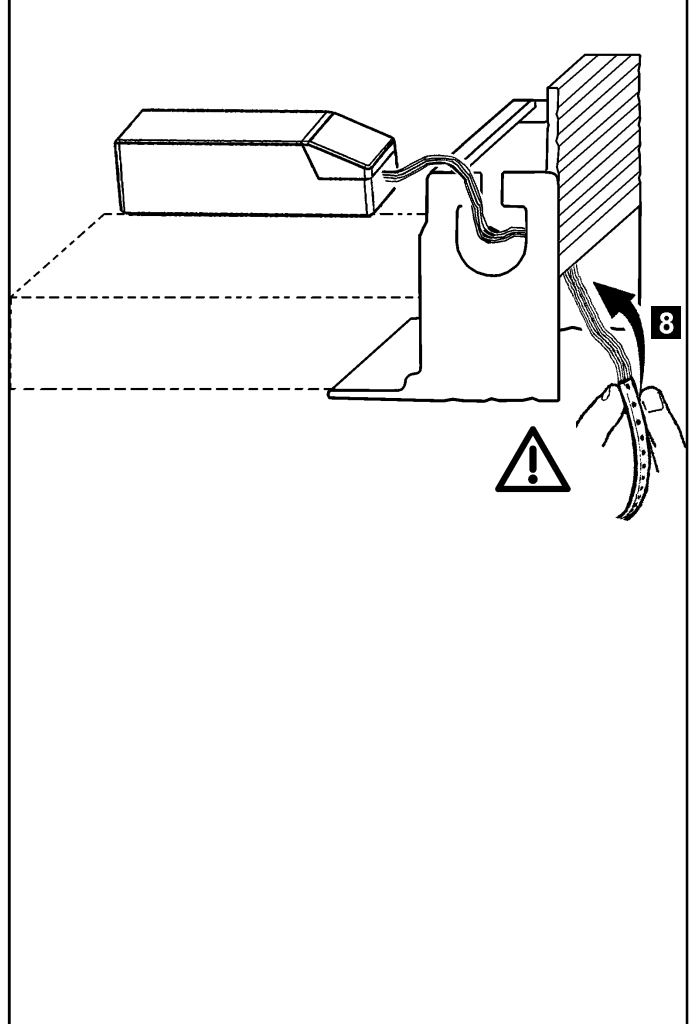
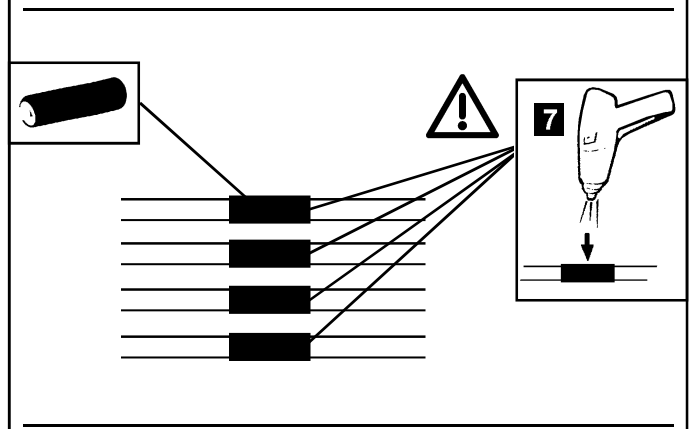
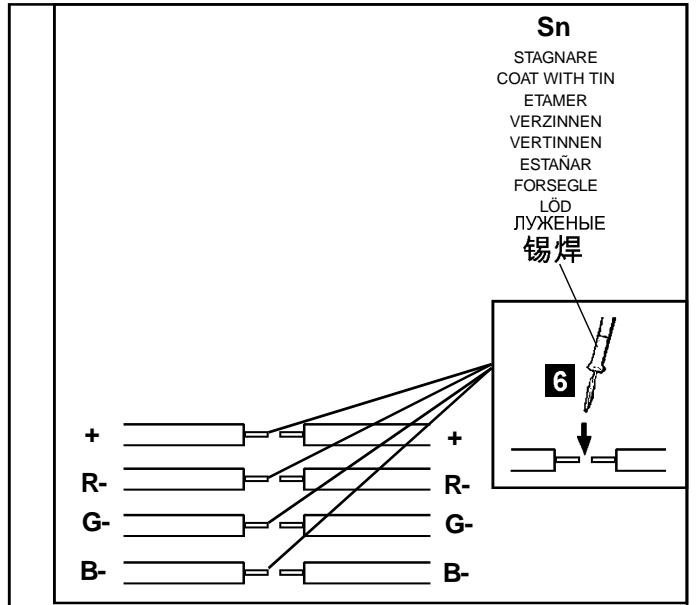
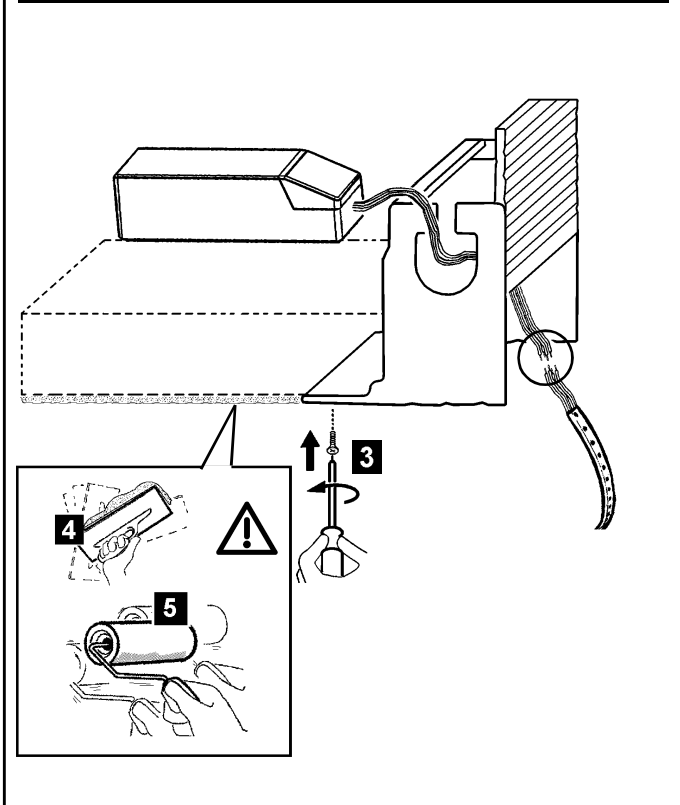
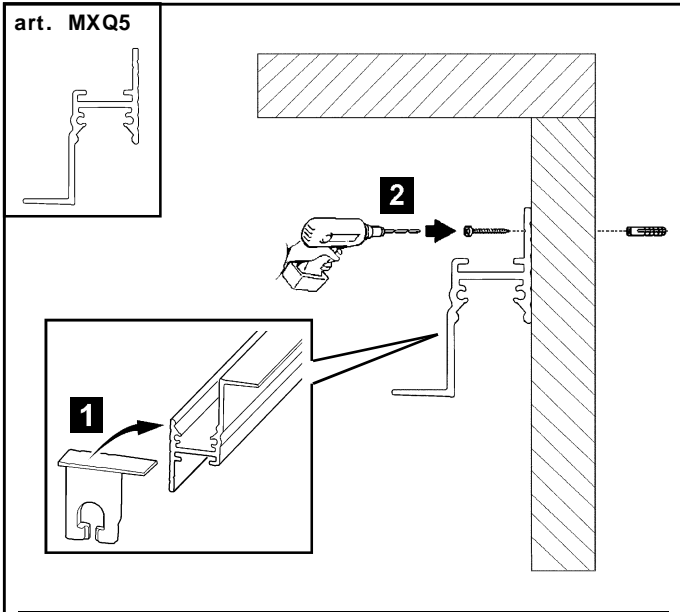
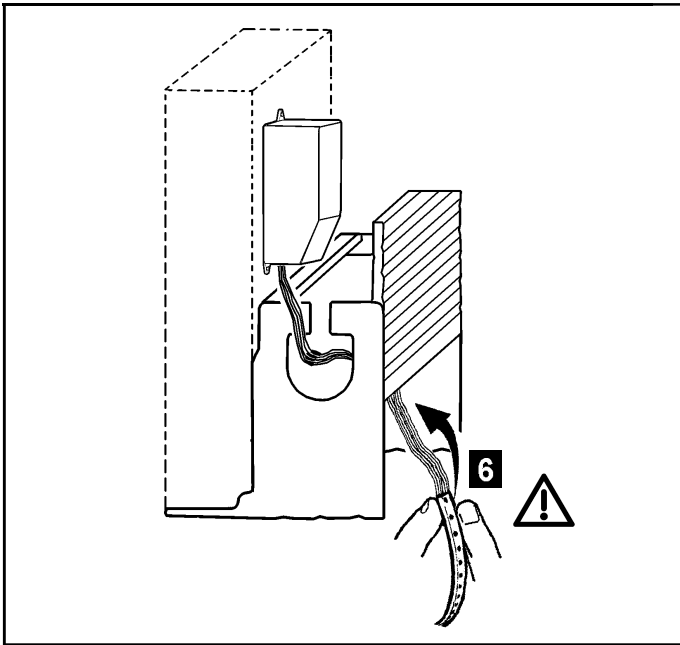

art M253

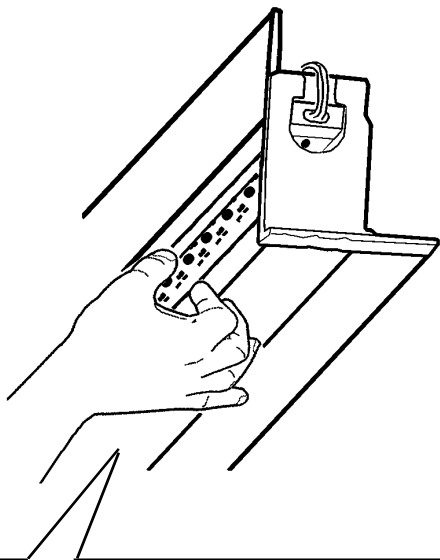
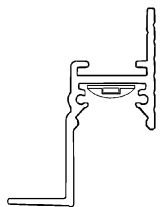

OK

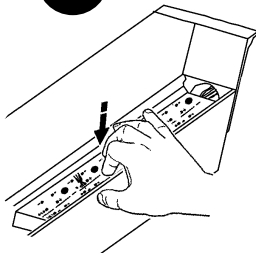

NO

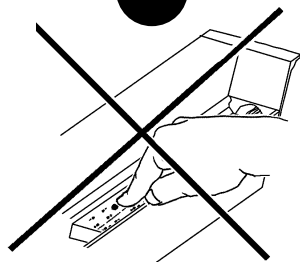

art MXQ9 - MXR0

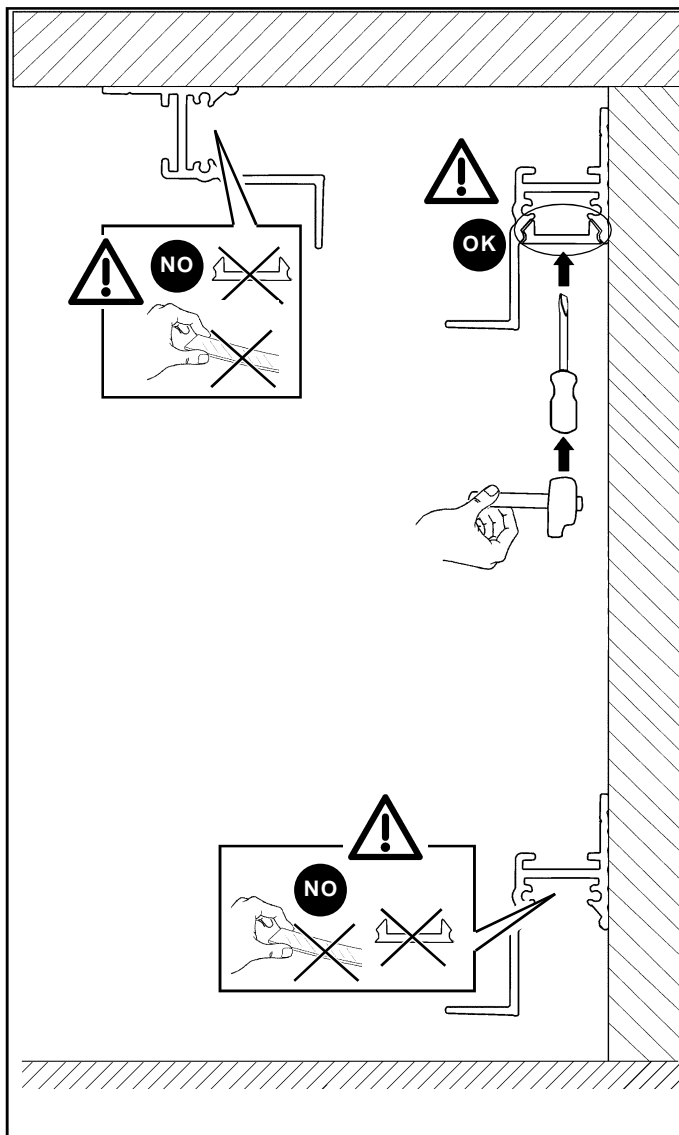
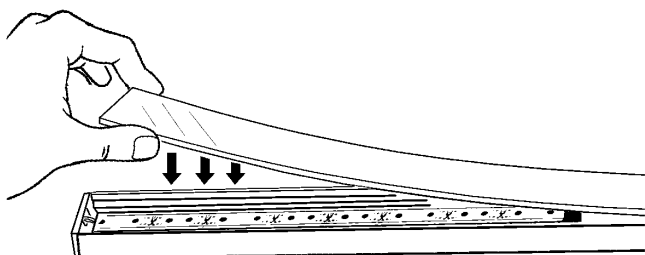

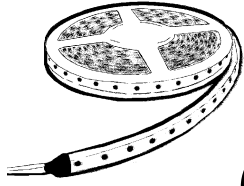

## LEDSTRIP (underscore)

تحذير:

لا يمكن ضمان سلامة هذا الجهاز إلا إذا التزمت بهذه التعليمات. يجب حفظها في مكان آمن.

**ATTENZIONE:**

LA SICUREZZA DELL'APPARECCHIO E' GARANTITA SOLO CON L'USO APPROPRIATO DELLE SEGUENTI ISTRUZIONI; PERTANTO E' NECESSARIO CONSERVARLE.

**WARNING:**

THE SAFETY OF THIS FIXTURE IS GUARANTEED ONLY IF YOU COMPLY WITH THESE INSTRUCTIONS; REMEMBER TO CONSERVE IN A SAFE PLACE.

**ATENCION:**

LA SEGURIDAD DEL APARATO SE GARANTIZA SOLO CUMPLIENDO CUIDADOSAMENTE LAS SIGUIENTES INSTRUCCIONES; POR ELLO, ES NECESARIO CONSERVARLAS.

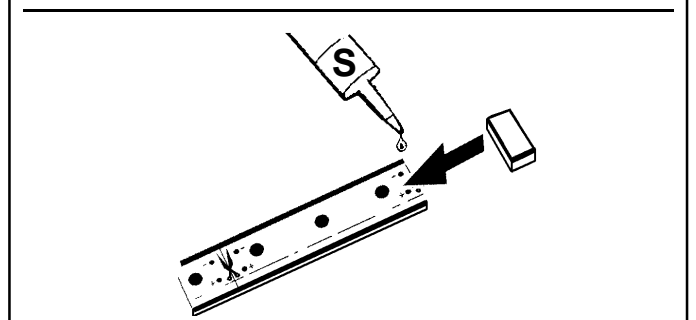
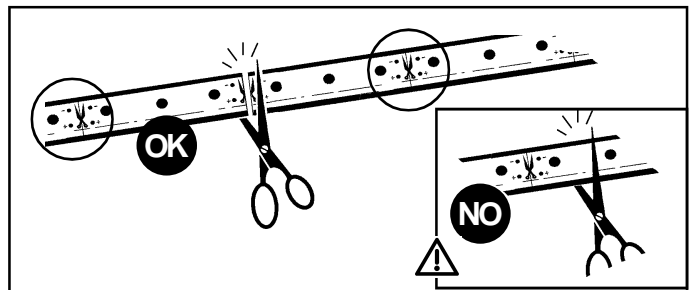
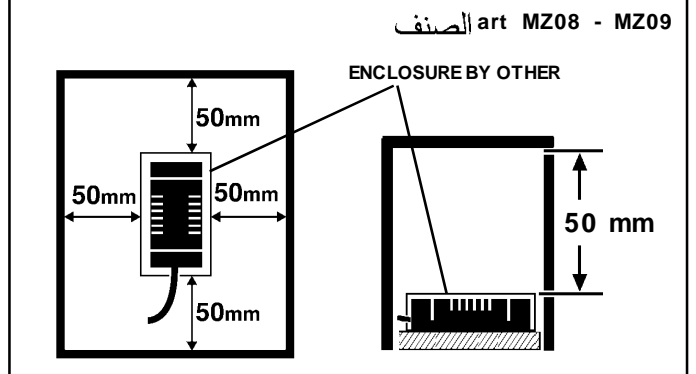
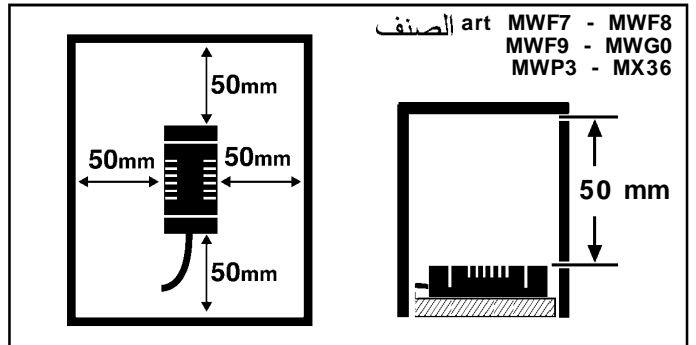
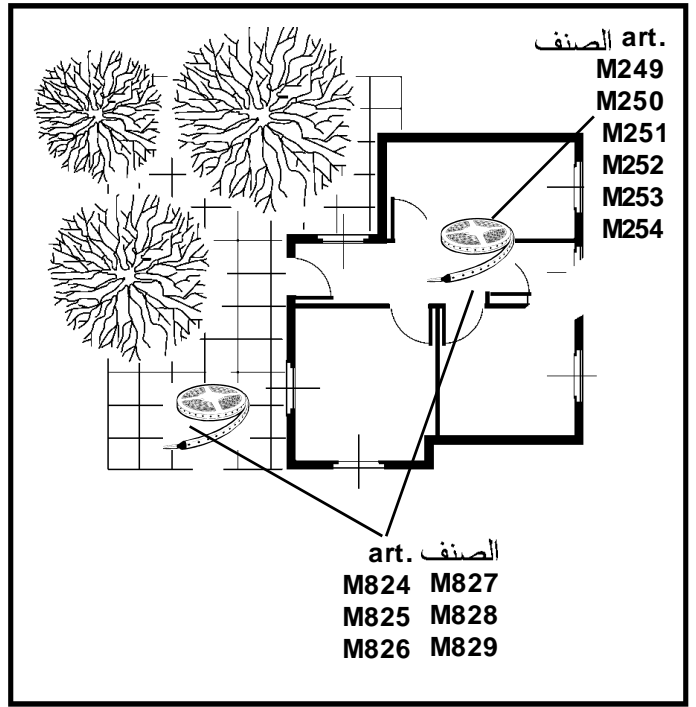
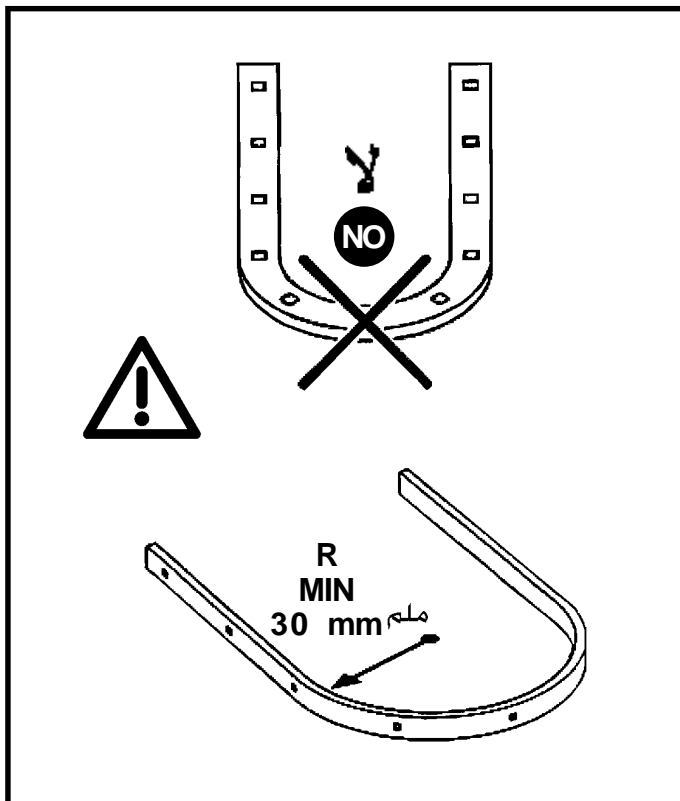
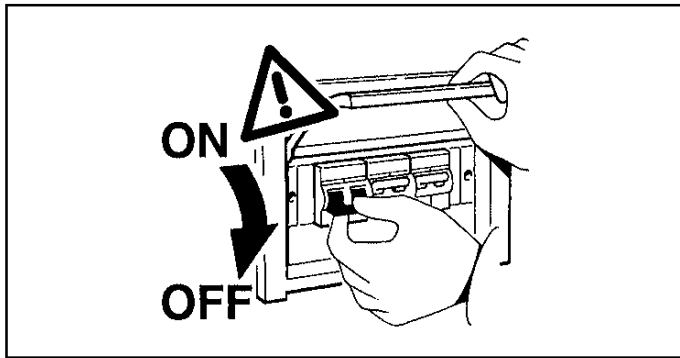

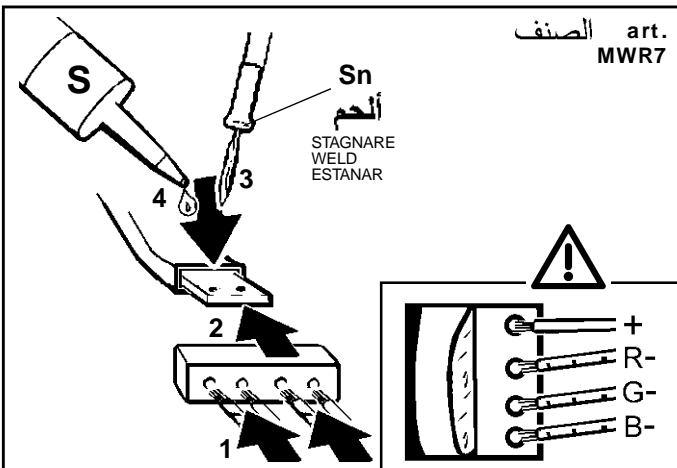
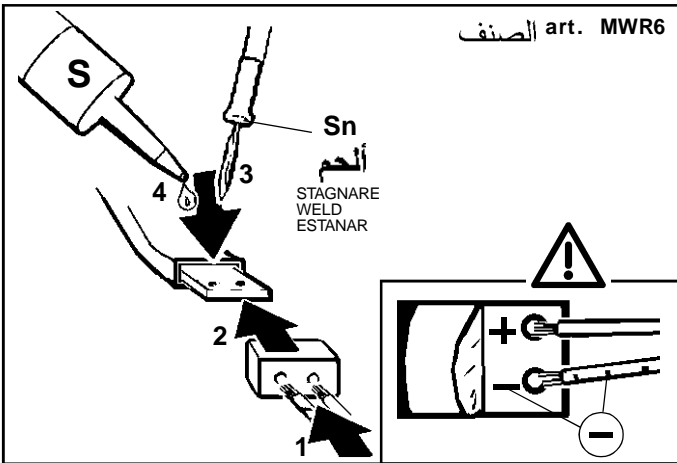
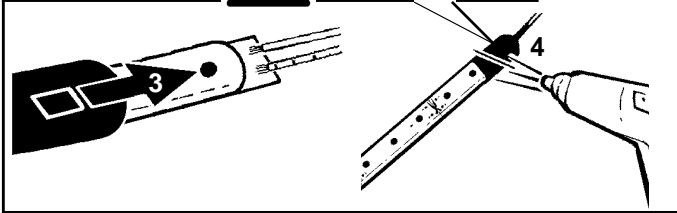
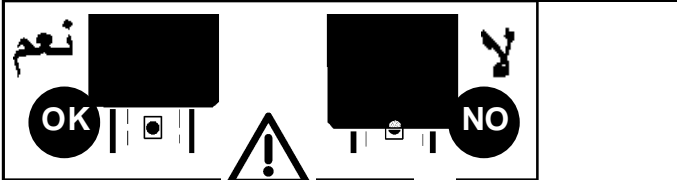
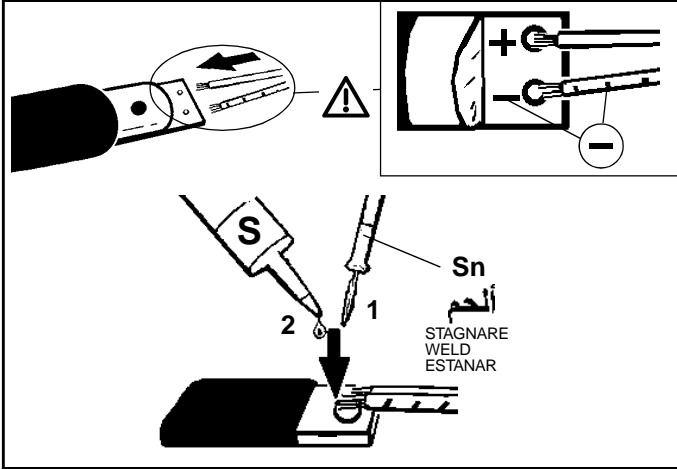
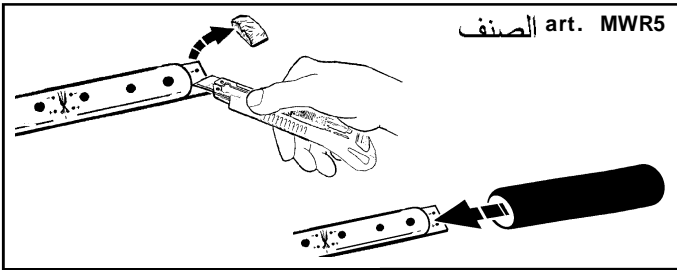

ملاحظة: درجة حماية النظام مضمونة فقط إذا تمت عملية السلكتة (معالجة بالسيليكون) بالشكل الصحيح S . عر

I N.B.: Il grado di protezione del sistema, é garantito soltanto se si effettua correttamente l'operazione di siliconatura S.

GB N.B.: The degree of protection offered by the system is only guaranteed if the siliconisation procedure is performed correctly S.

E N.B.: El grado de protección del sistema está garantizado sólo si se realiza correctamente la operación de siliconado S.

MAX m

كابح ALIMENTATORE - BALLAST - ALIMENTADOR

الصنف ART	MWF7 MZ08	MX36 MWF8 MZ09	MWF9	MWG0	MWF7 MZ08 + MWF9	MWF8 MZ09 + MWF9	MWF7 MZ08 + MWP3	MWF8 MZ09 + MWP3
M249-M250 M251-M252 M254-M824 M825-M826 M827-M828	5	10*	/	/	/	/	5	10
M253 - M829	/	/	10	10	5	10	/	/

يمكن القيام بتوصيل تسلسلي وإلى غاية 10 متر من Led Strip ضمن اللواقفة على اختلاف في الإثارة على الخط. عر

I E' possibile collegare in serie fino a 10m di Led Strip accettando delle differenze di luminosità sulla linea

GB The in-series connection of LED strips is possible up to 10 m allowing for any differences in luminosity on the line.

E Il est possible de brancher en série jusqu'à 10 mètres de "Led Strip" sous réserve d'accepter des différences de luminosité sur la ligne.

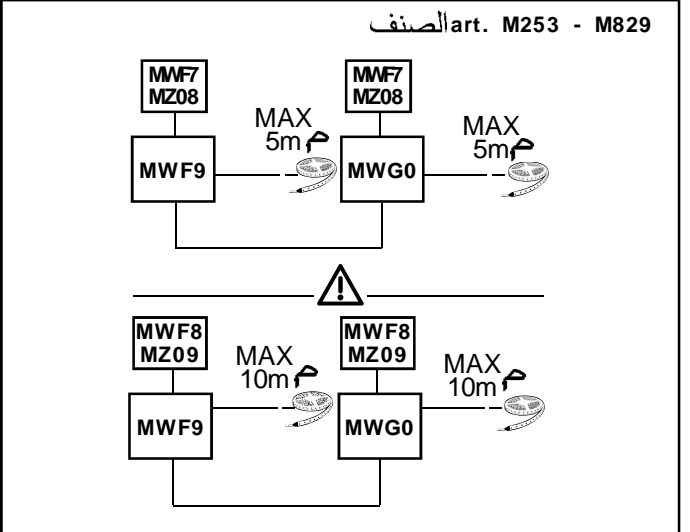

الصفحة

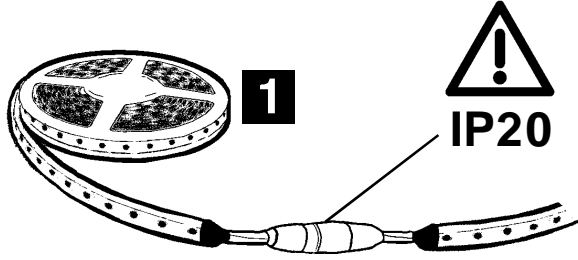

شريط يتكثّل بشكل ذاتي  
 NASTRO AUTOAGGLOMERANTE  
 SELF-VULCANISING TAPE  
 CINTA AUTOAGLOMERANTE  
 (SCOTCH 23 3M)

ART الصفحة	Ampere/m [A]
M249 - M250 M251 - M252 M254 - M824 M825 - M826 M827 - M828	0.45
M253 - M829	0.4*

\* في حالة استعماله مع واجهة MWG0 - MWF9  
 \* Se utilizzato con interfaccia MWF9 - MWG0  
 \* If used with MWF9 - MWG0 interface  
 \* Si utilizado con interfaz MWF9 - MWG0

$$L = \frac{25 \times S}{A \times m}$$

ملم  
 [mm<sup>2</sup>] = S  
 أمبير/متر = A  
 مجموع الأمتار الموصولة بالخط = M

S = Sezione cavo in Rame [mm<sup>2</sup>]  
 A = Ampere/m  
 m = Metri totali collegati alla Linea  
 S= Copper cable section [mm<sup>2</sup>]  
 A= Ampere/m  
 m= Total metres connected to the line  
 S= Sección cable de cobre [mm<sup>2</sup>]  
 A= Ampere/m  
 m= Metros totales conectados a la línea

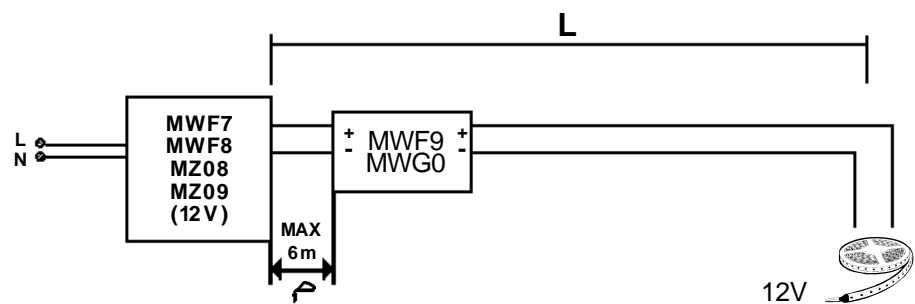
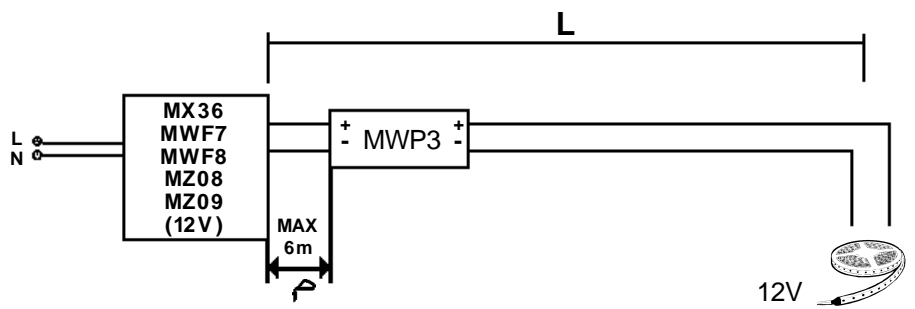
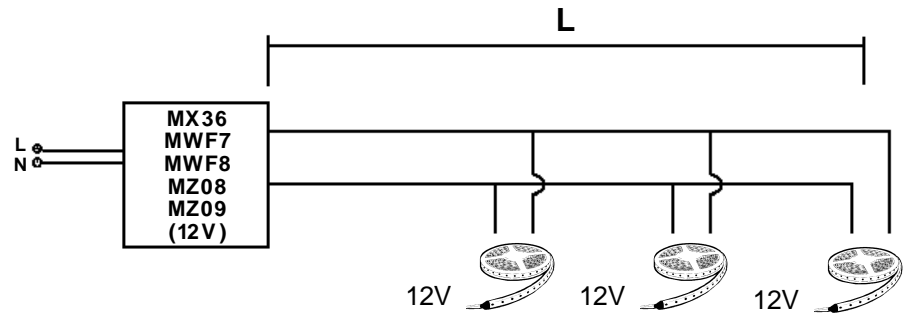
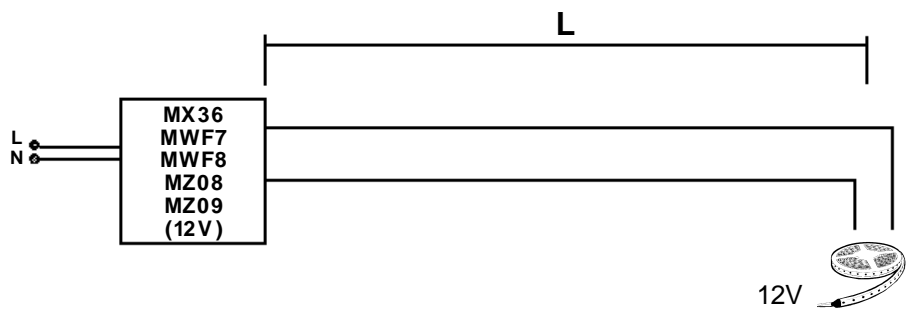



الصف art. MWF7 - MWF8 - MWP3  
MZ08 - MZ09

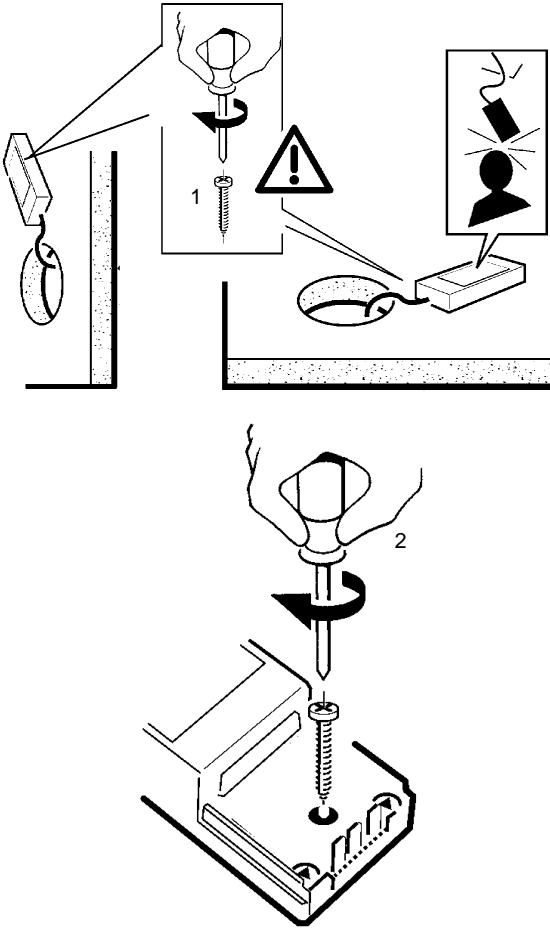

الصف art MWF9 - MWG0

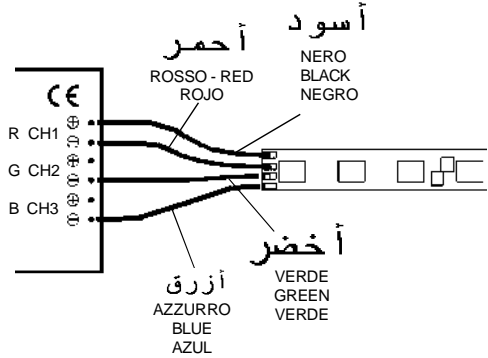

يتم ضمان عمل وسلامة الجهاز فقط إذا كان تردد التيار يعادل  $\pm 5\%$  مقارنة مع القيمة الاسمية.  
يتم ضمان التوافق، فقط إذا كانت كوابح iGuzzini (سلعة رقم MWF7/MWF8/MZ08/MZ09) أو ما يشابهها من نوع SELV متوافقة مع النظم السائدة والمحددة من قبل مجموعة الدول الأوروبية.

I Le prestazioni e la sicurezza dell'apparecchio sono garantite soltanto per oscillazioni della corrente del  $\pm 5\%$  rispetto al valore nominale.  
La conformità alla norma è garantita soltanto utilizzando alimentatori iGuzzini (art.: MWF7/MWF8/MZ08/MZ09) od equivalenti di tipo SELV che rispondano alle vigenti norme C.E.I.

GB The performance level and safety of the lighting fixture are only guaranteed for oscillations of  $\pm 5\%$  in the current, in relation to the nominal value.  
Conformity with the standard is guaranteed only if either iGuzzini ballasts (item code MWF7/MWF8/MZ08/MZ09) or equivalent SELV type ballasts which comply with current C.E.I. regulations are used.

E Las prestaciones y la seguridad del aparato están garantizada solamente con oscilaciones de la corriente del  $\pm 5\%$  respecto al valor nominal.  
La conformidad a la norma se garantiza solamente con el uso de alimentadores iGuzzini (art. MWF7/MWF8/MZ08/MZ09) o equivalentes de tipo SELV que cumplen las normas vigentes C.E.I.

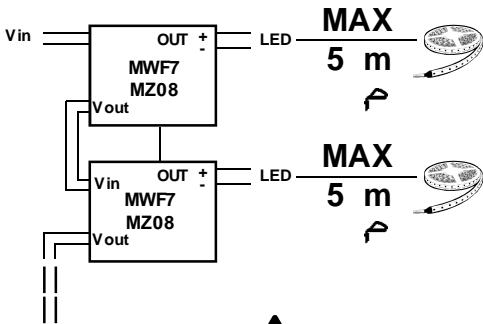

DALI

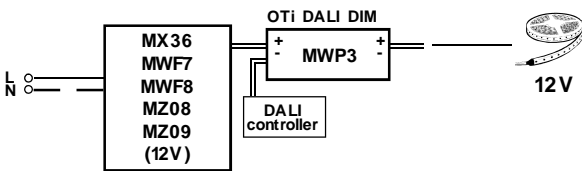

TOUCH DIM

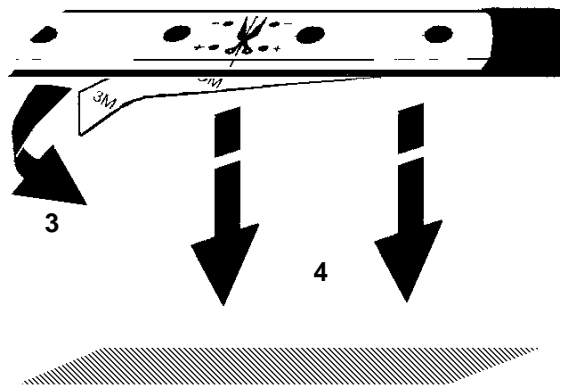
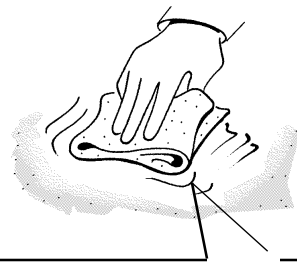
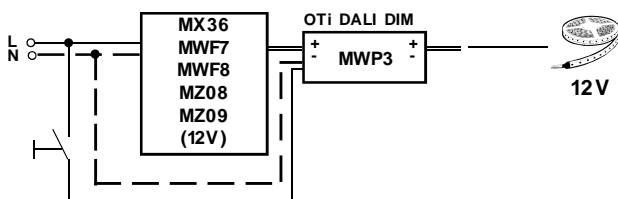

## تركيب الملحقات

INSTALLAZIONE DEGLI ACCESSORI  
INSTALLING THE ACCESSORIES  
INSTALACION DE ACCESORIOS

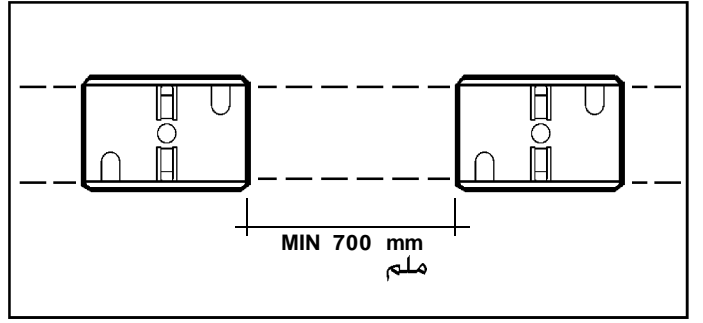
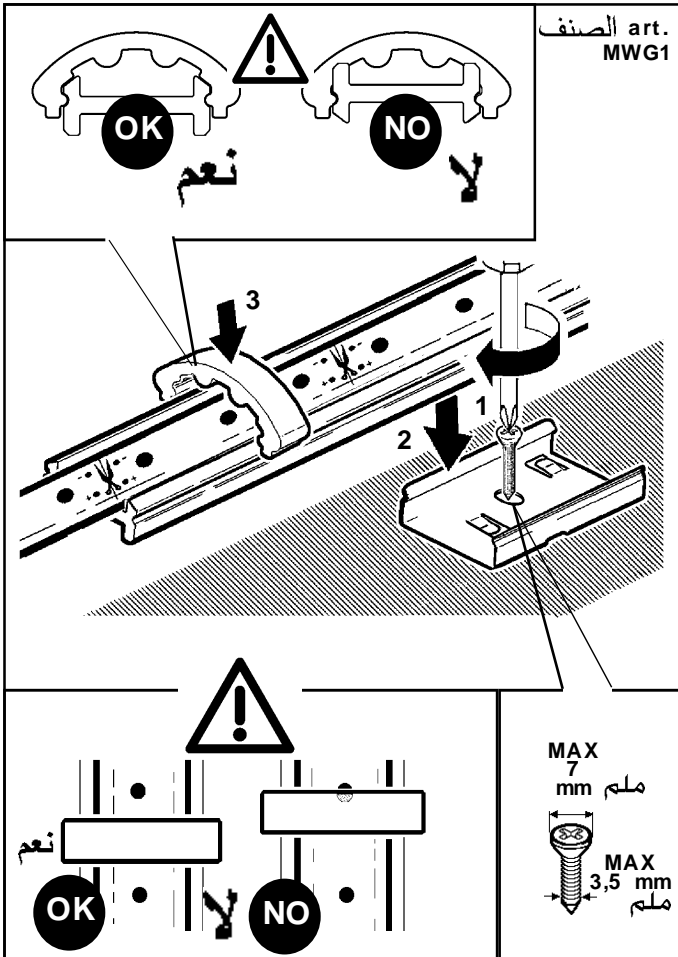
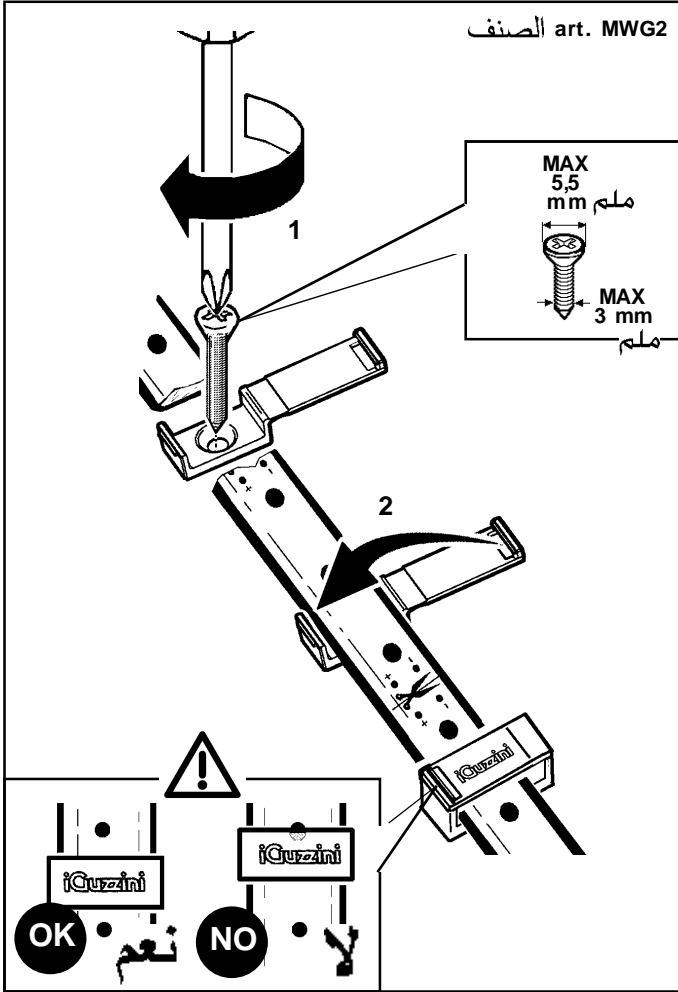

## استبدال الضوء LED

SOSTITUZIONE DEL LED  
REPLACING THE LED  
REEMPLAZO DEL LED

تنبيه: لاستبدال الضوء LED اتصل بشركة iGuzzini .

I N.B.: Per la sostituzione del LED contattare l'azienda iGuzzini.

GB N.B.: For information on LED replacement please contact iGuzzini.

E NOTA: Para sustituir el LED llame a la empresa iGuzzini.

## لمحة إكسسوارات

ACCESSORI PROFILI  
PROFILES ACCESSORIES  
ACCESORIOS PERFILES

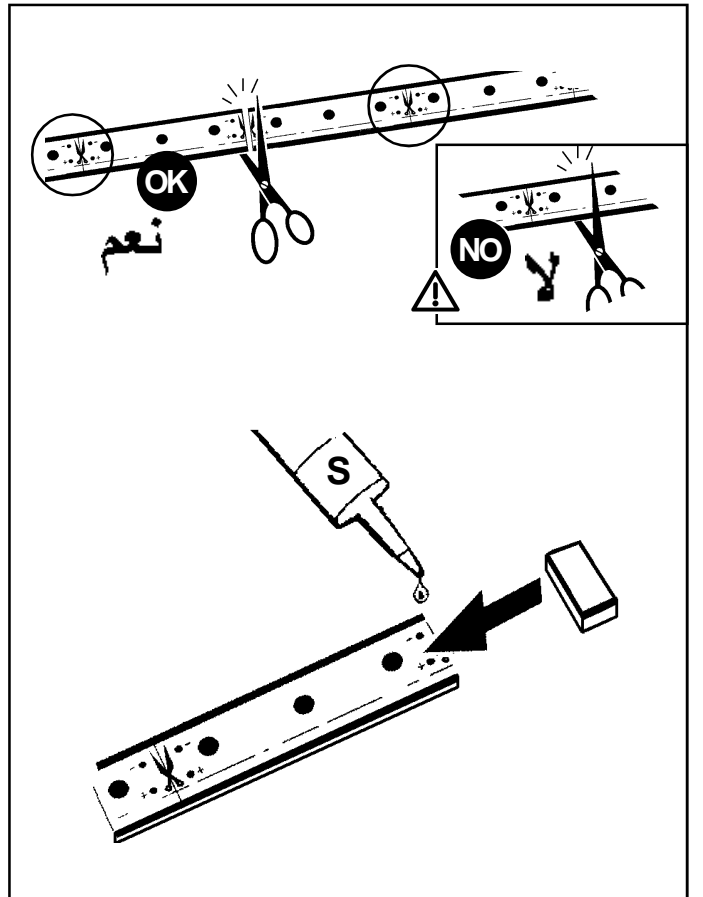

MWR6 + (M824 - M826  
M827 - M828)

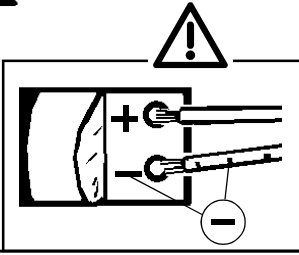
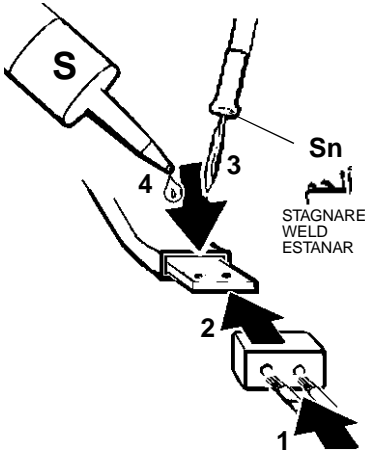

MWR5 + (M249 - M250  
M251 - M252)

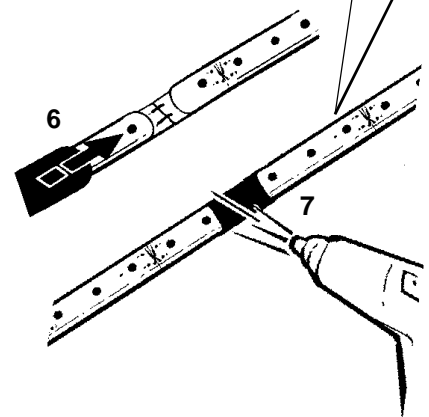
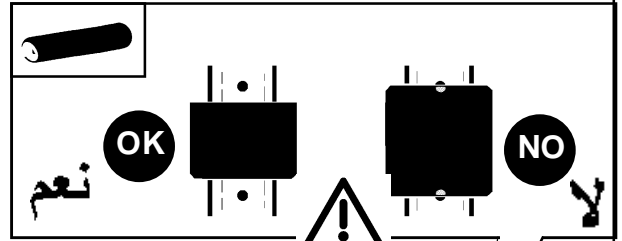
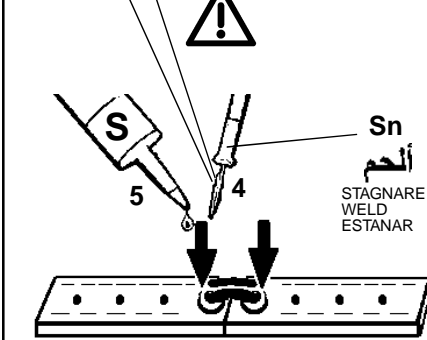
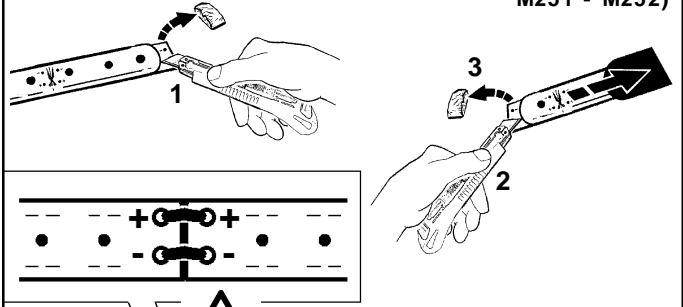

MWR6 + (M249 - M250  
M251 - M252)

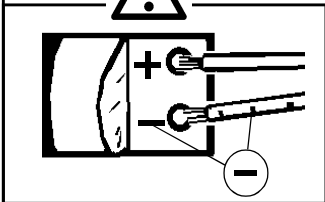
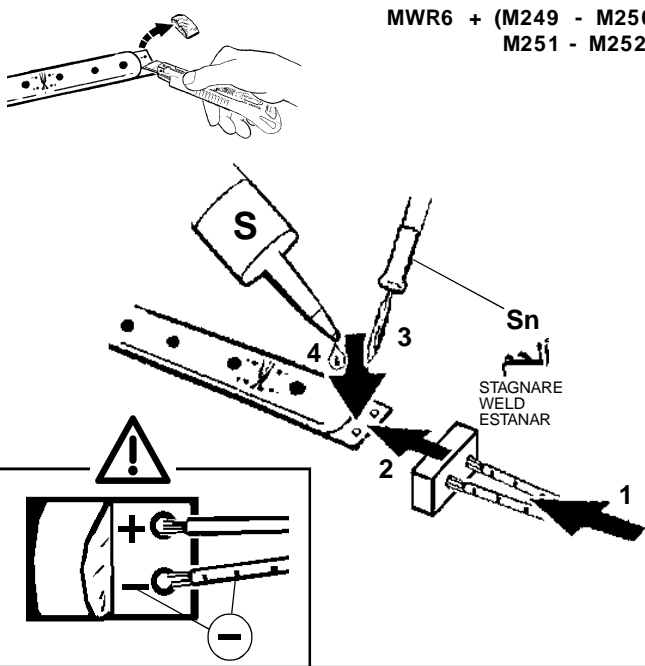

MWR7 + (M253)

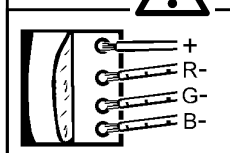
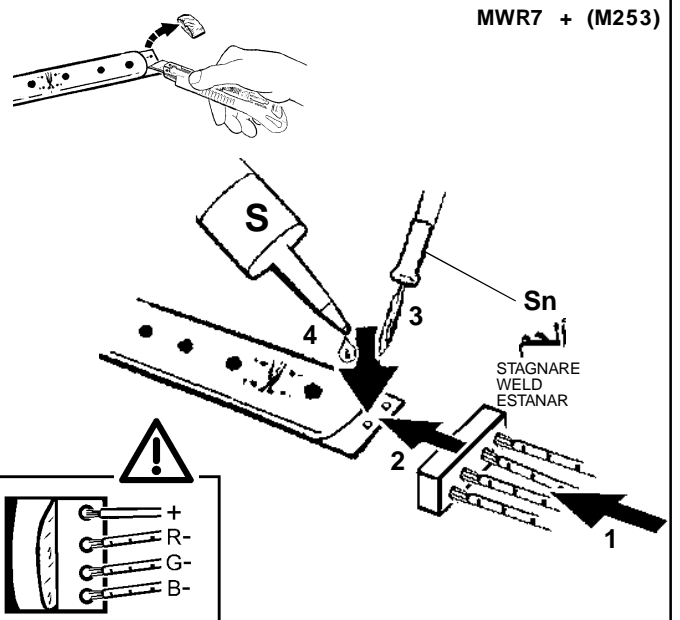

MWR5 + (M253)

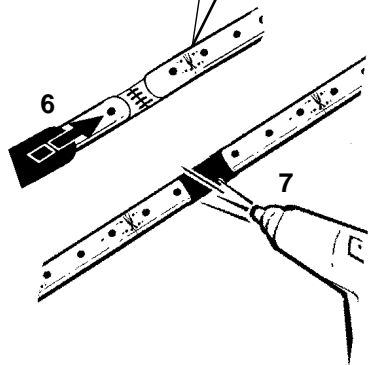
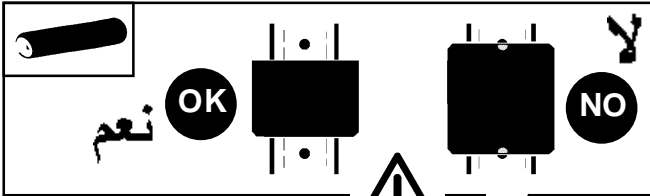
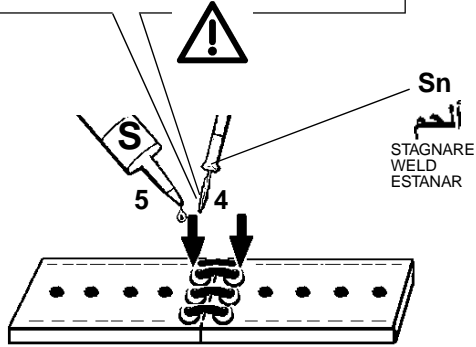
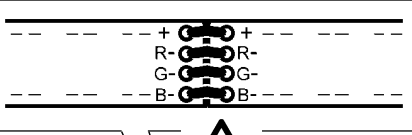
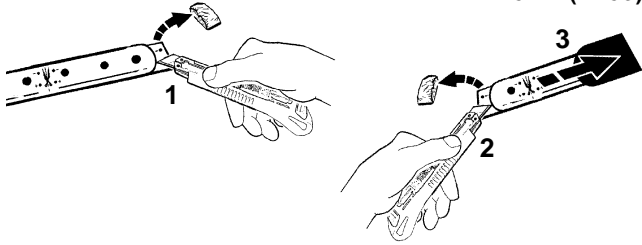

ملاحظة: درجة حماية النظام مضمونة فقط إذا تمت عملية السلكتة (معالجة بالسيليكون) بالشكل الصحيح S . عر

I N.B.: Il grado di protezione del sistema, é garantito soltanto se si effettua correttamente l'operazione di siliconatura S.

GB N.B.: The degree of protection offered by the system is only guaranteed if the siliconisation procedure is performed correctly S.

E N.B.: El grado de protección del sistema está garantizado sólo si se realiza correctamente la operación de siliconado S.

الصف art. M824 - M826

M827 - M828

Sn  
ألمع  
STAGNARE  
WELD  
ESTANAR

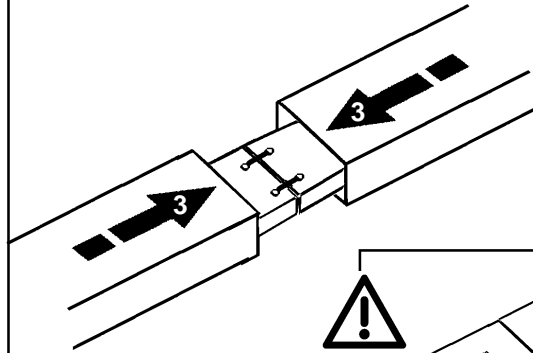
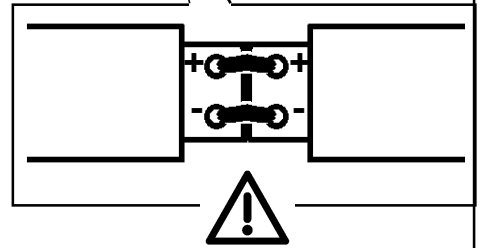
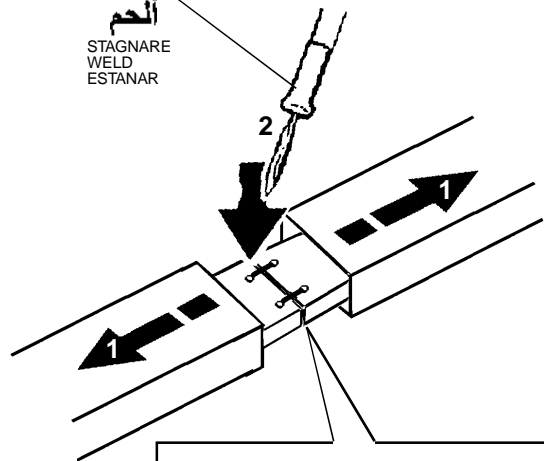

ملحوظة هامة: بتنفيذ تلك العملية لا يمكن ضمان مستوى الحماية. عر

I N.B.: Con questa operazione non viene più garantito il grado di protezione

GB N.B.: The protection degree is no longer guaranteed after this operation.

E N.B.: Con esta operación no se garantiza el grado de protección.

الصف ART

الملم  
A (mm)

MXK3 - MXK4 - MXK6 -MXK7

MXK8 - MXK9 - MXL0 - MXL1

MXL2 - MXL3 - MXQ3

12

MXK5 - MXN8 - MXQ4 - MXQ5

2

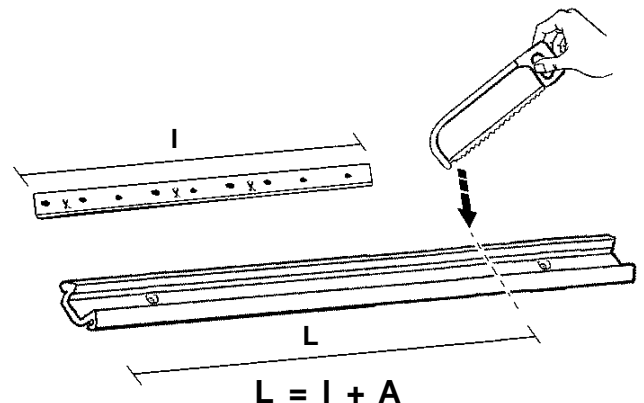

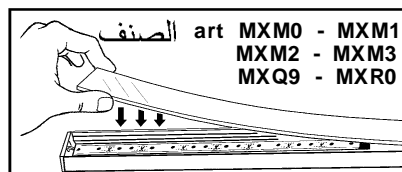
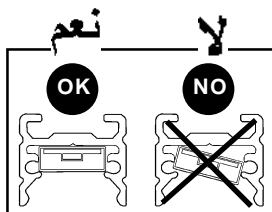
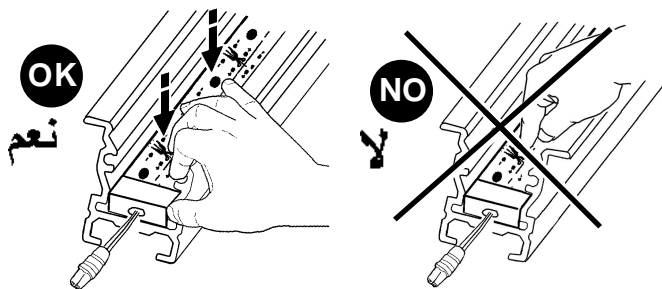
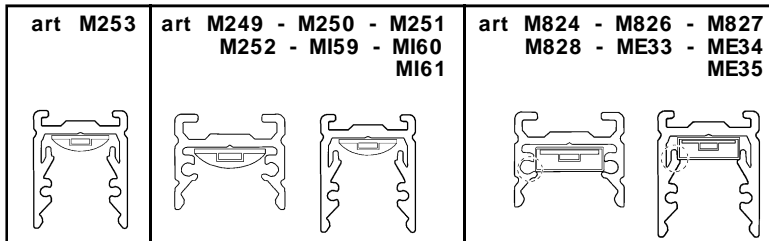
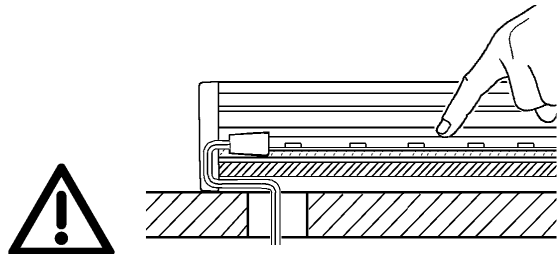
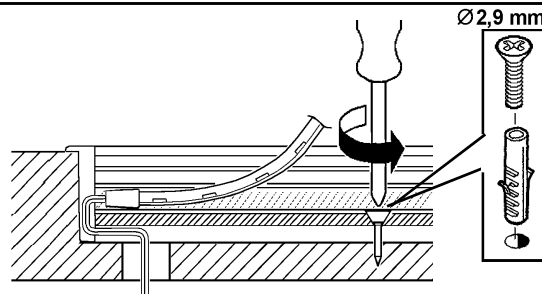
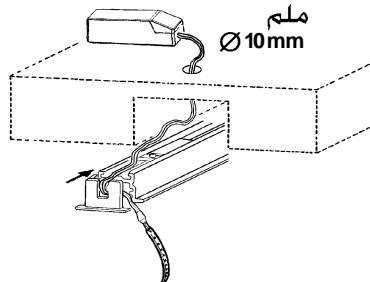
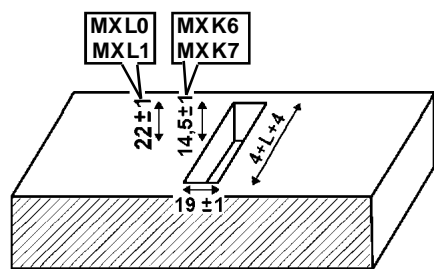
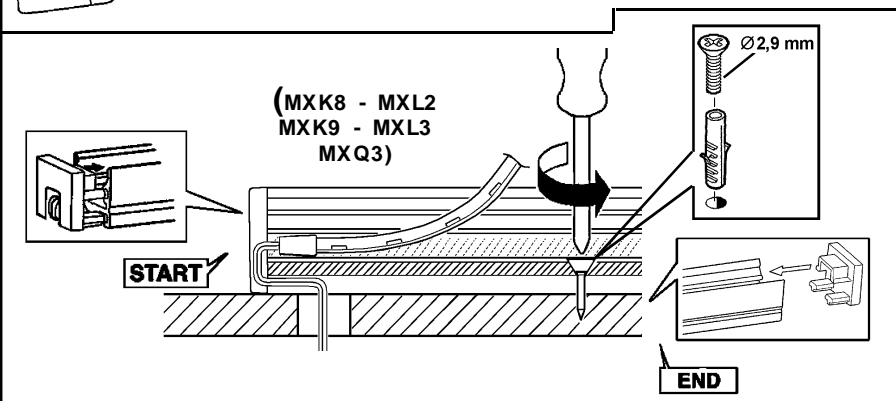
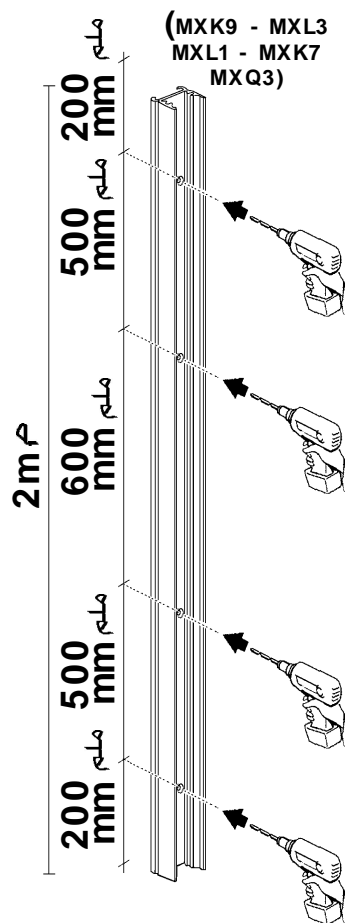
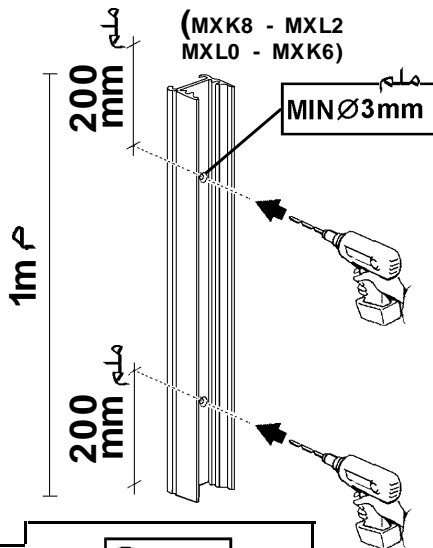
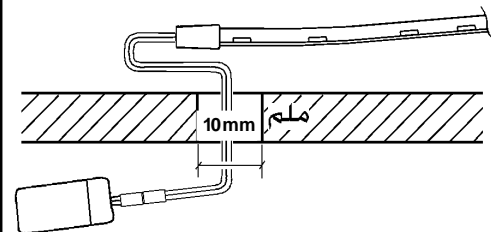
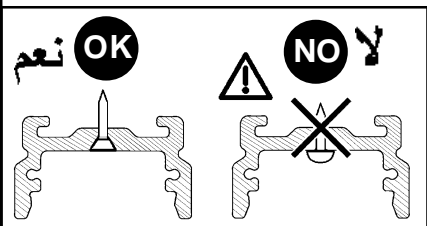
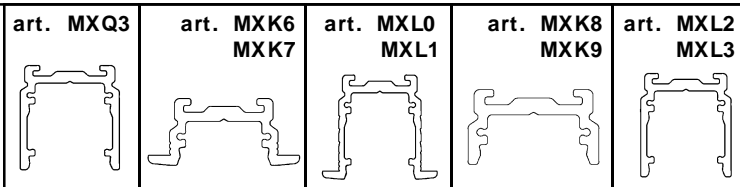

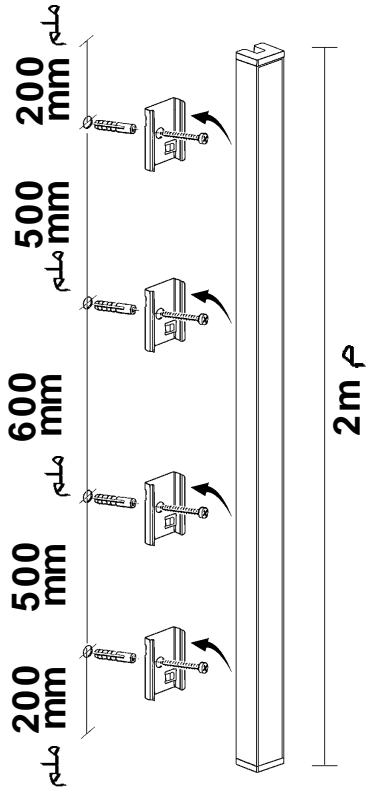
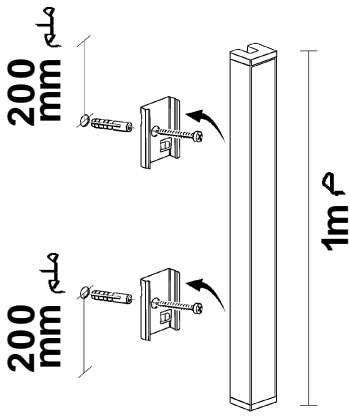
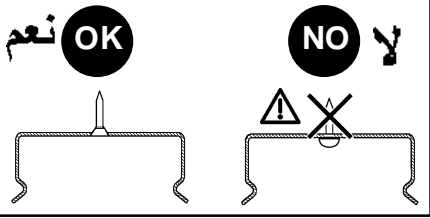

الصف

art. MXM4

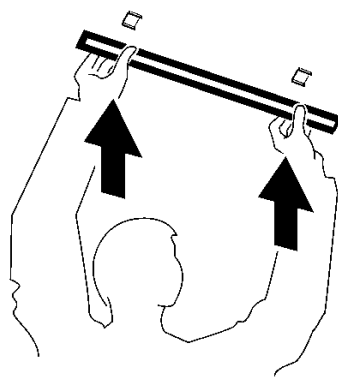
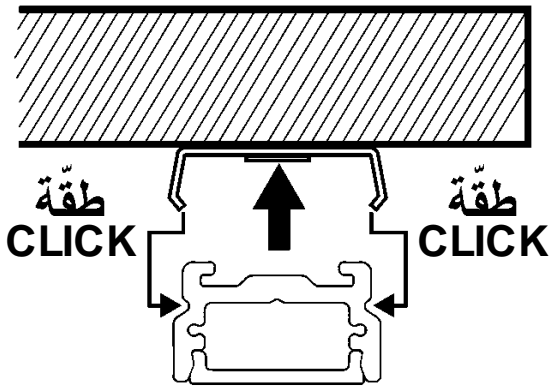
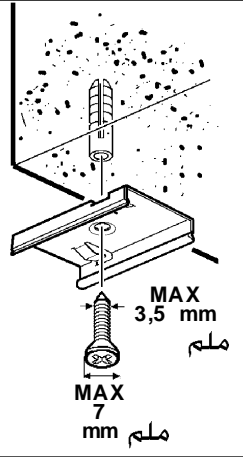

الصفحة art. MXK3  
MXK4

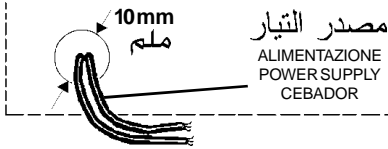
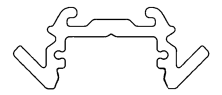

(MXK4)

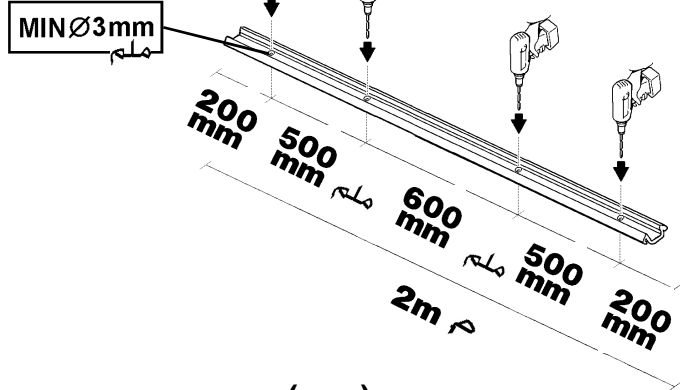

(MXK3)

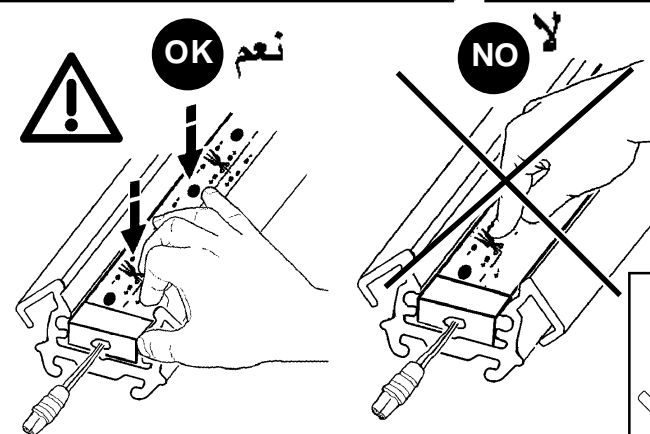
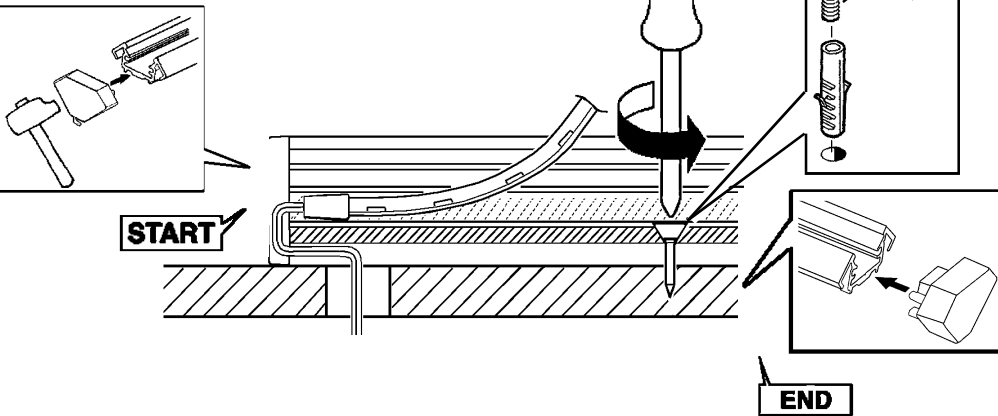
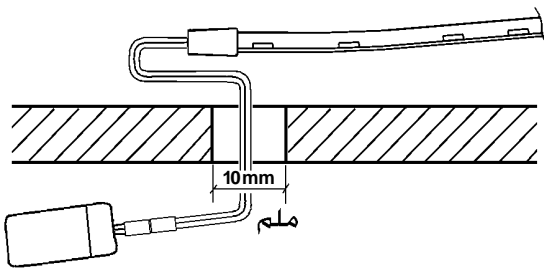
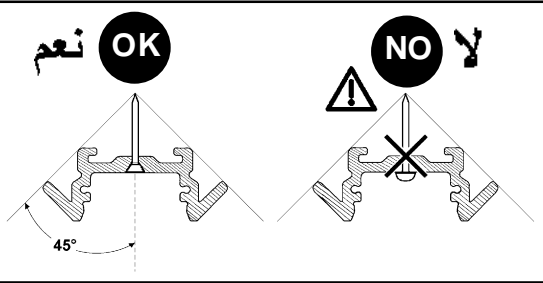
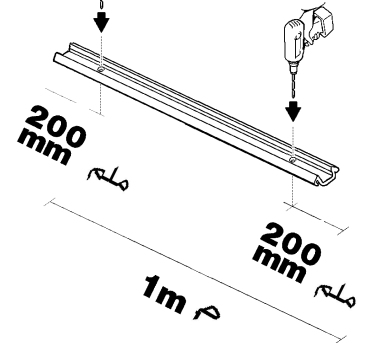

art M249 - M250 - M251  
M252 - MI59 - MI60  
MI61

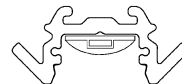

art M824 - M826 - M827  
M828 - ME33 - ME34  
ME35

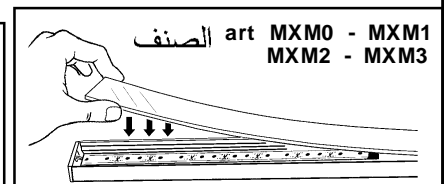
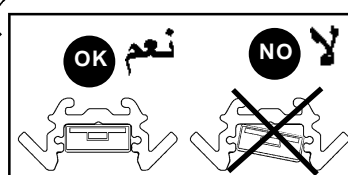
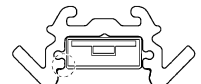

(MXK4)

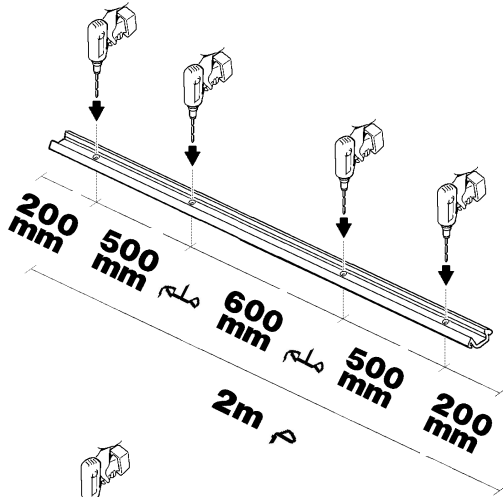

(MXK3)

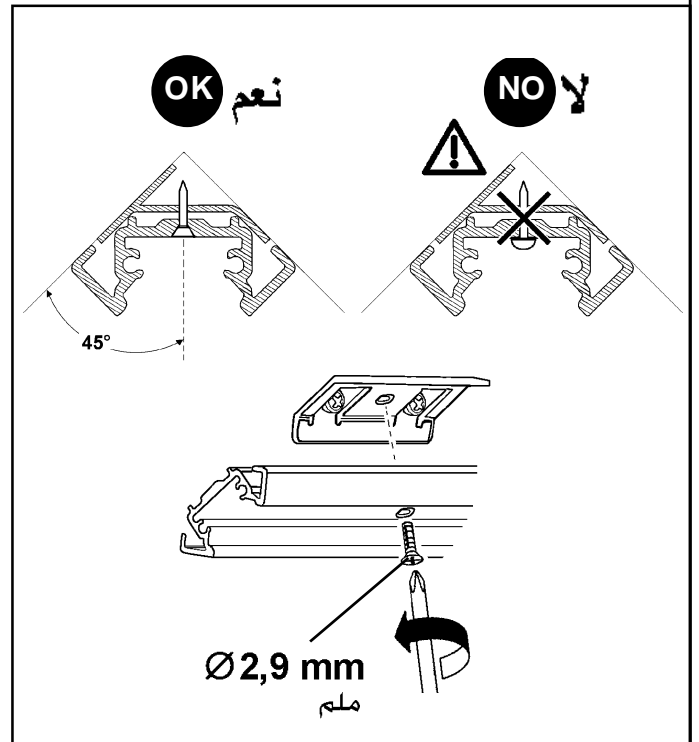
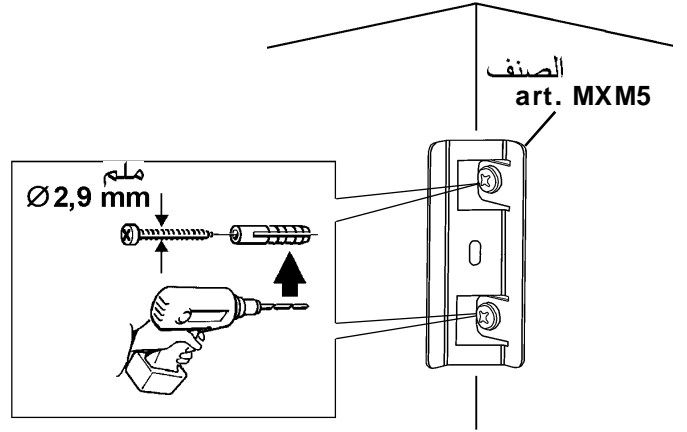
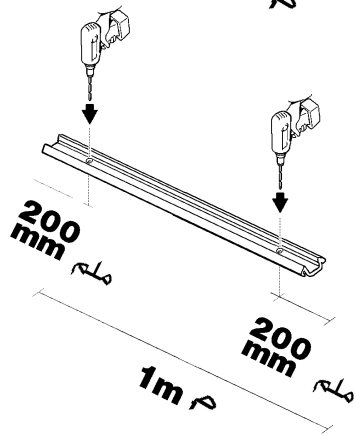



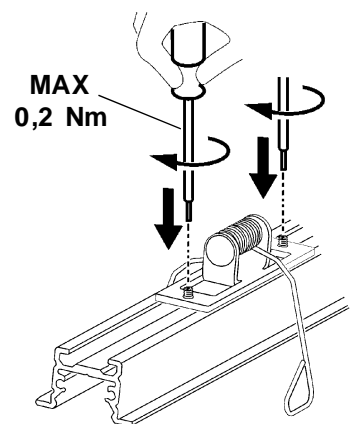
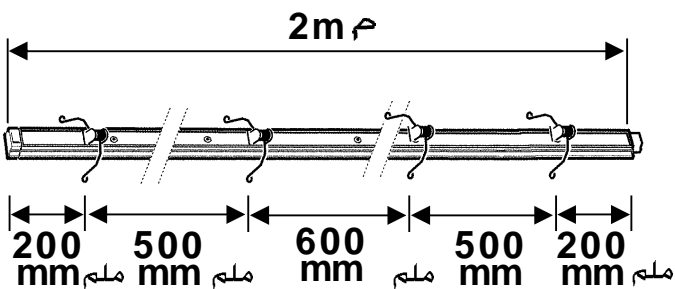
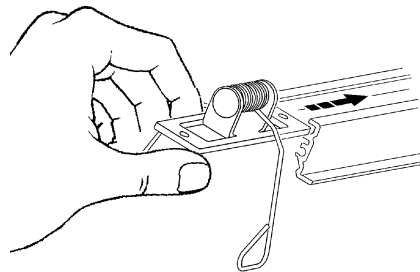
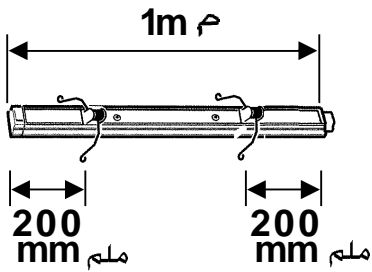
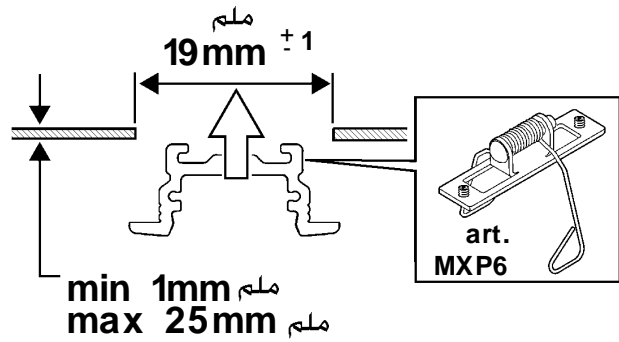
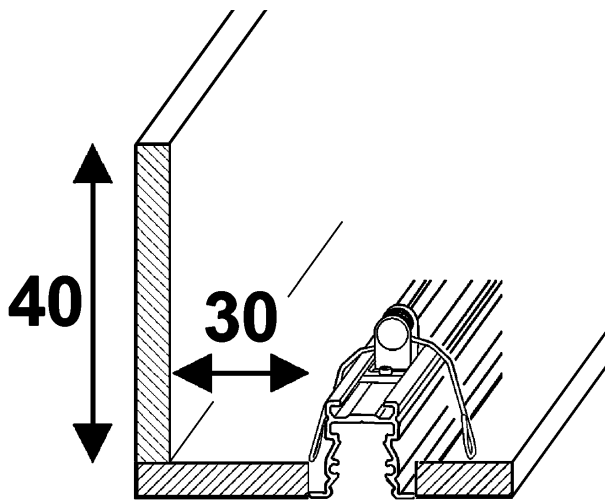
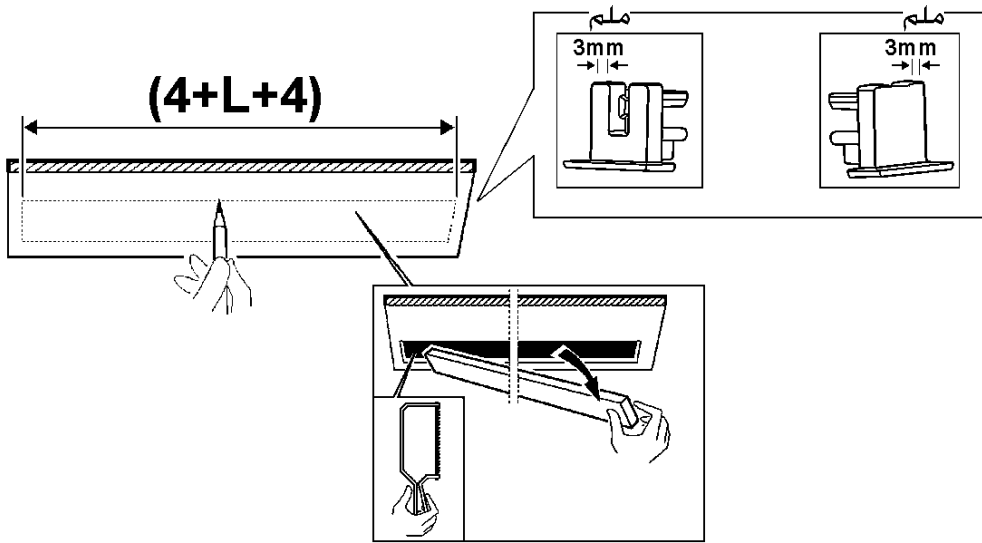
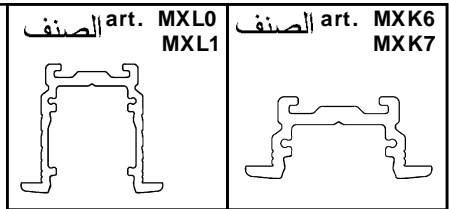

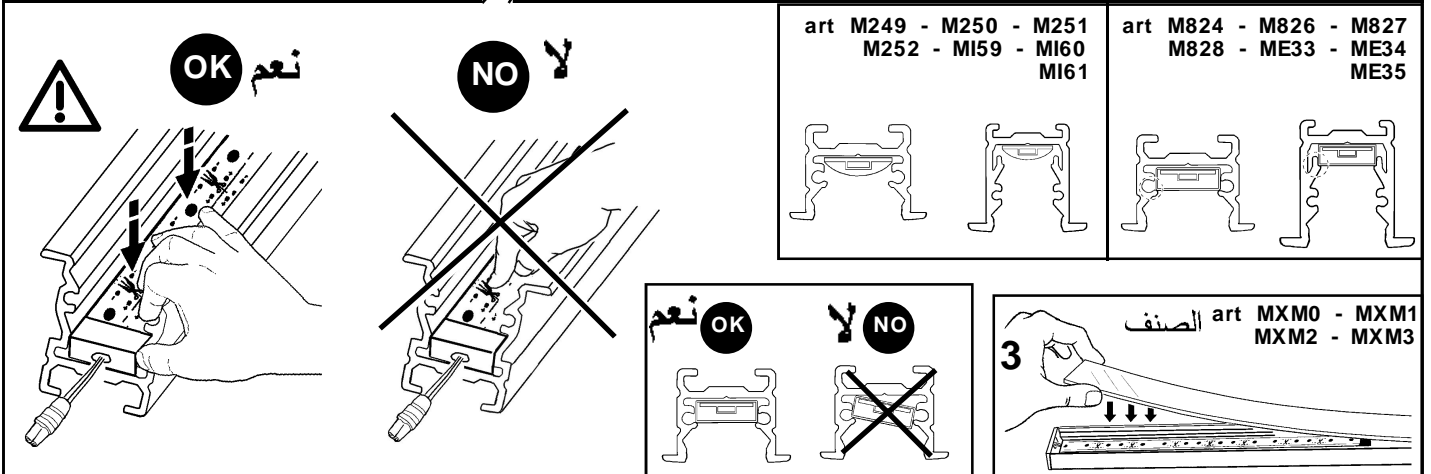
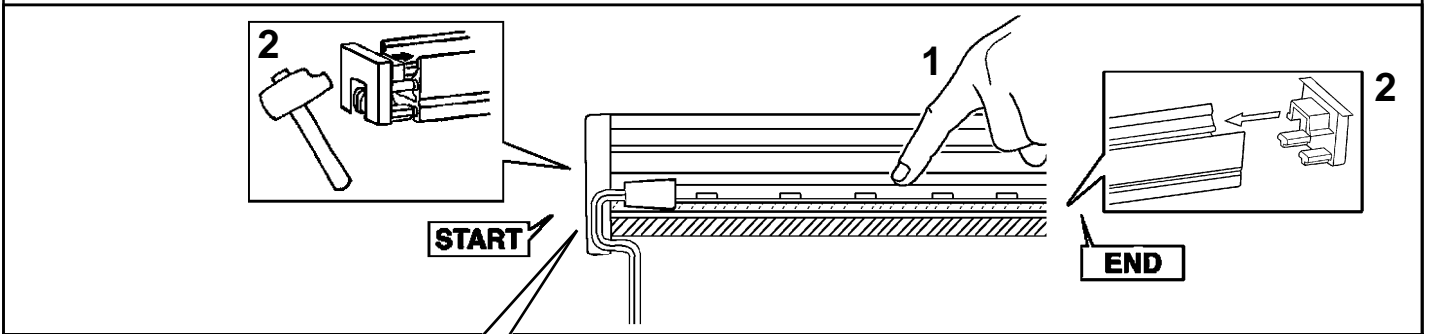
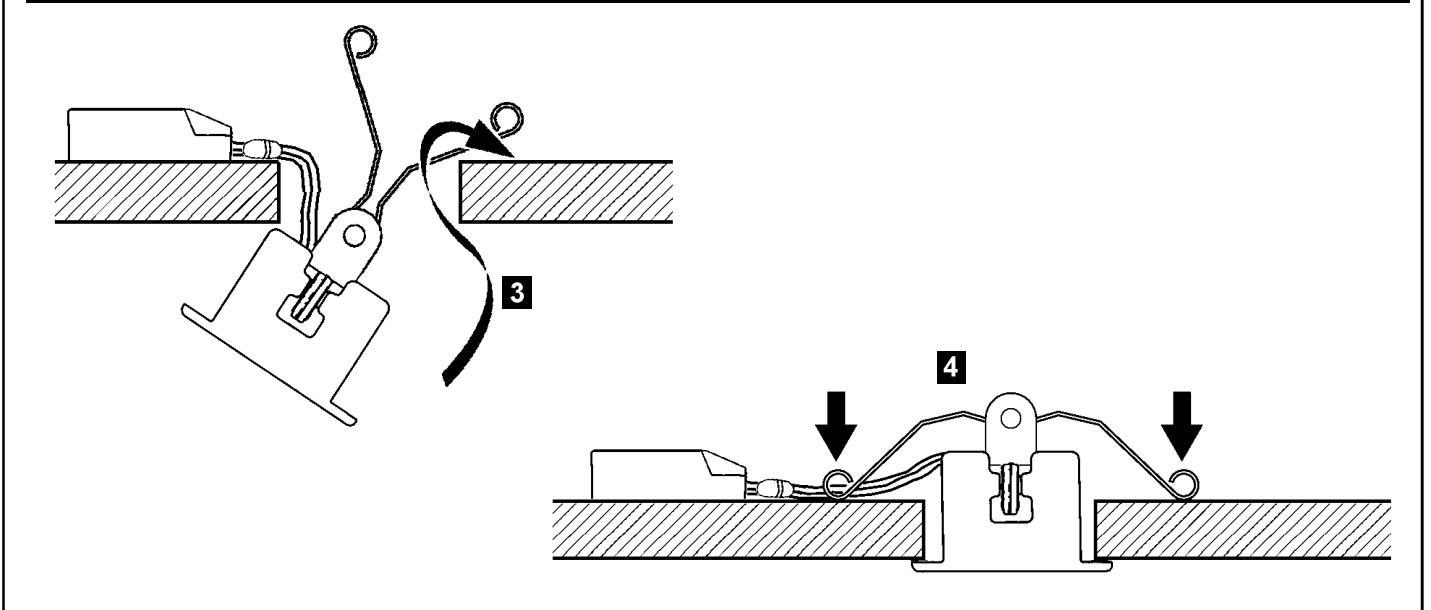
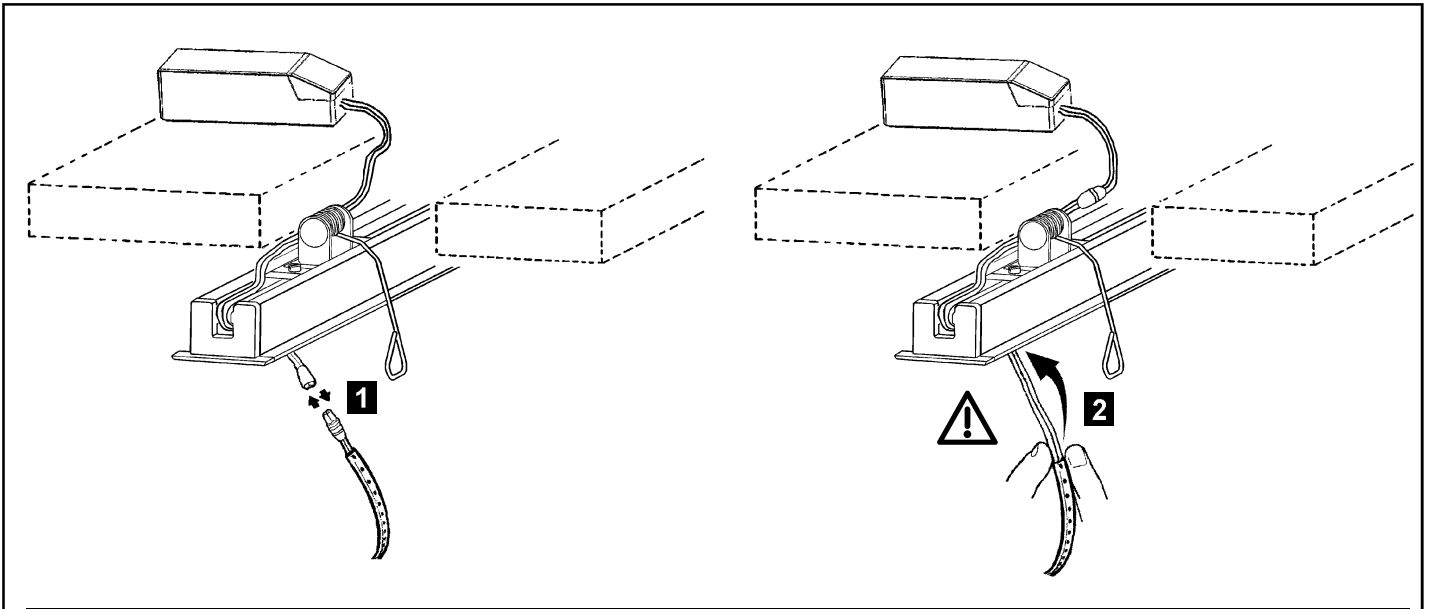

الصفحة art. MXN8

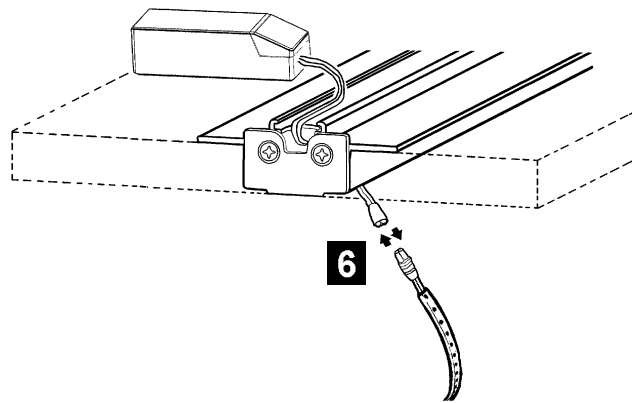
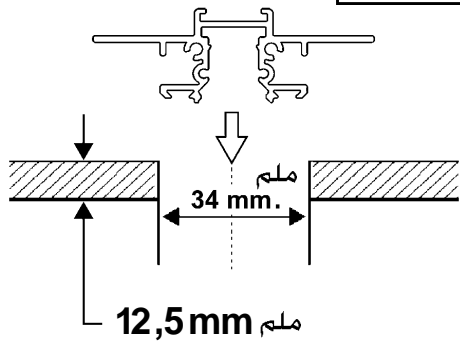

6

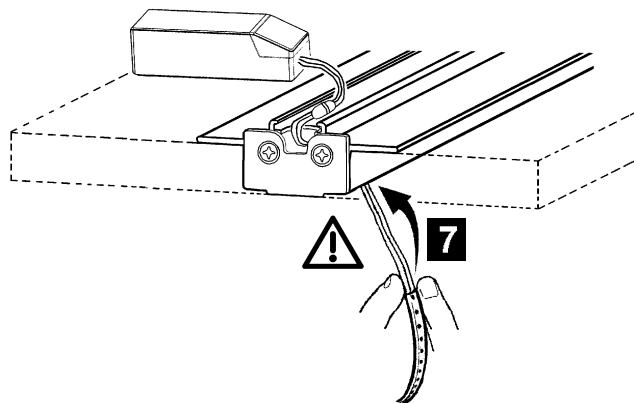

7

art M249 - M250 - M251  
M252 - MI59 - MI60  
MI61

art M824 - M826 - M827  
M828 - ME33 - ME34  
ME35

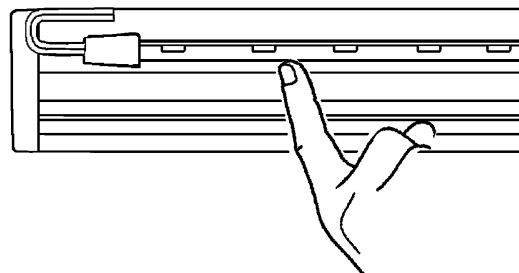
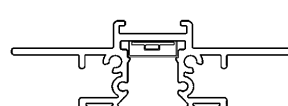
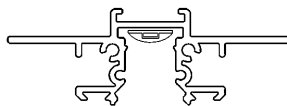

OK نعم

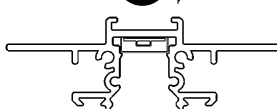

NO لا

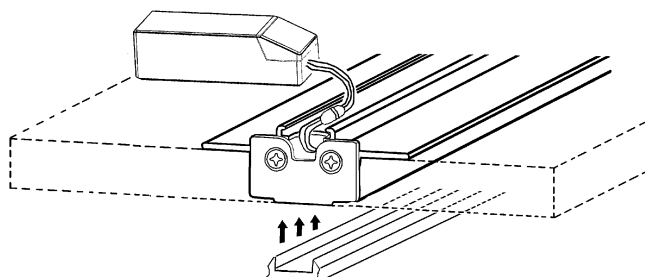

↑↑↑



(3+L+3)

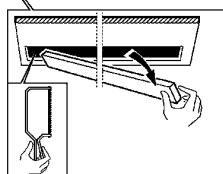
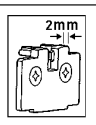
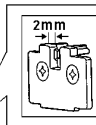
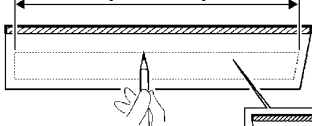

2

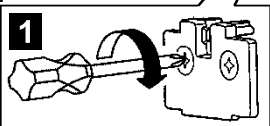

1

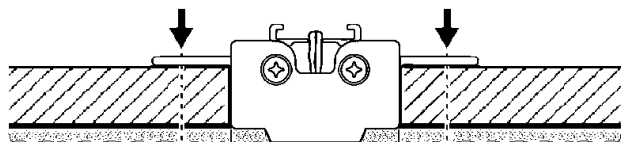

8mm ملم

3

8mm ملم

3



4



5

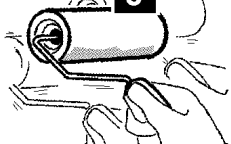

الصنف art. MXQ4

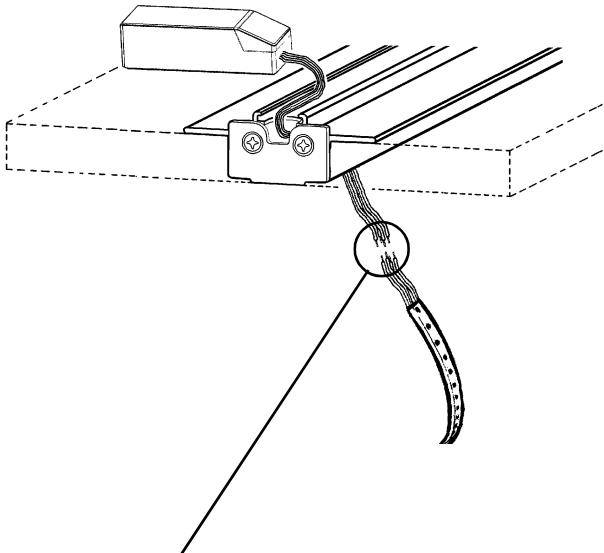
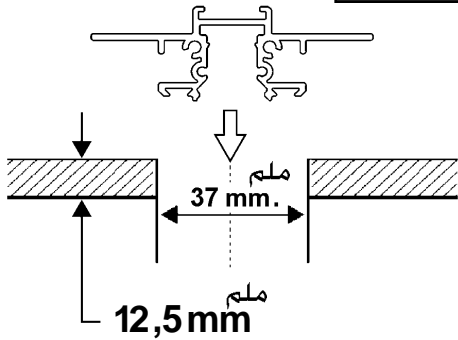

(3+L+3)

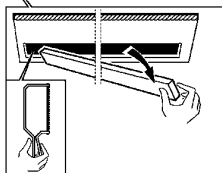
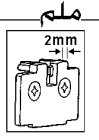
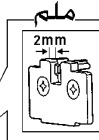
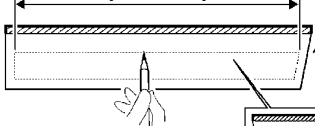

2

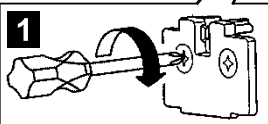

1

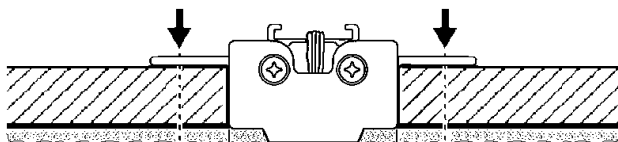

8mm

8mm

3

3



4

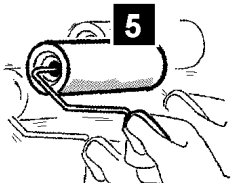

5

Sn  
أنح  
STAGNARE  
WELD  
ESTANAR

6

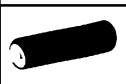
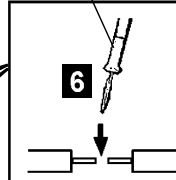
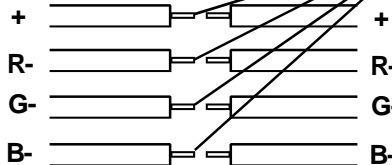

7

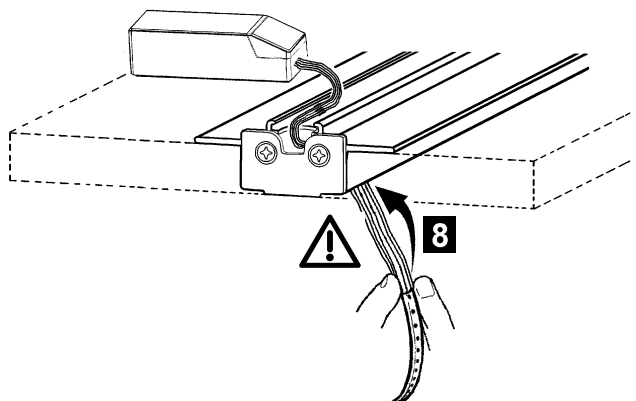
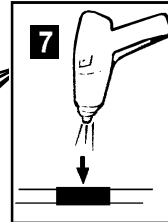

8

الصف art M253

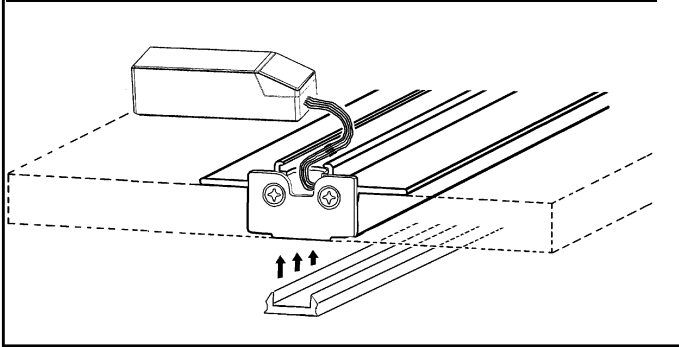
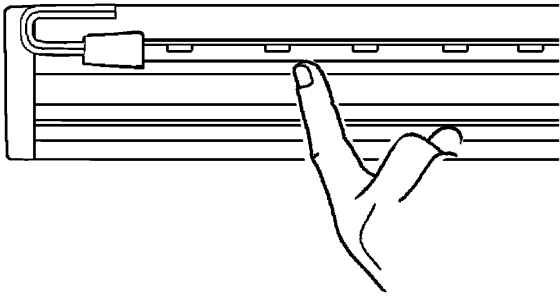
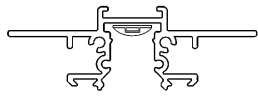

art. MXK5

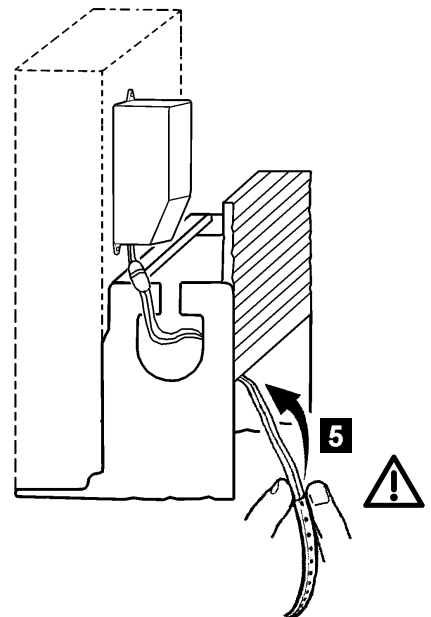
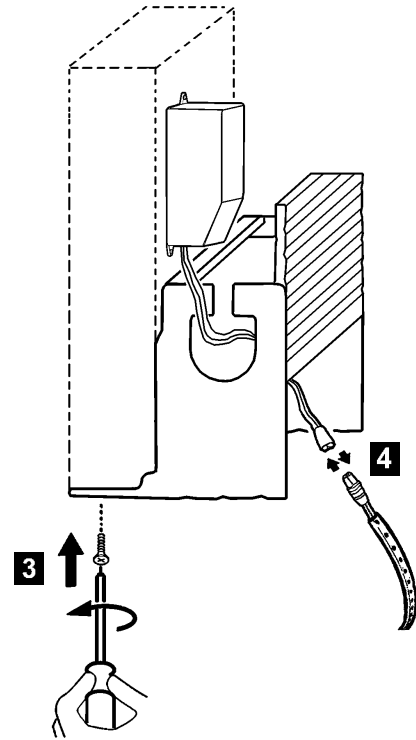
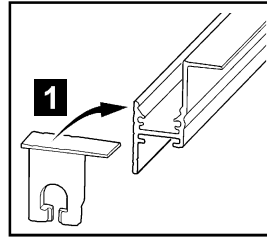
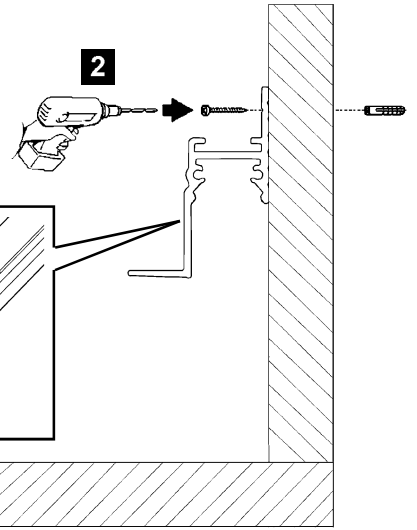
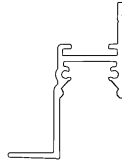

art. MXK5

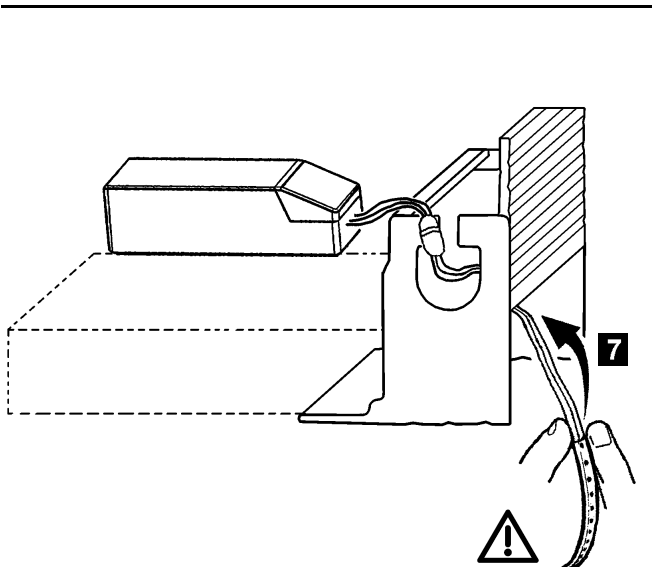
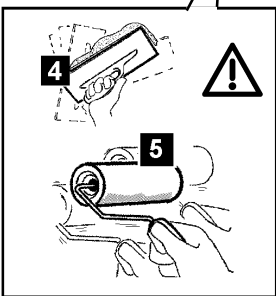
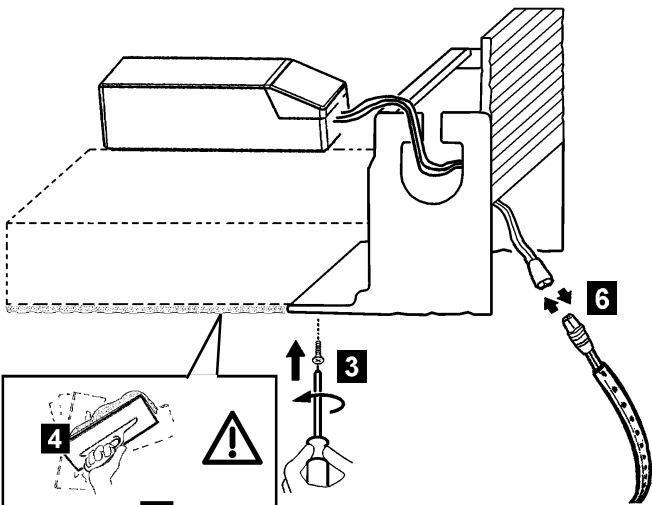
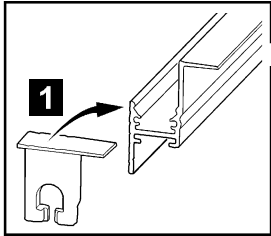
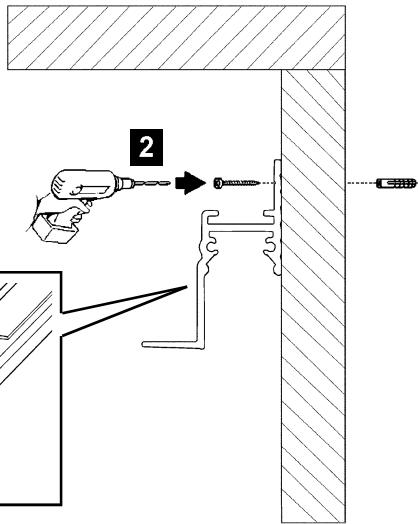
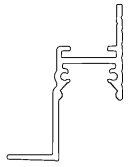

art M249 - M250 - M251  
M252 - MI59 - MI60  
MI61

art M824 - M826 - M827  
M828 - ME33 - ME34  
ME35

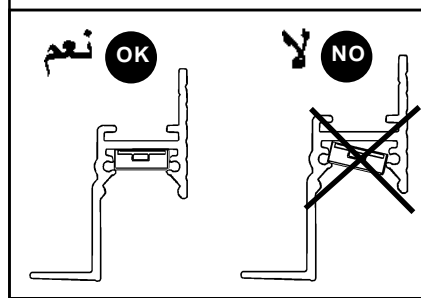
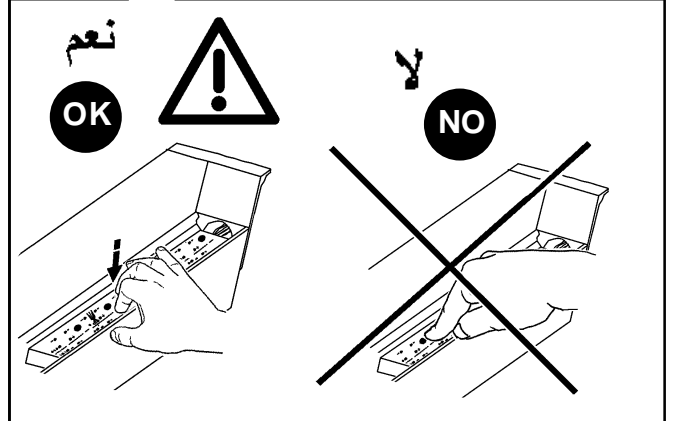
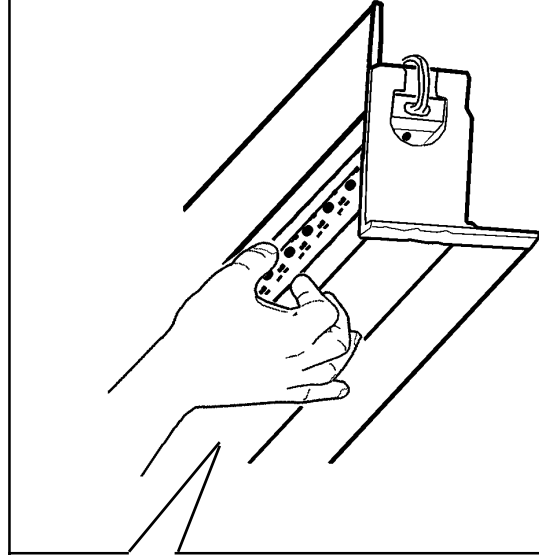
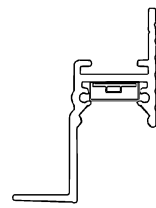
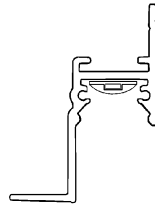

الاصنف art MXM0 - MXM1  
MXM2 - MXM3

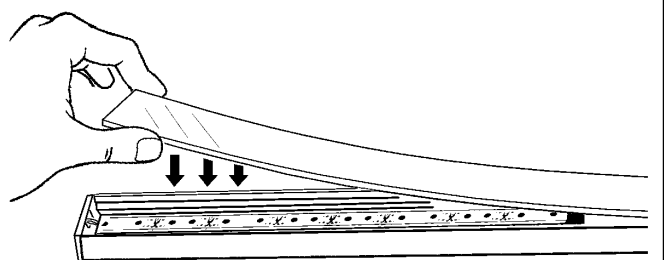

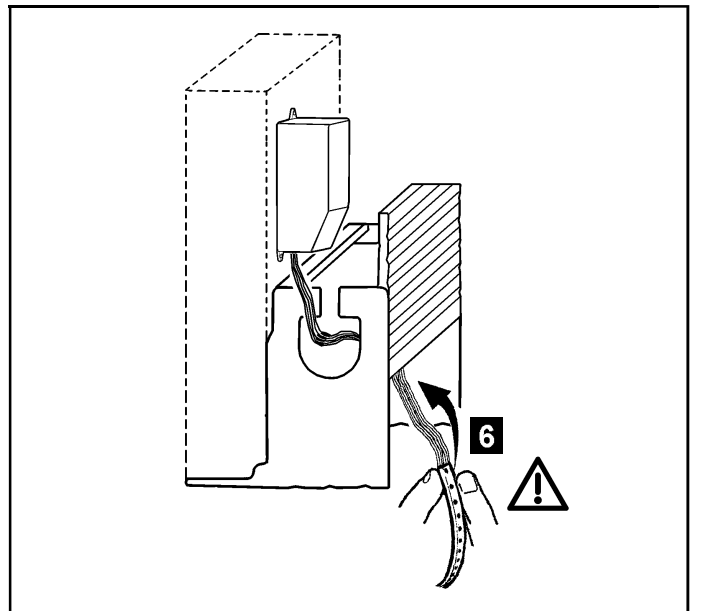
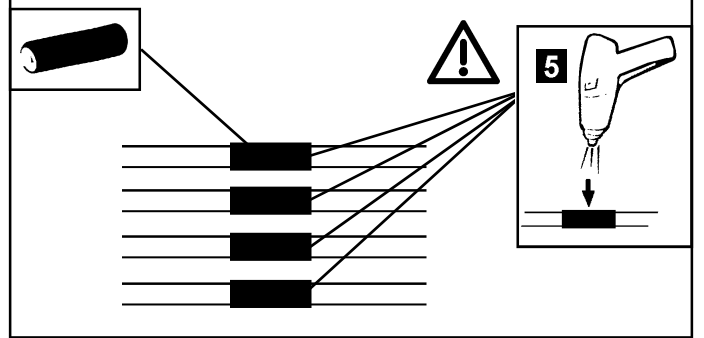
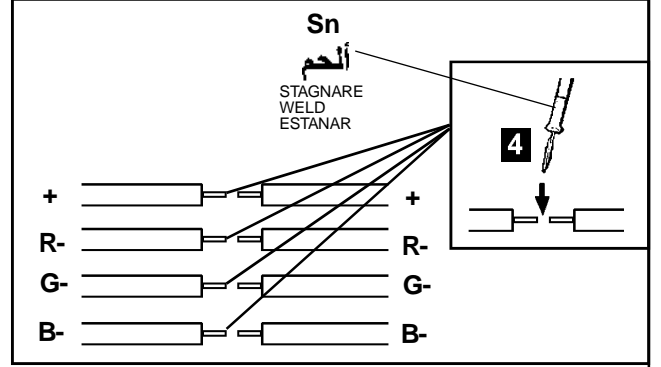
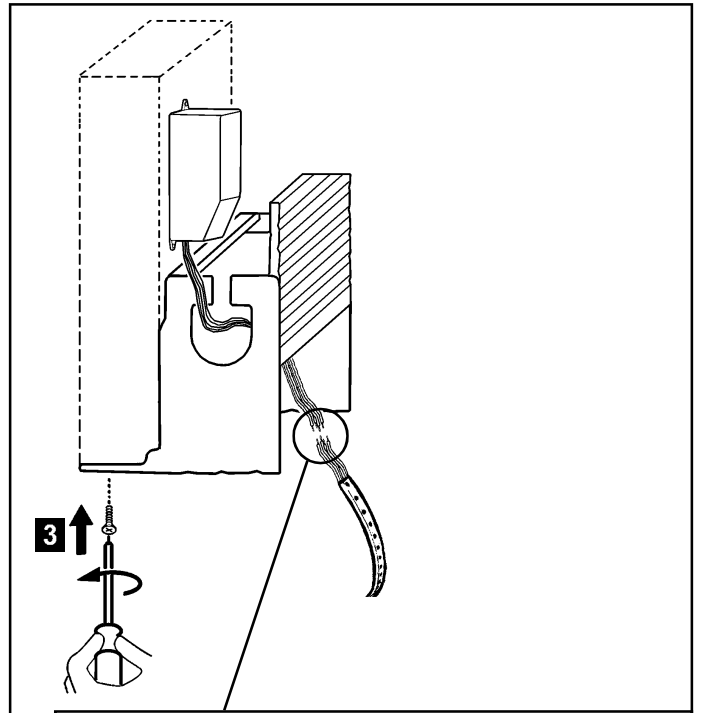
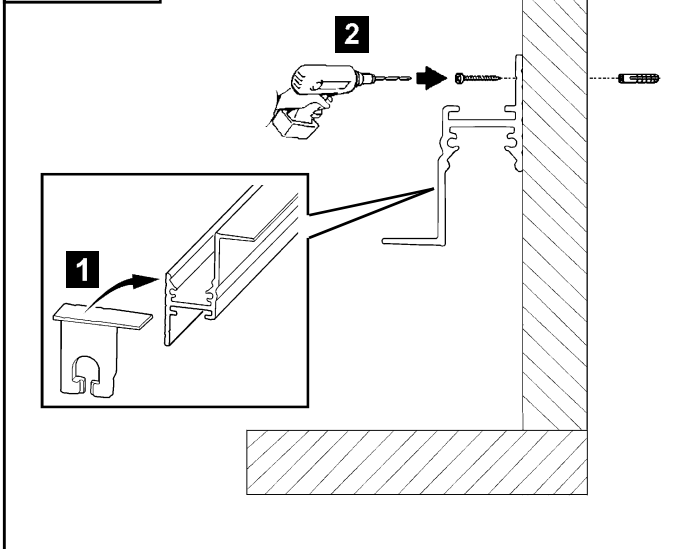
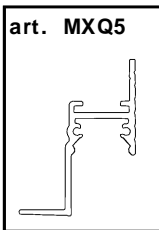
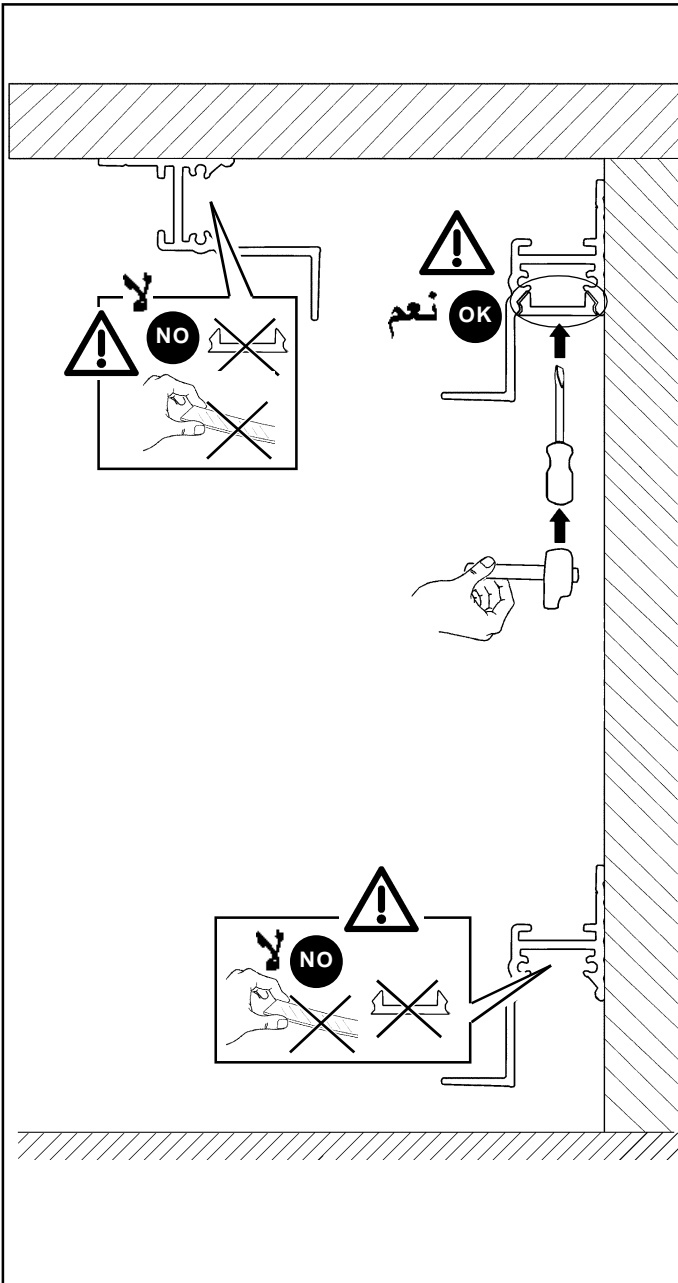

art. MXQ5

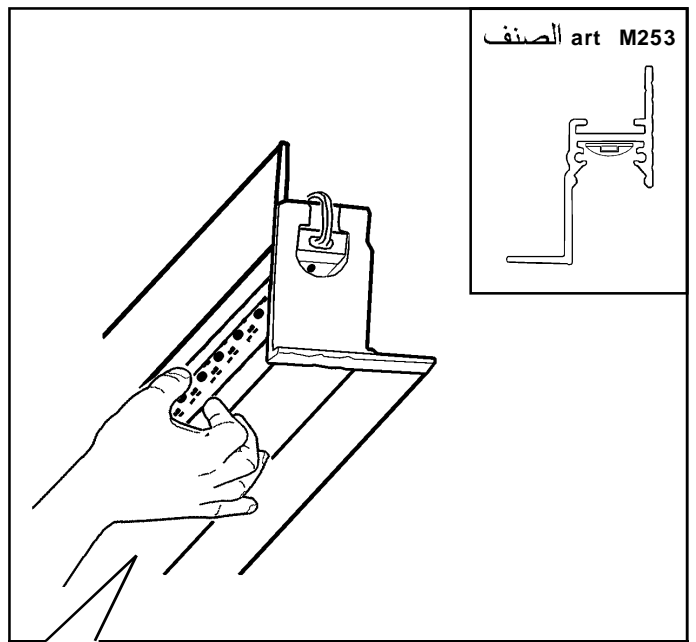
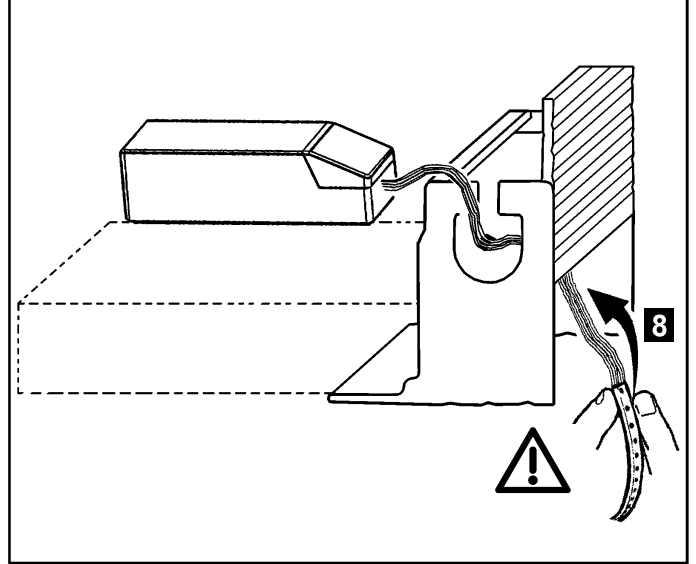
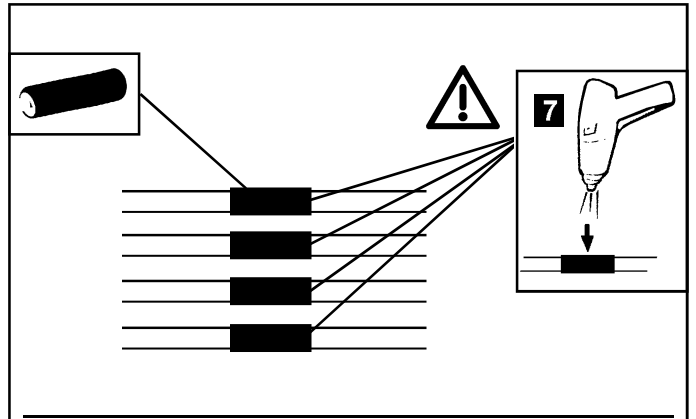
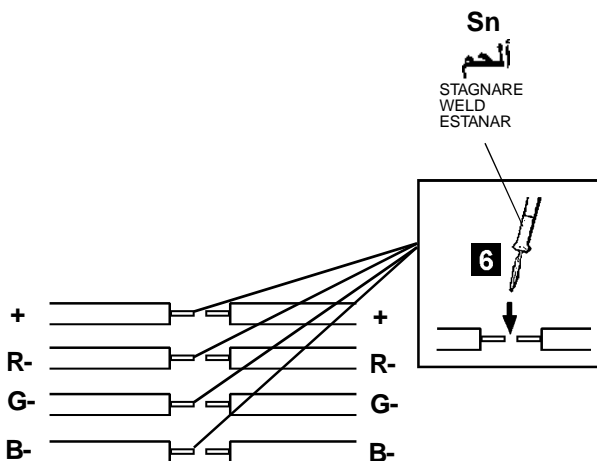
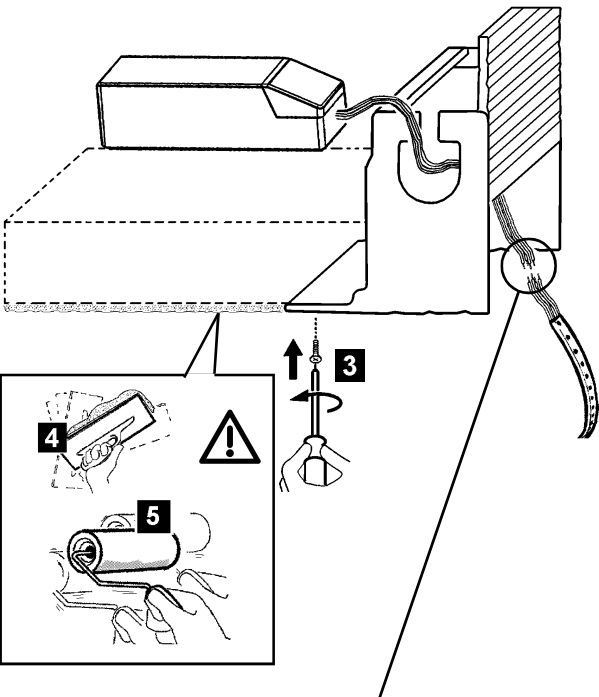
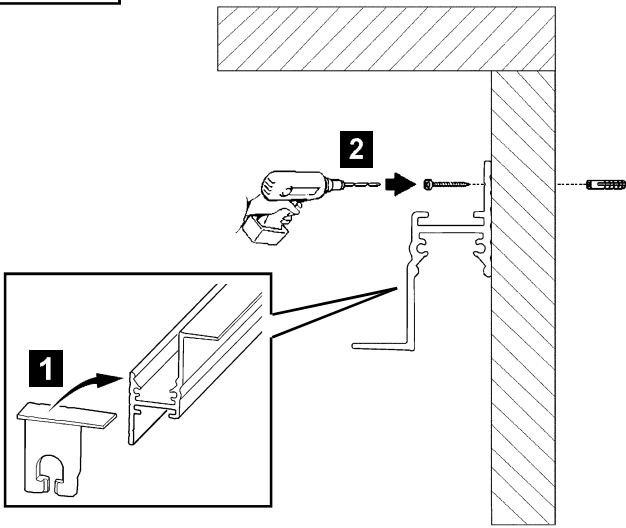
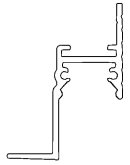

الصفن art M253

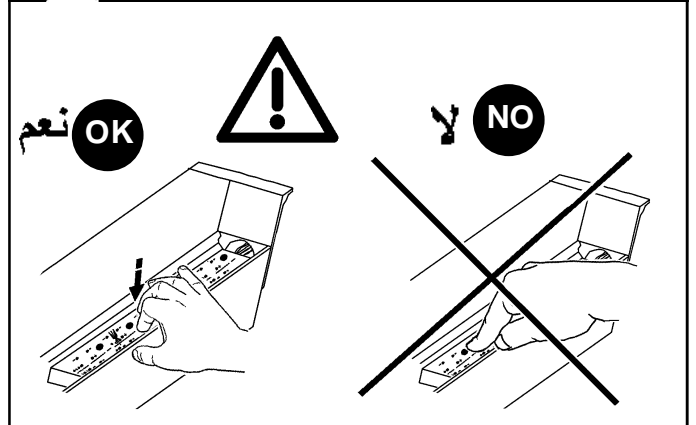
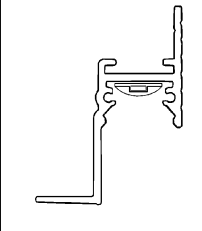



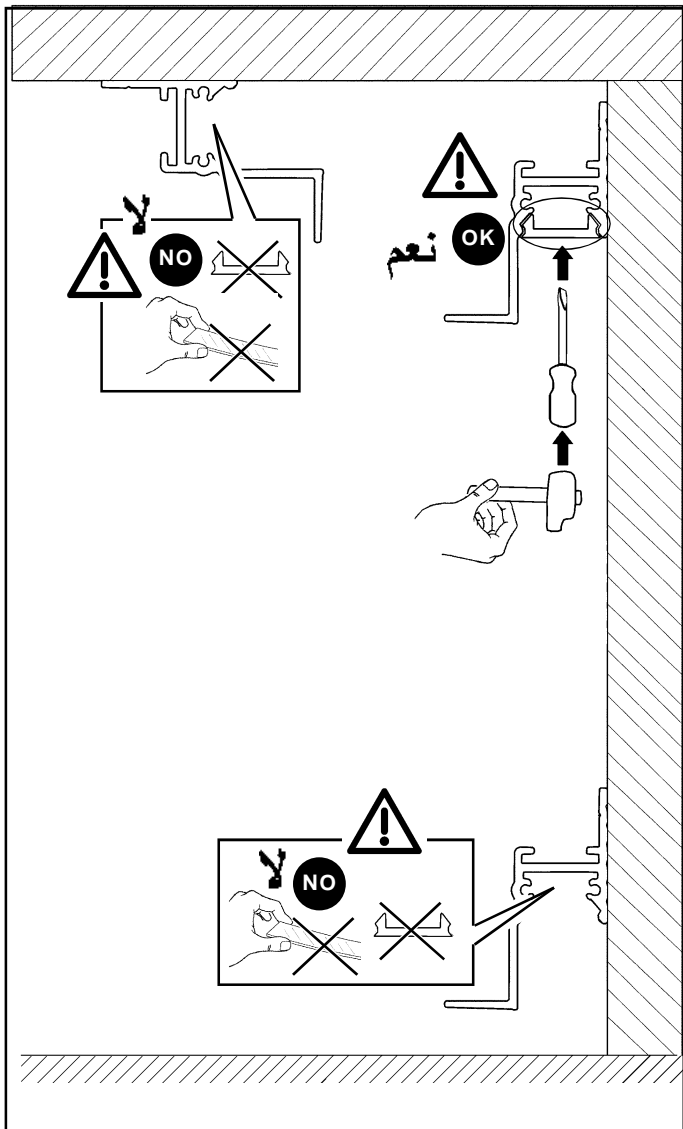
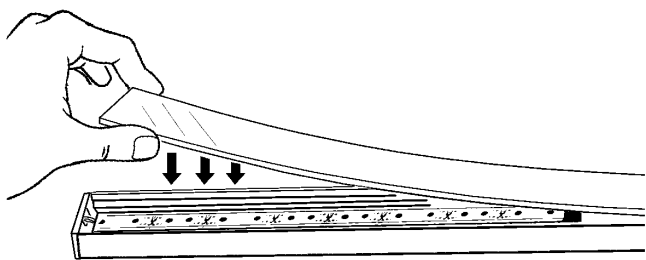

1.154.544.00

IS00766/05

**SOSTITUZIONE DEL LED**  
**REPLACING THE LED**  
**REPLACEMENT DE LA LED**  
**AUSTAUSCHEN DER LED**  
**VERVANGEN VAN DE LED**  
**REEMPLAZO DEL LED**  
**UDSKIFTNING AF LYSDIODE**  
**BYTE AV LYSDIOD**  
**UTSKIFTING AV DEN LYSEMITTERENDE DIODEN**  
**ЗАМЕНА СИДа**  
**发光二极管替换**

**I N.B.:** Per la sostituzione del LED contattare l'azienda iGuzzini.

**GB N.B.:** For information on LED replacement please contact iGuzzini.

**F N.B.:** Pour procéder au remplacement de la LED, adressez-vous à la société iGuzzini.

**D N.B.:** Bezüglich des Austausches der LED kontaktieren Sie bitte die Firma iGuzzini.

**NL N.B.:** Voor het vervangen van de LED neemt u contact op met het bedrijf iGuzzini.

**E NOTA:** Para sustituir el LED llame a la empresa iGuzzini.

**DK N.B.:** For udskiftning af lysdioden, skal man kontakte iGuzzini.

**N N.B.:** For informasjon om skifte av LED, vennligst ta kontakt med iGuzzini.

**S OBS!** För byte av lysdioden, kontakta företaget iGuzzini.

**RUS ПРИМЕЧАНИЕ:**Для замены СИДов обращайтесь в компанию iGuzzini.

**CN 注意:** 如需LED更换的信息, 请联系iGuzzini.

**I** Gruppo di rischio 1, secondo norma **EN 62471: 2008**  
**GB** Risk Group: 1, in compliance with Standard **EN 62471: 2008**  
**FR** Groupe de risque 1, suivant la norme **EN 62471 : 2008**  
**DE** Risikogruppe 1, gemäß Vorschrift **EN 62471: 2008**  
**NL** Risicogroep 1, volgens de norm **EN 62471: 2008**  
**E** Grupo de riesgo 1, según norma **EN 62471: 2008**  
**DK** Faregruppe 1 i henhold til standarden **EN 62471: 2008**  
**N** Risikogruppe 1, i henhold til forskriften **EN 62471: 2008**  
**S** Riskgrupp 1, enligt standard **EN 62471: 2008**  
**RUS** ГРУПП РИСК 1 В СООТВЕТСТВИИ СО **EN 62471: 2008**

**CN** 风险组:1  
灯具和灯具系统的光生物学安全性符合标准 **EN 62471: 2008**

**iGuzzini**

1.154.544.00

IS00766/05

**SOSTITUZIONE DEL LED**  
**REPLACING THE LED**  
**REPLACEMENT DE LA LED**  
**AUSTAUSCHEN DER LED**  
**VERVANGEN VAN DE LED**  
**REEMPLAZO DEL LED**  
**UDSKIFTNING AF LYSDIODE**  
**BYTE AV LYSDIOD**  
**UTSKIFTING AV DEN LYSEMITTERENDE DIODEN**  
**ЗАМЕНА СИДа**  
**发光二极管替换**

**I N.B.:** Per la sostituzione del LED contattare l'azienda iGuzzini.

**GB N.B.:** For information on LED replacement please contact iGuzzini.

**F N.B.:** Pour procéder au remplacement de la LED, adressez-vous à la société iGuzzini.

**D N.B.:** Bezüglich des Austausches der LED kontaktieren Sie bitte die Firma iGuzzini.

**NL N.B.:** Voor het vervangen van de LED neemt u contact op met het bedrijf iGuzzini.

**E NOTA:** Para sustituir el LED llame a la empresa iGuzzini.

**DK N.B.:** For udskiftning af lysdioden, skal man kontakte iGuzzini.

**N N.B.:** For informasjon om skifte av LED, vennligst ta kontakt med iGuzzini.

**S OBS!** För byte av lysdioden, kontakta företaget iGuzzini.

**RUS ПРИМЕЧАНИЕ:**Для замены СИДов обращайтесь в компанию iGuzzini.

**CN 注意:** 如需LED更换的信息, 请联系iGuzzini.

**I** Gruppo di rischio 1, secondo norma **EN 62471: 2008**  
**GB** Risk Group: 1, in compliance with Standard **EN 62471: 2008**  
**FR** Groupe de risque 1, suivant la norme **EN 62471 : 2008**  
**DE** Risikogruppe 1, gemäß Vorschrift **EN 62471: 2008**  
**NL** Risicogroep 1, volgens de norm **EN 62471: 2008**  
**E** Grupo de riesgo 1, según norma **EN 62471: 2008**  
**DK** Faregruppe 1 i henhold til standarden **EN 62471: 2008**  
**N** Risikogruppe 1, i henhold til forskriften **EN 62471: 2008**  
**S** Riskgrupp 1, enligt standard **EN 62471: 2008**  
**RUS** ГРУПП РИСК 1 В СООТВЕТСТВИИ СО **EN 62471: 2008**

**CN** 风险组:1  
灯具和灯具系统的光生物学安全性符合标准 **EN 62471: 2008**

**iGuzzini**

1.154.544.00

IS00766/05

**SOSTITUZIONE DEL LED**  
**REPLACING THE LED**  
**REPLACEMENT DE LA LED**  
**AUSTAUSCHEN DER LED**  
**VERVANGEN VAN DE LED**  
**REEMPLAZO DEL LED**  
**UDSKIFTNING AF LYSDIODE**  
**BYTE AV LYSDIOD**  
**UTSKIFTING AV DEN LYSEMITTERENDE DIODEN**  
**ЗАМЕНА СИДа**  
**发光二极管替换**

**I N.B.:** Per la sostituzione del LED contattare l'azienda iGuzzini.

**GB N.B.:** For information on LED replacement please contact iGuzzini.

**F N.B.:** Pour procéder au remplacement de la LED, adressez-vous à la société iGuzzini.

**D N.B.:** Bezüglich des Austausches der LED kontaktieren Sie bitte die Firma iGuzzini.

**NL N.B.:** Voor het vervangen van de LED neemt u contact op met het bedrijf iGuzzini.

**E NOTA:** Para sustituir el LED llame a la empresa iGuzzini.

**DK N.B.:** For udskiftning af lysdioden, skal man kontakte iGuzzini.

**N N.B.:** For informasjon om skifte av LED, vennligst ta kontakt med iGuzzini.

**S OBS!** För byte av lysdioden, kontakta företaget iGuzzini.

**RUS ПРИМЕЧАНИЕ:**Для замены СИДов обращайтесь в компанию iGuzzini.

**CN 注意:** 如需LED更换的信息, 请联系iGuzzini.

**I** Gruppo di rischio 1, secondo norma **EN 62471: 2008**  
**GB** Risk Group: 1, in compliance with Standard **EN 62471: 2008**  
**FR** Groupe de risque 1, suivant la norme **EN 62471 : 2008**  
**DE** Risikogruppe 1, gemäß Vorschrift **EN 62471: 2008**  
**NL** Risicogroep 1, volgens de norm **EN 62471: 2008**  
**E** Grupo de riesgo 1, según norma **EN 62471: 2008**  
**DK** Faregruppe 1 i henhold til standarden **EN 62471: 2008**  
**N** Risikogruppe 1, i henhold til forskriften **EN 62471: 2008**  
**S** Riskgrupp 1, enligt standard **EN 62471: 2008**  
**RUS** ГРУПП РИСК 1 В СООТВЕТСТВИИ СО **EN 62471: 2008**

**CN** 风险组:1  
灯具和灯具系统的光生物学安全性符合标准 **EN 62471: 2008**

**iGuzzini**

2.509.216.00  
IS05718/01

استبدال الضوء LED  
SOSTITUZIONE DEL LED  
REPLACING THE LED  
REEMPLAZO DEL LED

تنبیه: لاستبدال الضوء LED اتصل بشركة iGuzzini .

I N.B.: Per la sostituzione del LED contattare l'azienda iGuzzini.

GB N.B.: For information on LED replacement please contact iGuzzini.

E NOTA: Para sustituir el LED llame a la empresa iGuzzini.

فئة الخطر 1، حسب مقاييس EN 62471: 2008 .

I Gruppo di rischio 1, secondo norma EN 62471: 2008

GB Risk Group: 1, in compliance with Standard EN 62471: 2008

E Grupo de riesgo 1, según norma EN 62471: 2008

iGuzzini

2.509.216.00  
IS05718/01

استبدال الضوء LED  
SOSTITUZIONE DEL LED  
REPLACING THE LED  
REEMPLAZO DEL LED

تنبیه: لاستبدال الضوء LED اتصل بشركة iGuzzini .

I N.B.: Per la sostituzione del LED contattare l'azienda iGuzzini.

GB N.B.: For information on LED replacement please contact iGuzzini.

E NOTA: Para sustituir el LED llame a la empresa iGuzzini.

فئة الخطر 1، حسب مقاييس EN 62471: 2008 .

I Gruppo di rischio 1, secondo norma EN 62471: 2008

GB Risk Group: 1, in compliance with Standard EN 62471: 2008

E Grupo de riesgo 1, según norma EN 62471: 2008

iGuzzini

2.509.216.00  
IS05718/01

استبدال الضوء LED  
SOSTITUZIONE DEL LED  
REPLACING THE LED  
REEMPLAZO DEL LED

تنبیه: لاستبدال الضوء LED اتصل بشركة iGuzzini .

I N.B.: Per la sostituzione del LED contattare l'azienda iGuzzini.

GB N.B.: For information on LED replacement please contact iGuzzini.

E NOTA: Para sustituir el LED llame a la empresa iGuzzini.

فئة الخطر 1، حسب مقاييس EN 62471: 2008 .

I Gruppo di rischio 1, secondo norma EN 62471: 2008

GB Risk Group: 1, in compliance with Standard EN 62471: 2008

E Grupo de riesgo 1, según norma EN 62471: 2008

iGuzzini

2.509.216.00  
IS05718/01

استبدال الضوء LED  
SOSTITUZIONE DEL LED  
REPLACING THE LED  
REEMPLAZO DEL LED

تنبیه: لاستبدال الضوء LED اتصل بشركة iGuzzini .

I N.B.: Per la sostituzione del LED contattare l'azienda iGuzzini.

GB N.B.: For information on LED replacement please contact iGuzzini.

E NOTA: Para sustituir el LED llame a la empresa iGuzzini.

فئة الخطر 1، حسب مقاييس EN 62471: 2008 .

I Gruppo di rischio 1, secondo norma EN 62471: 2008

GB Risk Group: 1, in compliance with Standard EN 62471: 2008

E Grupo de riesgo 1, según norma EN 62471: 2008

iGuzzini

2.509.216.00  
IS05718/01

استبدال الضوء LED  
SOSTITUZIONE DEL LED  
REPLACING THE LED  
REEMPLAZO DEL LED

تنبیه: لاستبدال الضوء LED اتصل بشركة iGuzzini .

I N.B.: Per la sostituzione del LED contattare l'azienda iGuzzini.

GB N.B.: For information on LED replacement please contact iGuzzini.

E NOTA: Para sustituir el LED llame a la empresa iGuzzini.

فئة الخطر 1، حسب مقاييس EN 62471: 2008 .

I Gruppo di rischio 1, secondo norma EN 62471: 2008

GB Risk Group: 1, in compliance with Standard EN 62471: 2008

E Grupo de riesgo 1, según norma EN 62471: 2008

iGuzzini

- I Istruzioni per le operazioni di servizio per l'apparecchio di illuminazione**  
**GB Instructions on luminaire service operations**  
**F Instructions pour les opérations de service du luminaire**  
**D Wartungsanleitung für die Leuchte**  
**NL Instructies voor de onderhoudsoperaties op de verlichtingsarmatuur**  
**E Instrucciones para las operaciones de servicio del aparato de alumbrado**  
**DK Anvisninger i serviceindgreb på belysningsarmatur**  
**N Anvisninger for betjening av lysapparatet**  
**S Instruktioner för användning av belysningsanordningen**  
**RUS Инструкция по эксплуатации осветительного прибора**  
**CN 照明装置检修操作说明**

**Sostituire la lampada parzialmente esausta**  
 Replace the partly exhausted lamp  
 Remplacer la lampe partiellement épuisée  
 Die teilweise erschöpfte Lampe austauschen  
 Vervang de gedeeltelijk lege lamp  
 Sustituir la lámpara parzialmente agotada  
 Udskift den delvist udtjente pære  
 Skifte ut den delvis utbrente lyspæren  
 Byt ut den delvis förbrukade lampan  
 Замена частично отработанной лампочки  
 更换部分老化的灯泡



**Spegnimento**  
 Switch it off  
 Extinction  
 Ausschaltung  
 Uitschakeling  
 Apagado  
 Slukning  
 Slukking  
 Släckning  
 Выключение  
 关灯

**Interrompere l'alimentazione dell'apparecchio**  
 Cut the power supply to the luminaire  
 Couper l'alimentation du luminaire  
 Stromversorgung der Leuchte unterbrechen  
 Onderbreek de voeding van het apparaat  
 Interrumpir la alimentación del aparato  
 Afbryd armaturets strømforsyning  
 Avbryt strømtilførselen til apparatet  
 Koppla från anordningens strömförsörjning  
 Отключить электропитание прибора  
 中断装置供电



**Aprire l'apparecchio**  
 Open the fixture  
 Ouvrir le luminaire  
 Das Gerät öffnen  
 Open het apparaat  
 Abrir el aparato  
 Åbn armaturet  
 Åpne apparatet  
 Öppna anordningen  
 Раскрыть прибор  
 打开装置



**Rimuovere la lampada esausta**  
 Remove the exhausted lamp  
 Retirer la lampe épuisée  
 Die alte Lampe entnehmen  
 Verwijder de lege lamp  
 Quitar la lámpara agotada  
 Tag den udtjente pære ud  
 Fjerne den utbrente lyspæren  
 Ta bort den förbrukade lampan  
 Вынуть старую лампочку  
 取出老化的灯泡

**Portarla in un centro di riciclaggio**  
 Carry it to a recycling centre  
 La porter dans une déchetterie pour son recyclage  
 Ordnungsgemäß entsorgen  
 Breng de lamp naar een recyclingcentrum  
 Llevarla a un centro de reciclaje  
 Aflever den på en genbrugsstation  
 Lever den til en miljøstasjon  
 Lämna in den till en återvinningsanläggning  
 Сдать ее в пункт приема утильсырья  
 将其送往回收中心



**Inserire la nuova lampada**  
 Introduce the new lamp  
 Installer la lampe neuve  
 Die neue Lampe einsetzen  
 Doe de nieuwe lamp op zijn plek  
 Montar la nueva lámpara  
 Sæt den nye pære i  
 Sette i den nye pæren  
 Sätt i den nya lampan  
 Вставить новую лампочку  
 装入新灯泡

**Inserire la nuova lampada nel portalampana**  
 Fit the new lamp into the socket  
 Installer la nouvelle lampe dans le support de lampe  
 Die neue Lampe in den Sockel einsetzen  
 Doe de nieuwe lamp in de lamphouder  
 Montar la nueva lámpara en el portalampana  
 Sæt den nye pære i fatningen  
 Sette den nye pæren inn i lampeholderen  
 Sätt i den nya lampan i lamphållaren  
 Вставить новую лампочку в патрон  
 将新灯泡插入灯泡架中



**Riposizionare ottica**  
 Re-place the optic  
 Remettre l'optique à sa place  
 Die Optik wieder einsetzen  
 Doe de optiek weer op zijn plaats  
 Volver a montar la óptica  
 Sæt den optiske enhed på plads  
 Innstille linsen  
 Flytta om optiken  
 Отрегулировать линзы  
 重新定位光头



**Effettuare prova di funzionamento**  
 Perform operative test  
 Procéder à un essai de fonctionnement  
 Eine Funktionsprüfung durchführen  
 Controleer de correcte werking  
 Hacer una prueba de funcionamiento  
 Afprøv funktionen  
 Prøve om den fungerer  
 Utför funktionstest  
 Выполнить проверку исправности работы  
 执行功能测试



**I Istruzioni per la pulizia dell'apparecchio di illuminazione**  
**GB Instructions on luminaire cleaning operations**  
**F Instructions pour le nettoyage du luminaire**  
**D Anweisungen zur Reinigung der Leuchte**  
**NL Instructies voor de reiniging van de verlichtingsarmatuur**  
**E Instrucciones para limpiar el aparato de alumbrado**  
**DK Anvisninger i rengøring af belysningsarmaturet**  
**N Anvisninger for rengjøring av lysapparatet**  
**S Instruktioner för rengöring av belysningsanordningen**  
**RUS Инструкции по чистке осветительного прибора**  
**CN 照明装置清洁说明**

**Pulire l'apparecchio**  
**Clean the fixture**  
**Nettoyer le luminaire**  
**Das Gerät reinigen**  
**Reinig het apparaat**  
**Limpiar el aparato**  
**Rengør armaturet**  
**Rengjøre apparatet**  
**Rengör anordningen**  
**Чистка прибора**  
**清洁装置**



**Spegnimento**  
**Switch it off**  
**Extinction**  
**Ausschaltung**  
**Uitschakeling**  
**Apagado**  
**Slukning**  
**Slukking**  
**Släckning**  
**Выключение**  
**关灯**

**Interrompere l'alimentazione dell'apparecchio**  
**Cut the power supply to the luminaire**  
**Couper l'alimentation du luminaire**  
**Stromversorgung der Leuchte unterbrechen**  
**Onderbreek de voeding van het apparaat**  
**Interrumpir la alimentación del aparato**  
**Afbryd armaturets strømforstyrning**  
**Avbryt strømtilførselen til apparatet**  
**Koppla från anordningens strömförsörjning**  
**Отключить электропитание прибора**  
**中断装置供电**



**Spolverare l'ottica esterna**  
**Remove dust from the external optic**  
**Dépoussiérer l'optique extérieure**  
**Die externe Optik abstauben**  
**Stof de externe optiek af**  
**Quitar el polvo de la óptica exterior**  
**Tør støvet af den udvendige optiske enhed**  
**Fjerne støv fra den eksterne lysenheden**  
**Damma av den yttre optiken**  
**Вытереть пыль с внешней стороны линз**  
**为外侧光头掸尘**



**Lavare l'ottica esterna**  
**Wash the external optic**  
**Laver l'optique extérieure**  
**Die externe Optik waschen**  
**Was de externe optiek**  
**Lavar la óptica exterior**  
**Vask den udvendige optiske enhed**  
**Vaske den eksterne lysenheden**  
**Rengör den yttre optiken**  
**Вымыть линзы с внешней стороны**  
**清洁外光头**



**Rimuovere l'ottica**  
**Remove the optic**  
**Retirer l'optique**  
**Die Optik abnehmen**  
**Verwijder de optiek**  
**Quitar la óptica**  
**Tag den optiske enhed af**  
**Fjerne lysenheden**  
**Ta bort optiken**  
**Снять линзы**  
**取下光头**



**Pulire la parte interna dell'apparecchio di illuminazione**  
**Clean the inside of the fixture**  
**Nettoyer l'intérieur du luminaire**  
**Die Innenseite der Leuchte reinigen**  
**Reinig de binnenzijde van de verlichtingsarmatuur**  
**Limpiar el interior del aparato de alumbrado**  
**Rengør belysningsarmaturets indvendige dele**  
**Rengjøre lysapparatet innvendig**  
**Rengör belysningsanordningen invändigt**  
**Протереть осветительный прибор изнутри**  
**清洁照明装置内部**



**Riposizionare ottica**  
**Re-place the optic**  
**Remettre l'optique à sa place**  
**Die Optik wieder einsetzen**  
**Doe de optiek weer op zijn plaats**  
**Volver a montar la óptica**  
**Sæt den optiske enhed på plads**  
**Innstille linsen**  
**Flytta om optiken**  
**Отрегулировать линзы**  
**重新定位光头**



**Effettuare prova di funzionamento**  
**Perform operative test**  
**Procéder à un essai de fonctionnement**  
**Eine Funktionsprüfung durchführen**  
**Controleer de correcte werking**  
**Hacer una prueba de funcionamiento**  
**Afprøv funktionen**  
**Prøve om den fungerer**  
**Utför funktionstest**  
**Выполнить проверку исправности работы**  
**执行功能测试**

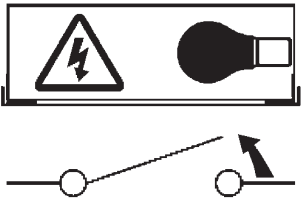
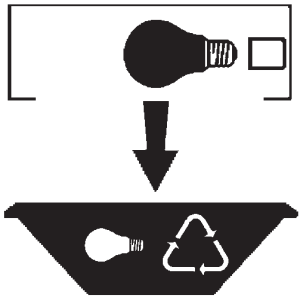
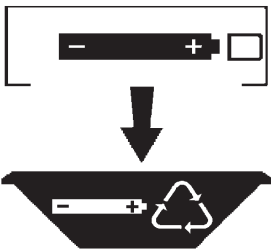
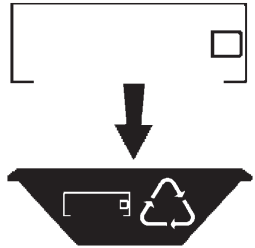

- I** Istruzioni per il fine vita e lo smaltimento dei componenti  
**GB** Instructions on end-of-life and component disposal  
**F** Instructions pour la gestion des composants en fin de vie et leur mise au rebut  
**D** Anweisungen zur Entsorgung der Leuchtenkomponenten  
**NL** Instructies voor het verwijderen van de armatuur en het recyclen van de onderdelen  
**E** Instrucciones para el final de vida y la eliminación los componentes  
**DK** Anvisninger i udtjent armatur og bortskaffelse af komponenter  
**N** Anvisninger for endt levetid og avfallsbehandling av delene  
**S** Instruktioner vid bortskaffning och kassering av komponenter  
**RUS** Инструкции по утилизации прибора и его комплектующих по окончании его срока службы  
**CN** 寿命期结束与零件废弃处置说明

<p>Spegnimento Switch it off Extinction Ausschaltung Uitschakeling Apagado Slukning Slukking Släckning Выключение 关灯</p> <p>Interrompere l'alimentazione dell'apparecchio Cut the power supply to the luminaire Couper l'alimentation du luminaire Stromversorgung der Leuchte unterbrechen Onderbreek de voeding van het apparaat Interrompirla alimentación del aparato Afbryd armaturets strømforsyning Avbryt strømtilførselen til apparatet Koppla från anordningens strömförsörjning Отключить электропитание прибора 中断装置供电</p> 	<p>Rimuovere la/e lampada/e per la dismissione Remove the lamp(s) for decommissioning Retirer la(les) lampe(s) pour sa(leur) mise au rebut Die Lampe/n ordnungsgemäß entsorgen Verwijder de lamp(en) voor het recyclen Quitar la(s) lámpara(s) para el desecho Tag pæren/pærerne ud til bortskaffelse Fjerne lampen/-e som skal kastes Ta bort lampan/-orna för bortskaffningen Вынуть лампочку/и для утилизации прибора 取出需要丢弃的灯泡</p> 	<p>Rimuovere la batteria per la dismissione Remove the battery for decommissioning Retirer la batterie pour sa mise au rebut Die Batterie ordnungsgemäß entsorgen Verwijder de batterij voor het recyclen Quitar la batería para el desecho Tag batteriet ud til bortskaffelse Fjerne batteriet som skal kastes Ta bort batteriet för bortskaffningen Вынуть батарейку для утилизации прибора 取出需要丢弃的电池</p> 	<p>Rimuovere l'apparecchio per la dismissione Remove the fixture for decommissioning Enlever le luminaire pour sa mise au rebut Das Gerät ordnungsgemäß entsorgen Verwijder het apparaat voor het recyclen Quitar el aparato para el desecho Tag armaturet ud til bortskaffelse Fjerne apparatet som skal kastes Ta bort anordningen för bortskaffningen Снять прибор для утилизации 取出需要丢弃的装置</p> 
<p>Inviare i materiali ad un centro di raccolta RAEE Send the materials to a WEEE collection centre Envoyer les matériaux dans une déchetterie DEEE Die Materialien in einem WEEE-Zentrum entsorgen Zend de materialen naar een recyclingscentrum voor de AEEA Enviar los materiales a un centro de recogida RAEE Afløver materialerne på et indsamlingscenter for elektronisk udstyr Sende materialene til en miljøstasjon for resirkulering av EE-avfall Skicka materialet till en RAEE uppsamlingscentral Сдать материалы в пункт приема утильсырья 将材料送往电气和电子垃圾回收中心</p> 