

LASER BLADE IN OUT 5x / 10x / 15x

MINIMAL

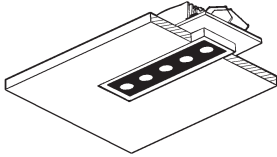

FRAME

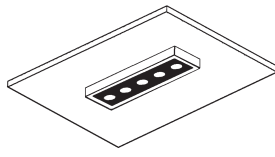

I ATTENZIONE:

LA SICUREZZA DELL'APPARECCHIO E' GARANTITA SOLO CON L'USO APPROPRIATO DELLE SEGUENTI ISTRUZIONI; PERTANTO E' NECESSARIO CONSERVARLE.

GB WARNING:

THE SAFETY OF THIS FIXTURE IS GUARANTEED ONLY IF YOU COMPLY WITH THESE INSTRUCTIONS; REMEMBER TO CONSERVE IN A SAFE PLACE.

F ATTENTION:

LA SECURITE DE L'APPAREIL N'EST GARANTIE QU'EN CAS D'UTILISATION CORRECTE DES INSTRUCTIONS SUIVANTES; IL FAUT PAR CONSEQUENT LES CONSERVER.

D ACHTUNG:

DIE SICHERHEIT DES GERÄTES WIRD NUR DURCH SACHGEMÄSSE BEFOLGUNG NACHSTEHENDER ANWEISUNGEN GEWÄHRLEISTET; IHRE AUFBEWAHRUNG IST DESHALB SEHR WICHTIG.

NL OPGELET:

DE VEILIGHEID VAN DI ATOESTEL IS SLECHTS DAN GEGARANDEERD ALS INDIEN DE VOLGENDE INSTRUCTIES STRIKT WORDEN TOEGEPAST; DAAROM MOET MEN ZE OOK BEWAREN.

E ATENCION:

LA SEGURIDAD DEL APARATO SE GARANTIZA SOLO CUMPLIENDO CUIDADOSAMENTE LAS SIGUIENTES INSTRUCCIONES; POR ELLO, ES NECESARIO CONSERVARLAS.

DK BEMÆRK:

SIKKERHEDEN VED BRUG AF ARMATURET KAN KUN GARANTERES, HVIS DISSE ANVISNINGER FØLGES; SØRG DERFOR FOR AT GEMME DEM.

N ADVARSEL:

SIKKERHETEN TIL DETTE APPARATET GARANTERES KUN HVIS DU OVERHOLDER DISSE INSTRUKSJONENE; HUSK Å OPPBEVARE DEM PÅ ET TRYGT STED.

S OBSERVERA!

UTRUSTNINGENS SÄKERHET KAN ENDAST GARANTERAS OM DESSA ANVISNINGAR RESPEKTERAS I DETALJ. SPARA DÄRFÖR DESSA ANVISNINGAR FÖR FRAMTIDA KONSULTATION.

RUS ВНИМАНИЕ:

МЫ ГАРАНТИРУЕМ БЕЗОПАСНУЮ ЭКСПЛУАТАЦИЮ ИЗДЕЛИЯ ТОЛЬКО ПРИ СОБЛЮДЕНИИ СЛЕДУЮЩИХ ИНСТРУКЦИЙ; С ЭТОЙ ЦЕЛЬЮ НЕОБХОДИМО СОХРАНИТЬ ДАННУЮ БРОШЮРУ.

CN 警告

为确保该装置安全，请遵守操作指示；并于安全场所放置。

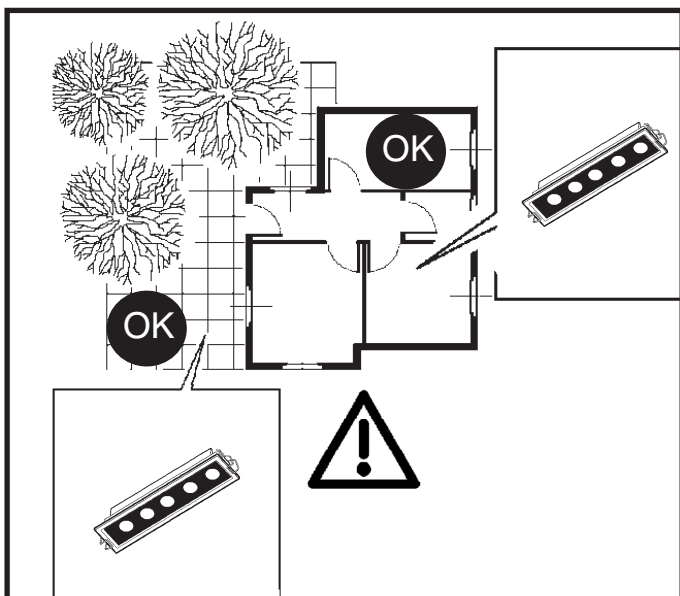
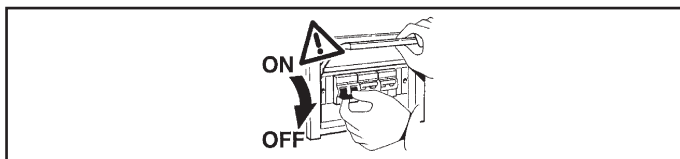
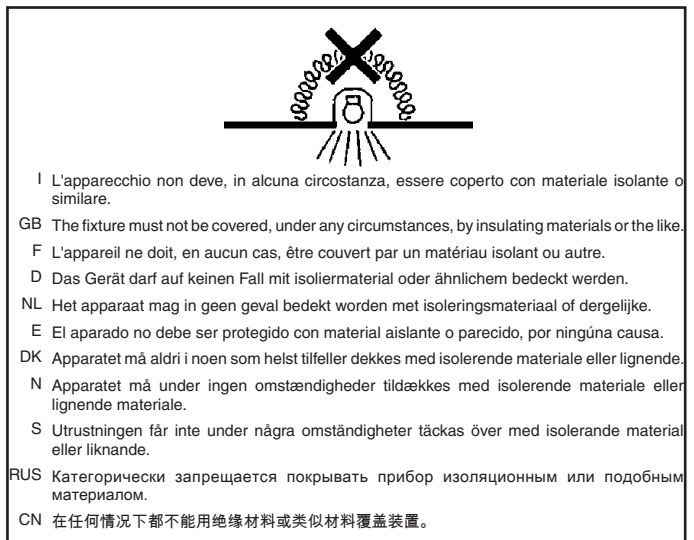
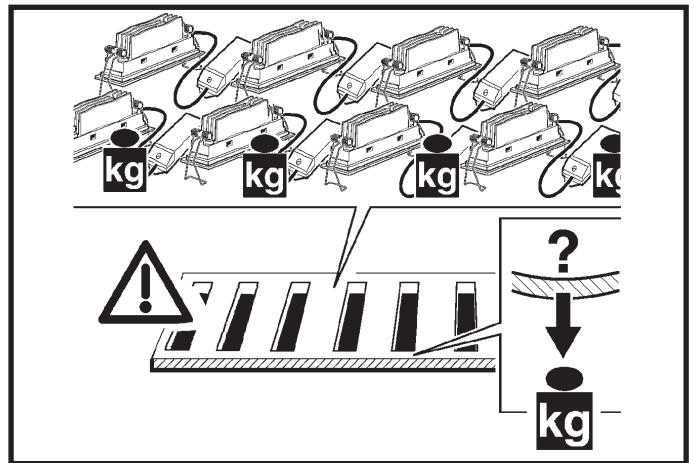
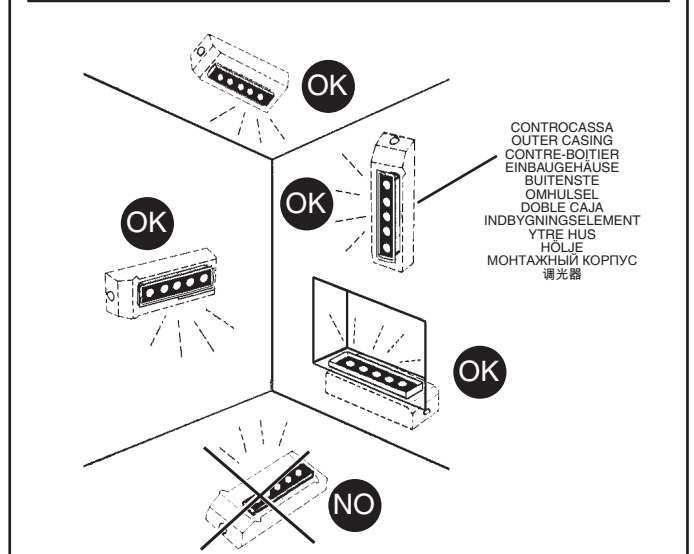
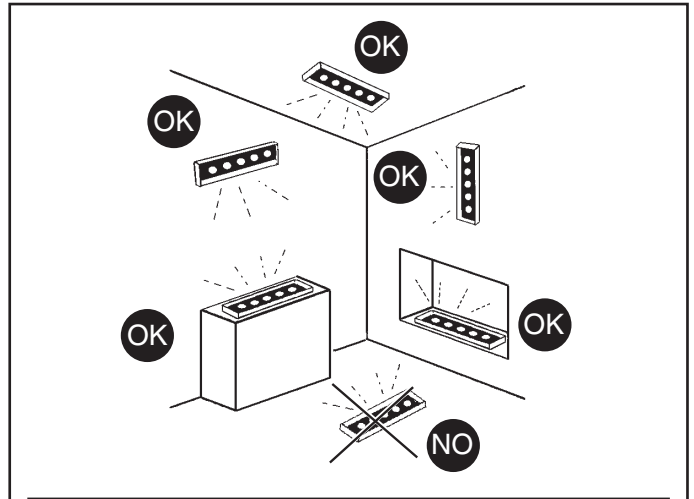

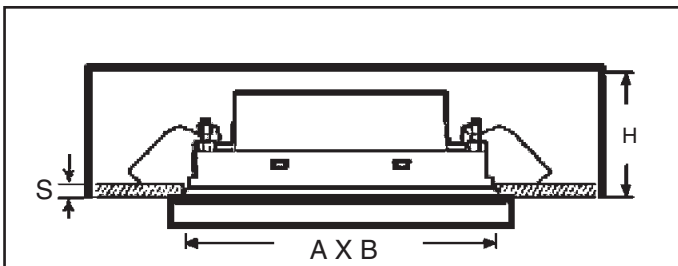
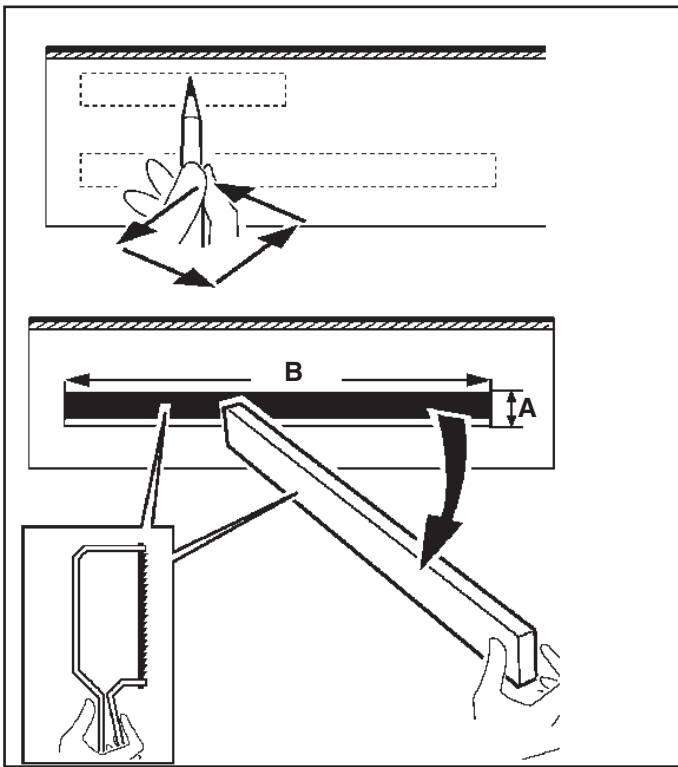

IP65

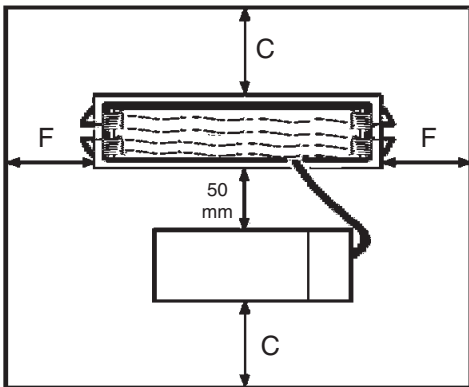

ART.	A x B mm ±0 -0	C mm	F mm	H mm	S mm
BX58 - BX59 - BX60 BX61 - BX62 - BX63 BX64 - BX65 - BX66 BX67	37 X 141	60	60	100	1-25
BX68 - BX69 - BX70 BX71 - BX72 - BX73 BX74 - BX75 - BX76 BX77	37 X 274	185	85		
BX78 - BX79 - BX80 BX81 - BX82 - BX83 BX84 - BX85 - BX86 BX87	37 X 406	235	85		

ART.	+ART.	A x B mm +2 -0	C mm	F mm	H mm	S mm
BX58 - BX59 - BX60 BX61 - BX62 - BX63 BX64 - BX65 - BX66 BX67	+ X116	56X164	60	60	115	12,5/15
BX68 - BX69 - BX70 BX71 - BX72 - BX73 BX74 - BX75 - BX76 BX77	+ X117	56X297	185	85	115	12,5/15
BX78 - BX79 - BX80 BX81 - BX82 - BX83 BX84 - BX85 - BX86 BX87	+ X118	56X430	235	85	115	12,5/15

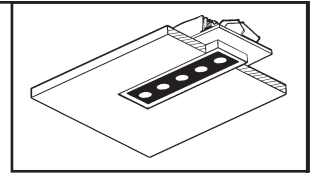

ART.	
5x	X116
10x	X117
15x	X118

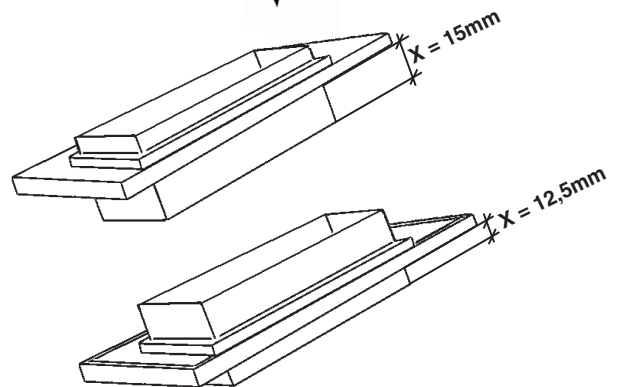
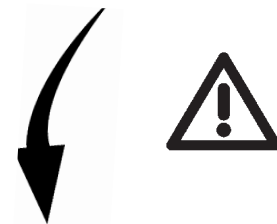
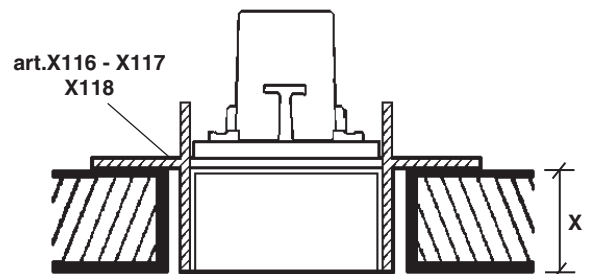

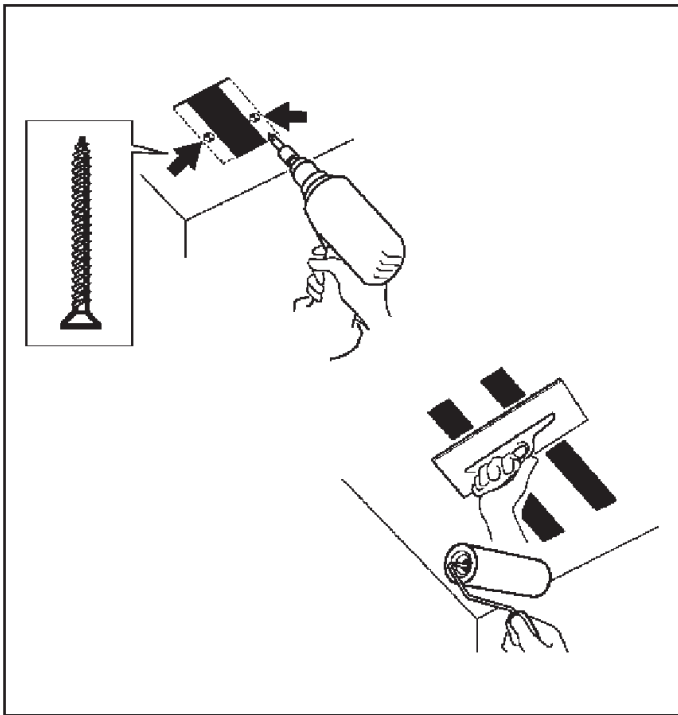

I Morsettierra non inclusa. L'installazione può richiedere l'intervento di personale qualificato

GB Terminal board not included. The aid of qualified personnel may be required for installation

F Bornier non inclus. L'installation pourrait exiger l'intervention de personnel qualifié.

D Klemmenleiste nicht enthalten. Die Installation muss gegebenenfalls von Fachkräften durchgeführt werden.

NL Klemmenstrook niet inbegrepen. De installatie kan de hulp van gekwalificeerde installateurs vereisen.

E Clema de conexiones no incluida. La instalación puede necesitar la intervención de personal calificado.

DK Klemkasse følger ikke med. Installation kan kræve hjælp fra en elektriker.

N Klembrett ikke inkludert. Installasjonen kan kreve inngrep av kvalifisert personale.

S Kopplingsplint ingår inte. Installationen kan kräva ingrepp från en utbildad fackman.

RUS Без клеммной колодки. Для монтажа может потребоваться вызвать квалифицированного электрика.

CN 注意：不包括终端板。需要专业的技师进行安装。

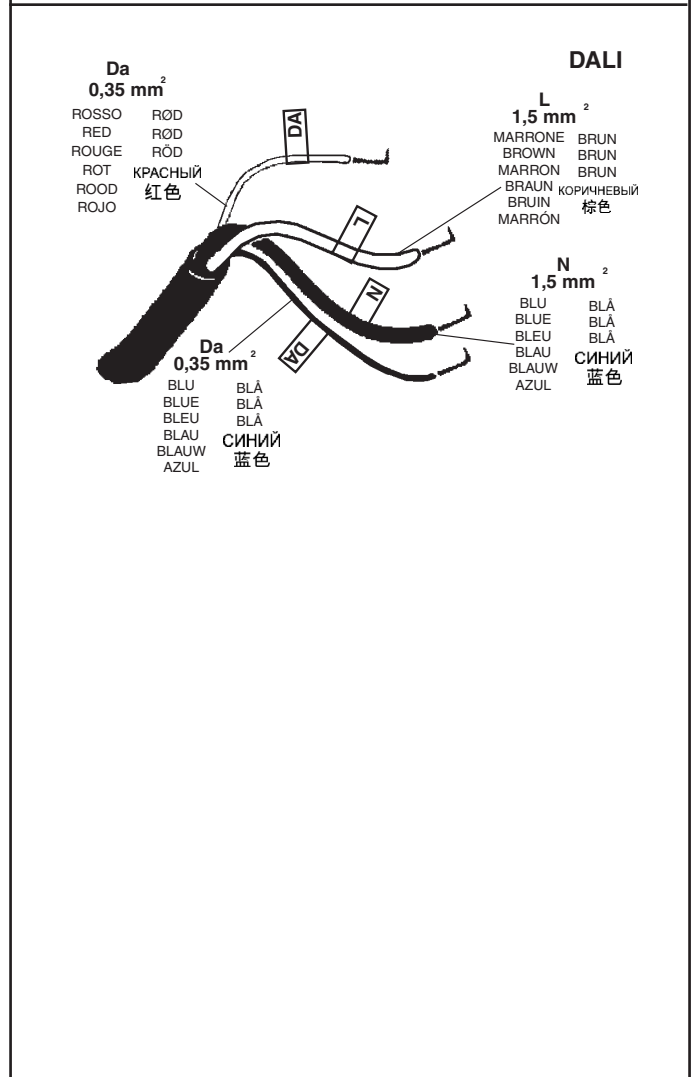
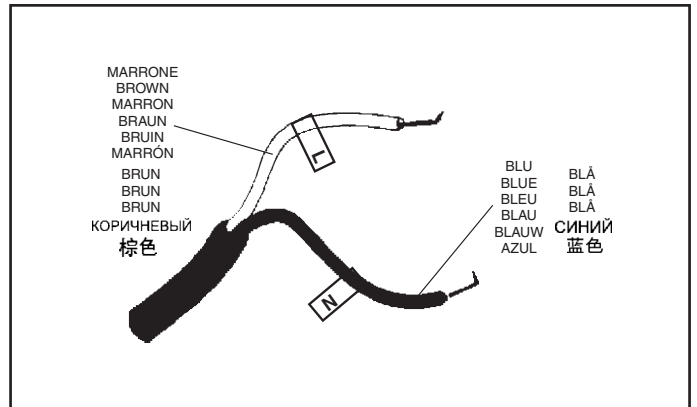
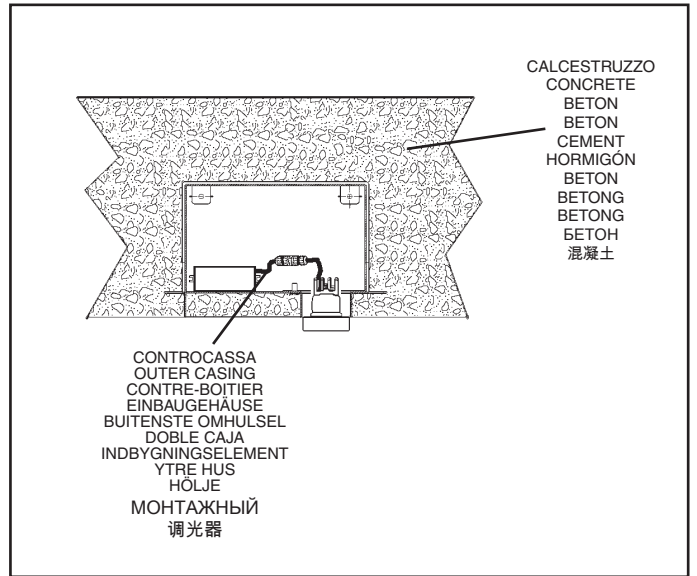
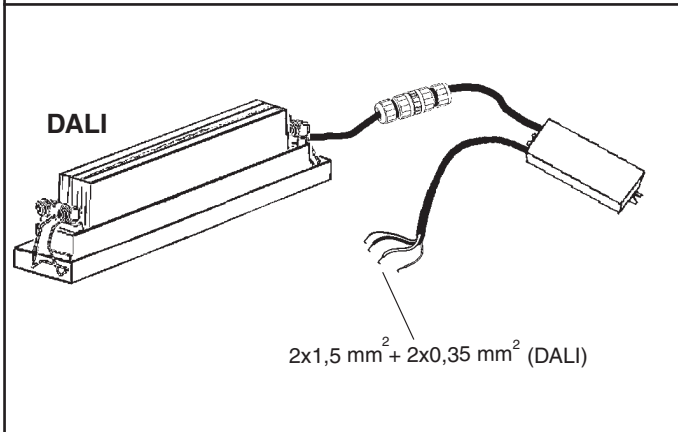
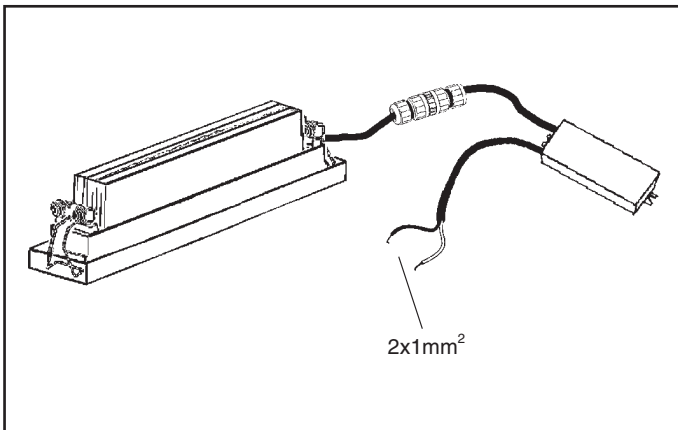

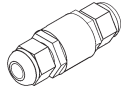
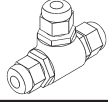
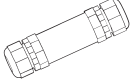
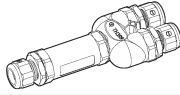
BZK6		2X
BZG8		2X
BZS6		4X
BZN7		4X

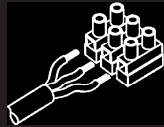

art. BZK6 - BZG8

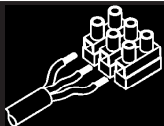
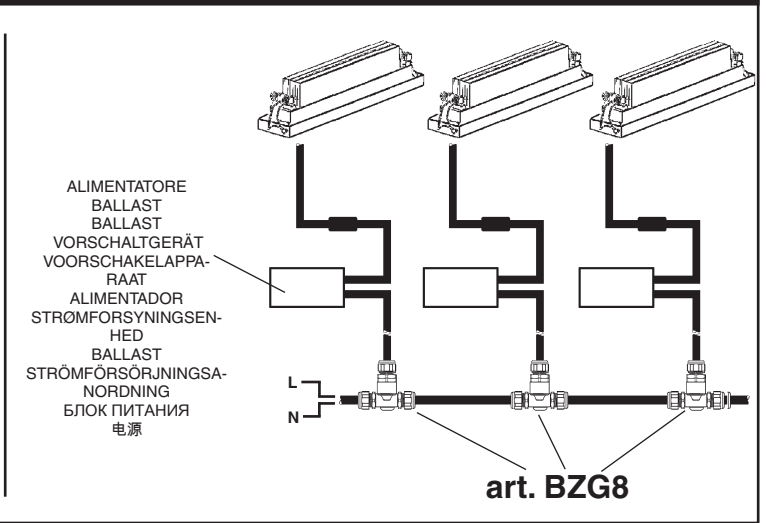
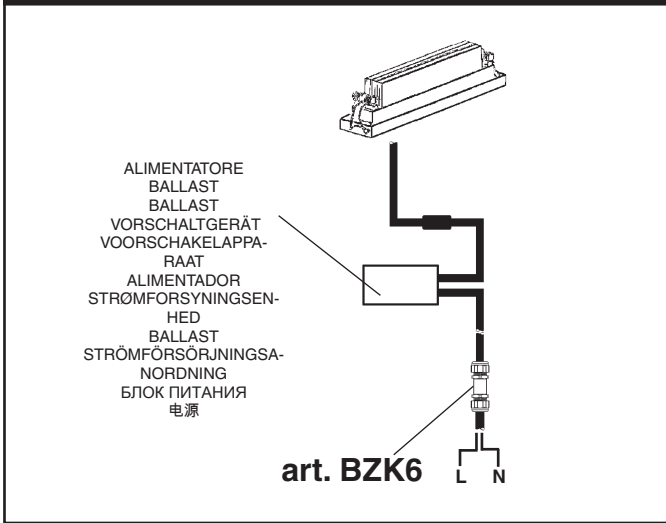

art. BZS6 - BZN7 (DALI)

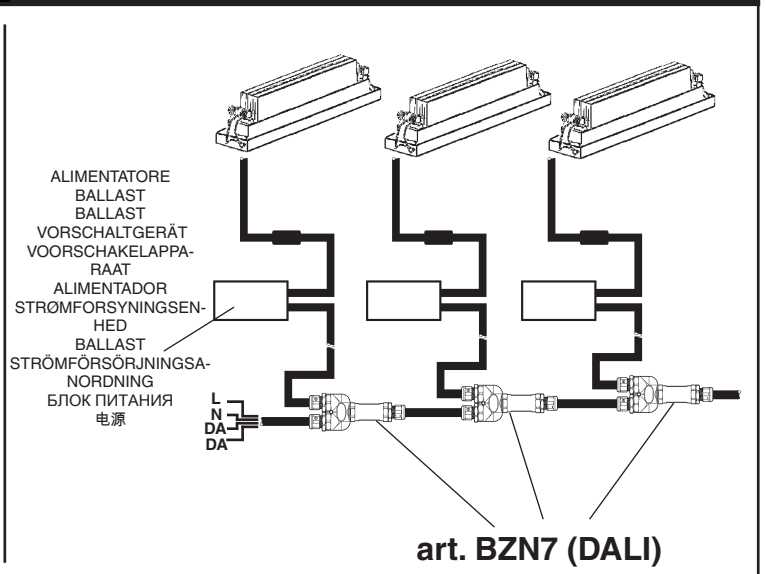
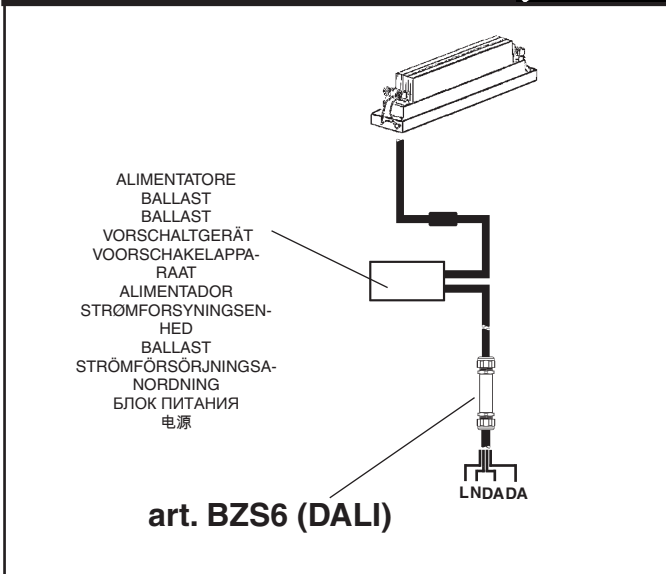

art. BZK6
BZG8

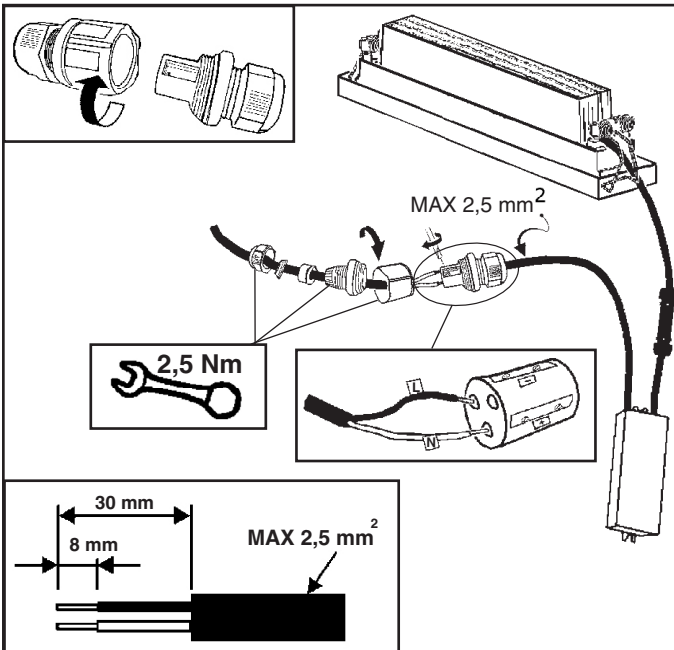

D (mm)	
6,5 ÷ 8 mm	
8 ÷ 9 mm	
9 ÷ 13 mm	

art. BZS6

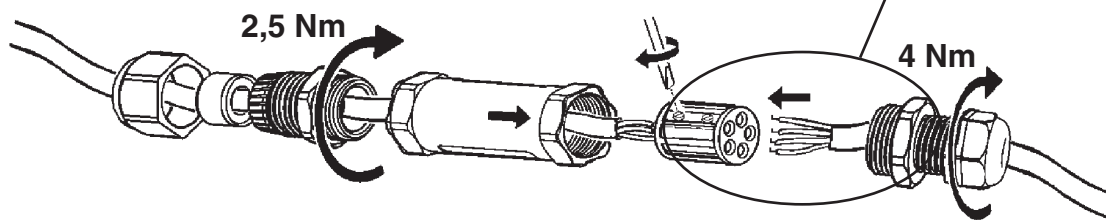
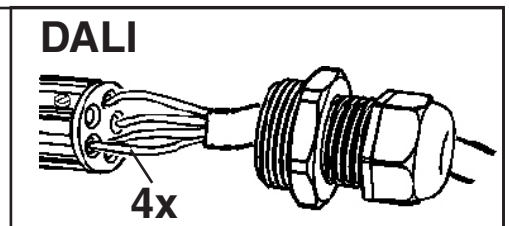
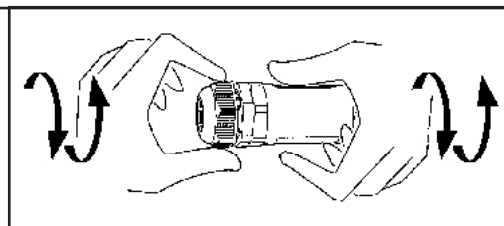

D (mm)	
8 ÷ 11 mm	
11 ÷ 17 mm	

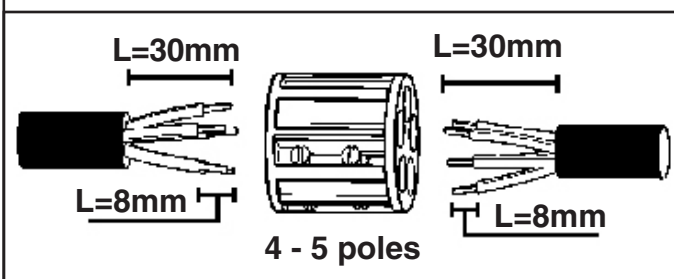

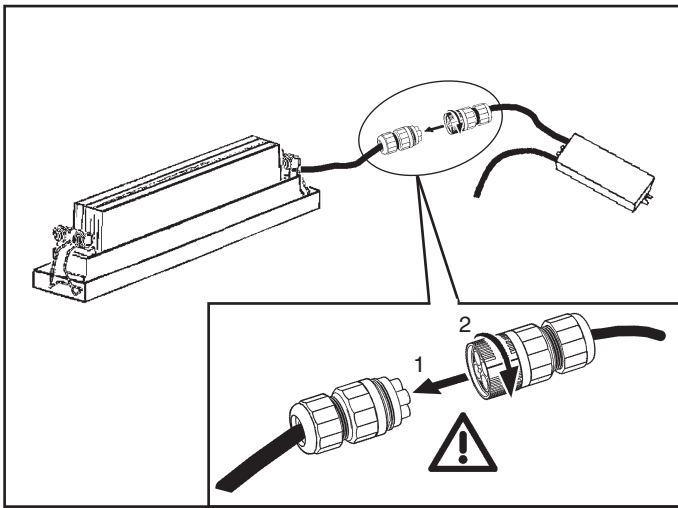

- I Cablare alla rete elettrica il trasformatore solo dopo aver effettuato il collegamento ai prodotti
- GB Wire the transformer to the electrical mains only after the connection to the products has been carried out
- F N'effectuer le câblage au réseau électrique qu'après avoir effectué le raccordement aux produits
- D Schließen Sie den Transformator erst nach der Verdrahtung an den Produkten am Stromnetz an.
- E Cablear el transformador a la red eléctrica sólo después de conectar los productos
- NL Verbind de transformator alleen op het elektrische net nadat u alle producten heeft aangesloten.
- DK Tilslut først transformatoren til strømforsyningsnettet, efter at have foretaget tilslutningen til produkterne.
- N Omformeren skal kun kobles til strømnettet etter at tilkoblingen til produktene er gjennomført.
- S Anslut transformatorn till elnätet först efter att anslutningen till produkterna har utförts.
- RUS Подвести кабель трансформатора к электрической сети, только после соединения с продуктами
- CN 只有连接灯具后，才可以把变压器连接到电源线上。

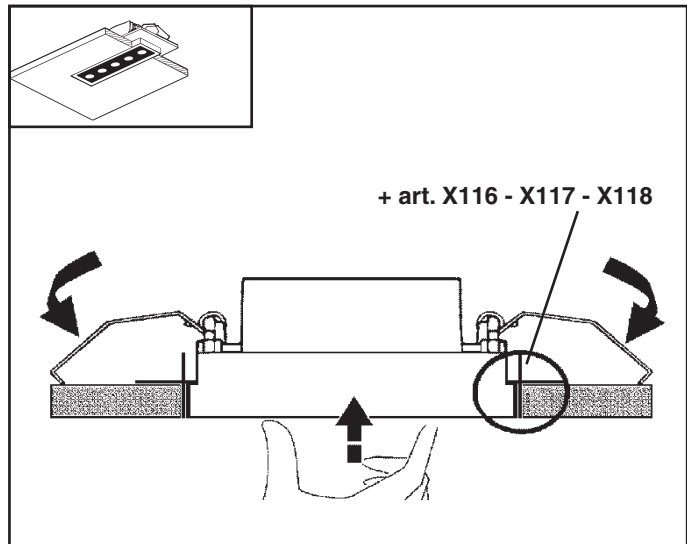
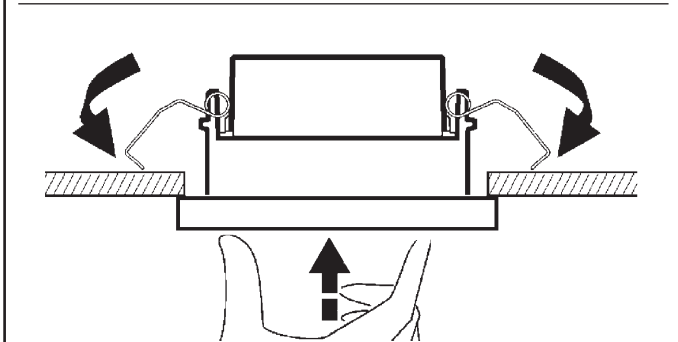
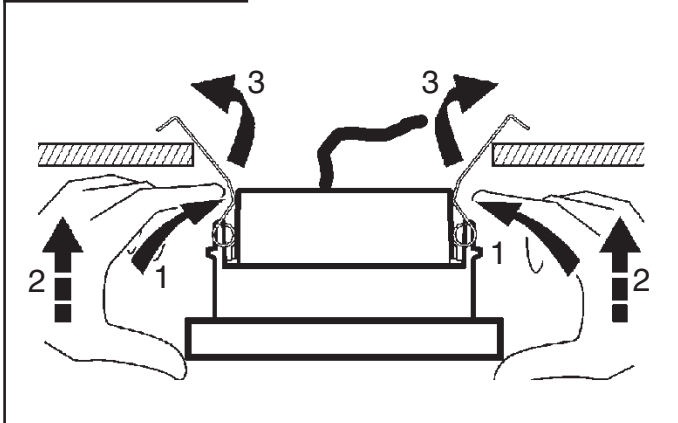

- I Per l'eventuale sostituzione del prodotto, agire come mostrato in figura.
- GB To replace the product – when necessary – proceed as illustrated in the figure.
- F Pour remplacer le produit, procédez comme illustré (voir figure).
- D Ersetzen Sie die Leuchte den Anweisungen in der Abbildung gemäß.
- NL Indien u het toestel wenst te vervangen, gelieve te werk te gaan zoals aangegeven op de afbeelding.
- E Para la eventual sustitución del producto, operar tal y como se muestra en la figura.
- DK For at udskifte produktet skal man gøre som vist i figuren.
- N For å erstatte produktet - ved behov - gå frem slik som vist på figuren.
- S Följ anvisningarna i figuren om utrustningen måste öppnas. För att byta ut produkten, vid behov, följ anvisningarna enligt figuren.
- RUS Порядок замены прибора показан на схеме.
- CN 如有需要更换产品，如图所示进行操作。

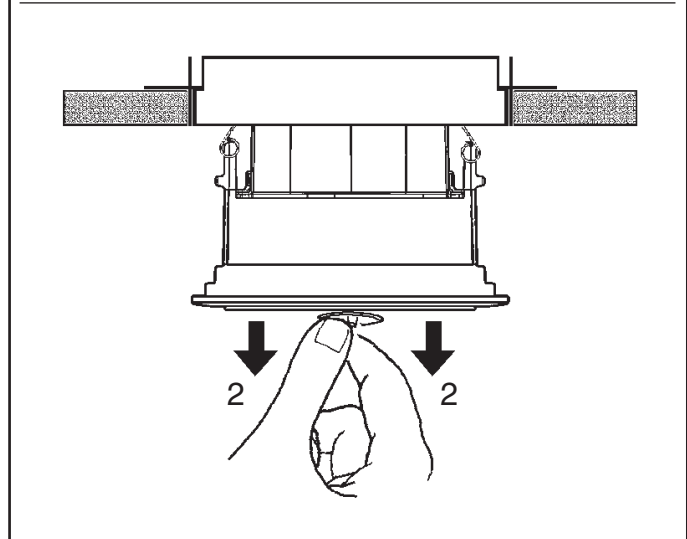
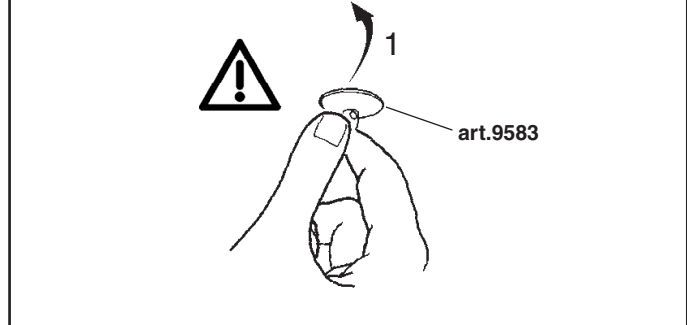
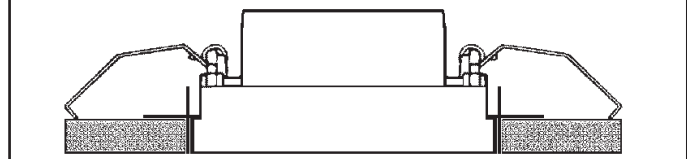

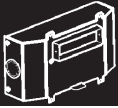

+ ART. X112 - X113 - X114

FRAME

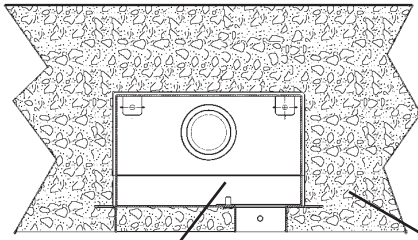

CALCESTRUZZO
CONCRETE
BETON
BETON
CEMENT
HORMIGÓN
BETON
BETONG
BETONG
БЕТОН
混凝土

CONTROCASSA
OUTER CASING
CONTRE-BOTIER
EINBAUGEHÄUSE
BUIENSTE OMHULSEL
DOBLE CAJA
INDBYGNINGSELEMENT
YTRE HUS
HÖLJE
МОНТАЖНЫЙ
调光器

MINIMAL

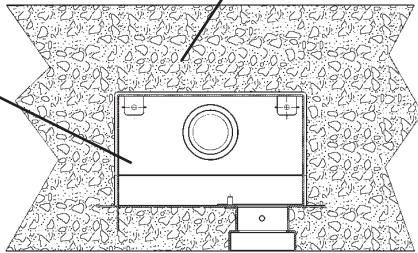

ART.

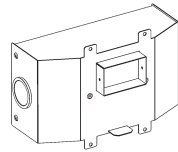

5x

X112

10x

X113

15x

X114

I Le prestazioni e la sicurezza dell'apparecchio sono garantite soltanto per oscillazioni della corrente del $\pm 5\%$ rispetto al valore nominale. La conformità alla norma è garantita soltanto utilizzando alimentatori iGuzzini.

GB The performance level and safety of the lighting fixture are only guaranteed for oscillations of $\pm 5\%$ in the current, in relation to the nominal value. Conformity with the standard is guaranteed only if either iGuzzini ballasts.

F Les performances et la sécurité de l'appareil ne sont assurées que pour des oscillations de courant de $\pm 5\%$ par rapport à la valeur nominale. La conformité à la norme n'est assurée qu'en cas d'utilisation de ballasts iGuzzini.

D Die Leistungen und die Sicherheit des Geräts sind nur für vom Vorschaltgerät abgehende Spannungsschwankungen von $\pm 5\%$ in Bezug auf den Nennwert gewährleistet. Die Übereinstimmung mit den Vorschriften ist nur bei Verwendung von iGuzzini-Netzteilen

NL De prestaties en de veiligheid van het apparaat zijn alleen gegarandeerd voor spanningsvariaties van $\pm 5\%$ ten opzichte van de nominale waarde. De conformiteit aan de norm wordt alleen gegarandeerd als u iGuzzini voorschakelapparaten gebruikt

E Las prestaciones y la seguridad del aparato están garantizada solamente con oscilaciones de la corriente del $\pm 5\%$ respecto al valor nominal. La conformidad a la norma se garantiza solamente con el uso de alimentadores iGuzzini

DK Armaturets ydelse og sikkerhed kan kun garanteres ved strømudsving på $\pm 5\%$ i forhold til den nominelle værdi. Opfyldelse af reglerne garanteres kun ved brug af strømforsyningseenheder fra iGuzzini.

N Ytelsesnivået og sikkerheten til lysarmaturen kan kun garanteres for svingninger på $\pm 5\%$ i strømmen, i forhold til nominell verdi. Samsvar med forskriften garanteres bare ved bruk av transformatorer fra iGuzzini.

S Utrustningens prestanda och säkerhet garanteras endast vid en strömoscillation på $\pm 5\%$ i förhållande till nominell värde. Överensstämmelse med standard garanteras endast genom att använda nätaggregat av typ iGuzzini.

RUS Эксплуатационные качества и безопасность прибора гарантируются только при колебаниях тока $\pm 5\%$ от номинального значения. Соответствие нормативу гарантируется только при использовании трансформаторов iGuzzini.

CN 只有在电流的额定值 $\pm 5\%$ 的情况，才可以保证装置的使用性能及安全性
只有在使用iGuzzini.

I Per progetti d'impianto personalizzati l'azienda iGuzzini fornisce, previa documentazione necessaria, i dati relativi al numero dei prodotti installabili e la lunghezza dei cavi, in funzione dell'alimentatore e del tipo di cavo utilizzato.

GB For customised installation projects iGuzzini is able to supply - accompanied by the necessary documentation - the details of the number of installable products and the length of the cables based on the ballast and type of cable used.

FR Pour des projets d'installation personnalisés, veuillez transmettre la documentation nécessaire à l'entreprise iGuzzini, qui s'occupera d'indiquer le nombre de produits à installer ainsi que la longueur des câbles, en fonction du ballast et du type de câble utilisés.

DE Für personalisierte Anlagenprojekte liefert das Unternehmen iGuzzini nach Vorlage der erforderlichen Dokumentation die Angaben bezüglich der Anzahl der installierbaren Leuchten sowie die Kabellänge in Abhängigkeit vom Vorschaltgerät und von der Art des verwendeten Kabels.

NL Na ontvangst van het benodigde documentatiemateriaal kan het bedrijf iGuzzini bij gepersonaliseerde installatie-ontwerpen informatie verschaffen betreffende het aantal installeerbare producten en de lengte van de kabels voor het voorschakelapparaat, aan de hand van het type kabel wat gebruikt zal worden.

E Para proyectos personalizados y previo conocimiento de la documentación necesaria, iGuzzini puede suministrar datos sobre el número de productos a instalar y la longitud de los cables en función de alimentador y tipo de cable utilizado.

DK Ved skræddersyede anlæg fremsender iGuzzini dokumentation med alle oplysninger vedrørende antallet af produkter, der kan installeres, og kabellængde, alt efter typen af strømforsyning og kabel.

N For spesiiltilpassede installasjonsprosjekter er iGuzzini i stand til å levere - sammen med den nødvendige dokumentasjonen - detaljene på installerbare produkter og lengden på kablene basert på ballast og type kabel som brukes.

S För kundpassade installationer tillhandahåller iGuzzini (efter nödvändig dokumentation) data angående antalet produkter som kan installeras och kablarnas längd, beroende på typen av strömförsörjningsanordning och kabel som används.

RUS Для индивидуальных проектов осветительных систем, после получения всей необходимой документации заказчика, Компания iGuzzini предоставляет сведения о количестве изделий, которые могут быть установлены, и о длине проводов в зависимости от блока питания и от типа используемого провода.

CN 对于iGuzzini公司个性化的装配系统设计，根据所使用的供电器材以及电线的种类，提供有关文件，安装的产品数据以及电线的长度。

ART.	CARICO DALI / DALI LOAD CHARGE DALI (COURANT MAXI ADMISSIBLE) DALI-LAST DALI VERMOGEN CARGA DALI DALI STRÖMSTYRKE BELASTNING FOR "DALI" DALI-BELASTNING МАКС. ТОК СИСТЕМЫ DALI С РЕГУЛЯЦИЕЙ ИНТЕНСИВНОСТИ СВЕТА DALI 智能调光系统允许的最大电流量	INDIRIZZI DALI DALI ADDRESSES ADDRESSES DALI DALI-ADRESSEN DALI ADRESSEN DIRECCIONES DALI DALI ADDRESSER ADDRESSER TIL "DALI" DALI-ADDRESSER ЛОГИЧЕСКИЕ АДРЕСА СИСТЕМЫ DALI DALI智能调光系统计算机指定控制参数
5X	1 (2 m A)	1
10X		
15X		



N.B.: DURANTE L'INSTALLAZIONE DEL SISTEMA "LASER BLADE" RISPETTARE SCRUPOLOSAMENTE LE NORME IMPIANTISTICHE NAZIONALI VIGENTI.

N.B.: WHEN INSTALLING THE "LASER BLADE" SYSTEM, MAKE SURE ALL CURRENT NATIONAL REGULATIONS RELATING TO INSTALLATION ARE OBSERVED.

N.B.: LORS DE L'INSTALLATION DU SYSTÈME "LASER BLADE" VEUILLEZ RESPECTER RIGOREUSEMENT LES NORMES EN VIGUEUR EN LA MATIÈRE DANS LE PAYS.

N.B.: BEACHTEN SIE BEI DER INSTALLATION DES SYSTEMS "LASER BLADE" UNBEDINGT DIE IM LAND GELTENDEN ANLAGETECHNISCHEN VORSCHRIFTEN.

N.B.: BIJ HET INSTALLEREN VAN HET "LASER BLADE" SYSTEEM MOET U DE GELDENDE NATIONALE INSTALLATIENORMEN STRIKT NALEVEN.

NOTA: DURANTE LA INSTALACIÓN DEL SISTEMA "LASER BLADE" RESPETAR ESCRUPULOSAMENTE LAS NORMAS NACIONALES DE INSTALACIÓN EN VIGOR.

N.B.: UNDER INSTALLATION AF "LASER BLADE" SYSTEMET SKAL MAN NØJE OVERHOLDE DE GÆLDENDE REGLER FOR DISSE ANLÆG.

N.B.: UNDER INSTALLASJON AV SYSTEMET "LASER BLADE" MÅ DE NASJONALE ANLEGGSFORSKRIFTENE OVERHOLDES NØYE.

OBS! UNDER INSTALLATIONEN AV SYSTEMET "LASER BLADE" SKA GÅLLANDE NATIONALE INSTALLATIONSFÖRESKRIFTER RESPEKTERAS I DETALJ.

ПРИМЕЧАНИЕ: В ПРОЦЕССЕ МОНТАЖА СИСТЕМЫ "LASER BLADE" СТРОГО СОБЛЮДАЙТЕ НАЦИОНАЛЬНЫЕ ДЕЙСТВУЮЩИЕ НОРМАТИВЫ ПО ЭЛЕКТРОПРОВОДКЕ.

注意：安装"LASER BLADE"系统时请务必遵守系统标准。

SOSTITUZIONE DEL LED
REPLACING THE LED
REPLACEMENT DE LA LED
AUSTAUSCHEN DER LED
VERVANGEN VAN DE LED
REEMPLAZO DEL LED
UDSKIFTNING AF LYSDIODE
BYTE AV LYSDIOD
UTSKIFTING AV DEN LYSEMITTERENDE DIODEN
Замена светодиода
发光二极管替换

I N.B.: Per la sostituzione del LED contattare l'azienda iGuzzini.
GB N.B.: For information on LED replacement please contact iGuzzini.
F N.B.: Pour procéder au remplacement de la LED, adressez-vous à la société iGuzzini.
D N.B.: Bezüglich des Austausches der LED kontaktieren Sie bitte die Firma iGuzzini.
NL N.B.: Voor het vervangen van de LED neemt u contact op met het bedrijf iGuzzini.
E NOTA: Para sustituir el LED llame a la empresa iGuzzini.
DK N.B.: For udsiftning af lysdioden, skal man kontakte iGuzzini.
N N.B.: For informasjon om skifte av LED, vennligst ta kontakt med iGuzzini.
S OBS! För byte av lysdioden, kontakta företaget iGuzzini.
RUS ПРИМЕЧАНИЕ: Для замены СИДов обращайтесь в компанию iGuzzini.
CN 注意：如需LED更换的信息，请联系iGuzzini。

LASER BLADE IN OUT 5x / 10x / 15x

MINIMAL

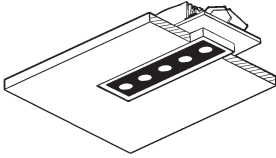

FRAME

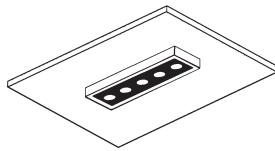

تَحذِير :

لا يمكن ضمان سلامة هذا الجهاز إلا إذا التزمت بهذه التعليمات. يجب حفظها في مكان آمن.

ATTENZIONE:
LA SICUREZZA DELL'APPARECCHIO E' GARANTITA SOLO CON L'USO APPROPRIATO DELLE SEGUENTI ISTRUZIONI; PERTANTO E' NECESSARIO CONSERVARLE.

WARNING:
THE SAFETY OF THIS FIXTURE IS GUARANTEED ONLY IF YOU COMPLY WITH THESE INSTRUCTIONS; REMEMBER TO CONSERVE IN A SAFE PLACE.

ATENCION:
LA SEGURIDAD DEL APARATO SE GARANTIZA SOLO CUMPLIENDO CUIDADOSAMENTE LAS SIGUIENTES INSTRUCCIONES; POR ELLO, ES NECESARIO CONSERVARLAS.

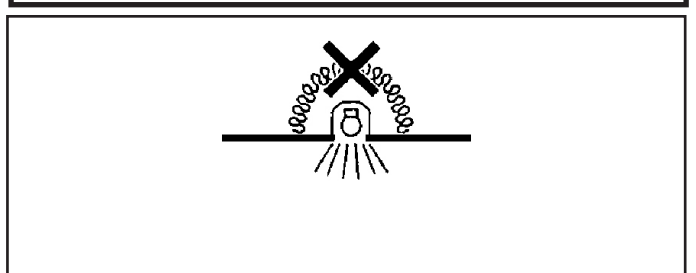
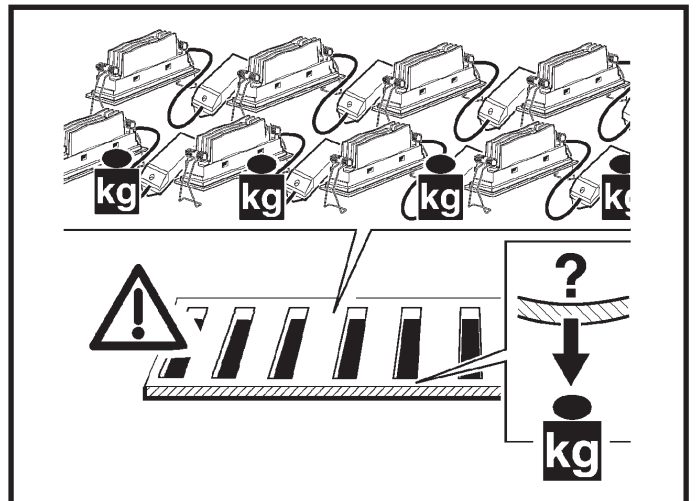
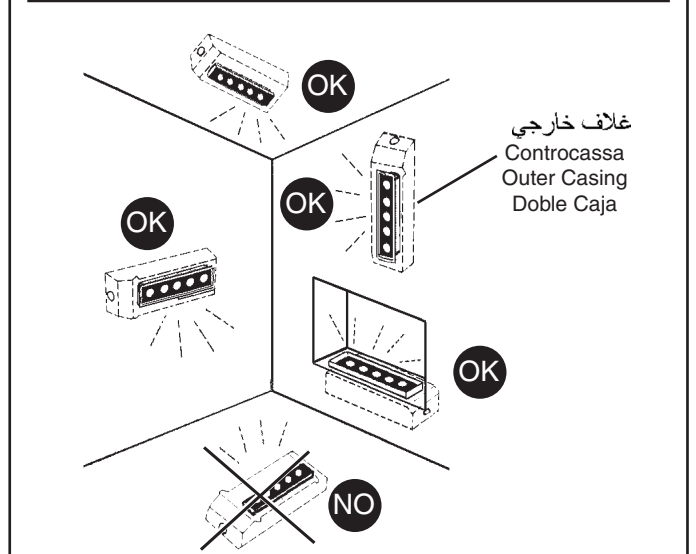
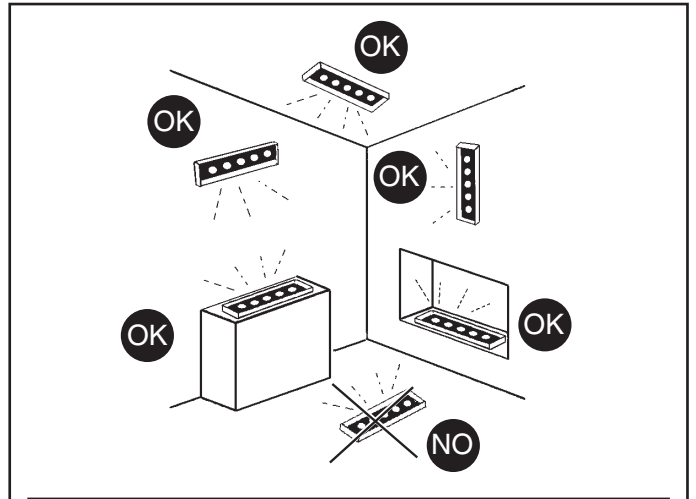

يجب عدم تغطية الجزء المركب، بأي حال من الأحوال، بمواد عازلة أو ما شابه ذلك.

I N.B.: L'apparecchio non deve, in alcuna circostanza, essere coperto con materiale isolante o similare.

GB N.B.: The fixture must not be covered, under any circumstances, by insulating materials or the like.

E NOTA: El aparato no debe ser protegido con material aislante o parecido, por ninguna causa.

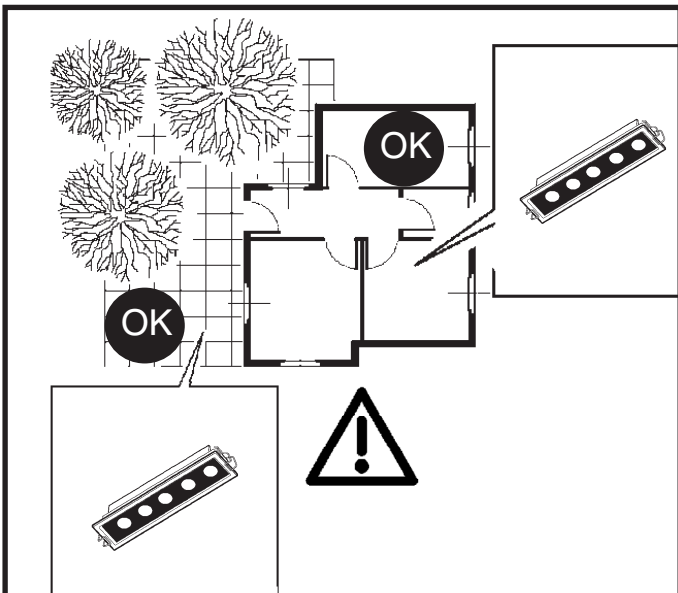
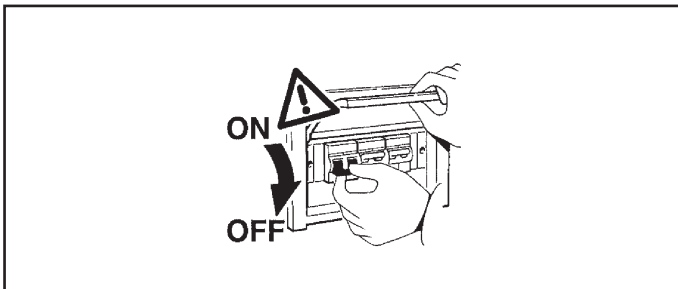

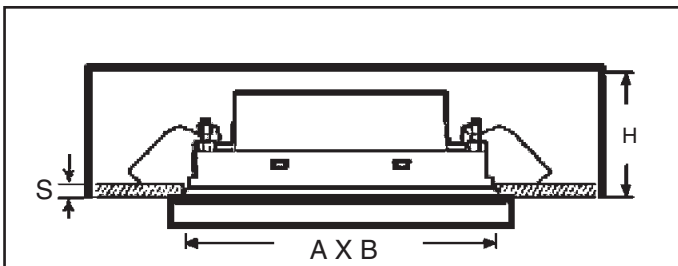
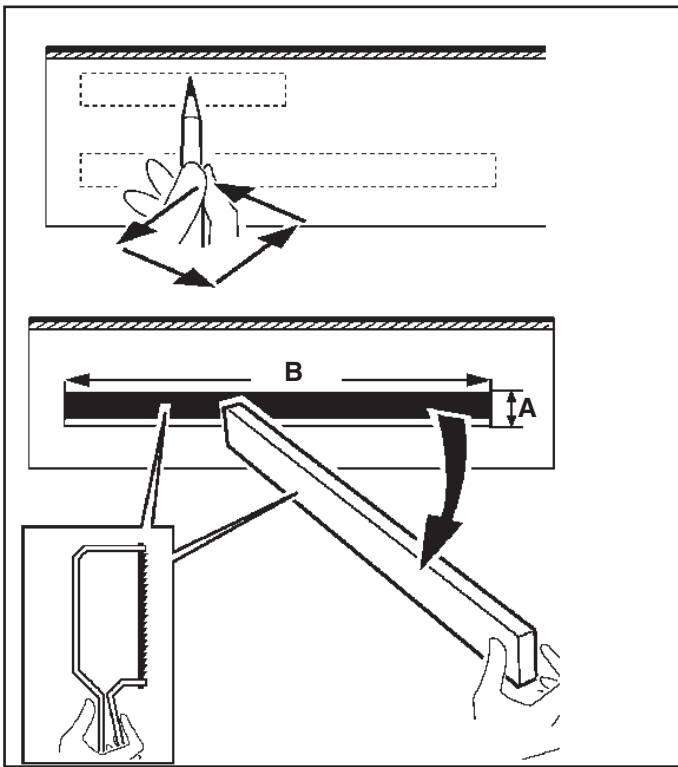

IP65

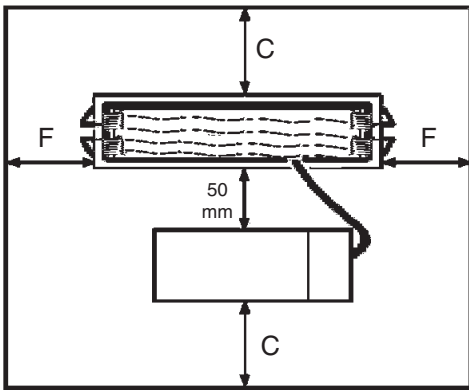

الصنف ART.	ملم A X B mm +2 -0	ملم C mm	ملم F mm	ملم H mm	ملم S mm
BX58 - BX59 - BX60 BX61 - BX62 - BX63 BX64 - BX65 - BX66 BX67	37 X 141	60	60	100	1-25
BX68 - BX69 - BX70 BX71 - BX72 - BX73 BX74 - BX75 - BX76 BX77	37 X 274	185	85		
BX78 - BX79 - BX80 BX81 - BX82 - BX83 BX84 - BX85 - BX86 BX87	37 X 406	235	85		

الصنف ART.	الصنف +ART.	ملم A x B mm +2 -0	ملم C mm	ملم F mm	ملم H mm	ملم S mm
BX58 - BX59 - BX60 BX61 - BX62 - BX63 BX64 - BX65 - BX66 BX67	+ X116	56X164	60	60	115	12,5/15
BX68 - BX69 - BX70 BX71 - BX72 - BX73 BX74 - BX75 - BX76 BX77	+ X117	56X297	185	85	115	12,5/15
BX78 - BX79 - BX80 BX81 - BX82 - BX83 BX84 - BX85 - BX86 BX87	+ X118	56X430	235	85	115	12,5/15

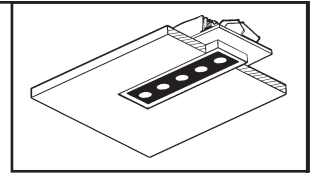

الصنف ART.	الصنف +ART.
5x	X116
10x	X117
15x	X118

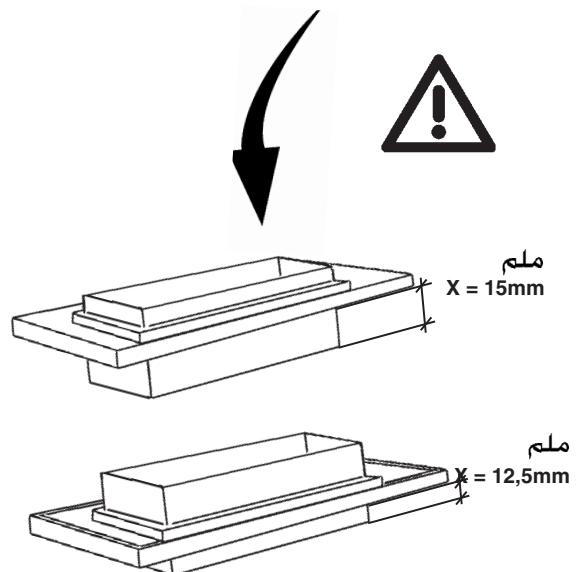
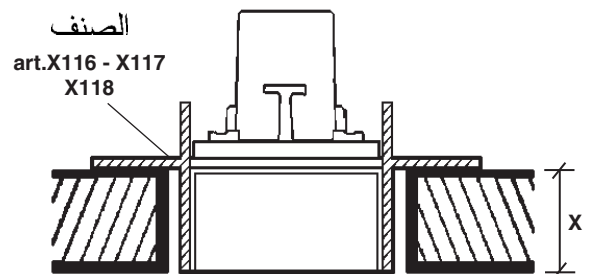

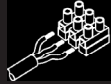
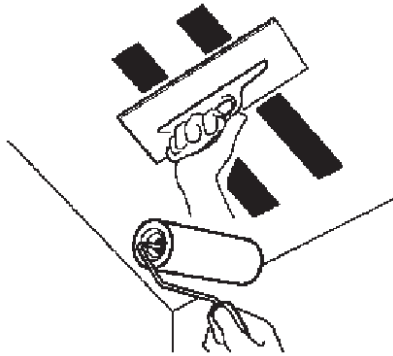
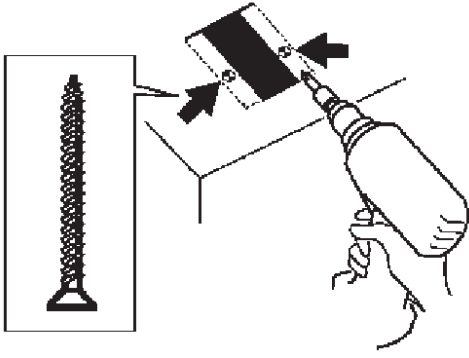

علحوظة هامة: عبوة الأقطاب غير مرفقة (مرحلة A). قد يتطلب التركيب تدخل أشخاص مؤهلين.

- I Morsetti non inclusa. L'installazione può richiedere l'intervento di personale qualificato
- GB Terminal board not included. The aid of qualified personnel may be required for installation
- E Clema de conexiones no incluida. La instalación puede necesitar la intervención de personal calificado.

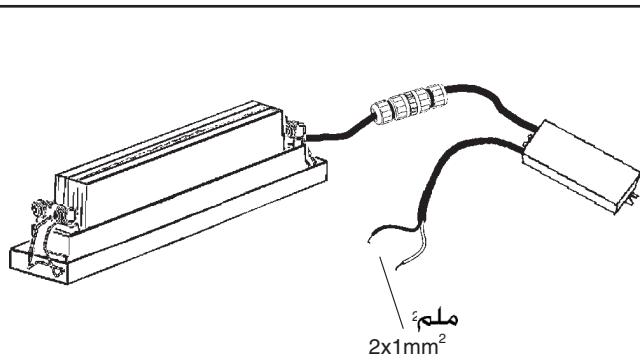

DALI

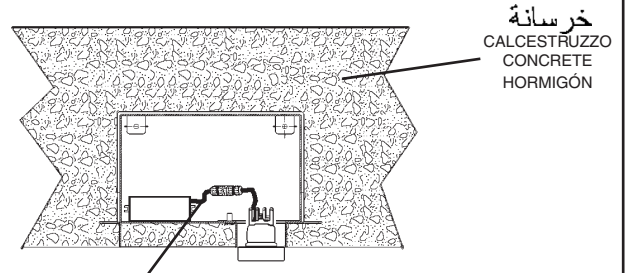
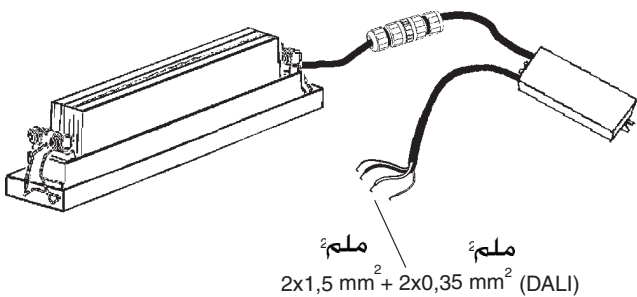

غلاف خارجي
Controcassa
Outer Casing
Doble Caja

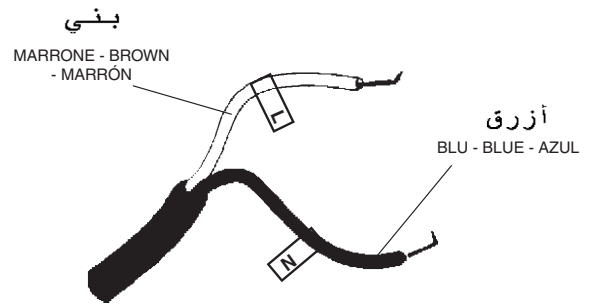

DALI

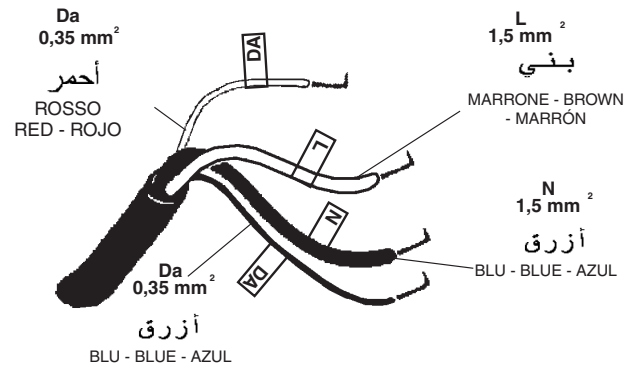

BZK6

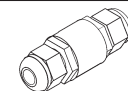

2X

BZG8

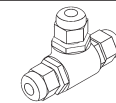

2X

BZS6

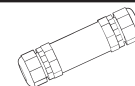

4X

BZN7

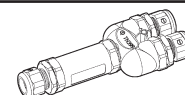

4X

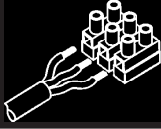

art. BZK6 - BZG8

كابح
ALIMENTATORE
BALLAST
ALIMENTADOR

الصف
art. BZK6

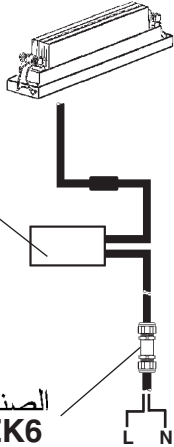

كابح
ALIMENTATORE
BALLAST
ALIMENTADOR

الصف
art. BZG8

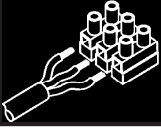
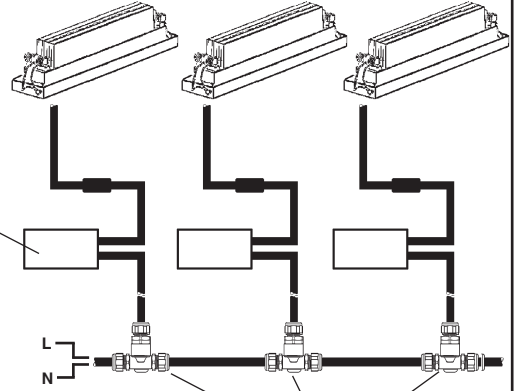

art. BZS6 - BZN7 (DALI)

كابح
ALIMENTATORE
BALLAST
ALIMENTADOR

الصف
art. BZS6 (DALI)

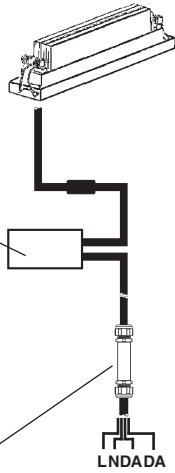

كابح
ALIMENTATORE
BALLAST
ALIMENTADOR

الصف
art. BZN7 (DALI)

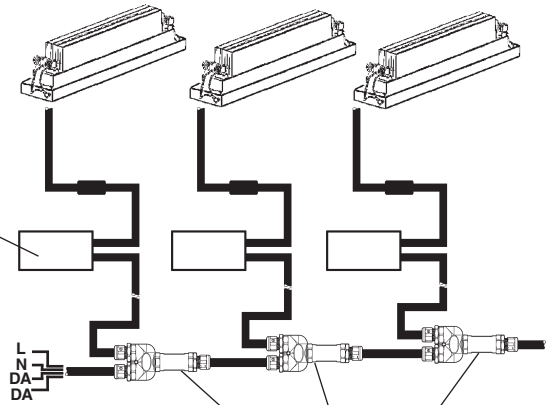

art. BZK6 الصنف
BZG8

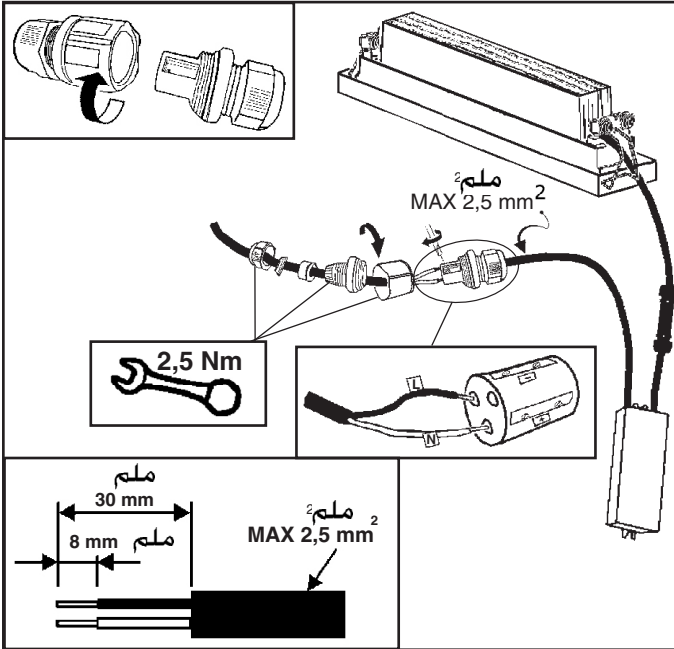

D (mm) 6,5 ÷ 8 ملم	
8 ÷ 9 ملم	
9 ÷ 13 ملم	

art. BZS6

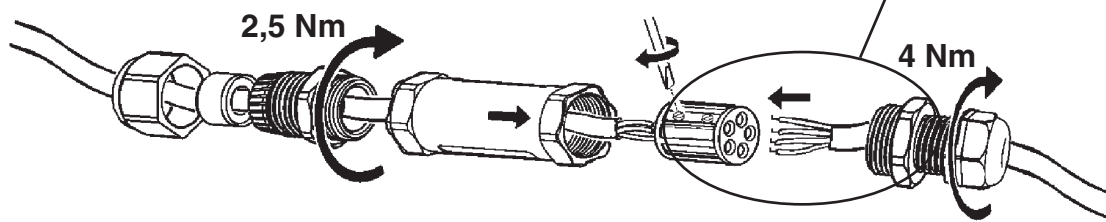
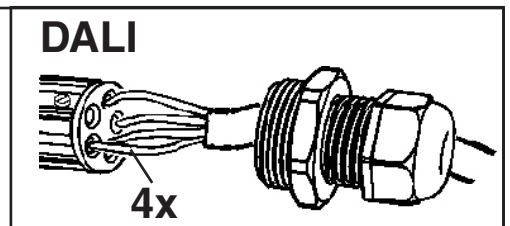
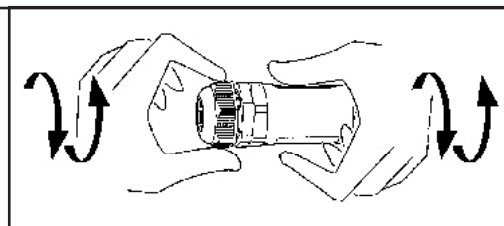

D (mm) 8 ÷ 11 mm	
11 ÷ 17 mm	

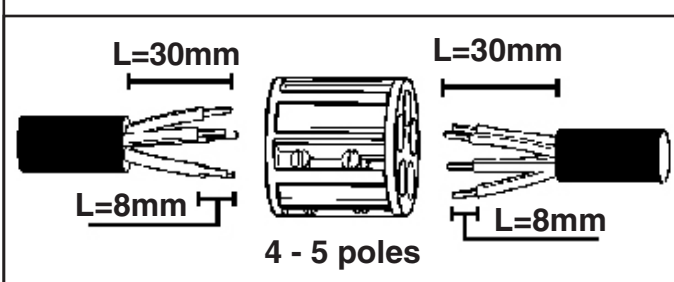

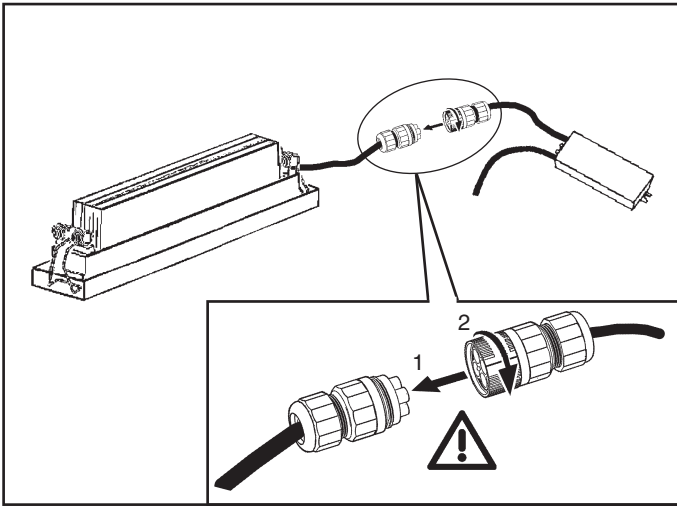

عر أوصل المحوّل بالشبكة الكهربيّة فقط بعد توصيل المنتجات.

- I Cablare alla rete elettrica il trasformatore solo dopo aver effettuato il collegamento ai prodotti
- GB Wire the transformer to the electrical mains only after the connection to the products has been carried out
- E Cablear el transformador a la red eléctrica sólo después de conectar los productos

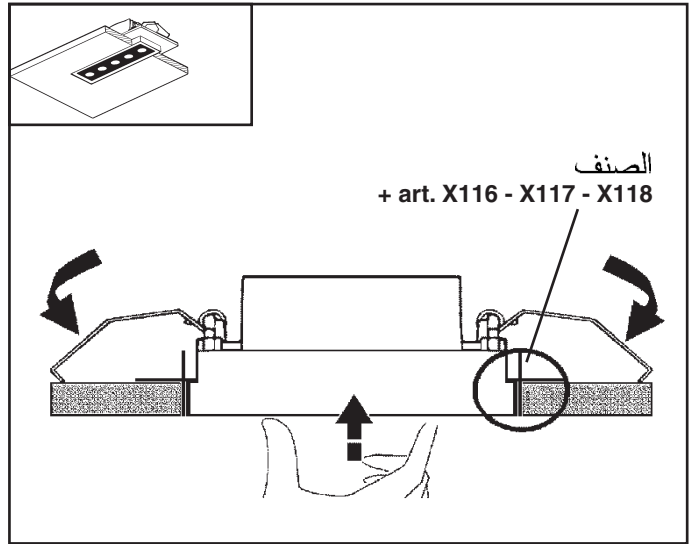
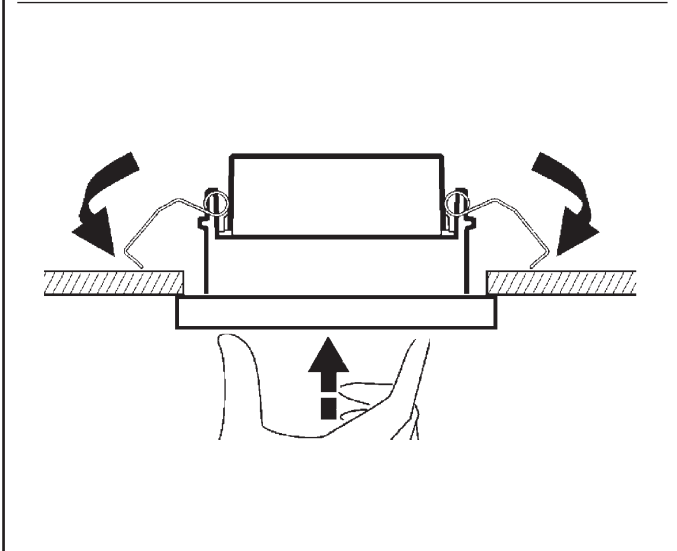
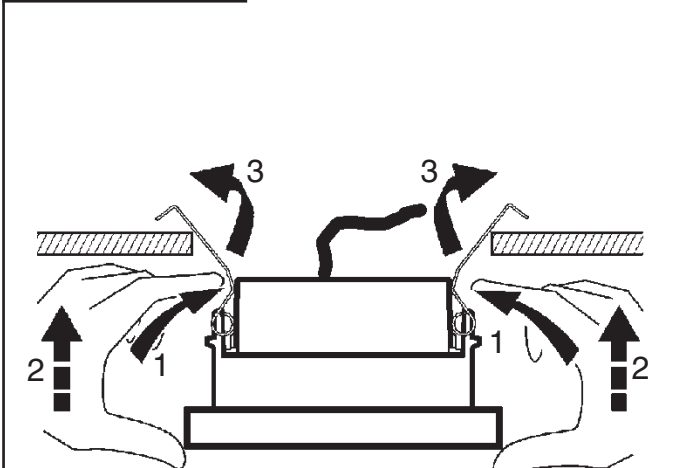

عر يُرجى التصرف كما هو مبين بالشكل؛ وذلك في حالة استبدال المنتج

- I Per l'eventuale sostituzione del prodotto, agire come mostrato in figura.
- GB To replace the product – when necessary – proceed as illustrated in the figure.
- E Para la eventual sustitución del producto, operar tal y como se muestra en la figura.

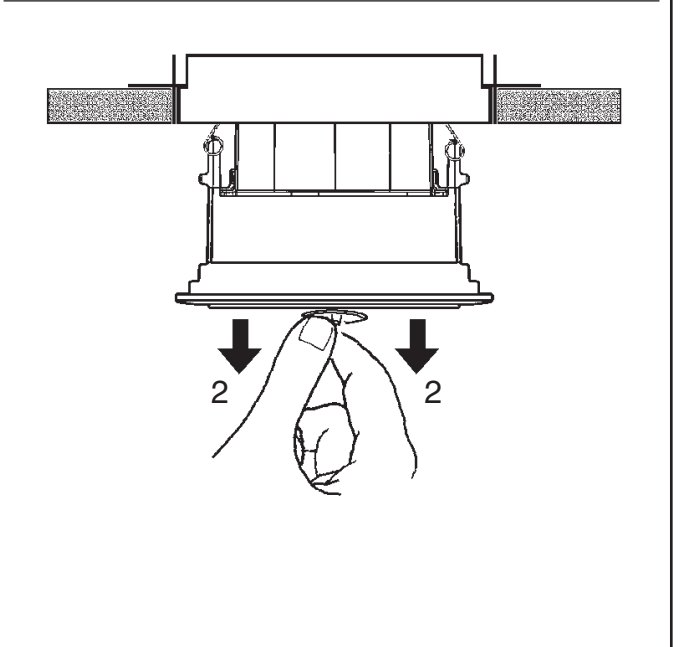
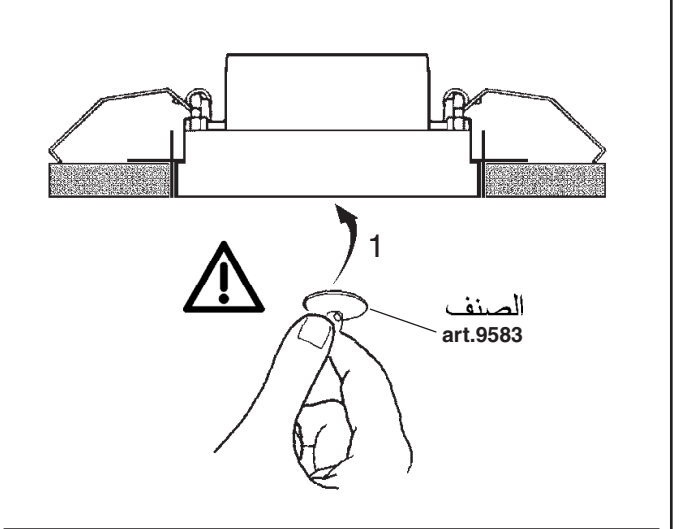
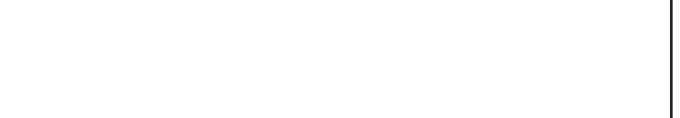
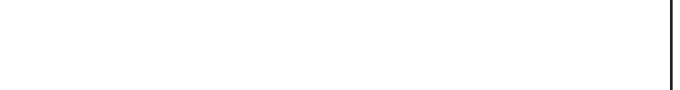

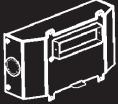

+ ART. X112 - X113 - X114

FRAME

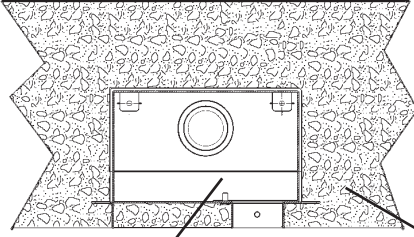

خرسانة
CALCESTRUZZO
CONCRETE
HORMIGÓN

غلاف خارجي
Controcassa
Outer Casing
Doble Caja

MINIMAL

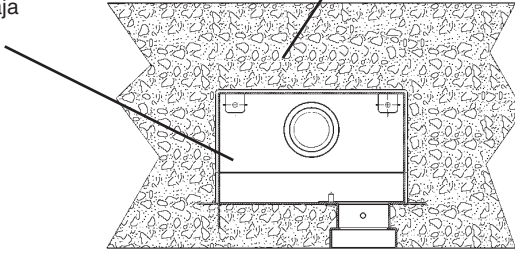

الصنف ART.	DALI ليمحت CARICO DALI / DALI LOAD CHARGE DALI CARGA DALI	DALI نيوانع INDIRIZZI DALI DALI ADDRESSES DIRECCIONES DALI
5X	1 (2 m A)	1
10X		
15X		



ملاحظة: ملاحظة: أثناء تركيب نظام LASER BLADE يجب التقيد بحرص بالنظم السائدة المتعلقة بالشبكة الكهربائية.

N.B.: DURANTE L'INSTALLAZIONE DEL SISTEMA "LASER BLADE" RISPETTARE SCRUPOLOSAMENTE LE NORME IMPIANTISTICHE VIGENTI.

N.B.: WHEN INSTALLING THE SYSTEM "LASER BLADE", STRICTLY COMPLY WITH ALL REGULATIONS ON INSTALLATION IN FORCE.

N.B.: DURANTE LA INSTALACIÓN DEL SISTEMA "LASER BLADE" RESPETAR ESCRUPULOSAMENTE LAS NORMAS DE INSTALACIÓN VIGENTES.

استبدال الضوء LED

SOSTITUZIONE DEL LED
REPLACING THE LED
REEMPLAZO DEL LED

تنبيه: لاستبدال الضوء LED اتصل بشركة iGuzzini .

I N.B.: Per la sostituzione del LED contattare l'azienda iGuzzini.

GB N.B.: For information on LED replacement please contact iGuzzini.

E NOTA: Para sustituir el LED llame a la empresa iGuzzini.

الصنف
ART.

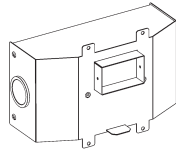

5x

X112

10x

X113

15x

X114

يتم ضمان عمل الجهاز بشكل جيد من خلال تأرجح فلتية التغذية الخارجة بنسبة $\pm 5\%$ مقارنة مع القيمة الاسمية.

يتم ضمان احترام المعايير السائدة فقط من خلال استعمال مهايئات من صنع شركة iGuzzini.

I Le prestazioni e la sicurezza dell'apparecchio sono garantite soltanto per oscillazioni della corrente del $\pm 5\%$ rispetto al valore nominale.

La conformità alla norma è garantita soltanto utilizzando alimentatori iGuzzini.

GB Optimum operating condition for the fitting is ensured only if the oscillations of the ballast output voltage are $\pm 2\%$ the nominal value.

Compliance with the regulation is ensured only if either iGuzzini transformers.

F Las condiciones de funcionamiento optimales del aparato se garantizan solamente con oscilaciones de la tensión de salida del alimentador de $\pm 2\%$ respecto al valor nominal.

La conformidad a la norma se garantiza solamente con el uso de transformadores iGuzzini.

بخصوص مشاريع الأجهزة الخاصة، تورد شركة iGuzzini بعد حصولها على الوثائق اللازمة، المعلومات المتعلقة بعدد المنتجات القابلة للتركيب وطول الكابلات الكهربائية، بناء على وحدة التغذية الكهربائية ونوع الكبل المستخدم.

I Per progetti d'impianto personalizzati l'azienda iGuzzini fornisce, previa documentazione necessaria, i dati relativi al numero dei prodotti installabili e la lunghezza dei cavi, in funzione dell'alimentatore e del tipo di cavo utilizzato.

GB For customised installation projects iGuzzini is able to supply - accompanied by the necessary documentation - the details of the number of installable products and the length of the cables based on the ballast and type of cable used.

E Para proyectos personalizados y previo conocimiento de la documentación necesaria, iGuzzini puede suministrar datos sobre el número de productos a instalar y la longitud de los cables en función de alimentador y tipo de cable utilizado.

1.154.653.00
ISO8370/03

iGuzzini

SOSTITUZIONE DEL LED
REPLACING THE LED
REEMPLACEMENT DE LA LED
AUSTAUSCHEN DER LED
VERVANGEN VAN DE LED
REEMPLAZO DEL LED
UDSKIFTNING AF LYSDIODE
BYTE AV LYSDIOD
UTSKIFTING AV DEN LYSEMITTERENDE DIODEN

ЗАМЕНА СИДа
发光二极管替换

- I** N.B.: Per la sostituzione del LED contattare l'azienda iGuzzini.
GB N.B.: For information on LED replacement please contact iGuzzini.
F N.B.: Pour procéder au remplacement de la LED, adressez-vous à la société iGuzzini.
D Ñ.B.: Bezüglich des Austausches der LED kontaktieren Sie bitte die Firma iGuzzini.
NL N.B.: Voor het vervangen van de LED neemt u contact op met het bedrijf iGuzzini.
E NOTA: Para sustituir el LED llame a la empresa iGuzzini.
DK N.B.: For udsiftning af lysdioden, skal man kontakte iGuzzini.
N N.B.: For informasjon om skifte av LED, vennligst ta kontakt med iGuzzini.
S OBS! För byte av lysdioden, kontakta företaget iGuzzini.
RUS ПРИМЕЧАНИЕ: Для замены СИДов обращайтесь в компанию iGuzzini.
CN 注意：如需LED更换的信息，请联系iGuzzini。

- I** L'apparecchio dovrebbe essere posizionato in modo che non sia prevista un'osservazione prolungata dell'apparecchio ad una distanza inferiore di 1 m.
GB The luminaire should be positioned so that prolonged staring into the luminaire at a distance closer than 1 m is not expected.
FR Il faudrait placer l'appareil de manière à ce qu'aucune observation prolongée de l'appareil ne soit possible à moins de 1 m de distance
D Das Gerät so positionieren, dass der Anwender nicht über längere Zeit aus weniger als 1 m Abstand angestrahlt wird.
NL Het apparaat moet zodanig geplaatst worden dat er geen langdurige observatie van het apparaat te voorzien is op een afstand van minder dan 1 m
E El aparato debe emplazarse de manera tal que la observación prolongada se realice a una distancia de al menos 1 m.
DK Apparatet skal placeres på et sted, så der ikke kræves en forlængerledning, der er længere end 1 meter
N Apparatet bør plasseres slik at man ikke behøver å se på det i lengre tid på mindre avstand enn 1 m
S Apparatet ska placeras så att det inte är möjligt att titta in i den under en längre tid på ett avstånd kortare än 1 m
RUS Прибор следует установить так, чтобы не смотреть на него продолжительное время, если расстояние не достигает 1 м.
CN 灯具应按照该种方式安置，以避免长时间在1米范围内盯着灯看。

1.154.653.00
ISO8370/03

iGuzzini

SOSTITUZIONE DEL LED
REPLACING THE LED
REEMPLACEMENT DE LA LED
AUSTAUSCHEN DER LED
VERVANGEN VAN DE LED
REEMPLAZO DEL LED
UDSKIFTNING AF LYSDIODE
BYTE AV LYSDIOD
UTSKIFTING AV DEN LYSEMITTERENDE DIODEN

ЗАМЕНА СИДа
发光二极管替换

- I** N.B.: Per la sostituzione del LED contattare l'azienda iGuzzini.
GB N.B.: For information on LED replacement please contact iGuzzini.
F N.B.: Pour procéder au remplacement de la LED, adressez-vous à la société iGuzzini.
D Ñ.B.: Bezüglich des Austausches der LED kontaktieren Sie bitte die Firma iGuzzini.
NL N.B.: Voor het vervangen van de LED neemt u contact op met het bedrijf iGuzzini.
E NOTA: Para sustituir el LED llame a la empresa iGuzzini.
DK N.B.: For udsiftning af lysdioden, skal man kontakte iGuzzini.
N N.B.: For informasjon om skifte av LED, vennligst ta kontakt med iGuzzini.
S OBS! För byte av lysdioden, kontakta företaget iGuzzini.
RUS ПРИМЕЧАНИЕ: Для замены СИДов обращайтесь в компанию iGuzzini.
CN 注意：如需LED更换的信息，请联系iGuzzini。

- I** L'apparecchio dovrebbe essere posizionato in modo che non sia prevista un'osservazione prolungata dell'apparecchio ad una distanza inferiore di 1 m.
GB The luminaire should be positioned so that prolonged staring into the luminaire at a distance closer than 1 m is not expected.
FR Il faudrait placer l'appareil de manière à ce qu'aucune observation prolongée de l'appareil ne soit possible à moins de 1 m de distance
D Das Gerät so positionieren, dass der Anwender nicht über längere Zeit aus weniger als 1 m Abstand angestrahlt wird.
NL Het apparaat moet zodanig geplaatst worden dat er geen langdurige observatie van het apparaat te voorzien is op een afstand van minder dan 1 m
E El aparato debe emplazarse de manera tal que la observación prolongada se realice a una distancia de al menos 1 m.
DK Apparatet skal placeres på et sted, så der ikke kræves en forlængerledning, der er længere end 1 meter
N Apparatet bør plasseres slik at man ikke behøver å se på det i lengre tid på mindre avstand enn 1 m
S Apparatet ska placeras så att det inte är möjligt att titta in i den under en längre tid på ett avstånd kortare än 1 m
RUS Прибор следует установить так, чтобы не смотреть на него продолжительное время, если расстояние не достигает 1 м.
CN 灯具应按照该种方式安置，以避免长时间在1米范围内盯着灯看。

1.154.653.00
ISO8370/03

iGuzzini

SOSTITUZIONE DEL LED
REPLACING THE LED
REEMPLACEMENT DE LA LED
AUSTAUSCHEN DER LED
VERVANGEN VAN DE LED
REEMPLAZO DEL LED
UDSKIFTNING AF LYSDIODE
BYTE AV LYSDIOD
UTSKIFTING AV DEN LYSEMITTERENDE DIODEN

ЗАМЕНА СИДа
发光二极管替换

- I** N.B.: Per la sostituzione del LED contattare l'azienda iGuzzini.
GB N.B.: For information on LED replacement please contact iGuzzini.
F N.B.: Pour procéder au remplacement de la LED, adressez-vous à la société iGuzzini.
D Ñ.B.: Bezüglich des Austausches der LED kontaktieren Sie bitte die Firma iGuzzini.
NL N.B.: Voor het vervangen van de LED neemt u contact op met het bedrijf iGuzzini.
E NOTA: Para sustituir el LED llame a la empresa iGuzzini.
DK N.B.: For udsiftning af lysdioden, skal man kontakte iGuzzini.
N N.B.: For informasjon om skifte av LED, vennligst ta kontakt med iGuzzini.
S OBS! För byte av lysdioden, kontakta företaget iGuzzini.
RUS ПРИМЕЧАНИЕ: Для замены СИДов обращайтесь в компанию iGuzzini.
CN 注意：如需LED更换的信息，请联系iGuzzini。

- I** L'apparecchio dovrebbe essere posizionato in modo che non sia prevista un'osservazione prolungata dell'apparecchio ad una distanza inferiore di 1 m.
GB The luminaire should be positioned so that prolonged staring into the luminaire at a distance closer than 1 m is not expected.
FR Il faudrait placer l'appareil de manière à ce qu'aucune observation prolongée de l'appareil ne soit possible à moins de 1 m de distance
D Das Gerät so positionieren, dass der Anwender nicht über längere Zeit aus weniger als 1 m Abstand angestrahlt wird.
NL Het apparaat moet zodanig geplaatst worden dat er geen langdurige observatie van het apparaat te voorzien is op een afstand van minder dan 1 m
E El aparato debe emplazarse de manera tal que la observación prolongada se realice a una distancia de al menos 1 m.
DK Apparatet skal placeres på et sted, så der ikke kræves en forlængerledning, der er længere end 1 meter
N Apparatet bør plasseres slik at man ikke behøver å se på det i lengre tid på mindre avstand enn 1 m
S Apparatet ska placeras så att det inte är möjligt att titta in i den under en längre tid på ett avstånd kortare än 1 m
RUS Прибор следует установить так, чтобы не смотреть на него продолжительное время, если расстояние не достигает 1 м.
CN 灯具应按照该种方式安置，以避免长时间在1米范围内盯着灯看。

I PERIODO GIORNALIERO DI ACCENSIONE AMMESSO
GB ALLOWED DAILY OPERATION PERIOD
F DURÉE QUOTIDIENNE D'ALLUMAGE ADMISSIBLE
D ERLAUBTE TÄGLICHE EINSCHALTDAUER
NL DAGELIJKSE ONTSTEKINGSPERIODE TOEGESTAAN
E PERIODO DIARIO DE ENCENDIDO PERMITIDO
DK TILLADT TIDSRUM FOR DAGLIG TÆNDING
N TILLÄTT TENNINGSTID PR. DAG
S TILLÄTEN DAGLIG PERIOD SOM PRODUKTEN KAN VARA TÄND
RUS ЕЖЕДНЕВНАЯ ДОПУСТИМАЯ ПРОДОЛЖИТЕЛЬНОСТЬ РАБОТЫ
CN 允许的日常运营周期

iGuzzini

1.154.627.01
 IS09175/01



I PERIODO GIORNALIERO DI ACCENSIONE AMMESSO
GB ALLOWED DAILY OPERATION PERIOD
F DURÉE QUOTIDIENNE D'ALLUMAGE ADMISSIBLE
D ERLAUBTE TÄGLICHE EINSCHALTDAUER
NL DAGELIJKSE ONTSTEKINGSPERIODE TOEGESTAAN
E PERIODO DIARIO DE ENCENDIDO PERMITIDO
DK TILLADT TIDSRUM FOR DAGLIG TÆNDING
N TILLÄTT TENNINGSTID PR. DAG
S TILLÄTEN DAGLIG PERIOD SOM PRODUKTEN KAN VARA TÄND
RUS ЕЖЕДНЕВНАЯ ДОПУСТИМАЯ ПРОДОЛЖИТЕЛЬНОСТЬ РАБОТЫ
CN 允许的日常运营周期

iGuzzini

1.154.627.01
 IS09175/01

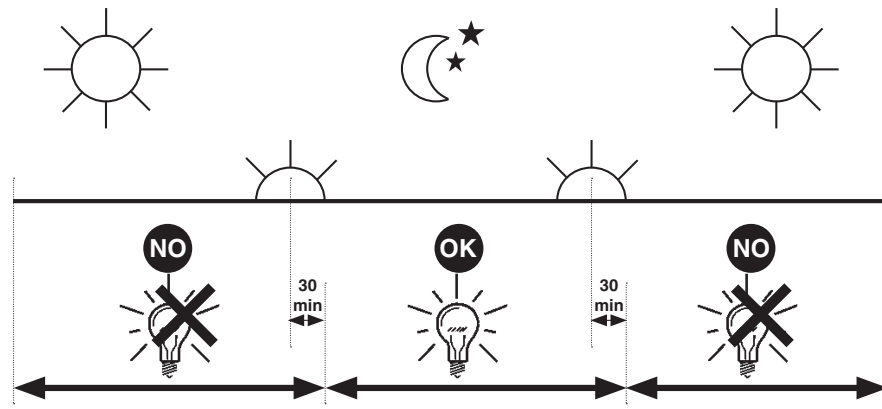

I PERIODO GIORNALIERO DI ACCENSIONE AMMESSO
GB ALLOWED DAILY OPERATION PERIOD
F DURÉE QUOTIDIENNE D'ALLUMAGE ADMISSIBLE
D ERLAUBTE TÄGLICHE EINSCHALTDAUER
NL DAGELIJKSE ONTSTEKINGSPERIODE TOEGESTAAN
E PERIODO DIARIO DE ENCENDIDO PERMITIDO
DK TILLADT TIDSRUM FOR DAGLIG TÆNDING
N TILLÄTT TENNINGSTID PR. DAG
S TILLÄTEN DAGLIG PERIOD SOM PRODUKTEN KAN VARA TÄND
RUS ЕЖЕДНЕВНАЯ ДОПУСТИМАЯ ПРОДОЛЖИТЕЛЬНОСТЬ РАБОТЫ
CN 允许的日常运营周期

iGuzzini

1.154.627.01
 IS09175/01





I PERIODO GIORNALIERO DI ACCENSIONE AMMESSO
GB ALLOWED DAILY OPERATION PERIOD
F DURÉE QUOTIDIENNE D'ALLUMAGE ADMISSIBLE
D ERLAUBTE TÄGLICHE EINSCHALTDAUER
NL DAGELIJKSE ONTSTEKINGSPERIODE TOEGESTAAN
E PERIODO DIARIO DE ENCENDIDO PERMITIDO
DK TILLADT TIDSRUM FOR DAGLIG TÆNDING
N TILLÄTT TENNINGSTID PR. DAG
S TILLÄTEN DAGLIG PERIOD SOM PRODUKTEN KAN VARA TÄND
RUS ЕЖЕДНЕВНАЯ ДОПУСТИМАЯ ПРОДОЛЖИТЕЛЬНОСТЬ РАБОТЫ
CN 允许的日常运营周期

iGuzzini

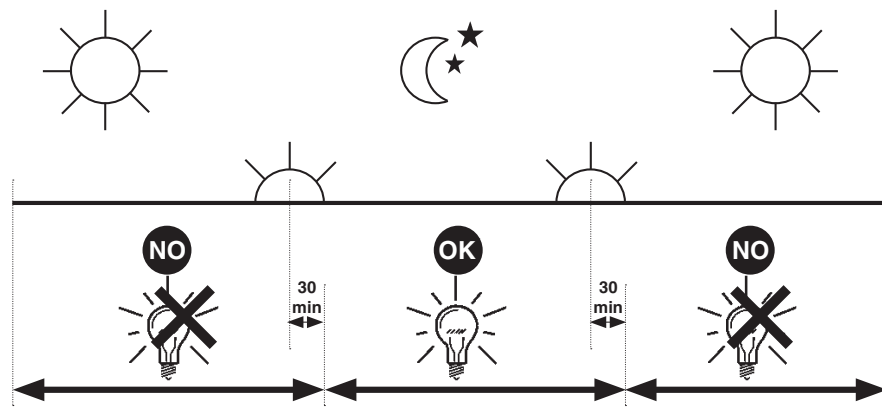
1.154.627.01
 IS09175/01



2.519.566.00 IS09266/00 	corrente assorbita absorbed current courant absorbé Stromaufnahme stroomopname corriente absorbida absorberet strøm absorbert strøm tillförd ström поглщаемая мощность 电源电流		fattore di potenza power factor facteur de puissance Leistungsfaktor vermogensfactor factor de potencia effektfaktor effektfaktor effektfaktor фактор мощности 功率因数
	ART.	A	Vf
BX55 - BX56 - BX57	0.7	6	1
BX58 - BX59 - BX60 BX61 - BX62	0.97		0.53
BX63 - BX64 - BX65 BX66 - BX67	0.063		0.85
BX68 - BX69 - BX70 BX71 - BX72	0.116		0.9
BX73 - BX74 - BX75 BX76 - BX77	0.11		
BX78 - BX79 - BX80 BX81 - BX82	0.162		
BX83 - BX84 - BX85 BX86 - BX87	0.167		

2.519.566.00 IS09266/00 	corrente assorbita absorbed current courant absorbé Stromaufnahme stroomopname corriente absorbida absorberet strøm absorbert strøm tillförd ström поглщаемая мощность 电源电流		fattore di potenza power factor facteur de puissance Leistungsfaktor vermogensfactor factor de potencia effektfaktor effektfaktor effektfaktor фактор мощности 功率因数
	ART.	A	Vf
BX55 - BX56 - BX57	0.7	6	1
BX58 - BX59 - BX60 BX61 - BX62	0.97		0.53
BX63 - BX64 - BX65 BX66 - BX67	0.063		0.85
BX68 - BX69 - BX70 BX71 - BX72	0.116		0.9
BX73 - BX74 - BX75 BX76 - BX77	0.11		
BX78 - BX79 - BX80 BX81 - BX82	0.162		
BX83 - BX84 - BX85 BX86 - BX87	0.167		

2.519.566.00 IS09266/00 	corrente assorbita absorbed current courant absorbé Stromaufnahme stroomopname corriente absorbida absorberet strøm absorbert strøm tillförd ström поглщаемая мощность 电源电流		fattore di potenza power factor facteur de puissance Leistungsfaktor vermogensfactor factor de potencia effektfaktor effektfaktor effektfaktor фактор мощности 功率因数
	ART.	A	Vf
BX55 - BX56 - BX57	0.7	6	1
BX58 - BX59 - BX60 BX61 - BX62	0.97		0.53
BX63 - BX64 - BX65 BX66 - BX67	0.063		0.85
BX68 - BX69 - BX70 BX71 - BX72	0.116		0.9
BX73 - BX74 - BX75 BX76 - BX77	0.11		
BX78 - BX79 - BX80 BX81 - BX82	0.162		
BX83 - BX84 - BX85 BX86 - BX87	0.167		

2.519.566.00 IS09266/00 	corrente assorbita absorbed current courant absorbé Stromaufnahme stroomopname corriente absorbida absorberet strøm absorbert strøm tillförd ström поглщаемая мощность 电源电流		fattore di potenza power factor facteur de puissance Leistungsfaktor vermogensfactor factor de potencia effektfaktor effektfaktor effektfaktor фактор мощности 功率因数
	ART.	A	Vf
BX55 - BX56 - BX57	0.7	6	1
BX58 - BX59 - BX60 BX61 - BX62	0.97		0.53
BX63 - BX64 - BX65 BX66 - BX67	0.063		0.85
BX68 - BX69 - BX70 BX71 - BX72	0.116		0.9
BX73 - BX74 - BX75 BX76 - BX77	0.11		
BX78 - BX79 - BX80 BX81 - BX82	0.162		
BX83 - BX84 - BX85 BX86 - BX87	0.167		

iGuzzini

2.509.386.00
ISO9176/01

الفترة الزمنية اليومية للتشغيل المسموح بها

- I PERIODO GIORNALIERO DI ACCENSIONE AMMESSO
- GB ALLOWED DAILY OPERATION PERIOD
- E PERIODO DIARIO DE ENCENDIDO PERMITIDO

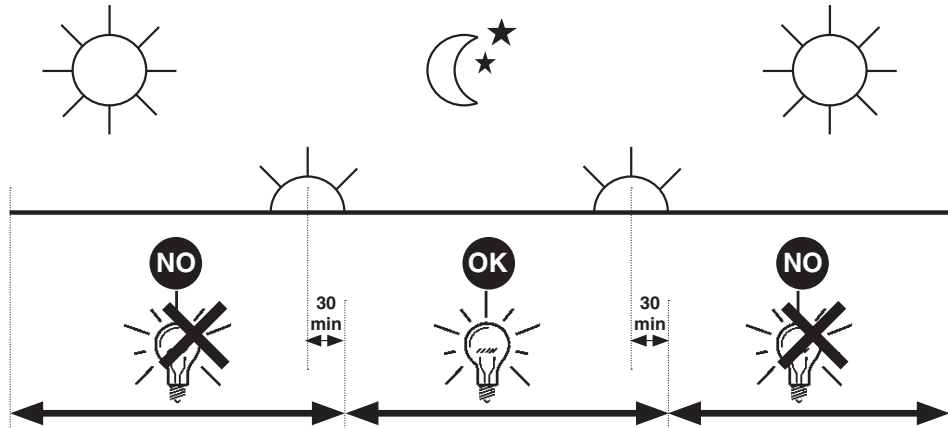

iGuzzini

2.509.386.00
ISO9176/01

الفترة الزمنية اليومية للتشغيل المسموح بها

- I PERIODO GIORNALIERO DI ACCENSIONE AMMESSO
- GB ALLOWED DAILY OPERATION PERIOD
- E PERIODO DIARIO DE ENCENDIDO PERMITIDO

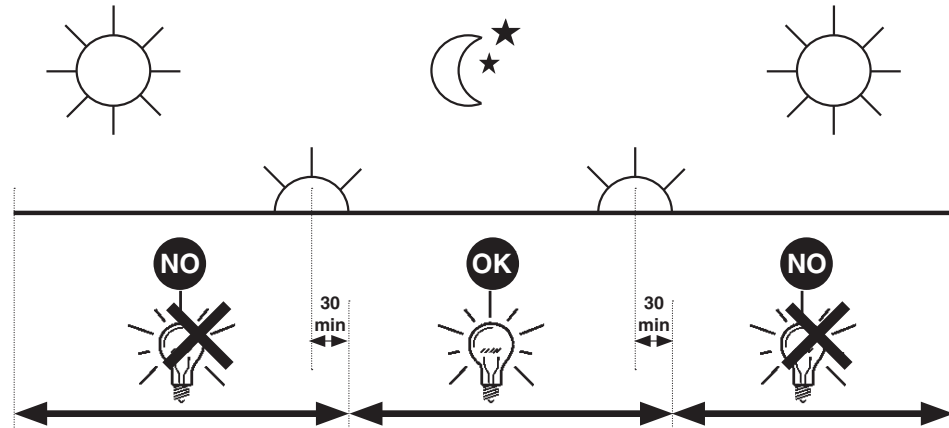

iGuzzini

2.509.386.00
ISO9176/01

الفترة الزمنية اليومية للتشغيل المسموح بها

- I PERIODO GIORNALIERO DI ACCENSIONE AMMESSO
- GB ALLOWED DAILY OPERATION PERIOD
- E PERIODO DIARIO DE ENCENDIDO PERMITIDO

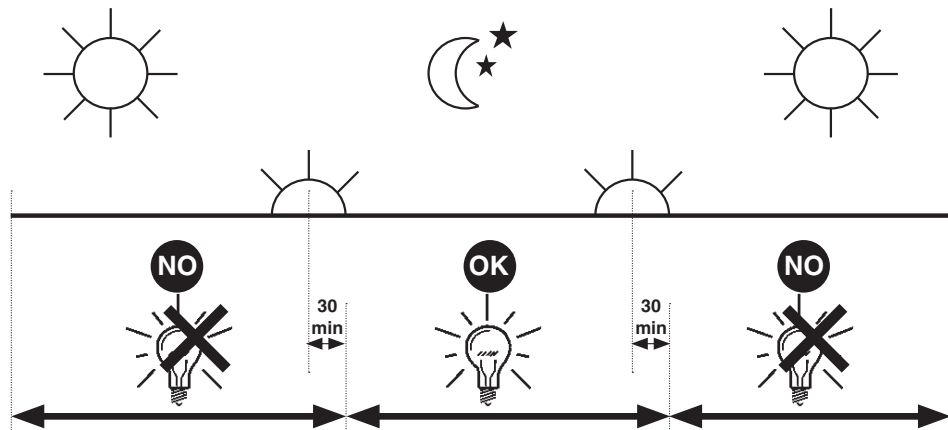

iGuzzini

2.509.386.00
ISO9176/01

الفترة الزمنية اليومية للتشغيل المسموح بها

- I PERIODO GIORNALIERO DI ACCENSIONE AMMESSO
- GB ALLOWED DAILY OPERATION PERIOD
- E PERIODO DIARIO DE ENCENDIDO PERMITIDO

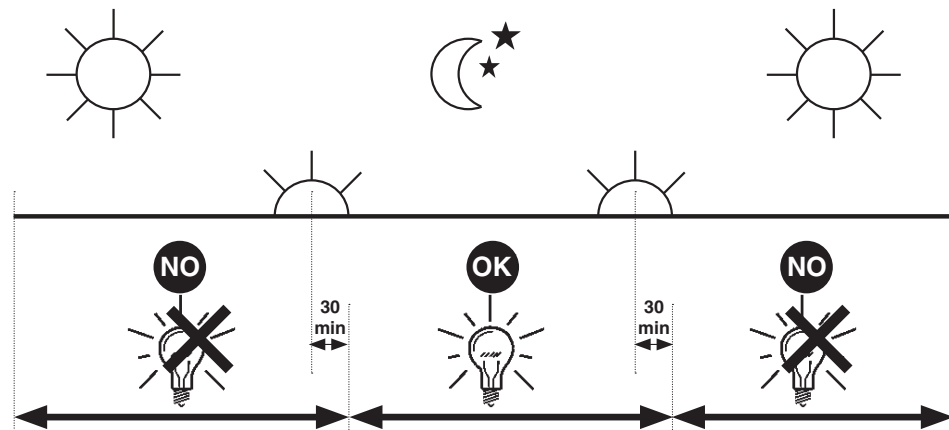

2.509.417.01
ISO9496/01

iGuzzini

استبدال الضوء LED
SOSTITUZIONE DEL LED
REPLACING THE LED
REEMPLAZO DEL LED

ملاحظة: لاستبدال الضوء، اتصل بشركة iGuzzini

I N.B.: Per la sostituzione del LED contattare l'azienda iGuzzini.

GB N.B.: For information on LED replacement please contact iGuzzini.

E NOTA: Para sustituir el LED llame a la empresa iGuzzini.

تفاسم نم، ءل يوط قرتفل زاهجلا تبقارم عقوت مدع رابتعالا
ني عب ذخوي ثي حب، زاهجلا عضو بجي رتم 1 نم لقا

I L'apparecchio dovrebbe essere posizionato in modo che non sia prevista un'osservazione prolungata dell'apparecchio ad una distanza inferiore di 1 m.

GB The luminaire should be positioned so that prolonged staring into the luminaire at a distance closer than 1 m is not expected.

E El aparato debe emplazarse de manera tal que la observación prolongada se realice a una distancia de al menos 1 m.

2.509.417.01
ISO9496/01

iGuzzini

استبدال الضوء LED
SOSTITUZIONE DEL LED
REPLACING THE LED
REEMPLAZO DEL LED

ملاحظة: لاستبدال الضوء، اتصل بشركة iGuzzini

I N.B.: Per la sostituzione del LED contattare l'azienda iGuzzini.

GB N.B.: For information on LED replacement please contact iGuzzini.

E NOTA: Para sustituir el LED llame a la empresa iGuzzini.

تفاسم نم، ءل يوط قرتفل زاهجلا تبقارم عقوت مدع رابتعالا
ني عب ذخوي ثي حب، زاهجلا عضو بجي رتم 1 نم لقا

I L'apparecchio dovrebbe essere posizionato in modo che non sia prevista un'osservazione prolungata dell'apparecchio ad una distanza inferiore di 1 m.

GB The luminaire should be positioned so that prolonged staring into the luminaire at a distance closer than 1 m is not expected.

E El aparato debe emplazarse de manera tal que la observación prolongada se realice a una distancia de al menos 1 m.

2.509.417.01
ISO9496/01

iGuzzini

استبدال الضوء LED
SOSTITUZIONE DEL LED
REPLACING THE LED
REEMPLAZO DEL LED

ملاحظة: لاستبدال الضوء، اتصل بشركة iGuzzini

I N.B.: Per la sostituzione del LED contattare l'azienda iGuzzini.

GB N.B.: For information on LED replacement please contact iGuzzini.

E NOTA: Para sustituir el LED llame a la empresa iGuzzini.

تفاسم نم، ءل يوط قرتفل زاهجلا تبقارم عقوت مدع رابتعالا
ني عب ذخوي ثي حب، زاهجلا عضو بجي رتم 1 نم لقا

I L'apparecchio dovrebbe essere posizionato in modo che non sia prevista un'osservazione prolungata dell'apparecchio ad una distanza inferiore di 1 m.

GB The luminaire should be positioned so that prolonged staring into the luminaire at a distance closer than 1 m is not expected.

E El aparato debe emplazarse de manera tal que la observación prolongada se realice a una distancia de al menos 1 m.

2.509.417.01
ISO9496/01

iGuzzini

استبدال الضوء LED
SOSTITUZIONE DEL LED
REPLACING THE LED
REEMPLAZO DEL LED

ملاحظة: لاستبدال الضوء، اتصل بشركة iGuzzini

I N.B.: Per la sostituzione del LED contattare l'azienda iGuzzini.

GB N.B.: For information on LED replacement please contact iGuzzini.

E NOTA: Para sustituir el LED llame a la empresa iGuzzini.

تفاسم نم، ءل يوط قرتفل زاهجلا تبقارم عقوت مدع رابتعالا
ني عب ذخوي ثي حب، زاهجلا عضو بجي رتم 1 نم لقا

I L'apparecchio dovrebbe essere posizionato in modo che non sia prevista un'osservazione prolungata dell'apparecchio ad una distanza inferiore di 1 m.

GB The luminaire should be positioned so that prolonged staring into the luminaire at a distance closer than 1 m is not expected.

E El aparato debe emplazarse de manera tal que la observación prolongada se realice a una distancia de al menos 1 m.

- I Istruzioni per le operazioni di servizio per l'apparecchio di illuminazione**
GB Instructions on luminaire service operations
F Instructions pour les opérations de service du luminaire
D Wartungsanleitung für die Leuchte
NL Instructies voor de onderhoudsoperaties op de verlichtingsarmatuur
E Instrucciones para las operaciones de servicio del aparato de alumbrado
DK Anvisninger i serviceindgreb på belysningsarmatur
N Anvisninger for betjening av lysapparatet
S Instruktioner för användning av belysningsanordningen
RUS Инструкция по эксплуатации осветительного прибора
CN 照明装置检修操作说明

Sostituire la lampada parzialmente esausta
 Replace the partly exhausted lamp
 Remplacer la lampe partiellement épuisée
 Die teilweise erschöpfte Lampe austauschen
 Vervang de gedeeltelijk lege lamp
 Sustituir la lámpara parzialmente agotada
 Udskift den delvist udtjente pære
 Skifte ut den delvis utbrente lyspæren
 Byt ut den delvis förbrukade lampan
 Замена частично отработанной лампочки
 更换部分老化的灯泡

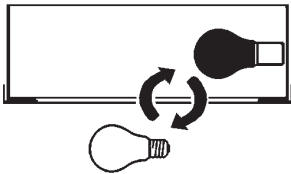

Spegnimento
 Switch it off
 Extinction
 Ausschaltung
 Uitschakeling
 Apagado
 Slukning
 Slukking
 Släckning
 Выключение
 关灯

Interrompere l'alimentazione dell'apparecchio
 Cut the power supply to the luminaire
 Couper l'alimentation du luminaire
 Stromversorgung der Leuchte unterbrechen
 Onderbreek de voeding van het apparaat
 Interrumpir la alimentación del aparato
 Afbryd armaturets strømforsyning
 Avbryte strømtilførselen til apparatet
 Koppla från anordningens strömförsörjning
 Отключить электропитание прибора
 中断装置供电

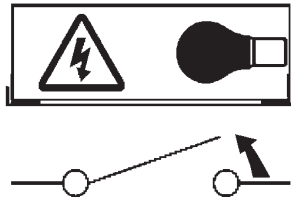

Aprire l'apparecchio
 Open the fixture
 Ouvrir le luminaire
 Das Gerät öffnen
 Open het apparaat
 Abrir el aparato
 Åbn armaturet
 Åpne apparatet
 Öppna anordningen
 Раскрыть прибор
 打开装置

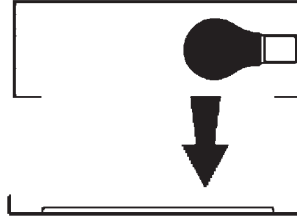

Rimuovere la lampada esausta
 Remove the exhausted lamp
 Retirer la lampe épuisée
 Die alte Lampe entnehmen
 Verwijder de lege lamp
 Quitar la lámpara agotada
 Tag den udtjente pære ud
 Fjerne den utbrente lyspæren
 Ta bort den förbrukade lampan
 Вынуть старую лампочку
 取出老化的灯泡

Portarla in un centro di riciclaggio
 Carry it to a recycling centre
 La porter dans une déchetterie pour son recyclage
 Ordnungsgemäß entsorgen
 Breng de lamp naar een recyclingcentrum
 Llevarla a un centro de reciclaje
 Aflever den på en genbrugsstation
 Lever den til en miljøstasjon
 Lämna in den till en återvinningsanläggning
 Сдать ее в пункт приема утильсырья
 将其送往回收中心

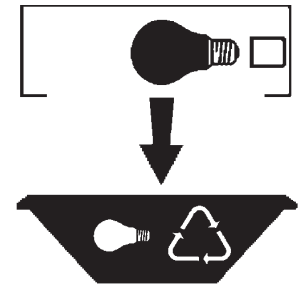

Inserire la nuova lampada
 Introduce the new lamp
 Installer la lampe neuve
 Die neue Lampe einsetzen
 Doe de nieuwe lamp op zijn plek
 Montar la nueva lámpara
 Sæt den nye pære i
 Sette i den nye pæren
 Sätt i den nya lampan
 Вставить новую лампочку
 装入新灯泡

Inserire la nuova lampada nel portalampada
 Fit the new lamp into the socket
 Installer la nouvelle lampe dans le support de lampe
 Die neue Lampe in den Sockel einsetzen
 Doe de nieuwe lamp in de lamphouder
 Montar la nueva lámpara en el portalámpara
 Sæt den nye pære i fatningen
 Sette den nye pæren inn i lampeholderen
 Sätt i den nya lampan i lamphållaren
 Вставить новую лампочку в патрон
 将新灯泡插入灯泡架中



Riposizionare ottica
 Re-place the optic
 Remettre l'optique à sa place
 Die Optik wieder einsetzen
 Doe de optiek weer op zijn plaats
 Volver a montar la óptica
 Sæt den optiske enhed på plads
 Innstille linsen
 Flytta om optiken
 Отрегулировать линзы
 重新定位光头

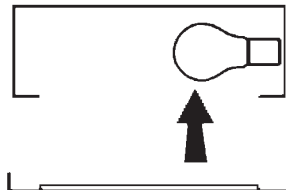

Effettuare prova di funzionamento
 Perform operative test
 Procéder à un essai de fonctionnement
 Eine Funktionsprüfung durchführen
 Controleer de correcte werking
 Hacer una prueba de funcionamiento
 Afprøv funktionen
 Prøve om den fungerer
 Utför funktionstest
 Выполнить проверку исправности работы
 执行功能测试

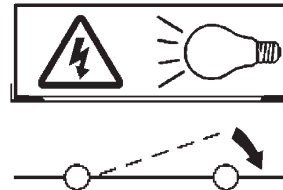

I Istruzioni per la pulizia dell'apparecchio di illuminazione
GB Instructions on luminaire cleaning operations
F Instructions pour le nettoyage du luminaire
D Anweisungen zur Reinigung der Leuchte
NL Instructies voor de reiniging van de verlichtingsarmatuur
E Instrucciones para limpiar el aparato de alumbrado
DK Anvisninger i rengøring af belysningsarmaturet
N Anvisninger for rengjøring av lysapparatet
S Instruktioner för rengöring av belysningsanordningen
RUS Инструкции по чистке осветительного прибора
CN 照明装置清洁说明

Pulire l'apparecchio
Clean the fixture
Nettoyer le luminaire
Das Gerät reinigen
Reinig het apparaat
Limpiar el aparato
Rengør armaturet
Rengjøre apparatet
Rengör anordningen
Чистка прибора
清洁装置

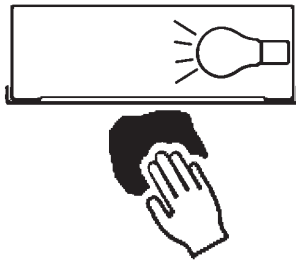

Spegnimento
Switch it off
Extinction
Ausschaltung
Uitschakeling
Apagado
Slukning
Slukking
Släckning
Выключение
关灯

Interrompere l'alimentazione dell'apparecchio
Cut the power supply to the luminaire
Couper l'alimentation du luminaire
Stromversorgung der Leuchte unterbrechen
Onderbreek de voeding van het apparaat
Interrumpir la alimentación del aparato
Afbryd armaturets strømforstyrning
Avbryt strømtilførselen til apparatet
Koppla från anordningens strömförsörjning
Отключить электропитание прибора
中断装置供电



Spolverare l'ottica esterna
Remove dust from the external optic
Dépoussiérer l'optique extérieure
Die externe Optik abstauben
Stof de externe optiek af
Quitar el polvo de la óptica exterior
Tør støvet af den udvendige optiske enhed
Fjerne støv fra den eksterne lysenheten
Damma av den yttre optiken
Вытереть пыль с внешней стороны линз
为外侧镜头掸尘

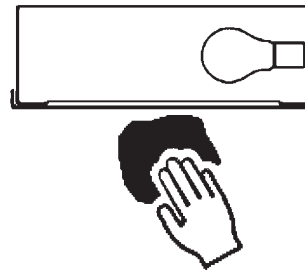

Lavare l'ottica esterna
Wash the external optic
Laver l'optique extérieure
Die externe Optik waschen
Was de externe optiek
Lavar la óptica exterior
Vask den udvendige optiske enhed
Vaske den eksterne lysenheten
Rengör den yttre optiken
Вымыть линзы с внешней стороны
清洁外镜头



Rimuovere l'ottica
Remove the optic
Retirer l'optique
Die Optik abnehmen
Verwijder de optiek
Quitar la óptica
Tag den optiske enhed af
Fjerne lysenheten
Ta bort optiken
Снять линзы
取下镜头



Pulire la parte interna dell'apparecchio di illuminazione
Clean the inside of the fixture
Nettoyer l'intérieur du luminaire
Die Innenseite der Leuchte reinigen
Reinig de binnenzijde van de verlichtingsarmatuur
Limpiar el interior del aparato de alumbrado
Rengør belysningsarmaturets indvendige dele
Rengjøre lysapparatet innvendig
Rengör belysningsanordningen invändigt
Протереть осветительный прибор изнутри
清洁照明装置内部



Riposizionare ottica
Re-place the optic
Remettre l'optique à sa place
Die Optik wieder einsetzen
Doe de optiek weer op zijn plaats
Volver a montar la óptica
Sæt den optiske enhed på plads
Innstille linsen
Flytta om optiken
Отрегулировать линзы
重新定位镜头

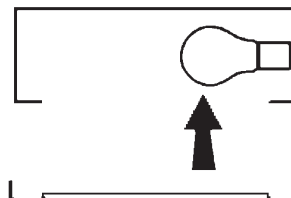

Effettuare prova di funzionamento
Perform operative test
Procéder à un essai de fonctionnement
Eine Funktionsprüfung durchführen
Controleer de correcte werking
Hacer una prueba de funcionamiento
Afprøv funktionen
Prøve om den fungerer
Utför funktionstest
Выполнить проверку исправности работы
执行功能测试

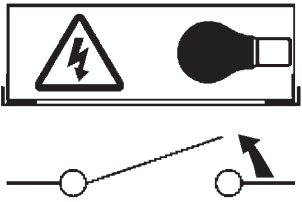
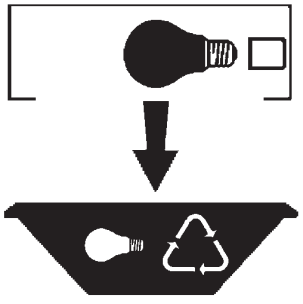
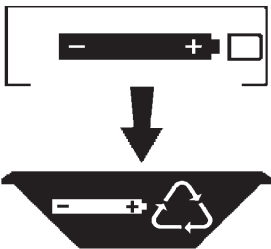
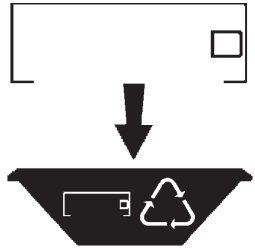

- I Istruzioni per il fine vita e lo smaltimento dei componenti
- GB Instructions on end-of-life and component disposal
- F Instructions pour la gestion des composants en fin de vie et leur mise au rebut
- D Anweisungen zur Entsorgung der Leuchtenkomponenten
- NL Instructies voor het verwijderen van de armatuur en het recyclen van de onderdelen
- E Instrucciones para el final de vida y la eliminación los componentes
- DK Anvisninger i udtjent armatur og bortskaffelse af komponenter
- N Anvisninger for endt levetid og avfallsbehandling av delene
- S Instruktioner vid bortskaffning och kassering av komponenter
- RUS Инструкции по утилизации прибора и его комплектующих по окончании его срока службы
- CN 寿命期结束与零件废弃处置说明

<p>Spegnimento Switch it off Extinction Ausschaltung Uitschakeling Apagado Slukning Slukking Släckning Выключение 关灯</p> <p>Interrompere l'alimentazione dell'apparecchio Cut the power supply to the luminaire Couper l'alimentation du luminaire Stromversorgung der Leuchte unterbrechen Onderbreek de voeding van het apparaat Interrompirla alimentación del aparato Afbryd armaturets strømforsyning Avbryt strømtilførselen til apparatet Koppla från anordningens strömförsörjning Отключить электропитание прибора 中断装置供电</p> 	<p>Rimuovere la/e lampada/e per la dismissione Remove the lamp(s) for decommissioning Retirer la(les) lampe(s) pour sa(leur) mise au rebut Die Lampe/n ordnungsgemäß entsorgen Verwijder de lamp(en) voor het recyclen Quitar la(s) lámpara(s) para el desecho Tag pæren/pærerne ud til bortskaffelse Fjerne lampen/-e som skal kastes Ta bort lampan/-orna för bortskaffningen Вынуть лампочку/и для утилизации прибора 取出需要丢弃的灯泡</p> 	<p>Rimuovere la batteria per la dismissione Remove the battery for decommissioning Retirer la batterie pour sa mise au rebut Die Batterie ordnungsgemäß entsorgen Verwijder de batterij voor het recyclen Quitar la batería para el desecho Tag batteriet ud til bortskaffelse Fjerne batteriet som skal kastes Ta bort batteriet för bortskaffningen Вынуть батарейку для утилизации прибора 取出需要丢弃的电池</p> 	<p>Rimuovere l'apparecchio per la dismissione Remove the fixture for decommissioning Enlever le luminaire pour sa mise au rebut Das Gerät ordnungsgemäß entsorgen Verwijder het apparaat voor het recyclen Quitar el aparato para el desecho Tag armaturet ud til bortskaffelse Fjerne apparatet som skal kastes Ta bort anordningen för bortskaffningen Снять прибор для утилизации 取出需要丢弃的装置</p> 
---	--	--	--

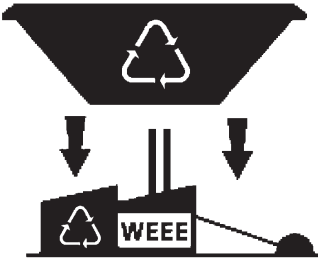
<p>Inviare i materiali ad un centro di raccolta RAEE Send the materials to a WEEE collection centre Envoyer les matériaux dans une déchetterie DEEE Die Materialien in einem WEEE-Zentrum entsorgen Zend de materialen naar een recyclingscentrum voor de AEEA Enviar los materiales a un centro de recogida RAEE Afløver materialerne på et indsamlingscenter for elektronisk udstyr Sende materialene til en miljøstasjon for resirkulering av EE-avfall Skicka materialet till en RAEE uppsamlingscentral Сдать материалы в пункт приема утильсырья 将材料送往电气和电子垃圾回收中心</p> 			
--	--	--	--