

LINEALUCE MINI 37R MONOCHROME (PWM)

I ATTENZIONE:

LA SICUREZZA DELL'APPARECCHIO E' GARANTITA SOLO CON L'USO APPROPRIATO DELLE SEGUENTI ISTRUZIONI; PERTANTO E' NECESSARIO CONSERVARLE.

GB WARNING:

THE SAFETY OF THIS FIXTURE IS GUARANTEED ONLY IF YOU COMPLY WITH THESE INSTRUCTIONS; REMEMBER TO CONSERVE IN A SAFE PLACE.

F ATTENTION:

LA SECURITE DEL L'APPAREIL N'EST GARANTIE QU'EN CAS D'UTILISATION CORRECTE DES INSTRUCTIONS SUIVANTES; IL FAUT PAR CONSEQUENT LES CONSERVER.

D ACHTUNG:

DIE SICHERHEIT DES GERÄTES WIRD NUR DURCH SACHGEMÄSSE BEFOLGUNG NACHSTEHENDER ANWEISUNGEN GEWÄHRLEISTET; IHRE AUFBEWAHRUNG IST DESHALB SEHR WICHTIG.

NL OPGELET:

DE VEILIGHEID VAN DI ATOESTEL IS SLECHTS DAN GEGARANDEERD ALS INDIEN DE VOLGENDE INSTRUCTIES STRIKT WORDEN TOEGEPAST: DAAROM MOET MEN ZE OOK BEWAREN.

E ATENCION:

LA SEGURIDAD DEL APARATO SE GARANTIZA SOLO CUMPLIENDO CUIDADOSAMENTE LAS SIGUIENTES INSTRUCCIONES; POR ELLO, ES NECESARIO CONSERVARLAS.

DK BEMÆRK:

SIKKERHEDEN VED BRUG AF ARMATURET KAN KUN GARANTERES, HVIS DISSE ANVISNINGER FØLGES; SØRG DERFOR FOR AT GEMME DEM.

N ADVARSEL:

SIKKERHETEN TIL DETTE APPARATET GARANTERES KUN HVIS DU OVERHOLDER DISSE INSTRUKSJONENE; HUSK Å OPPBEVARE DEM PÅ ET TRYGT STED.

S OBSERVERA!

UTRUSTNINGENS SÄKERHET KAN ENDAST GARANTERAS OM DESSA ANVISNINGAR RESPEKTERAS I DETALJ. SPARA DÄRFÖR DESSA ANVISNINGAR FÖR FRAMTIDA KONSULTATION.

RUS ВНИМАНИЕ:

МЫ ГАРАНТИРУЕМ БЕЗОПАСНУЮ ЭКСПЛУАТАЦИЮ ИЗДЕЛИЯ ТОЛЬКО ПРИ СОБЛЮДЕНИИ СЛЕДУЮЩИХ ИНСТРУКЦИЙ; С ЭТОЙ ЦЕЛЬЮ НЕОБХОДИМО СОХРАНИТЬ ДАННУЮ БРОШЮРУ.

CN 警告

为确保该装置安全，请遵守操作指示；并于安全场所放置。

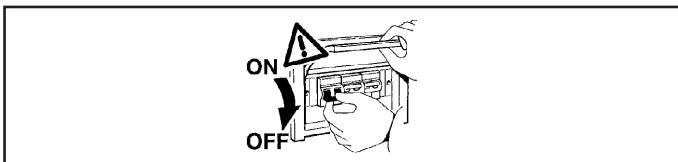
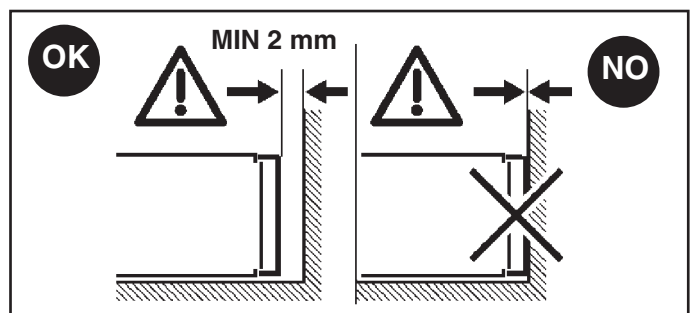
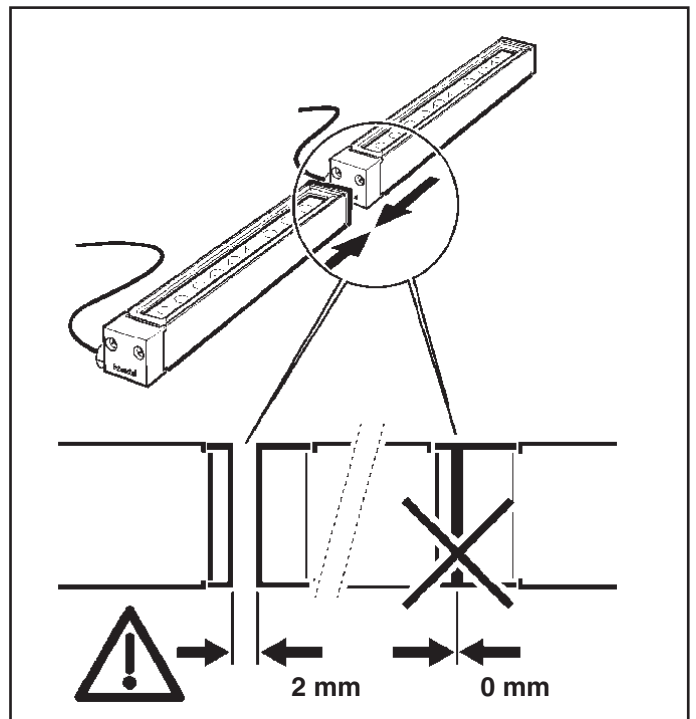
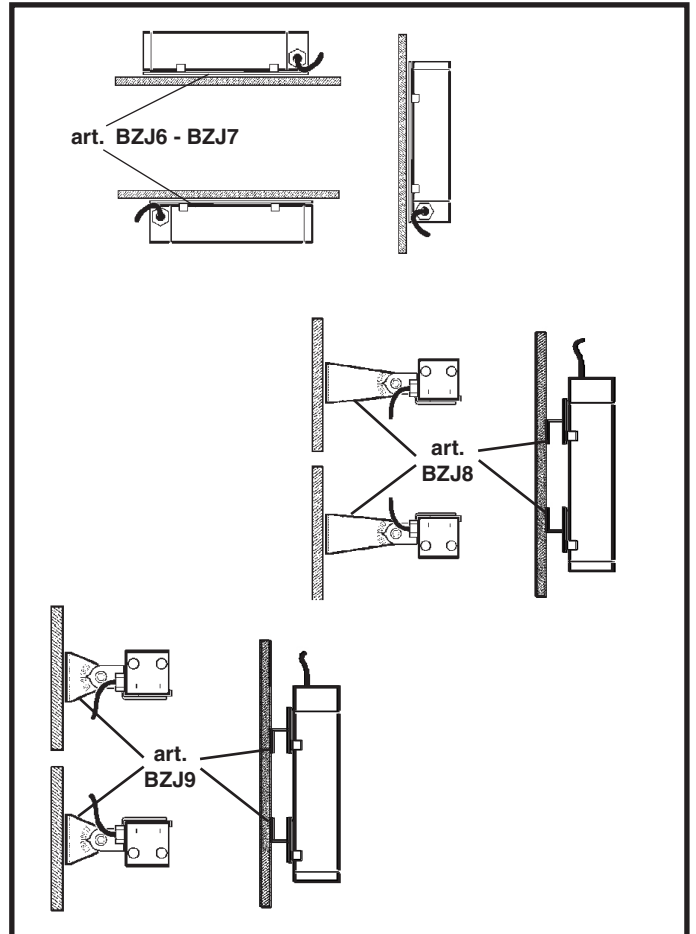
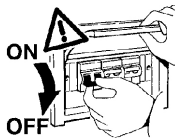

	ART.	L (mm)
	BH14 - BH15 - BH20 - BH21 BK36 - BK37 - BK80 - BK81	528
	BI11 - BI12	792
	BH16 - BH17 - BH22 - BH23 BK40 - BK41 - BK84 - BK85	1056
	BI13 - BI14	1321
	BH18 - BH19 - BH24 - BH25	1585

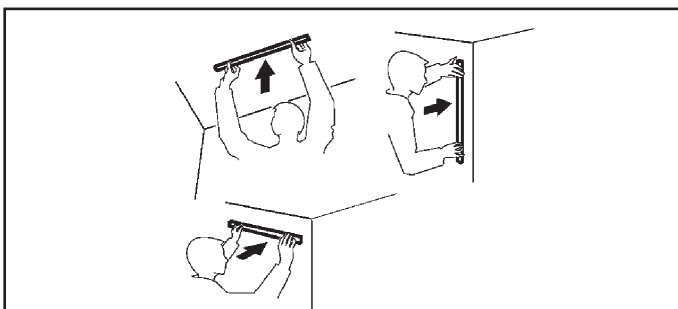

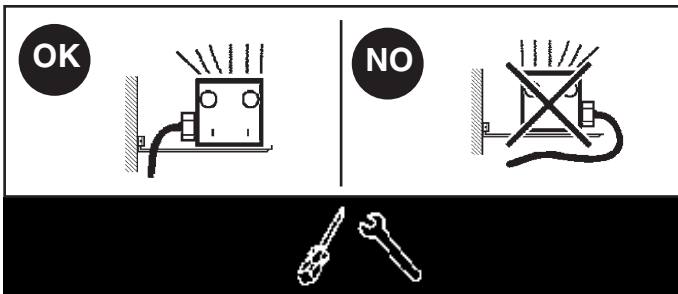

INSTALLAZIONE DEI SUPPORTI MECCANICI
INSTALLATION OF THE MECHANICAL SUPPORTS
INSTALLATION DES SUPPORTS MECANIQUES
BEFESTIGUNG DER HALTEVORRICHTUNGEN
HET INSTALLEREN VAN DE MECHANISCHE STEUNEN
INSTALACIÓN DE LOS SOPORTES MECÁNICOS
INSTALLATION AF MEKANISKE HOLDERE
INSTALLASJON AV DE MEKANISKE STØTTENE
INSTALLATION AV METALLHÅLLARE
МОНТАЖ МЕХАНИЧЕСКИХ КРЕПЛЕНИЙ
机械支架的安装

TABELLA INTERASSI DI FORATURA
 TABLE OF CENTRE TO CENTRE DISTANCES OF HOLING
 TABLEAU DES ESPACEMENT DE PERÇAGE
 TABELLE DER BOHR - MITTENABSTÄNDE
 TABEL VAN DE AFSTAND TUSSEN DE ASSEN VAN DE GATEN
 TABLA INTER - EJES DE PERFORACION
 TABEL OVER HULAFSTAND
 TABELL OVER AVSTANDER PÅ HULLING SENTER TIL SENTER
 TABELL FÖR HÅLDELNING
 ТАБЛИЦА ШАГОВ ОТВЕРСТИЙ
 面板孔的中心距离

ART.	BZJ8 BZJ9	BZJ6	BZJ7
	K (mm)	K (mm)	K (mm)
BH14 - BH15 - BH20 - BH21 - BK36 BK37 - BK80 - BK81	220		
BI11 - BI12		265	/
BH16 - BH17 - BH22 - BH23 - BK40 BK41 - BK84 - BK85	400		
BI13 - BI14			600
BH18 - BH19 - BH24 - BH25		/	

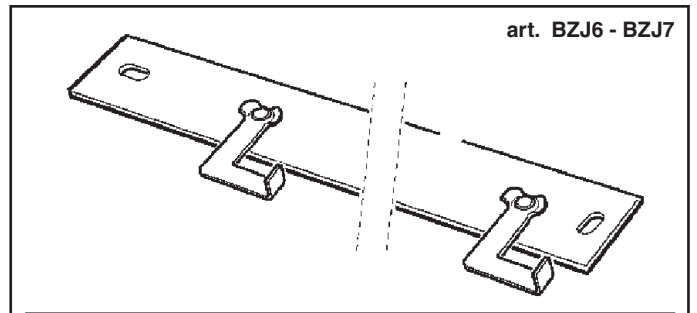
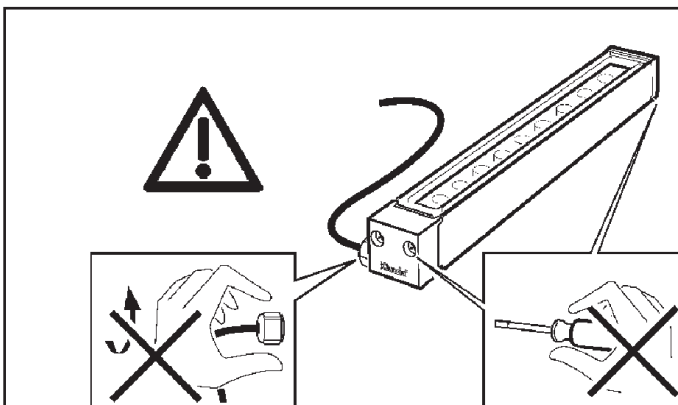
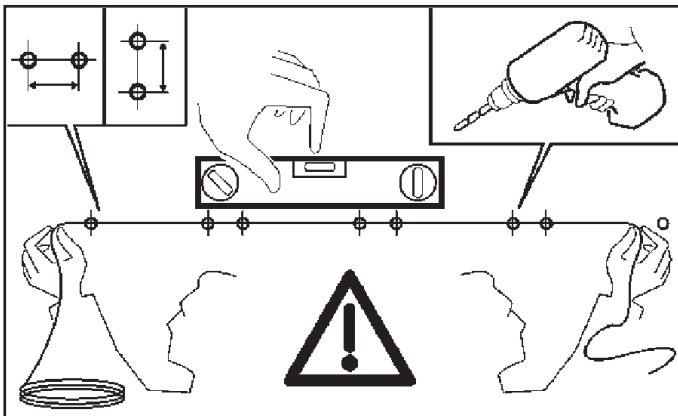

art. BZJ6 - BZJ7

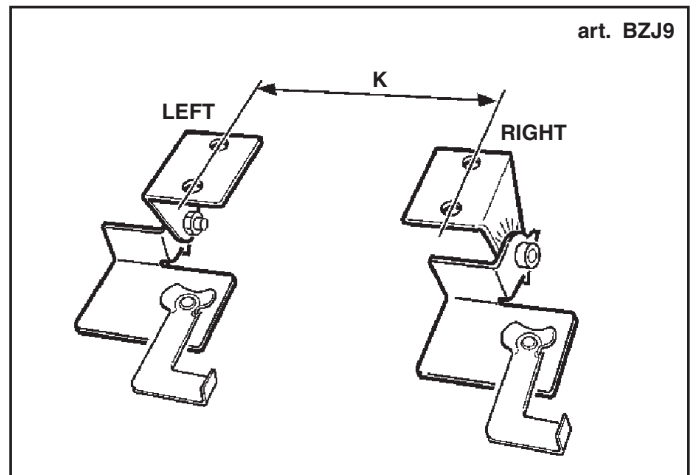
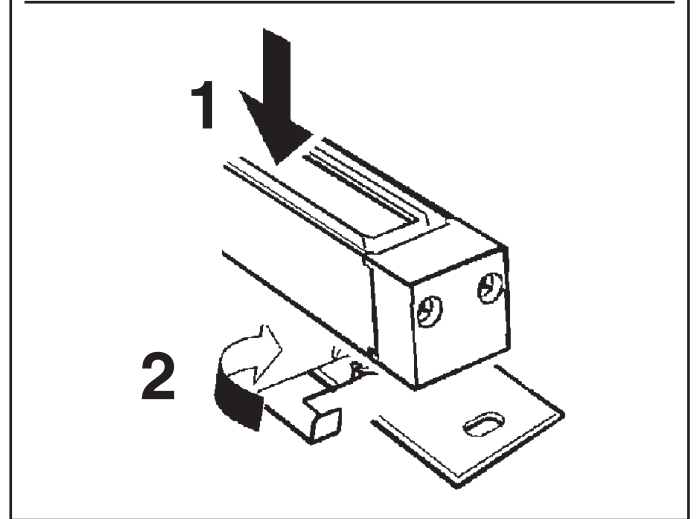
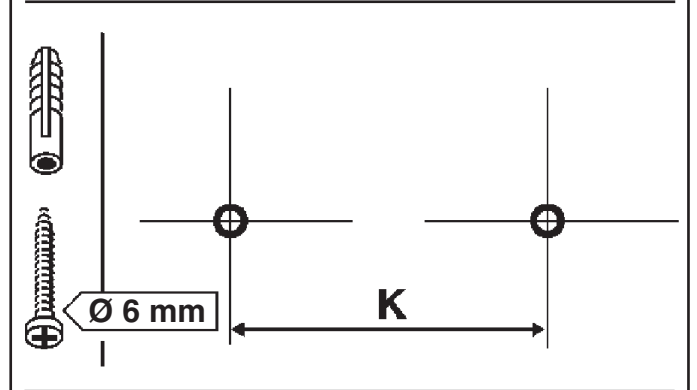

art. BZJ9

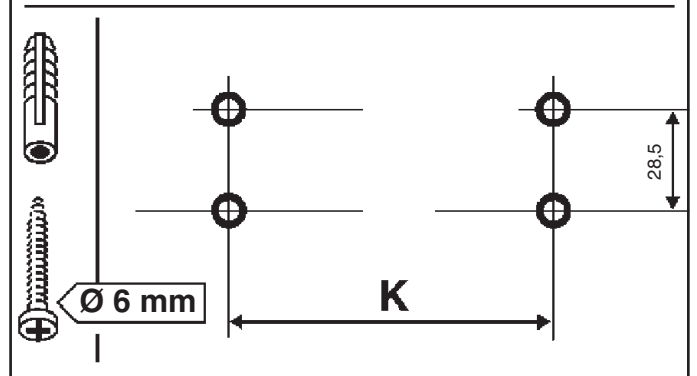

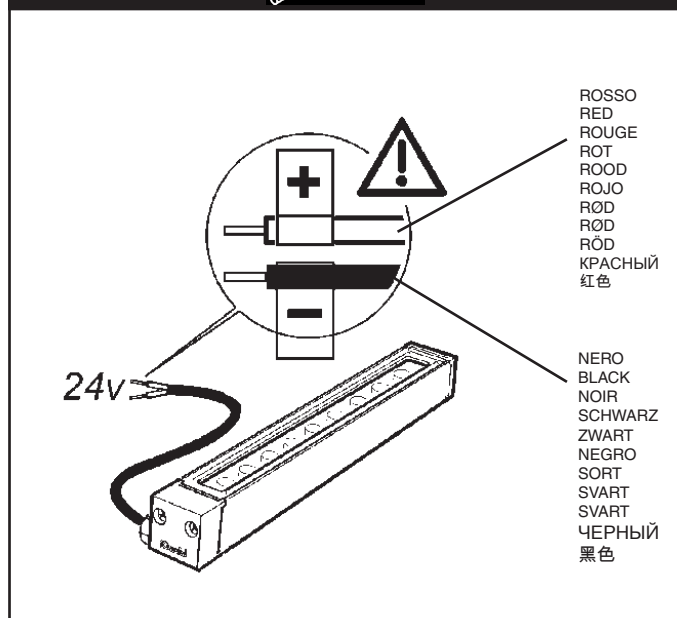
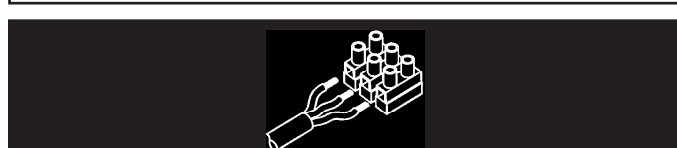
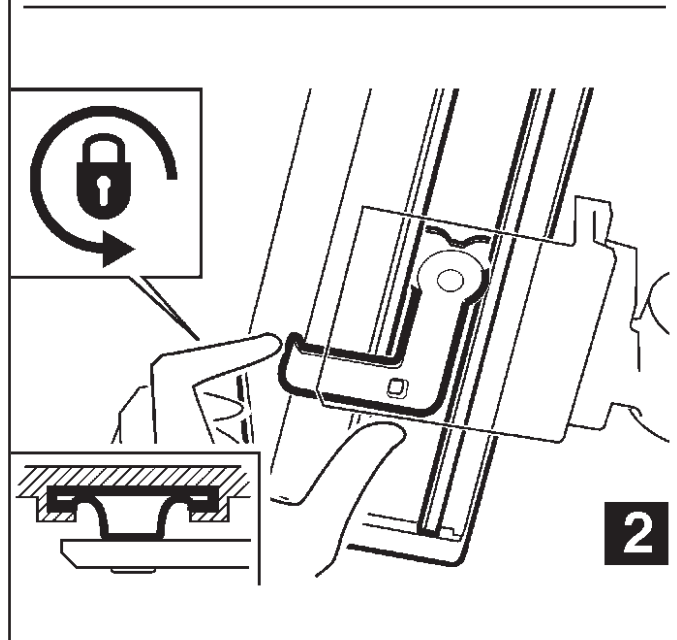
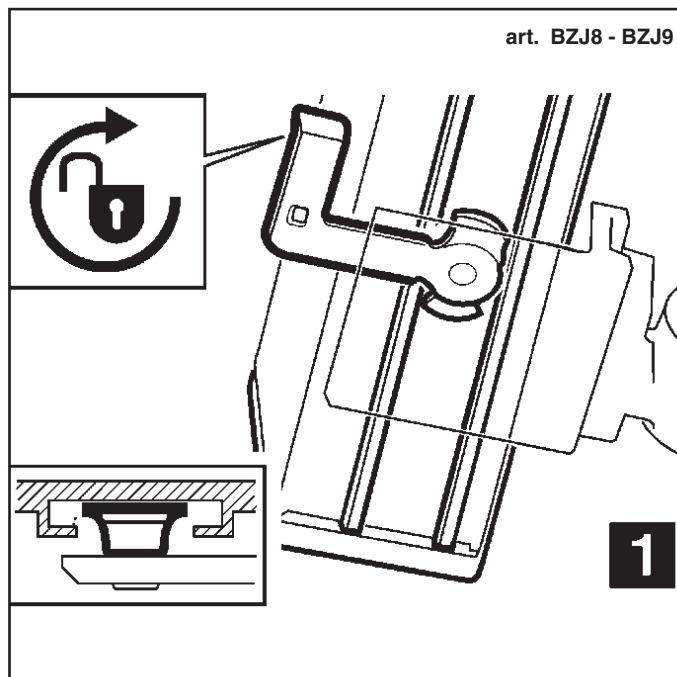
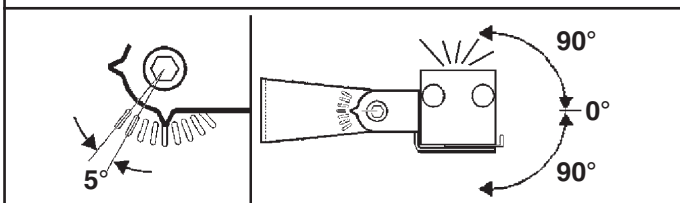
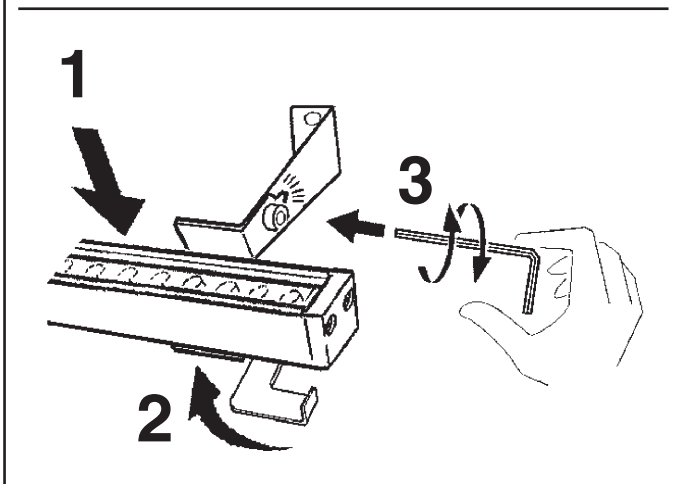
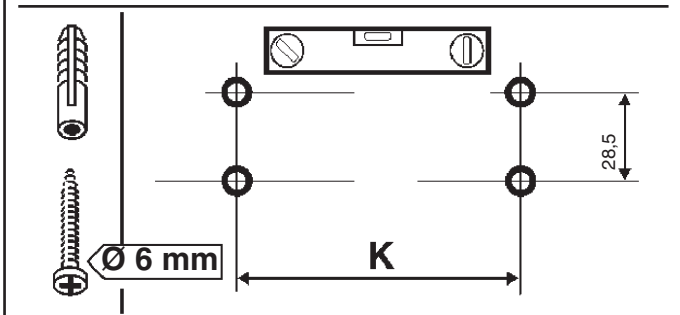
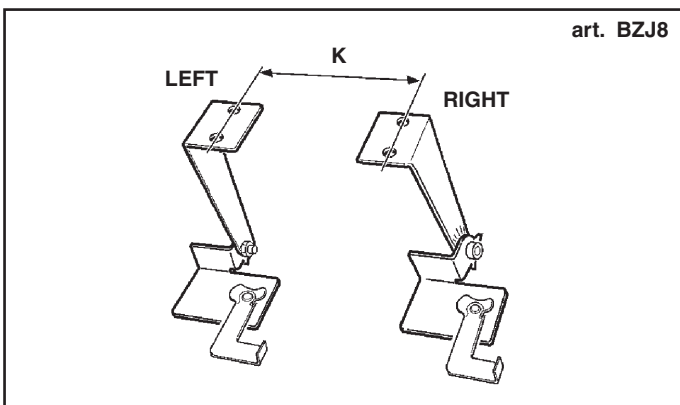
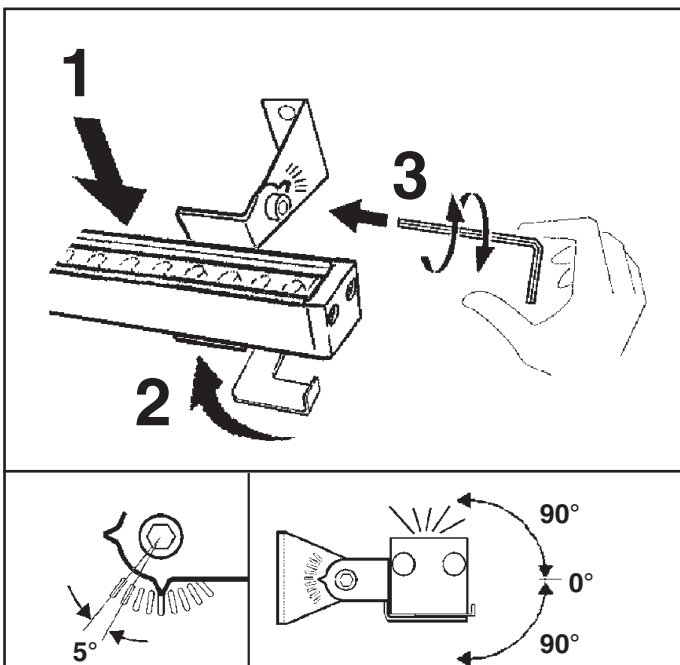

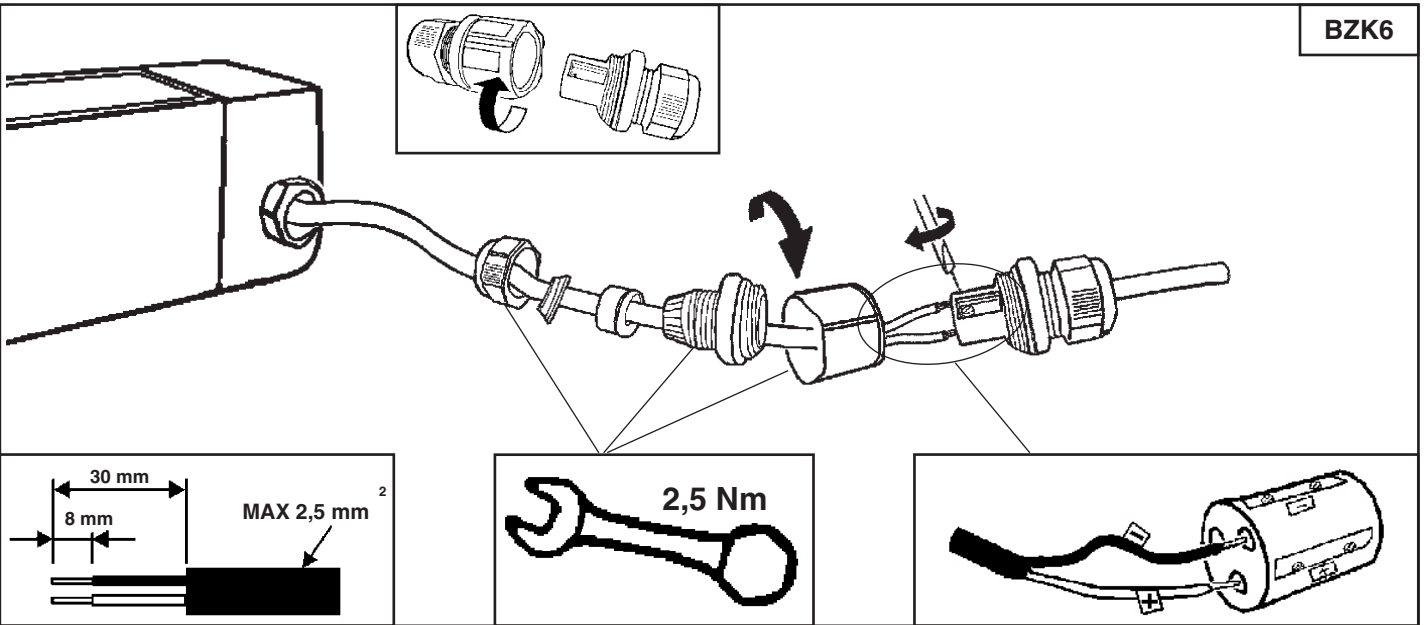

6,5 ÷ 8 mm	
8 ÷ 9 mm	
9 ÷ 13 mm	

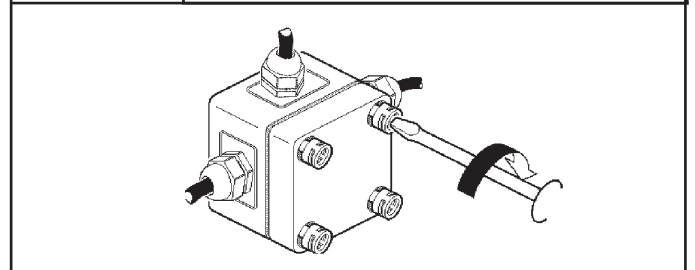
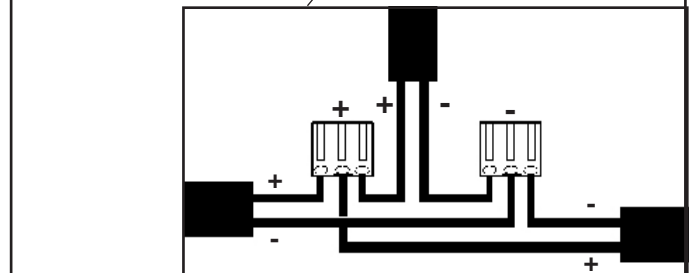
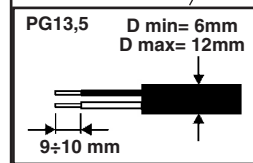
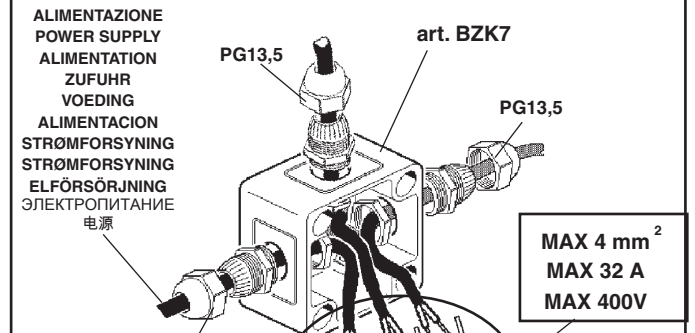
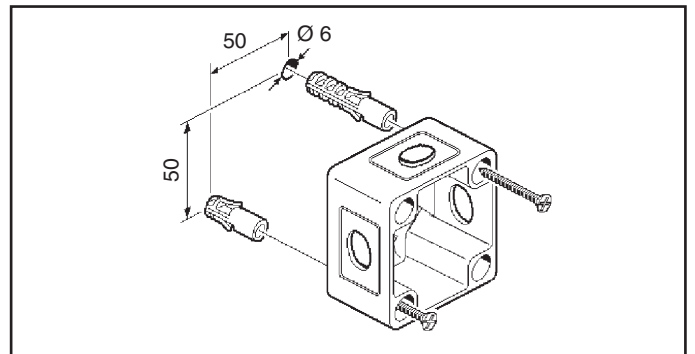

BZK7

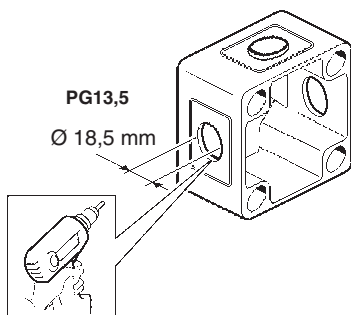
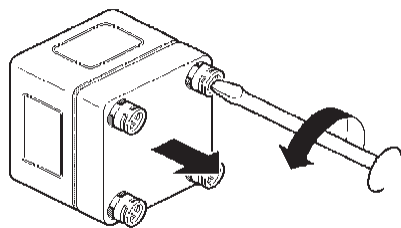

ESEMPIO - EXAMPLE
 EXEMPLE - BEISPIEL - VOORBEELD
 EJEMPLO - EKSEMPEL - EXEMPEL
 ПРИМЕР - 例子

BZK7

BZK6

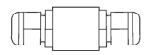
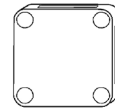

art. BZK0 - BZK1 - 9908 - 9909 - 9910 - 9911 - 9912
 X182 - X183 - X184 - X185 - X186 - X187

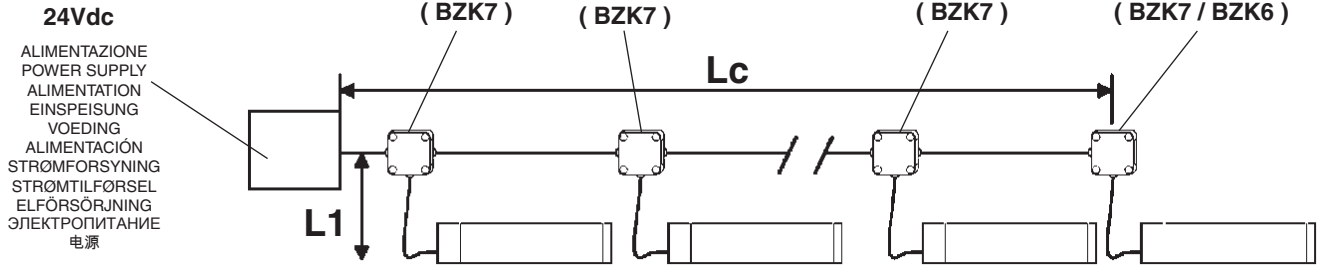

NO DIMMING VERSION

- I Per calcolare la lunghezza del cavo Max:
 GB To calculate the max length of the cable:
 F Pour calculer la longueur maximale du câble :
 D Zur Berechnung der max. Kabellänge:
 NL Om de Max lengte van de kabel te calculeren:
 E Para calcular la longitud del cable Máx:
 DK For at beregne den maksimale kabellængde
 N For å beregne maksimal lengde på kabel:
 S För att beräkna max. kabellängd:
 RUS Для расчета макс. длины кабеля:
 CN 计算电缆线的最大长度 :

$$LC[m] = \frac{\Delta x[V] * Sc[mm^2]}{2 * Np * I [A] * 0,0174}$$

- △ x = Caduta di tensione ammissibile tra alimentatore e la tensione minima di funzionamento del prodotto
 △ x = Allowed voltage drop between the power-supply unit and minimum operating voltage of the product
 △ x = Chute de tension admissible entre le ballast et la tension minimale de fonctionnement du produit
 △ x = Zulässiger Spannungsabfall zwischen Vorschaltgerät und Mindestbetriebsstrom des Produkts
 △ x = Een val van de spanning is toegestaan tussen het voorschakelapparaat en de minimum werkingsspanning van het product.
 △ x = Caída de tensión permitida entre el alimentador y la tensión mínima de funcionamiento del producto
 △ x = Tillådt spændingsfald mellem strømforsyning og produktets minimumsdriftsspænding
 △ x = Godkjent spenningsfall mellom transformatoren og produktets laveste driftsspennning
 △ x = Tillåtet spenningsfall mellan nätaggregat och minimispänningen för produktens funktion
 △ x = Допустимое падение напряжения между блоком питания и минимальным рабочим напряжением изделия
 △ x = 允许压降在产品的电源组件与最小工作电压之间

ESEMPIO - EXAMPLE - EXEMPLE - BEISPIEL - VOORBEELD
 EJEMPLO- EKSEMPEL -EXEMPEL - ПРИМЕР - 例子

Power-supply voltage = 28V
 Minimum product voltage = 16V
 ⇒ △ x = 28-16=12V

- I PER GARANTIRE IL CORRETTO FUNZIONAMENTO LA TENSIONE MINIMA SUL PRODOTTO AL 100%, CIOE' SENZA DIMMERAZIONE, DEVE ESSERE 16V.
 GB TO ENSURE CORRECT OPERATION, THE MINIMUM VOLTAGE ON THE PRODUCT AT 100% - THAT IS, WITHOUT DIMMING - MUST BE 16 V.
 F POUR ASSURER UN BON FONCTIONNEMENT, LA TENSION MINIMALE SUR LE PRODUIT À 100%, C'EST À DIRE SANS GRADATION, DOIT ÊTRE DE 16V.
 D FÜR EINEN STÖRUNGSFREIEN BETRIEB IST EINE SPANNUNG VON MINDESTENS 16 V ERFORDERLICH, DIE ZU 100 % - ALSO OHNE DIMMEN - AM GERÄT ANLIEGT.
 NL PARA GARANTIZAR EL FUNCIONAMIENTO CORRECTO LA TENSÓN MÍNIMA SOBRE EL PRODUCTO AL 100%, ES DECIR, SIN DIMMER, DEBE SER 16V.
 E TIL SIKRING AF KORREKT FUNKTION SKAL MINIMUM SPÆNDING PÅ PRODUKTION VED 100%, UDEN DÆMPNING, VÆRE 16V.
 DK OM DE JUISTE WERKING TE GARANDEREN MOET DE MINIMALE SPANNING OP HET PRODUCT BIJ 100%, D.W.Z. ZONDER DIMMER, 16V ZIJN.
 N FOR AT MAN SKAL VÆRE GARANTERT KORREKT FUNKSJON, MÅ MINSTESPENNINGEN I PRODUKTET VED 100 %, DVS. UTEN DIMMEREFFEKT, VÆRE 16V.
 S FÖR ATT GARANTERA KORREKT FUNKTION MÅSTE LÄGSTA SPÄNNING PÅ PRODUKTEN VID 100 % (UTAN DIMNING) VARA 16 V.
 RUS ЧТОБЫ БЫЛА ГАРАНТИРОВАНА ИСПРАВНАЯ РАБОТА, МИНИМАЛЬНОЕ НАПРЯЖЕНИЕ НА ИЗДЕЛИЕ ПРИ 100%, ТО ЕСТЬ БЕЗ РЕГУЛИРОВАНИЯ СИЛЫ СВЕТА, ДОЛЖНО СОСТАВЛЯТЬ 16 В.
 CN 为确保正确操作，亮度为 100% 时——即，非昏暗情形——产品最小电压必须为 16 V。

- I Definire il numero di prodotti Max. (Np) in funzione della sezione del cavo utilizzata (Sc).
 GB Define the max number of products (Np) based on the cable section used (Sc).
 F Définir le nombre maximum de produits (Np) en fonction de la section de câble utilisée (Sc).
 D Die maximale Produktzahl (Np) im Verhältnis zum verwendeten Kabeldurchmesser (Sc) definieren.
 NL Bepaal het Max. aantal producten (Np) aan de hand van de diameter van de gebruikte kabel (Sc).
 E Definir el número de productos Máx. (Np) en función de la sección del cable utilizada (Sc).
 DK Definér det maksimale antal produkter (Np) i forhold til det anvendte kabels tværsnit (Sc)
 N Definere maksimalt antall produkter (Np) på grunnlag av tverrsnittet til ledningen som benyttes (Sc).
 S Ange max. antal produkter (Np) beroende på kabeltvärsnittet som används (Sc).
 RUS Максимальное количество приборов Max. (Np) определяется в зависимости от сечения используемого кабеля (Sc).
 CN 根据所用电缆的截面 (Sc) 确定产品数量的上限 (Np) 。

<p>n° prodotti no. of products nbre de produits Anz. Produkte Aantal producten Cantidad de productos Anal produkter Antall produkter Antal produkter кол-во изделий 产品数量</p> 	<p>SEZIONE DEL CAVO ESTERNO EXTERNAL WIRE CROSS-SECTION SECTION DU CÂBLE EXTÉRIEUR QUERSCHNITT DES AUBENKABELS DOORSNEDE VAN DE EXTERNE KABEL SECCIÓN DEL CABLE EXTERNO SNIT PÅ EKSTERN LEDNING TVERRSNITT AV YTRE LEDNING TVÄRSNITT FÖR EXTERN KABEL сечение внешнего провода 外部电缆部分 (mm²)</p>	<p>LUNGHEZZA MASSIMA DEL CAVO DALL'ALIMENTATORE ALLA SCATOLA DI DERIVAZIONE MAXIMUM LENGTH OF POWER SUPPLY CABLE TO JUNCTION BOX LONGUEUR MAXIMALE DU CÂBLE DU BALLAST À LA BOÎTE DE DÉRIVATION MAXIMALE LÄNGE DES KABELS VOM VORSCHALTGERÄT ZUR ABZWEIGDOSE MAXIMALE LENGTE VAN DE KABEL VANAF HET VOORSCHAKELAPPARAAT NAAR DE AFTAKDOOS LONGITUD MÁXIMA DEL CABLE DE ALIMENTADOR A LA CAJA DE DERIVACIÓN MAKS. LÆNGDE PÅ STRØMFORSYNINGSLIGNING TIL SAMLEDÅSE MAKSIMAL LENGDE TIL KABELN TIL TRANSFORMATOREN TIL KOBLINGSBOKSEN MAX. LÅNGD FÖR KABELN FRÅN STRÖMFÖRSÖRJNINGSANORDNINGEN TILL KOPPLINGSDOSAN Максимальная длина кабеля от распределительной коробки 从接线盒的电缆最大长度 Lc (m)</p>	<p>LUNGHEZZA MASSIMA DEL CAVO (1 mm²) DALLA SCATOLA DI DERIVAZIONE AI PRODOTTI MAXIMUM LENGTH OF THE CABLE (1 mm²) FROM THE CONNECTOR BLOCK TO THE PRODUCTS LONGUEUR MAXIMALE DU CÂBLE (1 mm²) DE LA BOÎTE DE DÉRIVATION AUX PRODUITS MAXIMALE LÄNGE DES KABELS (1 mm²) VON DER ABZWEIGDOSE ZU DEN PRODUKTEN MAXIMALE LENGTE VAN DE KABEL (1 mm²) VANAF DE AANSLUITBOX TOT DE PRODUCTEN. LONGITUD MÁXIMA DEL CABLE (1 mm²) DE LA CAJA DE DERIVACIÓN A LOS PRODUCTOS MAKS. LÆNGDE PÅ FORSYNINGSLIGNINGEN (1 mm²) FRA SAMLEDÅSE TIL PRODUKTERNE MAKSIMAL LENGDE PÅ KABELN (1 mm²) FRA KOBLINGSBOKSEN TIL PRODUKTENE MAX. KABELLÅNGD (1 mm²) FRÅN KOPPLINGSDOSAN TILL PRODUKTERNA МАКСИМАЛЬНАЯ ДЛИНА ПРОВОДА (1 мм²) ОТ ОТВЕТВИТЕЛЬНОЙ КОРОБКИ ДО ПРИБОРОВ 从连接器插头块到产品的线缆最大长度 (1 MM²) L1</p>	<p>TENSIONE DI ALIMENTAZIONE POWER SUPPLY VOLTAGE TENSION D'ALIMENTATION VERSORGUNGSSPANNUNG VOEDINGSSPANNING TENSION DE ALIMENTACIÓN FORSYNINGSSPÆNDING SPENNING STRØMTILFØRSEL MATNINGSSPÄNNING напряжение электропитания 主电压 (V)</p>
--	--	--	--	--

ALIMENTATORE - BALLAST - BALLAST - VORSCHALTGERÄT - VOORSCHAKELAPPARAAT - ALIMENTADOR - STRØMFORSYNINGSENHED - BALLAST - TRÖMFÖRSÖRJNINGSANORDNING
ART BH14 - BH15 **art. 9908 10W Vin=220-240 Vac, 50/60Hz; Vout=24Vdc**

1	4	2830	2	24
1	2,5	1769		
1	1,5	1061		

ALIMENTATORE - BALLAST - BALLAST - VORSCHALTGERÄT - VOORSCHAKELAPPARAAT - ALIMENTADOR - STRØMFORSYNINGSENHED - BALLAST - TRÖMFÖRSÖRJNINGSANORDNING
ART BH14 - BH15 **art. 9909 24W Vin=90-244 Vac, 50/60Hz; Vout=24÷28Vdc**

3	4	1415	2	28
3	2,5	884		
3	1,5	531		

ART BH20 - BH21 - BK36 - BK37 - BK80 - BK81

1	4	2423	2	28
1	2,5	1514		
1	1,5	909		

ART BH16 - BH17

1	4	2306	2	28
1	2,5	1441		
1	1,5	865		

ART BH18 - BH19

1	4	1566	2	28
1	2,5	979		
1	1,5	587		

ART BI11 - BI12

1	4	1676	2	28
1	2,5	1047		
1	1,5	628		

ART BH14 - BH15

art. 9910 72W Vin=196-265 Vac, 50/60Hz; Vout=24÷28Vdc

9	4	472	2	28
9	2,5	295		
9	1,5	177		

ART BH20 - BH21 - BK36 - BK37 - BK80 - BK81

5	4	485	2	28
5	2,5	303		
5	1,5	182		

ART BH16 - BH17

5	4	461	2	28
5	2,5	288		
5	1,5	173		

ART BH22 - BH23 - BK40 - BK41 - BK84 - BK85

2	4	640	2	28
2	2,5	400		
2	1,5	240		

ART BH18 - BH19

3	4	522	2	28
3	2,5	326		
3	1,5	196		

ART BH24 - BH25

1	4	862	2	28
1	2,5	539		
1	1,5	323		

ART BI11 - BI12

3	4	559	2	28
3	2,5	349		
3	1,5	209		

ART BI13 - BI14

2	4	518	2	28
2	2,5	324		
2	1,5	194		

ART BH14 - BH15

art. 9911 96W Vin=196-265 Vac, 50/60Hz; Vout=24÷28Vdc

12	4	354	2	28
12	2,5	221		
12	1,5	133		

ART BH20 - BH21 - BK36 - BK37 - BK80 - BK81

7	4	346	2	28
7	2,5	216		
7	1,5	130		

ART BH16 - BH17

6	4	384	2	28
6	2,5	240		
6	1,5	144		

ART BH22 - BH23 - BK40 - BK41 - BK84 - BK85

3	4	427	2	28
3	2,5	267		
3	1,5	160		

ART BH18 - BH19

4	4	392	2	28
4	2,5	245		
4	1,5	147		

ART BH24 - BH25

2	4	431	2	28
2	2,5	269		
2	1,5	162		

ART BI11 - BI12

4	4	419	2	28
4	2,5	262		
4	1,5	157		

ART BI13 - BI14

3	4	345	2	28
3	2,5	216		
3	1,5	130		

ART BH14 - BH15

art. 9912 240W Vin=88-264 Vac, 50/60Hz; Vout=24÷28Vdc

30	4	142	2	28
30	2,5	88		
30	1,5	53		

ART BH20 - BH21 - BK36 - BK37 - BK80 - BK81

17	4	143	2	28
17	2,5	89		
17	1,5	53		

ART BH16 - BH17

16	4	144	2	28
16	2,5	90		
16	1,5	54		

ART BH22 - BH23 - BK40 - BK41 - BK84 - BK85

9	4	142	2	28
9	2,5	89		
9	1,5	53		

ART BH18 - BH19

11	4	142	2	28
11	2,5	89		
11	1,5	53		

ART BH24 - BH25

6	4	144	2	28
6	2,5	90		
6	1,5	54		

ART BI11 - BI12

12	4	140	2	28
12	2,5	87		
12	1,5	52		

ART BI13 - BI14

7	4	148	2	28
7	2,5	93		
7	1,5	56		

ART BH14 - BH15

art. BZK0 120W Vin=88-264 Vac, 50/60Hz; Vout=24÷28Vdc

15	4	283	2	28
15	2,5	177		
15	1,5	106		

ART BH20 - BH21 - BK36 - BK37 - BK80 - BK81

8	4	303	2	28
8	2,5	189		
8	1,5	114		

ART BH16 - BH17

8	4	288	2	28
8	2,5	180		
8	1,5	108		

ART BH22 - BH23 - BK40 - BK41 - BK84 - BK85

4	4	320	2	28
4	2,5	200		
4	1,5	120		

ART BH18 - BH19

5	4	313	2	28
5	2,5	196		
5	1,5	117		

ART BH24 - BH25

3	4	287	2	28
3	2,5	180		
3	1,5	108		

ART BI11 - BI12

6	4	279	2	28
6	2,5	175		
6	1,5	105		

ART BI13 - BI14

3	4	345	2	28
3	2,5	216		
3	1,5	130		

ART BH14 - BH15

art. BZK1 480W Vin=90-264 Vac, 50/60Hz; Vout=24÷28Vdc

60	4	70	2	28
	2,5	58		
	1,5	53		

ART BH20 - BH21 - BK36 - BK37 - BK80 - BK81

35	4	69	2	28
	2,5	58		
	1,5	53		

ART BH16 - BH17

33	4	69	2	28
	2,5	57		
	1,5	54		

ART BH22 - BH23 - BK40 - BK41 - BK84 - BK85

18	4	71	2	28
	2,5	61		
	1,5	53		

ART BH18 - BH19

22	4	71	2	28
	2,5	57		
	1,5	53		

ART BH24 - BH25

12	4	71	2	28
	2,5	59		
	1,5	53		

ART BI11 - BI12

24	4	69	2	28
	2,5	58		
	1,5	52		

ART BI13 - BI14

15	4	69	2	28
	2,5	58		
	1,5	55		

ART BH14 - BH15

art. X182 40W Vin=90-305 Vac, 47/63Hz; Vout=22÷27Vdc

5	4	565	2	27
	2,5	350		
	1,5	210		

ART BH20 - BH21 - BK36 - BK37 - BK80 - BK81

2	4	805	2	27
	2,5	505		
	1,5	300		

ART BH16 - BH17

2	4	765	2	27
	2,5	480		
	1,5	285		

ART BH22 - BH23 - BK40 - BK41 - BK84 - BK85

1	4	850	2	27
	2,5	530		
	1,5	320		

ART BH18 - BH19

1	4	1040	2	27
	2,5	650		
	1,5	390		

ART BH24 - BH25

1	4	575	2	27
	2,5	355		
	1,5	215		

ART BI11 - BI12

2	4	555	2	27
	2,5	345		
	1,5	205		

ART BI13 - BI14

1	4	690	2	27
	2,5	430		
	1,5	252		

ART BH14 - BH15

art. X183 80W Vin=90-305 Vac, 47/63Hz; Vout=22÷27Vdc

10	4	280	2	27
	2,5	175		
	1,5	105		

ART BH20 - BH21 - BK36 - BK37 - BK80 - BK81

5	4	320	2	27
	2,5	200		
	1,5	120		

ART BH16 - BH17

5	4	305	2	27
	2,5	190		
	1,5	115		

ART BH22 - BH23 - BK40 - BK41 - BK84 - BK85

3	4	285	2	27
	2,5	175		
	1,5	105		

ART BH18 - BH19

3	4	345	2	27
	2,5	215		
	1,5	130		

ART BH24 - BH25

2	4	285	2	27
	2,5	175		
	1,5	105		

ART BI11 - BI12

4	4	275	2	27
	2,5	170		
	1,5	105		

ART BI13 - BI14

2	4	345	2	27
	2,5	215		
	1,5	125		

ART BH14 - BH15

art. X184 120W Vin=90-305 Vac, 47/63Hz; Vout=22÷27Vdc

15	4	185	2	27
	2,5	115		
	1,5	70		

ART BH20 - BH21 - BK36 - BK37 - BK80 - BK81

8	4	200	2	27
	2,5	125		
	1,5	75		

ART BH16 - BH17

8	4	190	2	27
	2,5	120		
	1,5	70		

ART BH22 - BH23 - BK40 - BK41 - BK84 - BK85

4	4	210	2	27
	2,5	130		
	1,5	80		

ART BH18 - BH19

5	4	205	2	27
	2,5	130		
	1,5	75		

ART BH24 - BH25

3	4	190	2	27
	2,5	120		
	1,5	70		

ART BI11 - BI12

6	4	185	2	27
	2,5	115		
	1,5	70		

ART BI13 - BI14

3	4	230	2	27
	2,5	140		
	1,5	85		

ART BH14 - BH15

art. X185 185W Vin=90-305 Vac, 47/63Hz; Vout=22÷27Vdc

23	4	120	2	27
	2,5	75		
	1,5	45		

ART BH20 - BH21 - BK36 - BK37 - BK80 - BK81

13	4	120	2	27
	2,5	75		
	1,5	45		

ART BH16 - BH17

12	4	125	2	27
	2,5	80		
	1,5	45		

ART BH22 - BH23 - BK40 - BK41 - BK84 - BK85

7	4	120	2	27
	2,5	75		
	1,5	45		

ART BH18 - BH19

8	4	130	2	27
	2,5	80		
	1,5	45		

ART BH24 - BH25

4	4	140	2	27
	2,5	90		
	1,5	50		

ART BI11 - BI12

9	4	120	2	27
	2,5	75		
	1,5	45		

ART BI13 - BI14

5	4	135	2	27
	2,5	85		
	1,5	50		

ART BH14 - BH15

art. X186 240W Vin=90-305 Vac, 47/63Hz; Vout=22÷27Vdc

30	4	90	2	27
	2,5	55		
	1,5	35		

ART BH20 - BH21 - BK36 - BK37 - BK80 - BK81

17	4	95	2	27
	2,5	55		
	1,5	35		

ART BH16 - BH17

16	4	95	2	27
	2,5	60		
	1,5	35		

ART BH22 - BH23 - BK40 - BK41 - BK84 - BK85

9	4	95	2	27
	2,5	55		
	1,5	35		

ART BH18 - BH19

11	4	95	2	27
	2,5	55		
	1,5	35		

ART BH24 - BH25

6	4	95	2	27
	2,5	60		
	1,5	35		

ART BI11 - BI12

12	4	90	2	27
	2,5	55		
	1,5	35		

ART BI13 - BI14

7	4	95	2	27
	2,5	60		
	1,5	35		

art. X187 320W Vin=90-305 Vac, 47/63Hz; Vout=22÷27Vdc

ART BH14 - BH15

41	4	65	2	27
	2,5	40		
	1,5	25		

ART BH20 - BH21 - BK36 - BK37 - BK80 - BK81

23	4	70	2	27
	2,5	40		
	1,5	25		

ART BH16 - BH17

22	4	70	2	27
	2,5	40		
	1,5	25		

ART BH22 - BH23 - BK40 - BK41 - BK84 - BK85

12	4	70	2	27
	2,5	40		
	1,5	25		

ART BH18 - BH19

15	4	70	2	27
	2,5	40		
	1,5	25		

ART BH24 - BH25

8	4	70	2	27
	2,5	45		
	1,5	25		

ART BI11 - BI12

16	4	70	2	27
	2,5	40		
	1,5	25		

ART BI13 - BI14

10	4	65	2	27
	2,5	40		
	1,5	25		

DIMMING VERSION

DALI ⚠

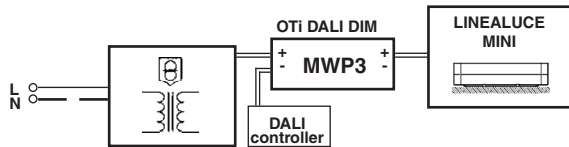

DALI ⚠

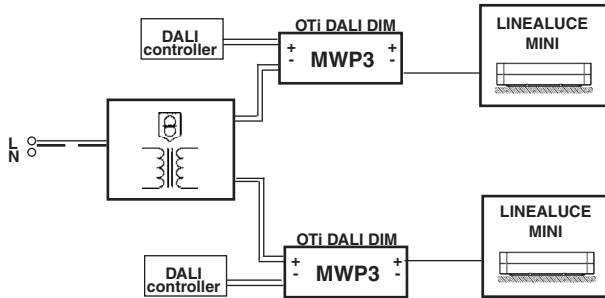

TOUCH DIM ⚠

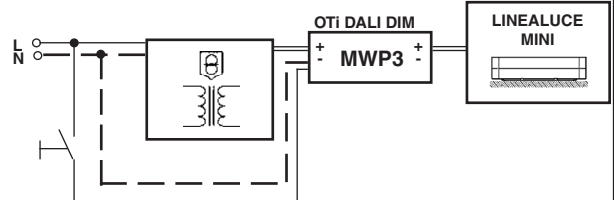

TOUCH DIM ⚠

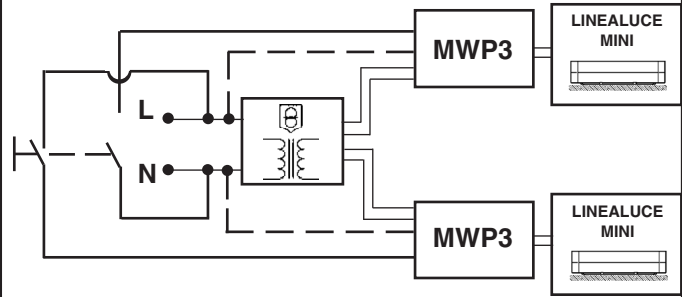

<p>n° prodotti no. of products nbre de produits Anz. Produkte Aantal producten Cantidad de productos Anal produkter Antall produkter Antal produkter кол-во изделий 产品数量</p> 	<p>SEZIONE DEL CAVO ESTERNO EXTERNAL WIRE CROSS-SECTION SECTION DU CÂBLE EXTÉRIEUR QUERSCHNITT DES AUBENKABELS DOORSNEDE VAN DE EXTERNE KABEL SECCIÓN DEL CABLE EXTERNO SNIT PÅ EKSTERN LEDNING TVERRSNITT AV YTRE LEDNING TVÅRSNITT FÖR EXTERN KABEL сечение внешнего провода 外部电缆部分 (mm²)</p>	<p>LUNGHEZZA MASSIMA DEL CAVO DALL'ALIMENTATORE ALLA SCATOLA DI DERIVAZIONE MAXIMUM LENGTH OF POWER SUPPLY CABLE TO JUNCTION BOX LONGUEUR MAXIMALE DU CÂBLE DU BALLAST À LA BOÎTE DE DÉRIVATION MAXIMALE LÄNGE DES KABELS VOM VORSCHALTGERÄT ZUR ABZWEIGDOSE MAXIMALE LENGTE VAN DE KABEL VANAF HET VOORSCHAKELAPPARAAT NAAR DE AFTAKDOOS LONGITUD MÁXIMA DEL CABLE DE ALIMENTADOR A LA CAJA DE DERIVACIÓN MAKS. LÆNGDE PÅ STRØMFORSYNINGSLIGNING TIL SAMLEDÅSE MAKSIMAL LENGDE TIL KABELN TIL TRANSFORMATOREN TIL KOBLINGSBOKSEN MAX. LÅNGD FÖR KABELN FRÅN STRÖMFÖRSÖRJNINGSANORDNINGEN TILL KOPPLINGSDOSAN Максимальная длина кабеля от распределительной коробки 从接线盒的电缆最大长度 Lc^(m)</p>	<p>LUNGHEZZA MASSIMA DEL CAVO (1 mm²) DALLA SCATOLA DI DERIVAZIONE AI PRODOTTI MAXIMUM LENGTH OF THE CABLE (1 mm²) FROM THE CONNECTOR BLOCK TO THE PRODUCTS LONGUEUR MAXIMALE DU CÂBLE (1 mm²) DE LA BOÎTE DE DÉRIVATION AUX PRODUITS MAXIMALE LÄNGE DES KABELS (1 mm²) VON DER ABZWEIGDOSE ZU DEN PRODUKTEN MAXIMALE LENGTE VAN DE KABEL (1 mm²) VANAF DE AANSLUITBOX TOT DE PRODUCTEN. LONGITUD MÁXIMA DEL CABLE (1 mm²) DE LA CAJA DE DERIVACIÓN A LOS PRODUCTOS MAKS. LÆNGDE PÅ FORSYNINGSLIGNINGEN (1 mm²) FRA SAMLEDÅSE TIL PRODUKTENE MAKSIMAL LENGDE PÅ KABELN (1 mm²) FRA KOBLINGSBOKSEN TIL PRODUKTENE MAX. KABELLÅNGD (1 mm²) FRÅN KOPPLINGSDOSAN TILL PRODUKTERNA МАКСИМАЛЬНАЯ ДЛИНА ПРОВОДА (1 мм²) ОТ ОТВЕТВИТЕЛЬНОЙ КОРОБКИ ДО ПРИБОРОВ 从连接器插头块到产品的线缆最大长度 (1 MM²) L1</p>	<p>TENSIONE DI ALIMENTAZIONE POWER SUPPLY VOLTAGE TENSION D'ALIMENTATION VERSORGUNGSSPANNUNG VOEDINGSSPANNING TENSION DE ALIMENTACIÓN FORSYNINGSSPÆNDING SPENNING STRØMTILFØRSEL MATNINGSSPÄNNING напряжение электропитания 主电压 (V)</p>
--	--	--	---	--

ALIMENTATORE - BALLAST - BALLAST - VORSCHALTGERÄT - VOORSCHAKELAPPARAAT - ALIMENTADOR - STRØMFORSYNINGSENHED - BALLAST - TRÖMFÖRSÖRJNINGSANORDNING

ART BH14 - BH15

art. MWP3 50W Vin=10-24 Vdc, 0Hz; Vout=10,5÷24Vdc

17	1,5	50	2	24
----	-----	----	---	----

ART BH20 - BH21 - BK36 - BK37 - BK80 - BK81

9	1,5	50	2	24
---	-----	----	---	----

ART BH16 - BH17

9	1,5	50	2	24
---	-----	----	---	----

ART BH22 - BH23 - BK40 - BK41 - BK84 - BK85

5	1,5	50	2	24
---	-----	----	---	----

ART BH18 - BH19

6	1,5	50	2	24
---	-----	----	---	----

ART BH24 - BH25

3	1,5	50	2	24
---	-----	----	---	----

ART BI11 - BI12

6	1,5	50	2	24
---	-----	----	---	----

ART BI13 - BI14

4	1,5	50	2	24
---	-----	----	---	----

<p>I SE NON SI VOGLIONO RISPETTARE GLI ESEMPI LA MASSIMA CORRENTE UTILIZZANDO IL DIMMER OSRAM (art.MWP3) DEVE ESSERE 4A CONSIDERANDO LA PERDITA DOVUTA DAL CAVO.</p> <p>GB IF THE USER PREFERS NOT TO OBSERVE THE EXAMPLES, THE MAXIMUM CURRENT USING THE OSRAM DIMMER (item MWP3) MUST BE 4 A, TAKING INTO ACCOUNT THE LOSS DUE TO THE CABLE.</p> <p>F SI VOUS NE VOULEZ PAS RESPECTER LES EXEMPLES, LE COURANT MAXIMAL, AVEC UTILISATION D'UN GRADATEUR OSRAM (art.MWP3), DOIT ÊTRE DE 4A EN CONSIDÉRANT LA PERTE DUE AU CÂBLE.</p> <p>D FALLS DIE BEISPIELE NICHT ÜBERNOMMEN WERDEN, DARF DIE HÖCHSTSTROMSTÄRKE BEI VERWENDUNG EINES OSRAM DIMMERS (ART. MWP3) UND UNTER BERÜCKSICHTIGUNG DER KABELVERLUSTE NICHT MEHR ALS 4 A BETRAGEN.</p> <p>NL SI NO SE DESEAN RESPETAR LOS EJEMPLOS, LA CORRIENTE MÁXIMA UTILIZANDO EL DIMMER OSRAM (art.MWP3) DEBE SER 4A, CONSIDERANDO LA DEBIDA PÉRDIDA POR EL CABLE.</p> <p>E HVIS EKSEMPLERNE IKKE OVERHOLDES, SKAL MAKSIMAL STRØMFORSYNING MED LYS/DÆMPEREN OSRAM (art.MWP3) VÆRE 4A UNDER HENSYN TIL STRØMTAB IGENNEM KABEL.</p> <p>DK ALS MEN DE VOORBEELDEN NIET WIL VOLGEN, DAN MOET DE MAXIMALE STROOM BIJ GEBRUIK VAN DE OSRAM-DIMMER (art. MWP3) 4A ZIJN, REKENING HOUDEND MET HET STROOMVERLIES DOOR DE KABEL.</p> <p>N HVIS MAN IKKE OVERHOLDER EKSEMPLERNE, MÅ MAKSIMUMSSTRØMMEN VÆRE 4A NÅR MAN BRUKER OSRAM-DIMMER (art. MWP3), TATT I BETRAKTNING STRØMTAPET FRA LEDNINGEN.</p> <p>S OM MAN INTE VILL RESPEKTERA EXEMPLEN, MÅSTE MAX. STRÖM VID ANVÄNDNING AV OSRAM-DIMMER (art.MWP3) VARA 4 A MED HÄNSYN TILL FÖRLUSTEN PÅ GRUND AV KABELN</p> <p>RUS ЕСЛИ НЕ ПРИДЕРЖИВАТЬСЯ ПРИМЕРОВ, МАКСИМАЛЬНЫЙ ТОК, С ИСПОЛЬЗОВАНИЕМ РЕГУЛЯТОРА СИЛЫ СВЕТА OSRAM (арт.МWP3), ДОЛЖЕН СОСТАВЛЯТЬ 4 А, УЧИТЫВАЯ ПОТЕРИ В СВЯЗИ С КАБЕЛЕМ.</p> <p>CN 如果用户不愿遵守示范要求，那么鉴于因电缆造成的损耗，使用欧司朗调光器（项目 MWP3）的最小电流必须为 4 A。</p>
--

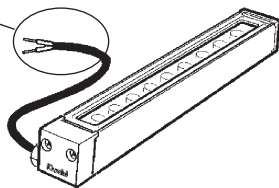
**A**

art. BH14 - BH15
 BH16 - BH17
 BH18 - BH19
 BH20 - BH21
 BH22 - BH23
 BH24 - BH25
 BK36 - BK37
 BK40 - BK41
 BK80 - BK81
 BK84 - BK85
 BI11 - BI12
 BI13 - BI14

I N.B.: Per il collegamento elettrico alla rete (fase A), servirsi degli art. BZK7 o di altri dispositivi di connessione che garantiscano il grado di protezione IP66.

GB N.B.: To make the connection to the mains (step A), use art. BZK7 or other connection devices which guarantee an IP66 degree of protection.

F N.B.: Pour le raccordement électrique a la ligne (phase A), servez-vous de l'art. BZK7 ou bien d'autres dispositifs de connexion garantissant l'indice de protection IP66.

D N.B.: Der Anschluß an das Stromnetz (Phase A), ist mittels der Artikel BZK7 oder anderen Anschlußvorrichtungen , die den Schutzgrad IP66 gewährleisten, vorzunehmen.

NL N.B.: Voor de elektrische aansluiting aan het net (fase A), maakt u gebruik van art. BZK7 of andere aansluitingssystemen die de protectiegraad IP66 garanderen.

E NOTA: Para efectuar el enlace a la red eléctrica (fase A), utilizar los art. BZK7u otros di dispositivos de conexión , que garantizan grado de protección IP66.

DK N.B.: For elektrisk tilslutning til forsyningsnettet (fase A) skal man bruge art. BZK7 eller en anden forbindelsesanordning , der garanterer en beskyttelsesgrad lig med IP66.

N N.B.: For å foreta elektriske tilkoplinger til strømmettet (trinn A), bruk artikkel BZK7 eller andre tilkoplingsinnretninger som garanterer en IP66 vernegrad.

S OBS! För anslutningen till elnätet (fas A), använd art. BZK7 eller andra anslutningsanordningar som garanterar skyddsgrad IP66.

RUS ПРИМЕЧАНИЕ: Для подключения к электрической сети (A) используйте артикул BZK7 или другие соединительные устройства класса II, обеспечивающие класс электробезопасности IP66.

CN 注意: 为实现与干线的电路连接 (A), 使用 art. BZK7 或其他可保证 IP66 保护度的 II 级连接装置。

N.B.: DURANTE L'INSTALLAZIONE DEL SISTEMA " LINEALUCE MINI " RISPETTARE SCRUPolosAMENTE LE NORME IMPIANTISTICHE NAZIONALI VIGENTI.

N.B.: WHEN INSTALLING THE " LINEALUCE MINI " SYSTEM, MAKE SURE ALL CURRENT NATIONAL REGULATIONS RELATING TO INSTALLATION ARE OBSERVED.

N.B.: LORS DEL'INSTALLATION DU SYSTÈME " LINEALUCE MINI " VEUILLEZ RESPECTER RIGOREUSEMENT LES NORMES EN VIGUEUR EN LA MATIERE DANS LE PAYS.

N.B.: BEACHTEN SIE BEI DER INSTALLATION DES SYSTEMS " LINEALUCE MINI " UNBEDINGT DIE IM LAND GELTENDEN ANLAGETECHNISCHEN VORSCHRIFTEN.

N.B.: BIJ HET INSTALLEREN VAN HET " LINEALUCE MINI " SYSTEEM MOET U DE GELDENDE NATIONALE INSTALLATIENORMEN STRIKT NALEVEN.

NOTA: DURANTE LA INSTALACIÓN DEL SISTEMA " LINEALUCE MINI " RESPETAR SCRUPulosAMENTE LAS NORMAS NACIONALES DE INSTALACION EN VIGOR.

N.B.: UNDER INSTALLATION AF " LINEALUCE MINI " SYSTEMET SKAL MAN NØJE OVERHOLDE DE GÆLDENDE REGLER FOR DISSE ANLÆG.

N.B.: UNDER INSTALLASJON AV SYSTEMET " LINEALUCE MINI " MÅ DE NASJONALE ANLEGGSFORSKRIFTENE OVERHOLDES NØYE.

OBS! UNDER INSTALLATIONEN AV SYSTEMET " LINEALUCE MINI " SKA GÅLLANDE NATIONELLA INSTALLATIONSFORESKRIFTER RESPEKTERAS I DETALJ.

ПРИМЕЧАНИЕ: В ПРОЦЕССЕ МОНТАЖА СИСТЕМЫ " LINEALUCE MINI " СТРОГО СОБЛЮДАЙТЕ НАЦИОНАЛЬНЫЕ ДЕЙСТВУЮЩИЕ НОРМАТИВЫ ПО ЭЛЕКТРОПРОВОДКЕ.

重要: 安装 " LINEALUCE MINI " 系统时请始终参照标准系统

I N.B.: Per la sostituzione del LED contattare l'azienda iGuzzini.

GB N.B.: For information on LED replacement please contact iGuzzini.

F N.B.: Pour procéder au remplacement de la LED, adressez-vous à la société iGuzzini.

D Ñ.B.: Bezüglich des Austausches der LED kontaktieren Sie bitte die Firma iGuzzini.

NL N.B.: Voor het vervangen van de LED neemt u contact op met het bedrijf iGuzzini.

E NOTA: Para sustituir el LED llame a la empresa iGuzzini.

DK N.B.: For udskiftning af lysdioden, skal man kontakte iGuzzini.

N N.B.: For informasjon om skifte av LED, vennligst ta kontakt med iGuzzini.

S OBS! För byte av lysdioden, kontakta företaget iGuzzini.

RUS ПРИМЕЧАНИЕ: Для замены СИДов обращайтесь в компанию iGuzzini.

CN 注意: 如需LED更换的信息, 请联系iGuzzini.

I In caso di danneggiamento del cavo flessibile esterno, questo deve essere sostituito dal costruttore, o dal suo servizio di assistenza, o da personale qualificato equivalente, al fine di evitare pericoli.

GB Should the outer flexible cable be somehow damage, the latter should be replaced by the manufacturer, or by the corresponding service centre, or by an appropriate and qualified member of staff in order to avoid all risk of danger.

F Si le câble flexible extérieur est abîmé, faites-le remplacer par le fabricant, par son service après-vente ou par un professionnel du secteur agréé afin d'éviter tout danger.

D Sollte das äußere Kabel beschädigt sein, so muss es aus Sicherheitsgründen vom Hersteller, dessen Kundendienst oder von dazu autorisiertem Personal ausgewechselt werden.

NL Mocht de externe flexibele slang beschadigd worden, dan moet deze worden vervangen door de fabrikant of door een bevoegde installateur, zodat eventueel gevaar vermeden wordt.

E En caso de daños el cable flexible externo debe substituirse por el fabricante, su servicio de asistencia o personal calificado equivalente para evitar peligros.

DK Hvis den yderste ledning beskadiges, skal den udskiftes af producenten eller er et autoriseret teknisk servicecenter, eller af kvalificerede fagfolk, så man undgår farlige situationer.

N Hvis ytre fleksible kabel skulle bli skadet, skal denne skiftes ut av produsenten eller tilsvarende servicesenter eller av en egnet og kvalifisert fagperson for å unngå farerisiko.

S Om den yttre kabeln skadas ska den bytas ut av tillverkaren, av dess auktoriserade verkstad eller av likvärdig kvalificerad personal för att undvika alla typer av risker.

RUS В случае повреждения внешнего гибкого кабеля во избежание риска поручите его замену производителю, уполномоченному сервису или квалифицированному электрику.

CN 如果外部软缆损坏, 须由生产商、对应服务中心或能胜任和资深的员工更换新的电缆, 以避免任何可能的危险。



I In caso di rottura del vetro il prodotto non può essere utilizzato, contattare il costruttore per la sua sostituzione.

GB Should the glass break, the product cannot be used and you should contact the manufacturer for its replacement.

F En cas d'endommagement de l'écran de protection le produit ne peut pas être utilisé, contactez le fabricant pour le remplacement.

D Falls das Glas kaputt sein sollte, kann das Produkt nicht verwendet werden. Kontaktieren Sie in dem Fall den Hersteller, um das Glas zu ersetzen.

NL Als het glas gebroken is kan het apparaat niet worden gebruikt en moet u zich tot de fabrikant wenden voor het vervangen van het glas.

E No utilizar el producto en caso de ruptura del vidrio y contactar el fabricante para la sustitución.

DK Hvis produktets glas ødelægges, kan det ikke anvendes. Kontakt forhandleren med henblik på udskiftning.

N Hvis glasset skulle knuses, kan ikke produktet brukes, og du må ta kontakt med produsenten for å få det skiftet.

S Om glaset går sönder kan inte produkten användas. Kontakta tillverkaren för att byta ut glaset.

RUS В случае разбивания стекла не используйте прибор, обратитесь к его производителю для замены.

CN 且玻璃破碎后产品将不能再使用, 须联系生产商予以更换。

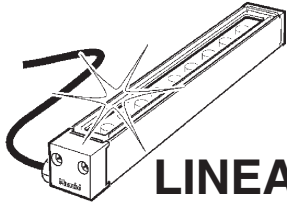

LINEALUCE MINI 37R MONOCHROME (PWM)

تحذير :

لا يمكن ضمان سلامة هذا الجهاز إلا إذا التزمت بهذه التعليمات. يجب حفظها في مكان آمن.

ATTENZIONE:

LA SICUREZZA DELL'APPARECCHIO E' GARANTITA SOLO CON L'USO APPROPRIATO DELLE SEGUENTI ISTRUZIONI; PERTANTO E' NECESSARIO CONSERVARLE.

WARNING:

THE SAFETY OF THIS FIXTURE IS GUARANTEED ONLY IF YOU COMPLY WITH THESE INSTRUCTIONS; REMEMBER TO CONSERVE IN A SAFE PLACE.

ATENCION:

LA SEGURIDAD DEL APARATO SE GARANTIZA SOLO CUMPLIENDO CUIDADOSAMENTE LAS SIGUIENTES INSTRUCCIONES; POR ELLO, ES NECESARIO CONSERVARLAS.

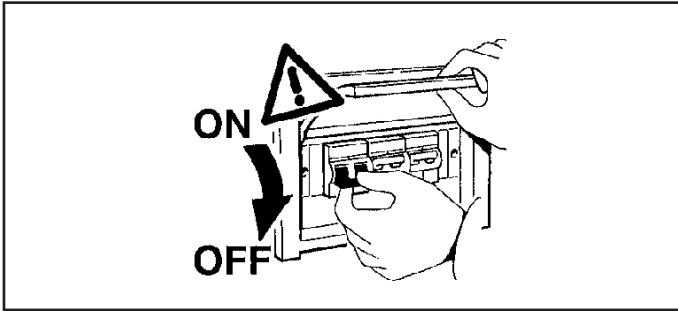

الصنف	ART.	ملم
		L (mm)
BH14 - BH15 - BH20 - BH21 BK36 - BK37 - BK80 - BK81		528
BI11 - BI12		792
BH16 - BH17 - BH22 - BH23 BK40 - BK41 - BK84 - BK85		1056
BI13 - BI14		1321
BH18 - BH19 - BH24 - BH25		1585

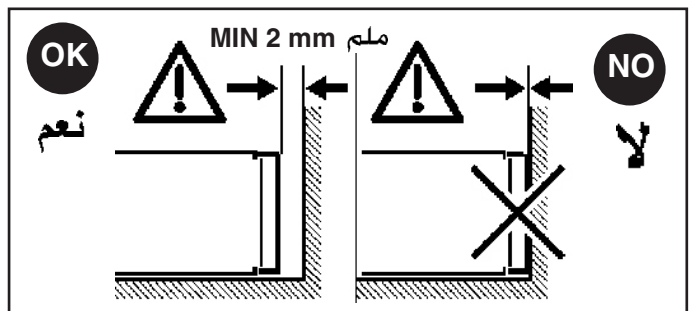
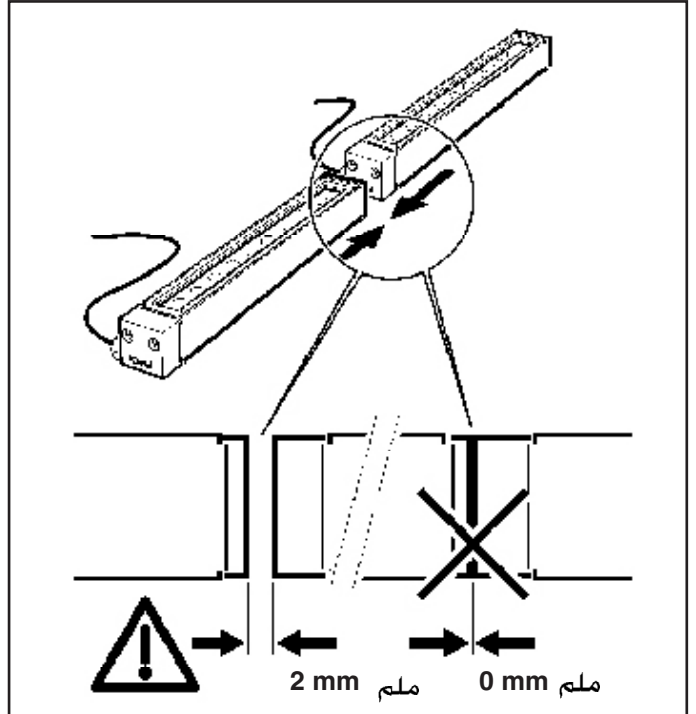
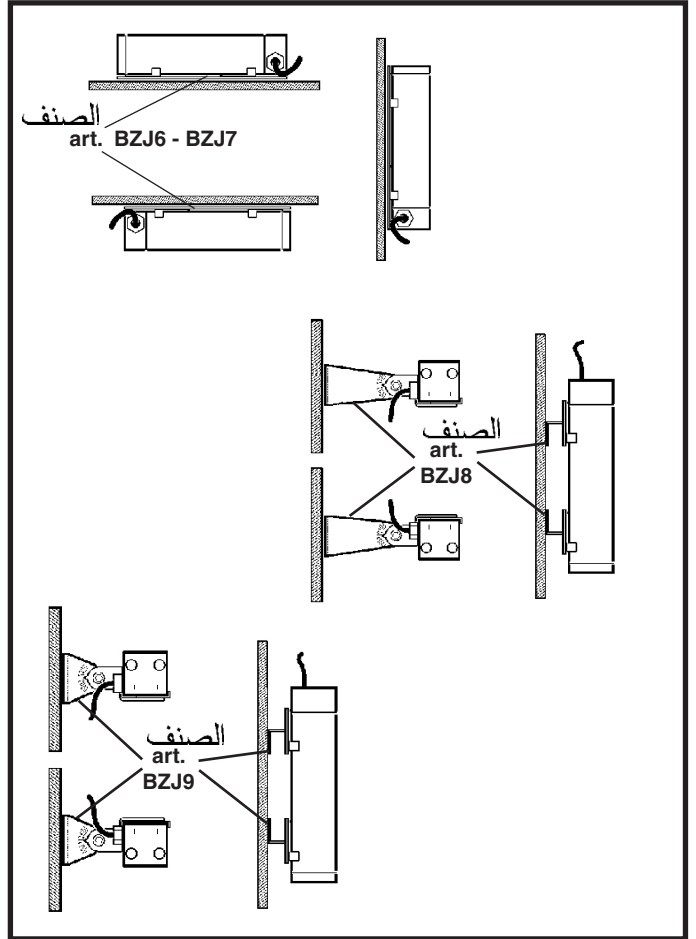
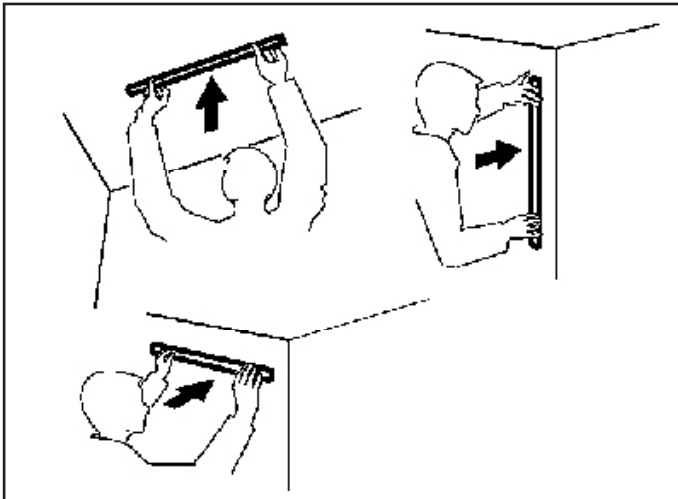

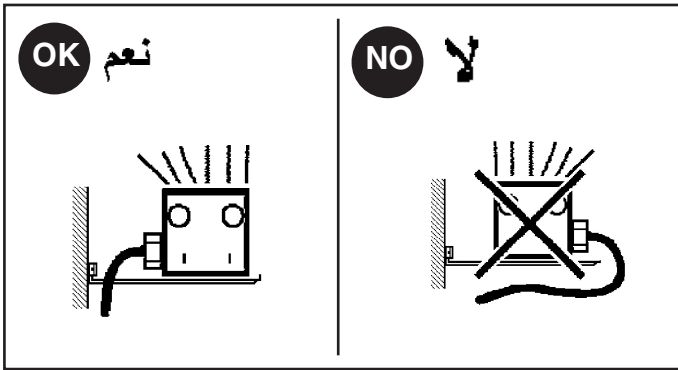

تركيب الدعائم الميكانيكية

INSTALLAZIONE DEI SUPPORTI MECCANICI
 INSTALLATION OF THE MECHANICAL SUPPORTS
 INSTALACIÓN DE LOS SOPORTES MECÁNICOS

جدول مسافات الفتحات من المركز للمركز

TABELLA INTERASSI DI FORATURA
 TABLE - CENTRE TO CENTRE DISTANCE BETWEEN HOLES
 TALADRAR DISTANCIA ENTRE LOS EJES DE PERFORACIÓN

الصف ART.	BZJ8 BZJ9 K (mm) ملم	BZJ6 K (mm) ملم	BZJ7 K (mm) ملم
BH14 - BH15 - BH20 - BH21 - BK36 BK37 - BK80 - BK81	220		
BI11 - BI12		265	/
BH16 - BH17 - BH22 - BH23 - BK40 BK41 - BK84 - BK85	400		
BI13 - BI14			600
BH18 - BH19 - BH24 - BH25		/	

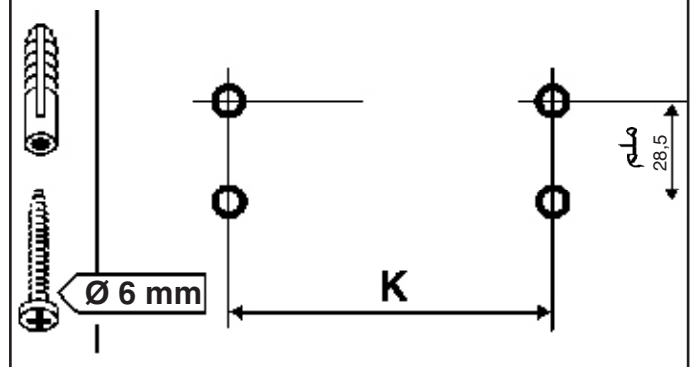
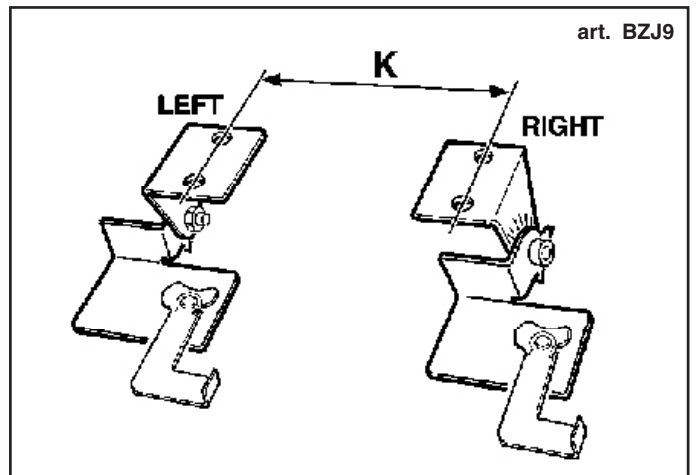
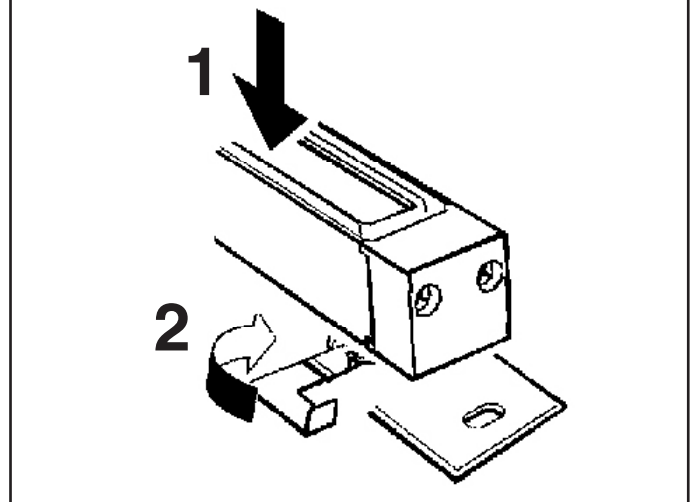
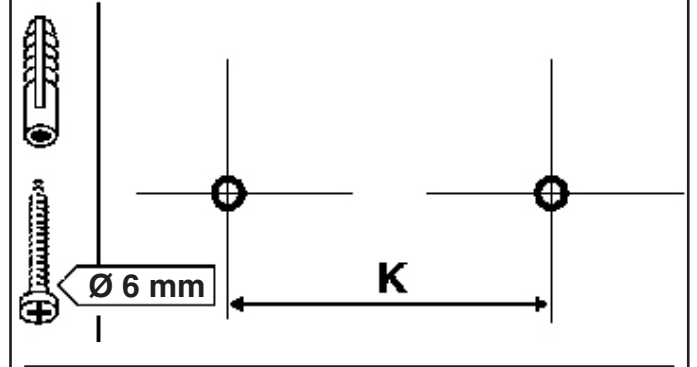
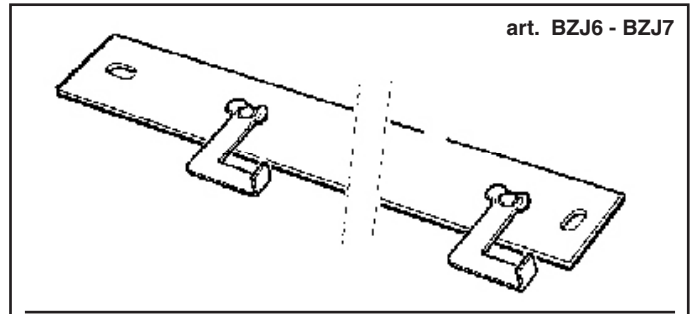
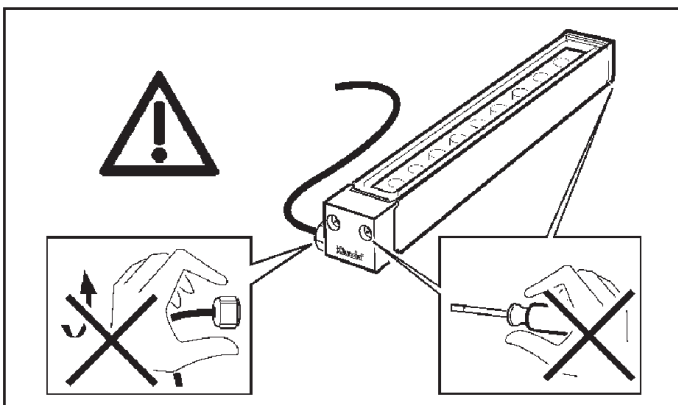
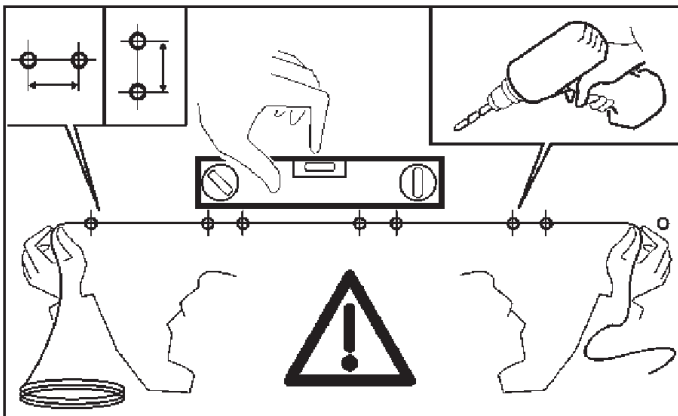

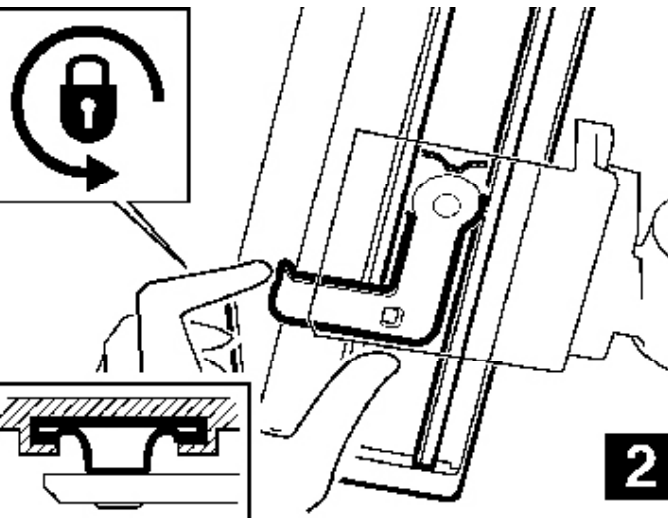
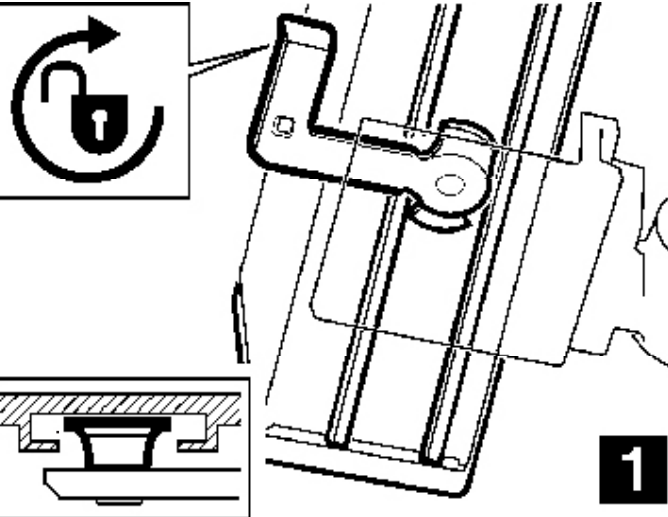
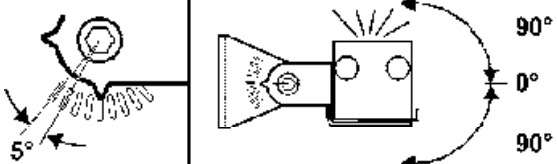
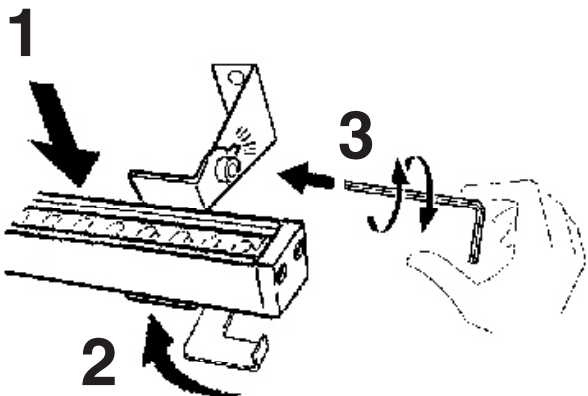

art. BZJ8

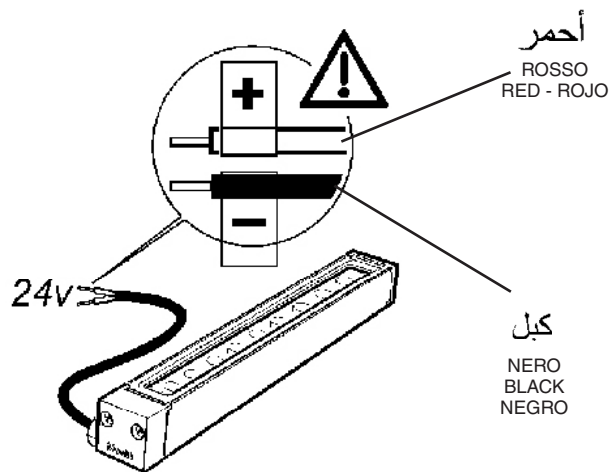
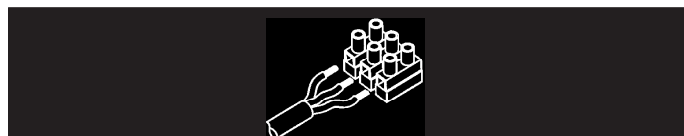
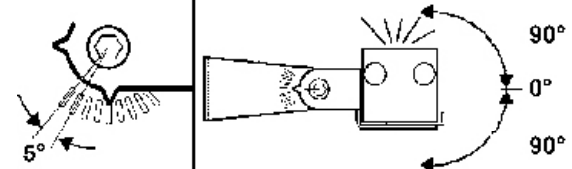
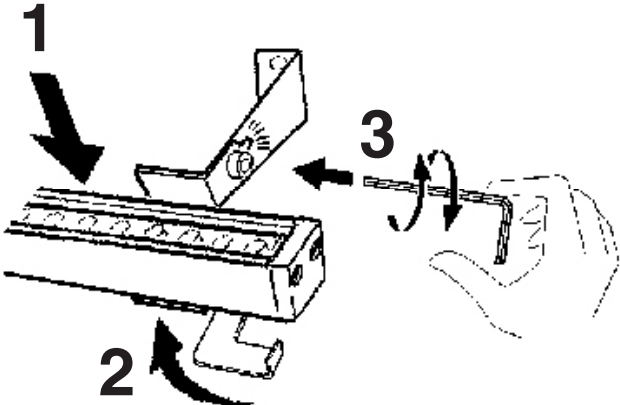
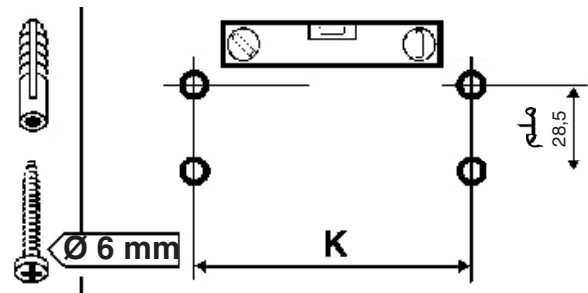
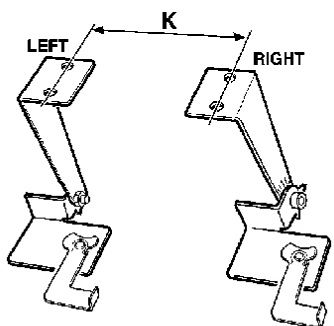

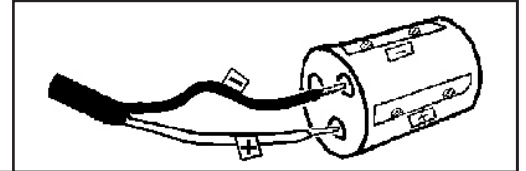
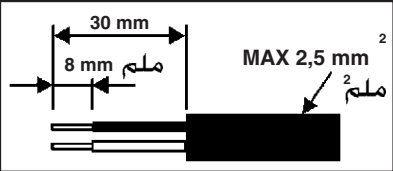
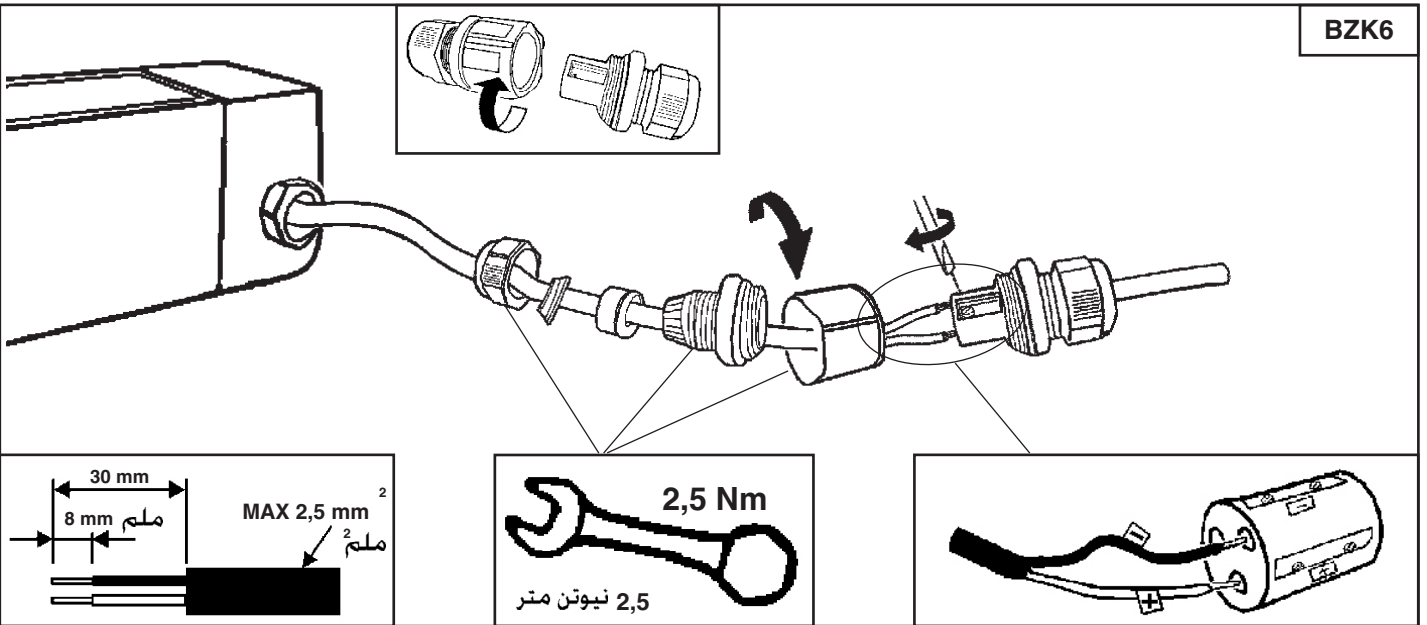

<p>D (mm) مم</p>	
<p>6,5 ÷ 8 mm مم</p>	
<p>8 ÷ 9 mm مم</p>	
<p>9 ÷ 13 mm مم</p>	

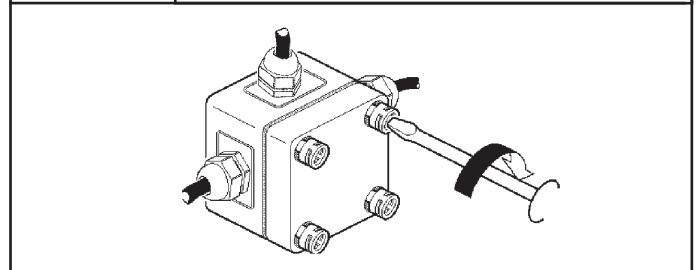
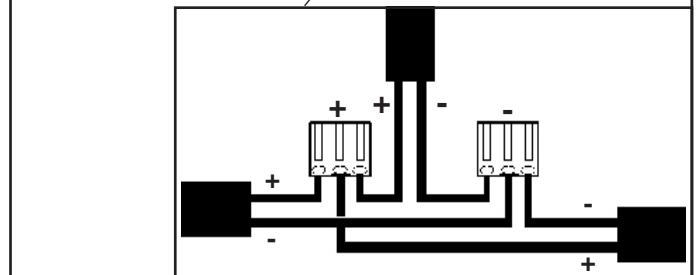
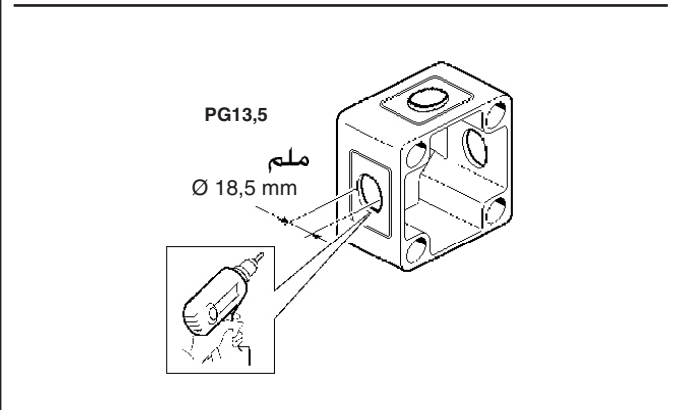
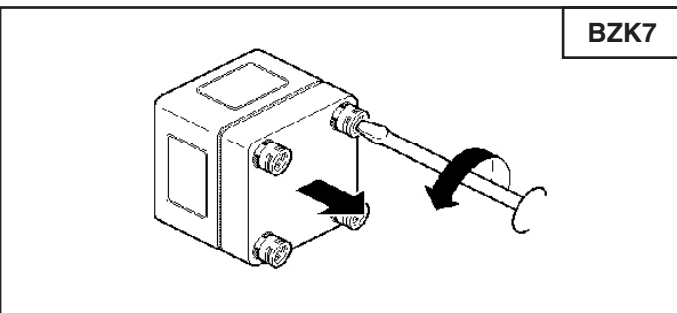
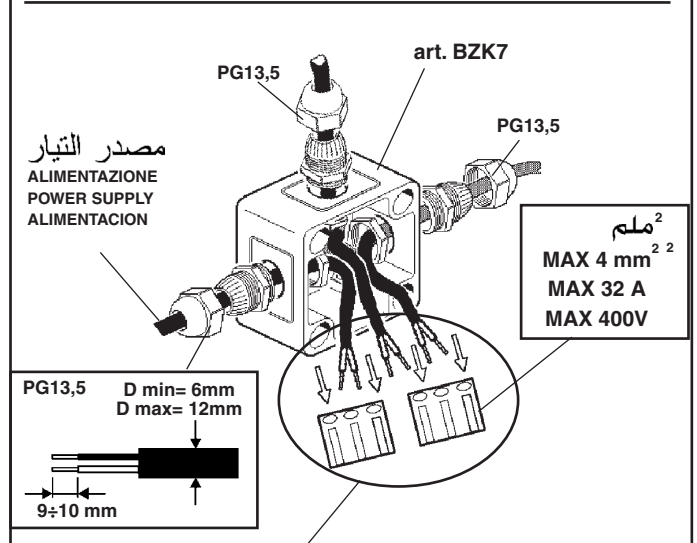
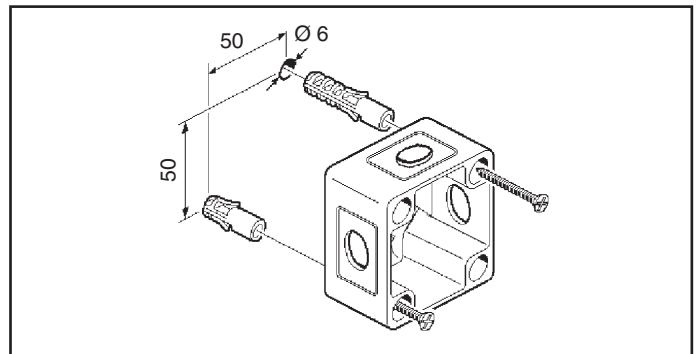

مثال ESEMPIO - EXAMPLE

EJEMPLO

art. BZK0 - BZK1 - 9908 - 9909 - 9910 - 9911 - 9912
X182 - X183 - X184 - X185 - X186 - X187

BZK7

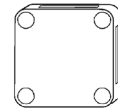

BZK6

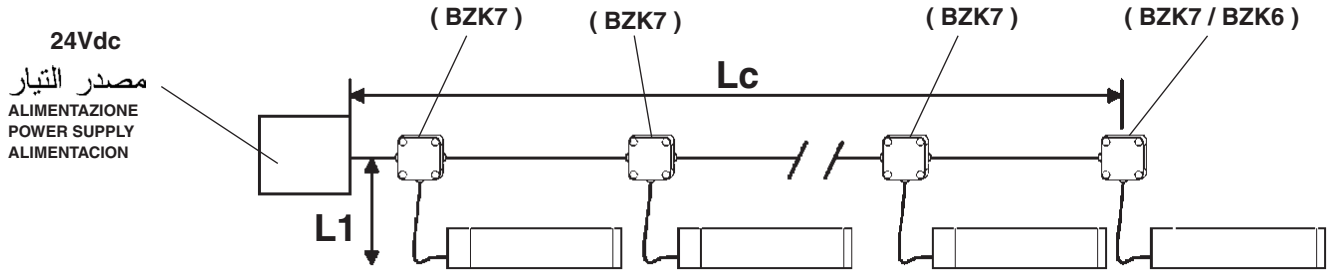
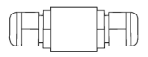

NO DIMMING VERSION

الأنواع غير القابلة لخفض الإضاءة

حساب أقصى طول للكابل:

- I Per calcolare la lunghezza del cavo Max:
- GB To calculate the max length of the cable:
- E Para calcular la longitud del cable Máx:

$$LC[m] = \frac{\Delta x[V] * Sc[mm^2]}{2 * Np * I [A] * 0,0174}$$

لضمان الحد الأدنى من الجهد التشغيلي، يجب أن يكون الحد الأقصى لطول الكابل المستخدم (Sc) 16م.م.

- I PER GARANTIRE IL CORRETTO FUNZIONAMENTO LA TENSIONE MINIMA SUL PRODOTTO AL 100%, CIOE' SENZA DIMMERAZIONE, DEVE ESSERE 16V.
- GB TO ENSURE CORRECT OPERATION, THE MINIMUM VOLTAGE ON THE PRODUCT AT 100% - THAT IS, WITHOUT DIMMING - MUST BE 16 V.
- E PARA GARANTIZAR EL FUNCIONAMIENTO CORRECTO LA TENSION MÍNIMA SOBRE EL PRODUCTO AL 100%, ES DECIR, SIN DIMMER, DEBE SER 16V.

انخفاض التيار المقبول بين وحدة التغذية وأدنى جهد لتشغيل المنتج.

- Δx = Caduta di tensione ammissibile tra alimentatore e la tensione minima di funzionamento del prodotto
- Δx = Allowed voltage drop between the power-supply unit and minimum operating voltage of the product
- Δx = Caída de tensión permitida entre el alimentador y la tensión mínima de funcionamiento del producto

مثال

ESEMPIO - EXAMPLE
EJEMPLO

Power-supply voltage = 28V

Minimum product voltage = 16V



$$\Delta x = 28-16=12V$$

حدد أقصى عدد للمنتجات (Np) وفقاً لمقطع الكابل المستخدم (Sc).

- I Definire il numero di prodotti Max. (Np) in funzione della sezione del cavo utilizzata (Sc).
- GB Define the max number of products (Np) based on the cable section used (Sc).
- E Definir el número de productos Máx. (Np) en función de la sección del cable utilizada (Sc).

عدد المنتجات	مقطع الكابل الخارجي	أقصى طول للكابل من قابس الشحن إلى علبة التحويل	أقصى طول للكابل (1,5 م مربع) من علبة التحويل إلى المنتجات	جهد التغذية
n° prodotti no. of products Cantidad de productos	SEZIONE DEL CAVO ESTERNO EXTERNAL WIRE CROSS-SECTION SECCIÓN DEL CABLE EXTERNO	LUNGHEZZA MASSIMA DEL CAVO DALL'ALIMENTATORE ALLA SCATOLA DI DERIVAZIONE MAXIMUM LENGTH OF POWER SUPPLY CABLE TO JUNCTION BOX LONGITUD MÁXIMA DEL CABLE DE ALIMENTADOR A LA CAJA DE DERIVACIÓN	LUNGHEZZA MASSIMA DEL CAVO (1 mm ²) DALLA SCATOLA DI DERIVAZIONE AI PRODOTTI MAXIMUM LENGTH OF THE CABLE (1 mm ²) FROM THE CONNECTOR BLOCK TO THE PRODUCTS LONGITUD MÁXIMA DEL CABLE (1 mm ²) DE LA CAJA DE DERIVACIÓN A LOS PRODUCTOS	TENSIONE DI ALIMENTAZIONE POWER SUPPLY TENSION DE ALIMENTACIÓN
	(mm ²)	م LC (m)	L1	(V)

كابل ALIMENTATORE - BALLAST - ALIMENTADOR

ART BH14 - BH15

art. 9908 10W Vin=220-240 Vac, 50/60Hz; Vout=24Vdc

1	4	2830	2	24
1	2,5	1769		
1	1,5	1061		

عدد المنتجات n° prodotti no. of products Cantidad de productos	مقطع الكابل الخارجي SEZIONE DEL CAVO ESTERNO EXTERNAL WIRE CROSS-SECTION SECCIÓN DEL CABLE EXTERNO	أقصى طول للكابل من قابس الشحن إلى علبة التحويل LUNGHEZZA MASSIMA DEL CAVO DALL'ALIMENTATORE ALLA SCATOLA DI DERIVAZIONE MAXIMUM LENGTH OF POWER SUPPLY CABLE TO JUNCTION BOX LONGITUD MÁXIMA DEL CABLE DE ALIMENTADOR A LA CAJA DE DERIVACIÓN	أقصى طول للكابل (1,5 م مربع) من علبة التحويل إلى المنتجات LUNGHEZZA MASSIMA DEL CAVO (1 mm ²) DALLA SCATOLA DI DERIVAZIONE AI PRODOTTI MAXIMUM LENGTH OF THE CABLE (1 mm ²) FROM THE CONNECTOR BLOCK TO THE PRODUCTS LONGITUD MÁXIMA DEL CABLE (1 mm ²) DE LA CAJA DE DERIVACIÓN A LOS PRODUCTOS	جهد التغذية TENSIONE DI ALIMENTAZIONE POWER SUPPLY TENSION DE ALIMENTACIÓN
	(mm ²)	م Lc (m)	L1	(V)

كابل ALIMENTATORE - BALLAST - ALIMENTADOR

ART BH14 - BH15

art. 9908 10W Vin=220-240 Vac, 50/60Hz; Vout=24Vdc

1	4	2830	2	24
1	2,5	1769		
1	1,5	1061		

كابل ALIMENTATORE - BALLAST - ALIMENTADOR

ART BH14 - BH15

art. 9909 24W Vin=90-244 Vac, 50/60Hz; Vout=24÷28Vdc

3	4	1415	2	28
3	2,5	884		
3	1,5	531		

ART BH20 - BH21 - BK36 - BK37 - BK80 - BK81

1	4	2423	2	28
1	2,5	1514		
1	1,5	909		

ART BH16 - BH17

1	4	2306	2	28
1	2,5	1441		
1	1,5	865		

ART BH18 - BH19

1	4	1566	2	28
1	2,5	979		
1	1,5	587		

ART BI11 - BI12

1	4	1676	2	28
1	2,5	1047		
1	1,5	628		

كاج ALIMENTATORE - BALLAST - ALIMENTADOR

ART BH14 - BH15

art. 9910 72W Vin=196-265 Vac, 50/60Hz; Vout=24÷28Vdc

9	4	472	2	28
9	2,5	295		
9	1,5	177		

ART BH20 - BH21 - BK36 - BK37 - BK80 - BK81

5	4	485	2	28
5	2,5	303		
5	1,5	182		

ART BH16 - BH17

5	4	461	2	28
5	2,5	288		
5	1,5	173		

ART BH22 - BH23 - BK40 - BK41 - BK84 - BK85

2	4	640	2	28
2	2,5	400		
2	1,5	240		

ART BH18 - BH19

3	4	522	2	28
3	2,5	326		
3	1,5	196		

ART BH24 - BH25

1	4	862	2	28
1	2,5	539		
1	1,5	323		

ART BI11 - BI12

3	4	559	2	28
3	2,5	349		
3	1,5	209		

ART BI13 - BI14

2	4	518	2	28
2	2,5	324		
2	1,5	194		

كاج ALIMENTATORE - BALLAST - ALIMENTADOR

ART BH14 - BH15

art. 9911 96W Vin=196-265 Vac, 50/60Hz; Vout=24÷28Vdc

12	4	354	2	28
12	2,5	221		
12	1,5	133		

ART BH20 - BH21 - BK36 - BK37 - BK80 - BK81

7	4	346	2	28
7	2,5	216		
7	1,5	130		

ART BH16 - BH17

6	4	384	2	28
6	2,5	240		
6	1,5	144		

ART BH22 - BH23 - BK40 - BK41 - BK84 - BK85

3	4	427	2	28
3	2,5	267		
3	1,5	160		

ART BH18 - BH19

4	4	392	2	28
4	2,5	245		
4	1,5	147		

ART BH24 - BH25

2	4	431	2	28
2	2,5	269		
2	1,5	162		

ART BI11 - BI12

4	4	419	2	28
4	2,5	262		
4	1,5	157		

ART BI13 - BI14

3	4	345	2	28
3	2,5	216		
3	1,5	130		

كاج ALIMENTATORE - BALLAST - ALIMENTADOR

ART BH14 - BH15

art. 9912 240W Vin=88-264 Vac, 50/60Hz; Vout=24÷28Vdc

30	4	142	2	28
30	2,5	88		
30	1,5	53		

ART BH20 - BH21 - BK36 - BK37 - BK80 - BK81

17	4	143	2	28
17	2,5	89		
17	1,5	53		

ART BH16 - BH17

16	4	144	2	28
16	2,5	90		
16	1,5	54		

ART BH22 - BH23 - BK40 - BK41 - BK84 - BK85

9	4	142	2	28
9	2,5	89		
9	1,5	53		

ART BH18 - BH19

11	4	142	2	28
11	2,5	89		
11	1,5	53		

ART BH24 - BH25

6	4	144	2	28
6	2,5	90		
6	1,5	54		

ART BI11 - BI12

12	4	140	2	28
12	2,5	87		
12	1,5	52		

ART BI13 - BI14

7	4	148	2	28
7	2,5	93		
7	1,5	56		

كاج ALIMENTATORE - BALLAST - ALIMENTADOR

ART BH14 - BH15

art. BZK0 120W Vin=88-264 Vac, 50/60Hz; Vout=24÷28Vdc

15	4	283	2	28
15	2,5	177		
15	1,5	106		

ART BH20 - BH21 - BK36 - BK37 - BK80 - BK81

8	4	303	2	28
8	2,5	189		
8	1,5	114		

ART BH16 - BH17

8	4	288	2	28
8	2,5	180		
8	1,5	108		

ART BH22 - BH23 - BK40 - BK41 - BK84 - BK85

4	4	320	2	28
4	2,5	200		
4	1,5	120		

ART BH18 - BH19

5	4	313	2	28
5	2,5	196		
5	1,5	117		

ART BH24 - BH25

3	4	287	2	28
3	2,5	180		
3	1,5	108		

ART BI11 - BI12

6	4	279	2	28
6	2,5	175		
6	1,5	105		

ART BI13 - BI14

3	4	345	2	28
3	2,5	216		
3	1,5	130		

ART BH14 - BH15

art. BZK1 480W Vin=90-264 Vac, 50/60Hz; Vout=24÷28Vdc

60	4	70	2	28
45	2,5	58		
30	1,5	53		

ART BH20 - BH21 - BK36 - BK37 - BK80 - BK81

35	4	69	2	28
26	2,5	58		
17	1,5	53		

ART BH16 - BH17

33	4	69	2	28
25	2,5	57		
16	1,5	54		

ART BH22 - BH23 - BK40 - BK41 - BK84 - BK85

18	4	71	2	28
13	2,5	61		
9	1,5	53		

ART BH18 - BH19

22	4	71	2	28
17	2,5	57		
11	1,5	53		

ART BH24 - BH25

12	4	71	2	28
9	2,5	59		
6	1,5	53		

ART BI11 - BI12

24	4	69	2	28
18	2,5	58		
12	1,5	52		

ART BI13 - BI14

15	4	69	2	28
11	2,5	58		
7	1,5	55		

ART BH14 - BH15

art. X182 40W Vin=90-305 Vac, 47/63Hz; Vout=22÷27Vdc

5	4	565	2	27
	2,5	350		
	1,5	210		

ART BH20 - BH21 - BK36 - BK37 - BK80 - BK81

2	4	805	2	27
	2,5	505		
	1,5	300		

ART BH16 - BH17

2	4	765	2	27
	2,5	480		
	1,5	285		

ART BH22 - BH23 - BK40 - BK41 - BK84 - BK85

1	4	850	2	27
	2,5	530		
	1,5	320		

ART BH18 - BH19

1	4	1040	2	27
	2,5	650		
	1,5	390		

ART BH24 - BH25

1	4	575	2	27
	2,5	355		
	1,5	215		

ART BI11 - BI12

2	4	555	2	27
	2,5	345		
	1,5	205		

ART BI13 - BI14

1	4	690	2	27
	2,5	430		
	1,5	252		

art. X183 80W Vin=90-305 Vac, 47/63Hz; Vout=22÷27Vdc

ART BH14 - BH15

10	4	280	2	27
	2,5	175		
	1,5	105		

ART BH20 - BH21 - BK36 - BK37 - BK80 - BK81

5	4	320	2	27
	2,5	200		
	1,5	120		

ART BH16 - BH17

5	4	305	2	27
	2,5	190		
	1,5	115		

ART BH22 - BH23 - BK40 - BK41 - BK84 - BK85

3	4	285	2	27
	2,5	175		
	1,5	105		

ART BH18 - BH19

3	4	345	2	27
	2,5	215		
	1,5	130		

ART BH24 - BH25

2	4	285	2	27
	2,5	175		
	1,5	105		

ART BI11 - BI12

4	4	275	2	27
	2,5	170		
	1,5	105		

ART BI13 - BI14

2	4	345	2	27
	2,5	215		
	1,5	125		

art. X184 120W Vin=90-305 Vac, 47/63Hz; Vout=22÷27Vdc

ART BH14 - BH15

15	4	185	2	27
	2,5	115		
	1,5	70		

ART BH20 - BH21 - BK36 - BK37 - BK80 - BK81

8	4	200	2	27
	2,5	125		
	1,5	75		

ART BH16 - BH17

8	4	190	2	27
	2,5	120		
	1,5	70		

ART BH22 - BH23 - BK40 - BK41 - BK84 - BK85

4	4	210	2	27
	2,5	130		
	1,5	80		

ART BH18 - BH19

5	4	205	2	27
	2,5	130		
	1,5	75		

ART BH24 - BH25

3	4	190	2	27
	2,5	120		
	1,5	70		

ART BI11 - BI12

6	4	185	2	27
	2,5	115		
	1,5	70		

ART BI13 - BI14

3	4	230	2	27
	2,5	140		
	1,5	85		

art. X185 185W Vin=90-305 Vac, 47/63Hz; Vout=22÷27Vdc

ART BH14 - BH15

23	4	120	2	27
	2,5	75		
	1,5	45		

ART BH20 - BH21 - BK36 - BK37 - BK80 - BK81

13	4	120	2	27
	2,5	75		
	1,5	45		

ART BH16 - BH17

12	4	125	2	27
	2,5	80		
	1,5	45		

ART BH22 - BH23 - BK40 - BK41 - BK84 - BK85

7	4	120	2	27
	2,5	75		
	1,5	45		

ART BH18 - BH19

8	4	130	2	27
	2,5	80		
	1,5	45		

ART BH24 - BH25

4	4	140	2	27
	2,5	90		
	1,5	50		

ART BI11 - BI12

9	4	120	2	27
	2,5	75		
	1,5	45		

ART BI13 - BI14

5	4	135	2	27
	2,5	85		
	1,5	50		

art. X186 240W Vin=90-305 Vac, 47/63Hz; Vout=22÷27Vdc

ART BH14 - BH15

30	4	90	2	27
	2,5	55		
	1,5	35		

ART BH20 - BH21 - BK36 - BK37 - BK80 - BK81

17	4	95	2	27
	2,5	55		
	1,5	35		

ART BH16 - BH17

16	4	95	2	27
	2,5	60		
	1,5	35		

ART BH22 - BH23 - BK40 - BK41 - BK84 - BK85

9	4	95	2	27
	2,5	55		
	1,5	35		

ART BH18 - BH19

11	4	95	2	27
	2,5	55		
	1,5	35		

ART BH24 - BH25

6	4	95	2	27
	2,5	60		
	1,5	35		

ART BI11 - BI12

12	4	90	2	27
	2,5	55		
	1,5	35		

ART BI13 - BI14

7	4	95	2	27
	2,5	60		
	1,5	35		

ART BH14 - BH15

41	4	65	2	27
	2,5	40		
	1,5	25		

ART BH20 - BH21 - BK36 - BK37 - BK80 - BK81

23	4	70	2	27
	2,5	40		
	1,5	25		

ART BH16 - BH17

22	4	70	2	27
	2,5	40		
	1,5	25		

ART BH22 - BH23 - BK40 - BK41 - BK84 - BK85

12	4	70	2	27
	2,5	40		
	1,5	25		

ART BH18 - BH19

15	4	70	2	27
	2,5	40		
	1,5	25		

ART BH24 - BH25

8	4	70	2	27
	2,5	45		
	1,5	25		

ART BI11 - BI12

16	4	70	2	27
	2,5	40		
	1,5	25		

ART BI13 - BI14

10	4	65	2	27
	2,5	40		
	1,5	25		

DIMMING VERSION

الأنواع القابلة لخفض الإضاءة

DALI ⚠

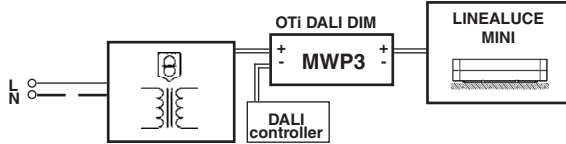

DALI ⚠

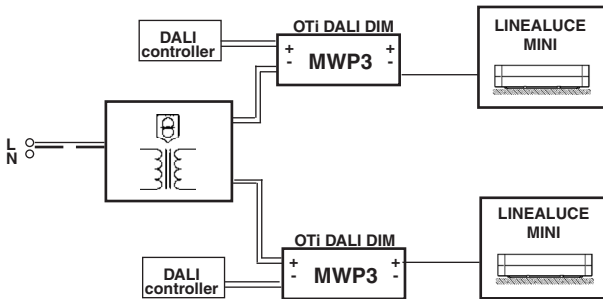

TOUCH DIM ⚠

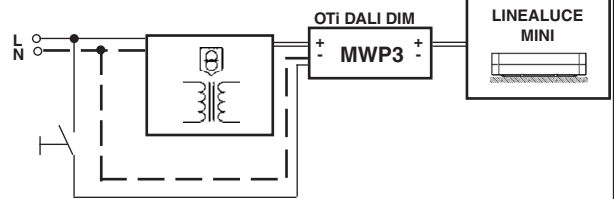

TOUCH DIM ⚠

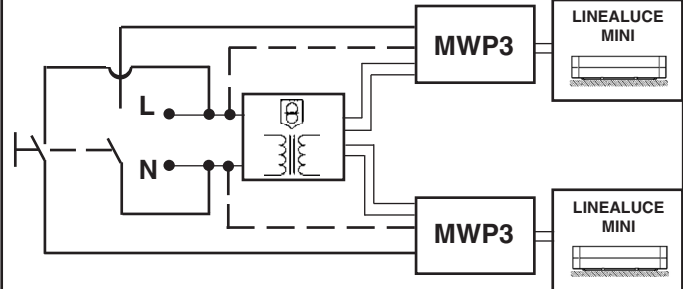

عدد المنتجات	مقطع الكابل الخارجي	أقصى طول للكابل من قابس الشحن إلى علبة التحويل	أقصى طول للكابل (1,5 م مربع) من علبة التحويل إلى المنتجات	جهد التغذية
n° prodotti no. of products Cantidad de productos	SEZIONE DEL CAVO ESTERNO EXTERNAL WIRE CROSS-SECTION SECCIÓN DEL CABLE EXTERNO	LUNGHEZZA MASSIMA DEL CAVO DALL'ALIMENTATORE ALLA SCATOLA DI DERIVAZIONE MAXIMUM LENGTH OF POWER SUPPLY CABLE TO JUNCTION BOX LONGITUD MÁXIMA DEL CABLE DE ALIMENTADOR A LA CAJA DE DERIVACIÓN	LUNGHEZZA MASSIMA DEL CAVO (1 mm ²) DALLA SCATOLA DI DERIVAZIONE AI PRODOTTI MAXIMUM LENGTH OF THE CABLE (1 mm ²) FROM THE CONNECTOR BLOCK TO THE PRODUCTS LONGITUD MÁXIMA DEL CABLE (1 mm ²) DE LA CAJA DE DERIVACIÓN A LOS PRODUCTOS	TENSIONE DI ALIMENTAZIONE POWER SUPPLY TENSION DE ALIMENTACIÓN
	(mm ²)	م Lc (m)	L1	(V)

كابل ALIMENTATORE - BALLAST - ALIMENTADOR

ART BH14 - BH15

art. MWP3 50W Vin=10-24 Vdc, 0Hz; Vout=10,5÷24Vdc

17	1,5	50	2	24
----	-----	----	---	----

ART BH20 - BH21 - BK36 - BK37 - BK80 - BK81

9	1,5	50	2	24
---	-----	----	---	----

ART BH16 - BH17

9	1,5	50	2	24
---	-----	----	---	----

ART BH22 - BH23 - BK40 - BK41 - BK84 - BK85

5	1,5	50	2	24
---	-----	----	---	----

ART BH18 - BH19

6	1,5	50	2	24
---	-----	----	---	----

ART BH24 - BH25

3	1,5	50	2	24
---	-----	----	---	----

ART BI11 - BI12

6	1,5	50	2	24
---	-----	----	---	----

ART BI13 - BI14

4	1,5	50	2	24
---	-----	----	---	----

في حالة عدم الالتزام بالأمثلة المغطاة؛ فإنه يجب أن يكون الحد الأقصى للتيار الكهربائي، الذي يستخدمه خافض الإضاءة "أوسرام" (المنفذ "إم. دبليو. بي 3") 4 أمبير، مع أخذ الفقد الذي يحدث في الكابل بعين الاعتبار.

GB I SE NON SI VOGLIONO RISPETTARE GLI ESEMPI LA MASSIMA CORRENTE UTILIZZANDO IL DIMMER OSRAM (art.MWP3) DEVE ESSERE 4A CONSIDERANDO LA PERDITA DOVUTA DAL CAVO.

E IF THE USER PREFERS NOT TO OBSERVE THE EXAMPLES, THE MAXIMUM CURRENT USING THE OSRAM DIMMER (item MWP3) MUST BE 4 A, TAKING INTO ACCOUNT THE LOSS DUE TO THE CABLE.

SINO SE DESEAN RESPETAR LOS EJEMPLOS, LA CORRIENTE MÁXIMA UTILIZANDO EL DIMMER OSRAM (art.MWP3) DEBE SER 4A, CONSIDERANDO LA DEBIDA PÉRDIDA POR EL CABLE.

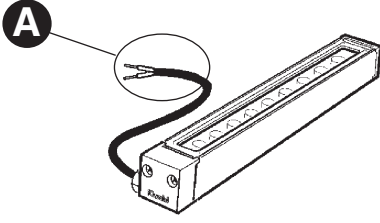

art. BH14 - BH15
BH16 - BH17
BH18 - BH19
BH20 - BH21
BH22 - BH23
BH24 - BH25
BK36 - BK37
BK40 - BK41
BK80 - BK81
BK84 - BK85
BI11 - BI12
BI13 - BI14

ملحوظة هامة: للتوصيل الكهربائي بالشبكة (المرحلة A)، استخدم المنتج BZK7 عر
أو أية أجهزة توصيل قادرة على ضمان درجة الحماية IP66.

I N.B.: Per il collegamento elettrico alla rete (Fase A), servirsi dell'art. BZK7 o di altri dispositivi di connessione che garantiscano il grado di protezione IP66.

GB N.B.: To make the connection to the mains (step A), use art. BZK7 or other connection devices which guarantee an IP66 degree of protection.

E NOTA: Para efectuar el enlace a la red eléctrica (fase A), utilizar los art. BZK7u otros dispositivos de conexión , que garantizan grado de protección IP66.

**ملاحظة: ملاحظة: أثناء تركيب نظام " LINEALUCE MINI " يجب التقيد
بحرص بالنظم السائدة المتعلقة بالشبكة الكهربائية.**

N.B.: DURANTE L'INSTALLAZIONE DEL SISTEMA " LINEALUCE MINI " RISPETTARE SCRUPolosAMENTE LE NORME IMPIANTISTICHE VIGENTI.

N.B.: WHEN INSTALLING THE SYSTEM " LINEALUCE MINI ", STRICTLY COMPLY WITH ALL REGULATIONS ON INSTALLATION IN FORCE.

N.B.: DURANTE LA INSTALACIÓN DEL SISTEMA " LINEALUCE MINI " RESPETAR ESCRUPolosAMENTE LAS NORMAS DE INSTALACIÓN VIGENTES.

تنبيه: لاستبدال الضوء LED اتصل بشركة iGuzzini . عر

I N.B.: Per la sostituzione del LED contattare l'azienda iGuzzini.

GB N.B.: For information on LED replacement please contact iGuzzini.

E NOTA: Para sustituir el LED llame a la empresa iGuzzini.

في حال تلف الكبل الخارجي المرن، يجب تغييره من قبل
المصنع أو من قبل مركز الخدمة المخوّل أو من قبل أحد
أعضاء الطاقم الممثلين والمؤهلين وذلك لتحاكي إلحاق أي
خطر.

I In caso di danneggiamento del cavo flessibile esterno, questo deve essere sostituito dal costruttore, o dal suo servizio di assistenza, o da personale qualificato equivalente, al fine di evitare pericoli.

GB Should the outer flexible cable be somehow damage, the latter should be replaced by the manufacturer, or by the corresponding service centre, or by an appropriate and qualified member of staff in order to avoid all risk of danger.

E En caso de daños el cable flexible externo debe substituirse por el fabricante, su servicio de asistencia o personal calificado equivalente para evitar peligros.



لا يمكن استعمال المنتج في حالة كسر الزجاج، وبالتالي يجب الاتصال بالمصنع لاستبداله. عر

I In caso di rottura del vetro il prodotto non può essere utilizzato, contattare il costruttore per la sua sostituzione.

GB Should the glass break, the product cannot be used and you should contact the manufacturer for its replacement.

E No utilizar el producto en caso de ruptura del vidrio y contactar el fabricante para la sustitución.

1.154.596.00
ISO6196/01

iGuzzini

I NON SOLLECITARE IL PRODOTTO A TORSIONE
GB DO NOT SUBMIT THE PRODUCT TO TWISTING
FR NE PAS SOUMETTRE LE PRODUIT À TORSION
DE LEUCHTE AUF KEINEN FALL IN LÄNGSRICHTUNG VERDREHEN!
NL BEWEEG HET PRODUCT NIET TERWIJL HET ONDERHEVIG IS AAN TORSIE
E NO FORZAR LA TORSIÓN DEL PRODUCTO
DK UDSÆ T IKKE PRODUKTET FOR VRIDNINGER
N IKKE UTSETT PRODUKTET FOR VRIDNING
S VRIDBELASTA INTE PRODUKTEN
RUS НЕ СКРУЧИВАТЬ ИЗДЕЛИЕ
CN 切勿使产品发生扭曲。

1.154.596.00
ISO6196/01

iGuzzini

I NON SOLLECITARE IL PRODOTTO A TORSIONE
GB DO NOT SUBMIT THE PRODUCT TO TWISTING
FR NE PAS SOUMETTRE LE PRODUIT À TORSION
DE LEUCHTE AUF KEINEN FALL IN LÄNGSRICHTUNG VERDREHEN!
NL BEWEEG HET PRODUCT NIET TERWIJL HET ONDERHEVIG IS AAN TORSIE
E NO FORZAR LA TORSIÓN DEL PRODUCTO
DK UDSÆ T IKKE PRODUKTET FOR VRIDNINGER
N IKKE UTSETT PRODUKTET FOR VRIDNING
S VRIDBELASTA INTE PRODUKTEN
RUS НЕ СКРУЧИВАТЬ ИЗДЕЛИЕ
CN 切勿使产品发生扭曲。

1.154.596.00
ISO6196/01

iGuzzini

I NON SOLLECITARE IL PRODOTTO A TORSIONE
GB DO NOT SUBMIT THE PRODUCT TO TWISTING
FR NE PAS SOUMETTRE LE PRODUIT À TORSION
DE LEUCHTE AUF KEINEN FALL IN LÄNGSRICHTUNG VERDREHEN!
NL BEWEEG HET PRODUCT NIET TERWIJL HET ONDERHEVIG IS AAN TORSIE
E NO FORZAR LA TORSIÓN DEL PRODUCTO
DK UDSÆ T IKKE PRODUKTET FOR VRIDNINGER
N IKKE UTSETT PRODUKTET FOR VRIDNING
S VRIDBELASTA INTE PRODUKTEN
RUS НЕ СКРУЧИВАТЬ ИЗДЕЛИЕ
CN 切勿使产品发生扭曲。

1.154.596.00
ISO6196/01

iGuzzini

I NON SOLLECITARE IL PRODOTTO A TORSIONE
GB DO NOT SUBMIT THE PRODUCT TO TWISTING
FR NE PAS SOUMETTRE LE PRODUIT À TORSION
DE LEUCHTE AUF KEINEN FALL IN LÄNGSRICHTUNG VERDREHEN!
NL BEWEEG HET PRODUCT NIET TERWIJL HET ONDERHEVIG IS AAN TORSIE
E NO FORZAR LA TORSIÓN DEL PRODUCTO
DK UDSÆ T IKKE PRODUKTET FOR VRIDNINGER
N IKKE UTSETT PRODUKTET FOR VRIDNING
S VRIDBELASTA INTE PRODUKTEN
RUS НЕ СКРУЧИВАТЬ ИЗДЕЛИЕ
CN 切勿使产品发生扭曲。

1.154.617.01 ISO7850/02			iQuzini		
ART.	fattore di potenza power factor facteur de puissance Leistungsfaktor vermogensfactor factor de potencia effektfaktor effektfaktor effektfaktor фактор мощности 功率因数	corrente assorbita absorbed current courant absorbé Stromaufnahme stroomopname corriente absorbida absorberet strøm absorbert strøm tillförd ström поглощаемая мощность 电源电流 (A)			
BI11 - BI12	1	0,463			
BI13 - BI14	1	0,655			
BH14 - BH15	1	0,175			
BH16 - BH17	1	0,304			
BH18 - BH19	1	0,459			
BH20 - BH21 - BK36 BK37 - BK80 - BK81	1	0,319			
BH22 - BH23 - BK40 BK41 - BK84 - BK85	1	0,54			
BH24 - BH25	1	0,816			

1.154.617.01 ISO7850/02			iQuzini		
ART.	fattore di potenza power factor facteur de puissance Leistungsfaktor vermogensfactor factor de potencia effektfaktor effektfaktor effektfaktor фактор мощности 功率因数	corrente assorbita absorbed current courant absorbé Stromaufnahme stroomopname corriente absorbida absorberet strøm absorbert strøm tillförd ström поглощаемая мощность 电源电流 (A)			
BI11 - BI12	1	0,463			
BI13 - BI14	1	0,655			
BH14 - BH15	1	0,175			
BH16 - BH17	1	0,304			
BH18 - BH19	1	0,459			
BH20 - BH21 - BK36 BK37 - BK80 - BK81	1	0,319			
BH22 - BH23 - BK40 BK41 - BK84 - BK85	1	0,54			
BH24 - BH25	1	0,816			

1.154.617.01 ISO7850/02			iQuzini		
ART.	fattore di potenza power factor facteur de puissance Leistungsfaktor vermogensfactor factor de potencia effektfaktor effektfaktor effektfaktor фактор мощности 功率因数	corrente assorbita absorbed current courant absorbé Stromaufnahme stroomopname corriente absorbida absorberet strøm absorbert strøm tillförd ström поглощаемая мощность 电源电流 (A)			
BI11 - BI12	1	0,463			
BI13 - BI14	1	0,655			
BH14 - BH15	1	0,175			
BH16 - BH17	1	0,304			
BH18 - BH19	1	0,459			
BH20 - BH21 - BK36 BK37 - BK80 - BK81	1	0,319			
BH22 - BH23 - BK40 BK41 - BK84 - BK85	1	0,54			
BH24 - BH25	1	0,816			

1.154.617.01 ISO7850/02			iQuzini		
ART.	fattore di potenza power factor facteur de puissance Leistungsfaktor vermogensfactor factor de potencia effektfaktor effektfaktor effektfaktor фактор мощности 功率因数	corrente assorbita absorbed current courant absorbé Stromaufnahme stroomopname corriente absorbida absorberet strøm absorbert strøm tillförd ström поглощаемая мощность 电源电流 (A)			
BI11 - BI12	1	0,463			
BI13 - BI14	1	0,655			
BH14 - BH15	1	0,175			
BH16 - BH17	1	0,304			
BH18 - BH19	1	0,459			
BH20 - BH21 - BK36 BK37 - BK80 - BK81	1	0,319			
BH22 - BH23 - BK40 BK41 - BK84 - BK85	1	0,54			
BH24 - BH25	1	0,816			

I PERIODO GIORNALIERO DI ACCENSIONE AMMESSO

GB ALLOWED DAILY OPERATION PERIOD

F DURÉE QUOTIDIENNE D'ALLUMAGE ADMISSIBLE

D ERLAUBTE TÄGLICHE EINSCHALTDAUER

NL DAGELIJKSE ONTSTEKINGSPERIODE TOEGESTAAN

E PERIODO DIARIO DE ENCENDIDO PERMITIDO

DK TILLADT TIDSRUM FOR DAGLIG TÆNDING

N TILLATT TENNINGSTID PR. DAG

S TILLÅTEN DAGLIG PERIOD SOM PRODUKTEN KAN VARA TÄND

RUS ЕЖЕДНЕВНАЯ ДОПУСТИМАЯ ПРОДОЛЖИТЕЛЬНОСТЬ РАБОТЫ

CN 允许的日常运营周期

iGuzzini

1.154.627.01
IS09175/01

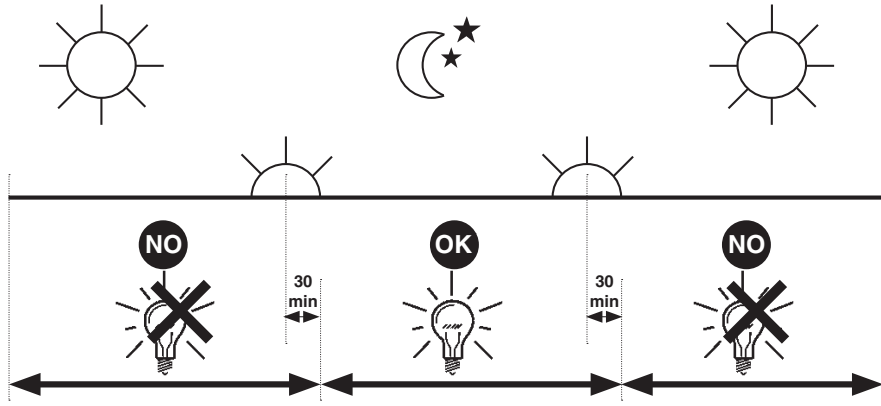

I PERIODO GIORNALIERO DI ACCENSIONE AMMESSO

GB ALLOWED DAILY OPERATION PERIOD

F DURÉE QUOTIDIENNE D'ALLUMAGE ADMISSIBLE

D ERLAUBTE TÄGLICHE EINSCHALTDAUER

NL DAGELIJKSE ONTSTEKINGSPERIODE TOEGESTAAN

E PERIODO DIARIO DE ENCENDIDO PERMITIDO

DK TILLADT TIDSRUM FOR DAGLIG TÆNDING

N TILLATT TENNINGSTID PR. DAG

S TILLÅTEN DAGLIG PERIOD SOM PRODUKTEN KAN VARA TÄND

RUS ЕЖЕДНЕВНАЯ ДОПУСТИМАЯ ПРОДОЛЖИТЕЛЬНОСТЬ РАБОТЫ

CN 允许的日常运营周期

iGuzzini

1.154.627.01
IS09175/01

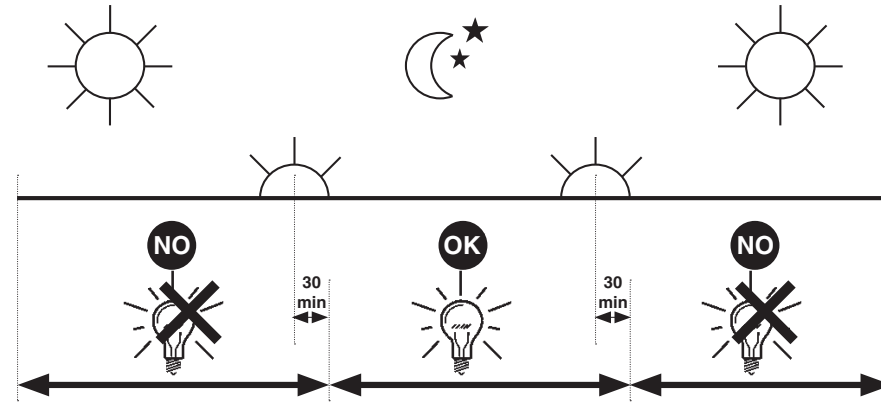

I PERIODO GIORNALIERO DI ACCENSIONE AMMESSO

GB ALLOWED DAILY OPERATION PERIOD

F DURÉE QUOTIDIENNE D'ALLUMAGE ADMISSIBLE

D ERLAUBTE TÄGLICHE EINSCHALTDAUER

NL DAGELIJKSE ONTSTEKINGSPERIODE TOEGESTAAN

E PERIODO DIARIO DE ENCENDIDO PERMITIDO

DK TILLADT TIDSRUM FOR DAGLIG TÆNDING

N TILLATT TENNINGSTID PR. DAG

S TILLÅTEN DAGLIG PERIOD SOM PRODUKTEN KAN VARA TÄND

RUS ЕЖЕДНЕВНАЯ ДОПУСТИМАЯ ПРОДОЛЖИТЕЛЬНОСТЬ РАБОТЫ

CN 允许的日常运营周期

iGuzzini

1.154.627.01
IS09175/01

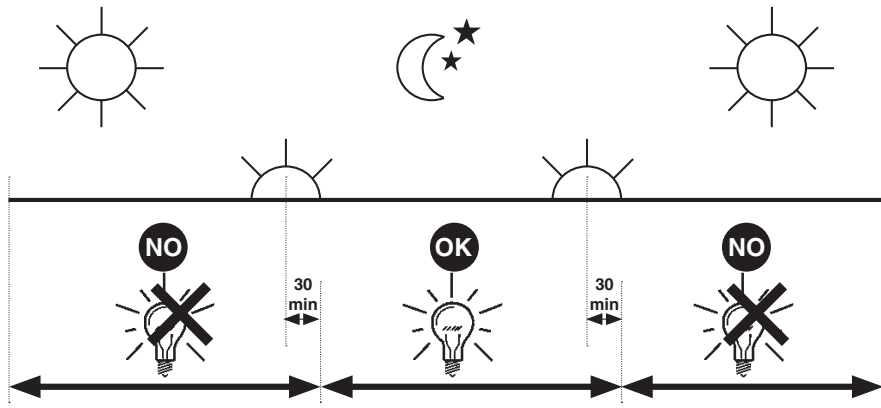

I PERIODO GIORNALIERO DI ACCENSIONE AMMESSO

GB ALLOWED DAILY OPERATION PERIOD

F DURÉE QUOTIDIENNE D'ALLUMAGE ADMISSIBLE

D ERLAUBTE TÄGLICHE EINSCHALTDAUER

NL DAGELIJKSE ONTSTEKINGSPERIODE TOEGESTAAN

E PERIODO DIARIO DE ENCENDIDO PERMITIDO

DK TILLADT TIDSRUM FOR DAGLIG TÆNDING

N TILLATT TENNINGSTID PR. DAG

S TILLÅTEN DAGLIG PERIOD SOM PRODUKTEN KAN VARA TÄND

RUS ЕЖЕДНЕВНАЯ ДОПУСТИМАЯ ПРОДОЛЖИТЕЛЬНОСТЬ РАБОТЫ

CN 允许的日常运营周期

iGuzzini

1.154.627.01
IS09175/01

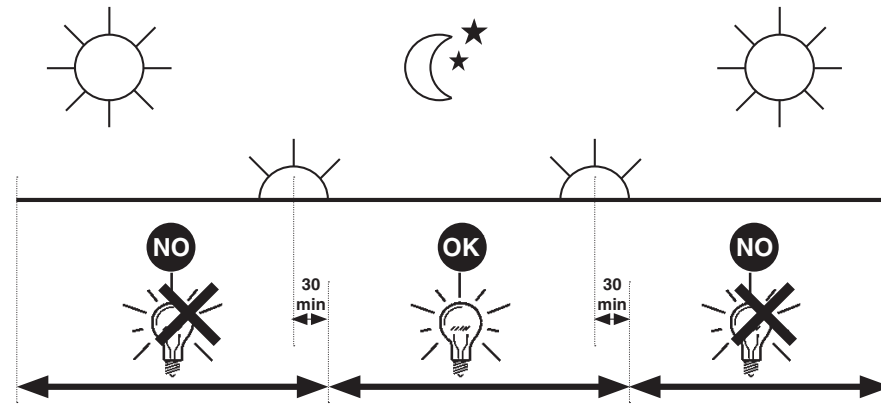

iGuzzini

2.509.386.00
ISO9176/01

الفترة الزمنية اليومية للتشغيل المسموح بها

- I PERIODO GIORNALIERO DI ACCENSIONE AMMESSO
- GB ALLOWED DAILY OPERATION PERIOD
- E PERIODO DIARIO DE ENCENDIDO PERMITIDO

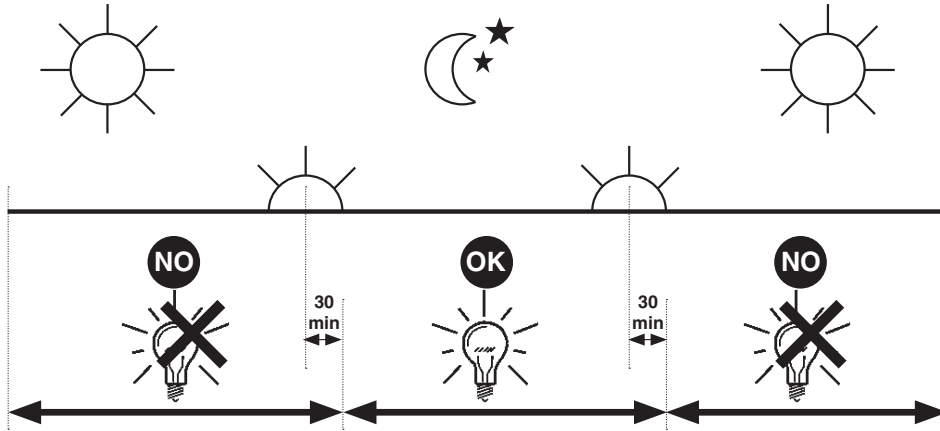

iGuzzini

2.509.386.00
ISO9176/01

الفترة الزمنية اليومية للتشغيل المسموح بها

- I PERIODO GIORNALIERO DI ACCENSIONE AMMESSO
- GB ALLOWED DAILY OPERATION PERIOD
- E PERIODO DIARIO DE ENCENDIDO PERMITIDO

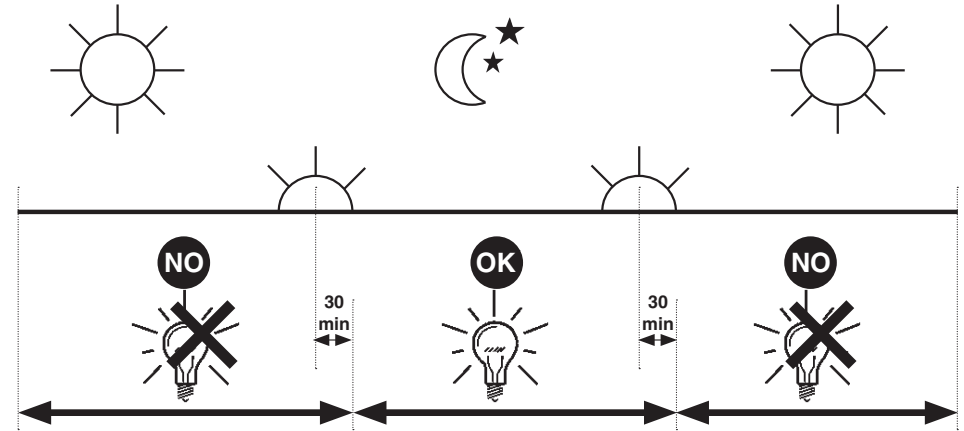

iGuzzini

2.509.386.00
ISO9176/01

الفترة الزمنية اليومية للتشغيل المسموح بها

- I PERIODO GIORNALIERO DI ACCENSIONE AMMESSO
- GB ALLOWED DAILY OPERATION PERIOD
- E PERIODO DIARIO DE ENCENDIDO PERMITIDO

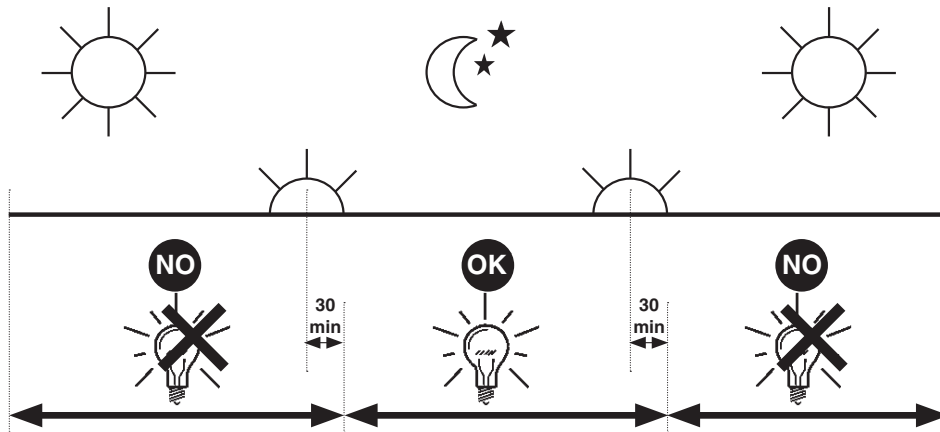

iGuzzini

2.509.386.00
ISO9176/01

الفترة الزمنية اليومية للتشغيل المسموح بها

- I PERIODO GIORNALIERO DI ACCENSIONE AMMESSO
- GB ALLOWED DAILY OPERATION PERIOD
- E PERIODO DIARIO DE ENCENDIDO PERMITIDO

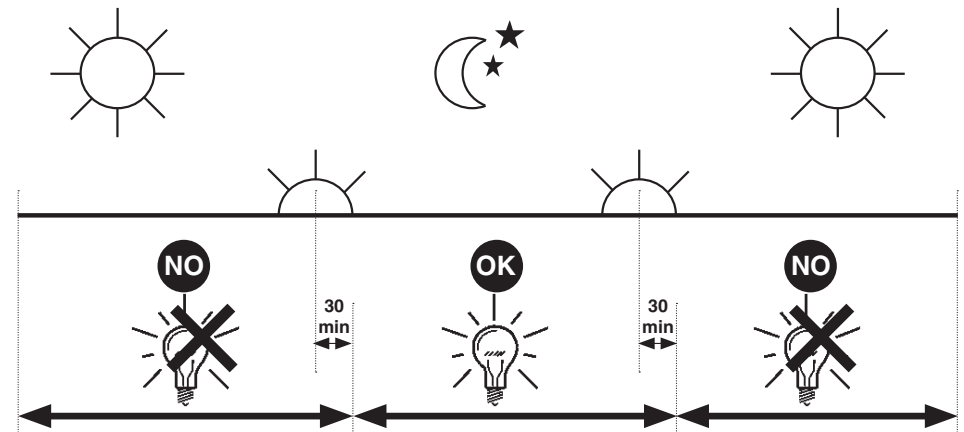

عر

لا تعرض المنتج للالتواء

- I NON SOLLECITARE IL PRODOTTO A TORSIONE
- GB DO NOT SUBMIT THE PRODUCT TO TWISTING
- E NO FORZAR LA TORSIÓN DEL PRODUCTO

2.509.257.00
IS06811/00

عر

لا تعرض المنتج للالتواء

- I NON SOLLECITARE IL PRODOTTO A TORSIONE
- GB DO NOT SUBMIT THE PRODUCT TO TWISTING
- E NO FORZAR LA TORSIÓN DEL PRODUCTO

2.509.257.00
IS06811/00

عر

لا تعرض المنتج للالتواء

- I NON SOLLECITARE IL PRODOTTO A TORSIONE
- GB DO NOT SUBMIT THE PRODUCT TO TWISTING
- E NO FORZAR LA TORSIÓN DEL PRODUCTO

2.509.257.00
IS06811/00

عر

لا تعرض المنتج للالتواء

- I NON SOLLECITARE IL PRODOTTO A TORSIONE
- GB DO NOT SUBMIT THE PRODUCT TO TWISTING
- E NO FORZAR LA TORSIÓN DEL PRODUCTO

2.509.257.00
IS06811/00

عر

لا تعرض المنتج للالتواء

- I NON SOLLECITARE IL PRODOTTO A TORSIONE
- GB DO NOT SUBMIT THE PRODUCT TO TWISTING
- E NO FORZAR LA TORSIÓN DEL PRODUCTO

عر

منتج للالتواء

- I NON SOLLECITARE IL PRODOTTO
- GB DO NOT SUBMIT THE PRODUCT
- E NO FORZAR LA TORSIÓN DEL PR

2.509.257.00
IS06811/00

عر

منتج للالتواء

- I NON SOLLECITARE IL PRODOTTO
- GB DO NOT SUBMIT THE PRODUCT
- E NO FORZAR LA TORSIÓN DEL PR

2.509.257.00
IS06811/00

عر

منتج للالتواء

- I NON SOLLECITARE IL PRODOTTO
- GB DO NOT SUBMIT THE PRODUCT
- E NO FORZAR LA TORSIÓN DEL PR

2.509.257.00
IS06811/00

عر

منتج للالتواء

- I NON SOLLECITARE IL PRODOTTO
- GB DO NOT SUBMIT THE PRODUCT
- E NO FORZAR LA TORSIÓN DEL PR

2.509.257.00
IS06811/00

عر

منتج للالتواء

- I NON SOLLECITARE IL PRODOTTO
- GB DO NOT SUBMIT THE PRODUCT
- E NO FORZAR LA TORSIÓN DEL PR

- I Istruzioni per le operazioni di servizio per l'apparecchio di illuminazione**
GB Instructions on luminaire service operations
F Instructions pour les opérations de service du luminaire
D Wartungsanleitung für die Leuchte
NL Instructies voor de onderhoudsoperaties op de verlichtingsarmatuur
E Instrucciones para las operaciones de servicio del aparato de alumbrado
DK Anvisninger i serviceindgreb på belysningsarmatur
N Anvisninger for betjening av lysapparatet
S Instruktioner för användning av belysningsanordningen
RUS Инструкции по эксплуатации осветительного прибора
CN 照明装置检修操作说明

Sostituire la lampada parzialmente esausta
 Replace the partly exhausted lamp
 Remplacer la lampe partiellement épuisée
 Die teilweise erschöpfte Lampe austauschen
 Vervang de gedeeltelijk lege lamp
 Sustituir la lámpara parzialmente agotada
 Udskift den delvist udtjente pære
 Skifte ut den delvis utbrente lyspæren
 Byt ut den delvis förbrukade lampan
 Замена частично отработанной лампочки
 更换部分老化的灯泡



Spegnimento
 Switch it off
 Extinction
 Ausschaltung
 Uitschakeling
 Apagado
 Slukning
 Slukking
 Släckning
 Выключение
 关灯

Interrompere l'alimentazione dell'apparecchio
 Cut the power supply to the luminaire
 Couper l'alimentation du luminaire
 Stromversorgung der Leuchte unterbrechen
 Onderbreek de voeding van het apparaat
 Interrumpir la alimentación del aparato
 Afbryd armaturets strømforsyning
 Avbryte strømtilførselen til apparatet
 Koppla från anordningens strömförsörjning
 Отключить электропитание прибора
 中断装置供电



Aprire l'apparecchio
 Open the fixture
 Ouvrir le luminaire
 Das Gerät öffnen
 Open het apparaat
 Abrir el aparato
 Åbn armaturet
 Åpne apparatet
 Öppna anordningen
 Раскрыть прибор
 打开装置



Rimuovere la lampada esausta
 Remove the exhausted lamp
 Retirer la lampe épuisée
 Die alte Lampe entnehmen
 Verwijder de lege lamp
 Quitar la lámpara agotada
 Tag den udtjente pære ud
 Fjerne den utbrente lyspæren
 Ta bort den förbrukade lampan
 Вынуть старую лампочку
 取出老化的灯泡

Portarla in un centro di riciclaggio
 Carry it to a recycling centre
 La porter dans une déchetterie pour son recyclage
 Ordnungsgemäß entsorgen
 Breng de lamp naar een recyclingcentrum
 Llevarla a un centro de reciclaje
 Aflever den på en genbrugsstation
 Lever den til en miljøstasjon
 Lämna in den till en återvinningsanläggning
 Сдать ее в пункт приема утильсырья
 将其送往回收中心



Inserire la nuova lampada
 Introduce the new lamp
 Installer la lampe neuve
 Die neue Lampe einsetzen
 Doe de nieuwe lamp op zijn plek
 Montar la nueva lámpara
 Sæt den nye pære i
 Sette i den nye pæren
 Sätt i den nya lampan
 Вставить новую лампочку
 装入新灯泡

Inserire la nuova lampada nel portalampada
 Fit the new lamp into the socket
 Installer la nouvelle lampe dans le support de lampe
 Die neue Lampe in den Sockel einsetzen
 Doe de nieuwe lamp in de lamphouder
 Montar la nueva lámpara en el portalámpara
 Sæt den nye pære i fatningen
 Sette den nye pæren inn i lampeholderen
 Sätt i den nya lampan i lamphållaren
 Вставить новую лампочку в патрон
 将新灯泡插入灯泡架中



Riposizionare ottica
 Re-place the optic
 Remettre l'optique à sa place
 Die Optik wieder einsetzen
 Doe de optiek weer op zijn plaats
 Volver a montar la óptica
 Sæt den optiske enhed på plads
 Innstille linsen
 Flytta om optiken
 Отрегулировать линзы
 重新定位光头



Effettuare prova di funzionamento
 Perform operative test
 Procéder à un essai de fonctionnement
 Eine Funktionsprüfung durchführen
 Controleer de correcte werking
 Hacer una prueba de funcionamiento
 Afprøv funktionen
 Prøve om den fungerer
 Utför funktionstest
 Выполнить проверку исправности работы
 执行功能测试



I Istruzioni per la pulizia dell'apparecchio di illuminazione
GB Instructions on luminaire cleaning operations
F Instructions pour le nettoyage du luminaire
D Anweisungen zur Reinigung der Leuchte
NL Instructies voor de reiniging van de verlichtingsarmatuur
E Instrucciones para limpiar el aparato de alumbrado
DK Anvisninger i rengøring af belysningsarmaturet
N Anvisninger for rengjøring av lysapparatet
S Instruktioner för rengöring av belysningsanordningen
RUS Инструкции по чистке осветительного прибора
CN 照明装置清洁说明

Pulire l'apparecchio
Clean the fixture
Nettoyer le luminaire
Das Gerät reinigen
Reinig het apparaat
Limpiar el aparato
Rengør armaturet
Rengjøre apparatet
Rengör anordningen
Чистка прибора
清洁装置



Spegnimento
Switch it off
Extinction
Ausschaltung
Uitschakeling
Apagado
Slukning
Slukking
Släckning
Выключение
关灯

Interrompere l'alimentazione dell'apparecchio
Cut the power supply to the luminaire
Couper l'alimentation du luminaire
Stromversorgung der Leuchte unterbrechen
Onderbreek de voeding van het apparaat
Interrumpir la alimentación del aparato
Afbryd armaturets strømforstyrning
Avbryt strømtilførselen til apparatet
Koppla från anordningens strömförsörjning
Отключить электропитание прибора
中断装置供电



Spolverare l'ottica esterna
Remove dust from the external optic
Dépoussiérer l'optique extérieure
Die externe Optik abstauben
Stof de externe optiek af
Quitar el polvo de la óptica exterior
Tør støvet af den udvendige optiske enhed
Fjerne støv fra den eksterne lysenheden
Damma av den yttre optiken
Вытереть пыль с внешней стороны линз
为外侧光头掸尘



Lavare l'ottica esterna
Wash the external optic
Laver l'optique extérieure
Die externe Optik waschen
Was de externe optiek
Lavar la óptica exterior
Vask den udvendige optiske enhed
Vaske den eksterne lysenheden
Rengör den yttre optiken
Вымыть линзы с внешней стороны
清洁外光头



Rimuovere l'ottica
Remove the optic
Retirer l'optique
Die Optik abnehmen
Verwijder de optiek
Quitar la óptica
Tag den optiske enhed af
Fjerne lysenheden
Ta bort optiken
Снять линзы
取下光头



Pulire la parte interna dell'apparecchio di illuminazione
Clean the inside of the fixture
Nettoyer l'intérieur du luminaire
Die Innenseite der Leuchte reinigen
Reinig de binnenzijde van de verlichtingsarmatuur
Limpiar el interior del aparato de alumbrado
Rengør belysningsarmaturets indvendige dele
Rengjøre lysapparatet innvendig
Rengör belysningsanordningen invändigt
Протереть осветительный прибор изнутри
清洁照明装置内部



Riposizionare ottica
Re-place the optic
Remettre l'optique à sa place
Die Optik wieder einsetzen
Doe de optiek weer op zijn plaats
Volver a montar la óptica
Sæt den optiske enhed på plads
Innstille linsen
Flytta om optiken
Отрегулировать линзы
重新定位光头



Effettuare prova di funzionamento
Perform operative test
Procéder à un essai de fonctionnement
Eine Funktionsprüfung durchführen
Controleer de correcte werking
Hacer una prueba de funcionamiento
Afprov funktionen
Prøve om den fungerer
Utför funktionstest
Выполнить проверку исправности работы
执行功能测试

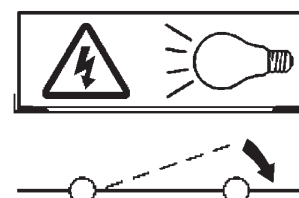

- I** Istruzioni per il fine vita e lo smaltimento dei componenti
GB Instructions on end-of-life and component disposal
F Instructions pour la gestion des composants en fin de vie et leur mise au rebut
D Anweisungen zur Entsorgung der Leuchtenkomponenten
NL Instructies voor het verwijderen van de armatuur en het recyclen van de onderdelen
E Instrucciones para el final de vida y la eliminación los componentes
DK Anvisninger i udtjent armatur og bortskaffelse af komponenter
N Anvisninger for endt levetid og avfallsbehandling av delene
S Instruktioner vid bortskaffning och kassering av komponenter
RUS Инструкции по утилизации прибора и его комплектующих по окончании его срока службы
CN 寿命期结束与零件废弃处置说明

<p>Spegnimento Switch it off Extinction Ausschaltung Uitschakeling Apagado Slukning Slukking Släckning Выключение 关灯</p> <p>Interrompere l'alimentazione dell'apparecchio Cut the power supply to the luminaire Couper l'alimentation du luminaire Stromversorgung der Leuchte unterbrechen Onderbreek de voeding van het apparaat Interrompirla alimentación del aparato Afbryd armaturets strømforsyning Avbryt strømtilførselen til apparatet Koppla från anordningens strömförsörjning Отключить электропитание прибора 中断装置供电</p> 	<p>Rimuovere la/e lampada/e per la dismissione Remove the lamp(s) for decommissioning Retirer la(les) lampe(s) pour sa(leur) mise au rebut Die Lampe/n ordnungsgemäß entsorgen Verwijder de lamp(en) voor het recyclen Quitar la(s) lámpara(s) para el desecho Tag pæren/pærerne ud til bortskaffelse Fjerne lampen/-e som skal kastes Ta bort lampan/-orna för bortskaffningen Вынуть лампочку/и для утилизации прибора 取出需要丢弃的灯泡</p> 	<p>Rimuovere la batteria per la dismissione Remove the battery for decommissioning Retirer la batterie pour sa mise au rebut Die Batterie ordnungsgemäß entsorgen Verwijder de batterij voor het recyclen Quitar la batería para el desecho Tag batteriet ud til bortskaffelse Fjerne batteriet som skal kastes Ta bort batteriet för bortskaffningen Вынуть батарейку для утилизации прибора 取出需要丢弃的电池</p> 	<p>Rimuovere l'apparecchio per la dismissione Remove the fixture for decommissioning Enlever le luminaire pour sa mise au rebut Das Gerät ordnungsgemäß entsorgen Verwijder het apparaat voor het recyclen Quitar el aparato para el desecho Tag armaturet ud til bortskaffelse Fjerne apparatet som skal kastes Ta bort anordningen för bortskaffningen Снять прибор для утилизации 取出需要丢弃的装置</p> 
---	--	--	--

<p>Inviare i materiali ad un centro di raccolta RAEE Send the materials to a WEEE collection centre Envoyer les matériaux dans une déchetterie DEEE Die Materialien in einem WEEE-Zentrum entsorgen Zend de materialen naar een recyclingscentrum voor de AEEA Enviar los materiales a un centro de recogida RAEE Afløver materialerne på et indsamlingscenter for elektronisk udstyr Sende materialene til en miljøstasjon for resirkulering av EE-avfall Skicka materialet till en RAEE uppsamlingscentral Сдать материалы в пункт приема утильсырья 将材料送往电气和电子垃圾回收中心</p> 			
--	--	--	--