

LINEALUCE MINI 37 MONOCHROME - RGB (DMX - RDM)

ATTENZIONE:

LA SICUREZZA DELL'APPARECCHIO E' GARANTITA SOLO CON L'USO APPROPRIATO DELLE SEGUENTI ISTRUZIONI; PERTANTO E' NECESSARIO CONSERVARLE.

WARNING:

THE SAFETY OF THIS FIXTURE IS GUARANTEED ONLY IF YOU COMPLY WITH THESE INSTRUCTIONS; REMEMBER TO CONSERVE IN A SAFE PLACE.

ATTENTION:

LA SECURITE DE L'APPAREIL N'EST GARANTIE QU'EN CAS D'UTILISATION CORRECTE DES INSTRUCTIONS SUIVANTES; IL FAUT PAR CONSEQUENT LES CONSERVER.

ACHTUNG:

DIE SICHERHEIT DES GERÄTES WIRD NUR DURCH SACHGEMÄSSE BEFOLGUNG NACHSTEHENDER ANWEISUNGEN GEWÄHRLEISTET; IHRE AUFBEWAHRUNG IST DESHALB SEHR WICHTIG.

OPGELET:

DE VEILIGHEID VAN DI ATOESTEL IS SLECHTS DAN GEGARANDEERD ALS INDIEN DE VOLGENDE INSTRUCTIES STRIKT WORDEN TOEGEPAST. DAAROM MOET MEN ZE OOK BEWAAREN.

ATENCION:

LA SEGURIDAD DEL APARATO SE GARANTIZA SOLO CUMPLIENDO CUIDADOSAMENTE LAS SIGUIENTES INSTRUCCIONES; POR ELLO, ES NECESARIO CONSERVARLAS.

BEMÆRK:

SIKKERHEDEN VED BRUG AF ARMATURET KAN KUN GARANTERES, HVIS DISSE ANVISNINGER FØLGES; SØRG DERFOR FOR AT GEMME DEM.

ADVARSEL:

SIKKERHETEN TIL DETTE APPARATET GARANTERES KUN HVIS DU OVERHOLDER DISSE INSTRUKSJONENE; HUSK Å OPPBEVARE DEM PÅ ET TRYGT STED.

OBSERVERA!

UTRUSTNINGENS SÄKERHET KAN ENDAST GARANTERAS OM DESSA ANVISNINGAR RESPEKTERAS I DETALJ. SPARA DÄRFÖR DESSA ANVISNINGAR FÖR FRAMTIDA KONSULTATION.

ВНИМАНИЕ:

МЫ ГАРАНТИРУЕМ БЕЗОПАСНУЮ ЭКСПЛУАТАЦИЮ ИЗДЕЛИЯ ТОЛЬКО ПРИ СОБЛЮДЕНИИ СЛЕДУЮЩИХ ИНСТРУКЦИЙ; С ЭТОЙ ЦЕЛЬЮ НЕОБХОДИМО СОХРАНИТЬ ДАННУЮ БРОШЮРУ.

警告

为确保该装置安全，请遵守操作指示；并于安全场所放置。

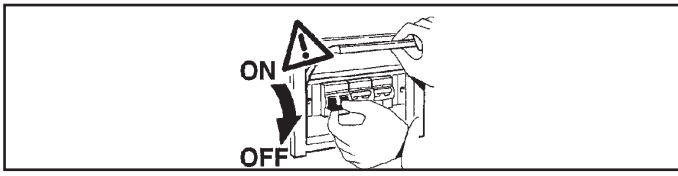
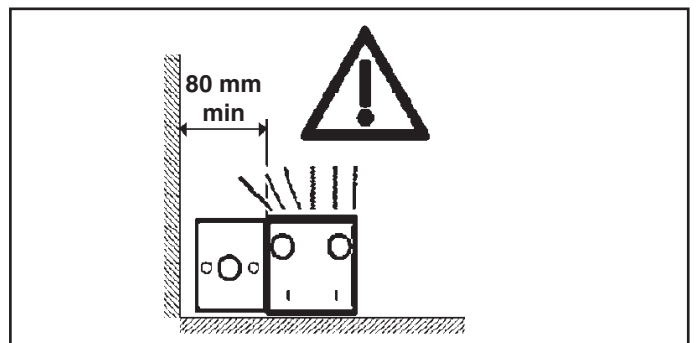
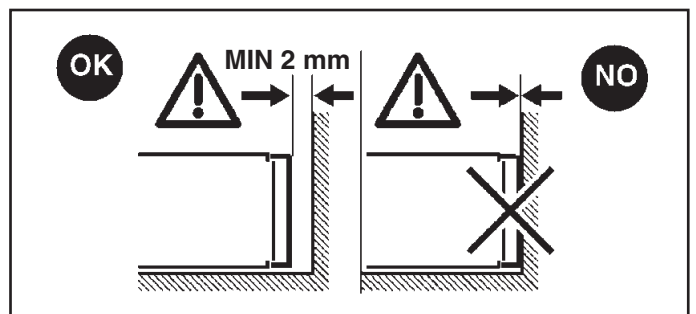
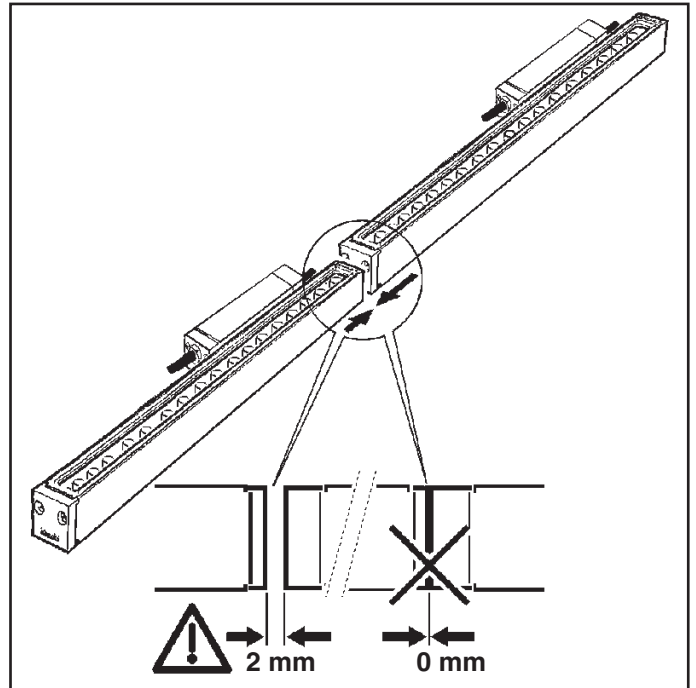
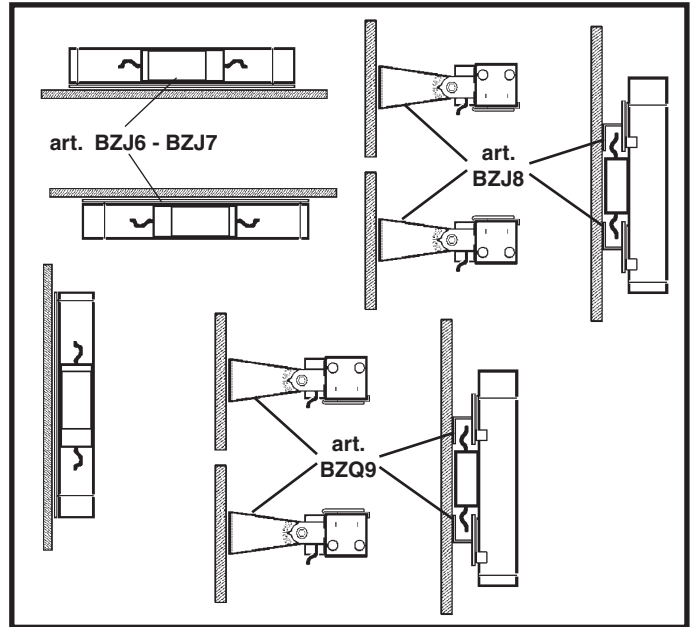

L	ART.	L (mm)
	L	BL36 - BL37 - BM73 - BM74 BM81 - BM82 - BJ20
BL38 - BL39 - BM75 - BM76 BM83 - BM84		1040
	BL40 - BL41	1570
	BJ21	1004
	BJ22	1496

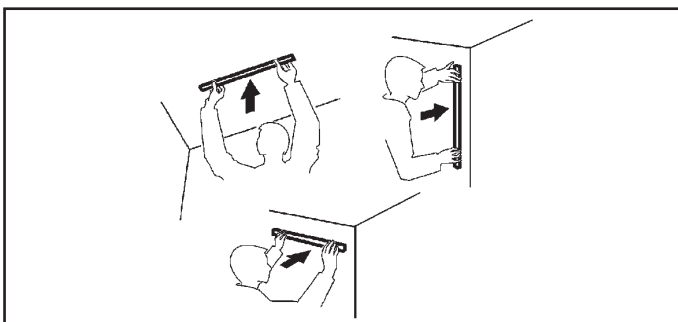

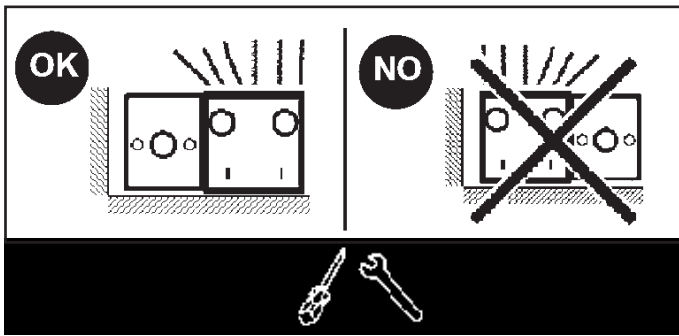

INSTALLAZIONE DEI SUPPORTI MECCANICI
 INSTALLATION OF THE MECHANICAL SUPPORTS
 INSTALLATION DES SUPPORTS MECANIQUEUS
 BEFESTIGUNG DER HALTEVORRICHTUNGEN
 HET INSTALLEREN VAN DE MECHANISCHE STEUNEN
 INSTALACIÓN DE LOS SOPORTES MECÁNICOS
 INSTALLATION AF MEKANISKE HOLDERE
 INSTALLASJON AV DE MEKANISKE STÖTTENE
 INSTALLATION AV METALLHÅLLARE
 МОНТАЖ МЕХАНИЧЕСКИХ КРЕПЛЕНИЙ
 机械支架的安装

TABELLA INTERASSI DI FORATURA
 TABLE OF CENTRE TO CENTRE DISTANCES OF HOLING
 TABLEAU DES ESPACEMENT DE PERÇAGE
 TABELLE DER BOHR - MITTENABSTÄNDE
 TABEL VAN DE AFSTAND TUSSEN DE ASSEN VAN DE GATEN
 TABLA INTER - EJES DE PERFORACION
 TABEL OVER HULAFSTAND
 TABELL OVER AVSTANDER PÅ HULLING SENTER TIL SENTER
 TABELL FÖR HÅLDELNING
 ТАБЛИЦА ШАГОВ ОТВЕРСТИЙ
 面板孔的中心距离

ART.	BZJ8 BZQ9	BZJ6	BZJ7
	K (mm)		
BL36 - BL37 - BM73 - BM74 MB81 - MB82 - BJ20	318		
BJ21	810	265	/
BL38 - BL39 - BM75 - BM76 BM83 - BM84	846		
BJ22	1299	/	600
BL40 - BL41	1375		

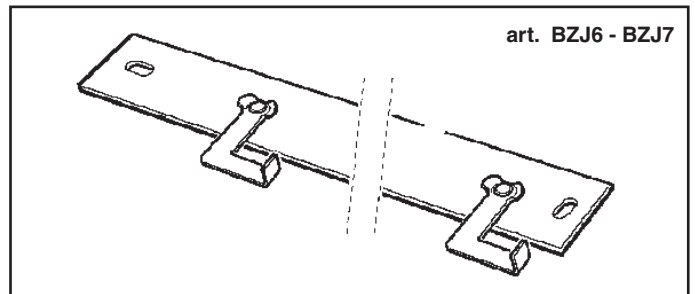
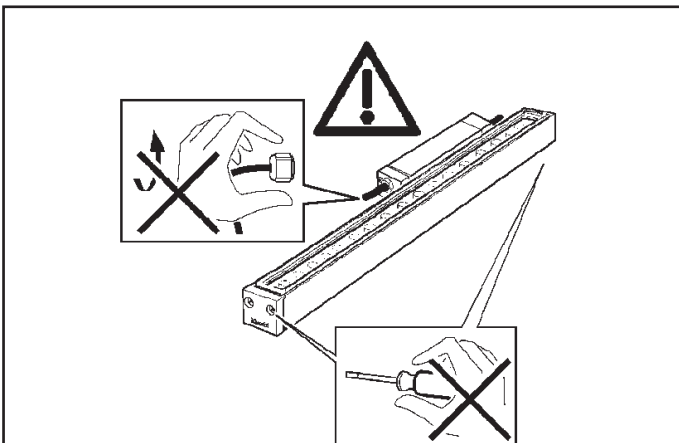
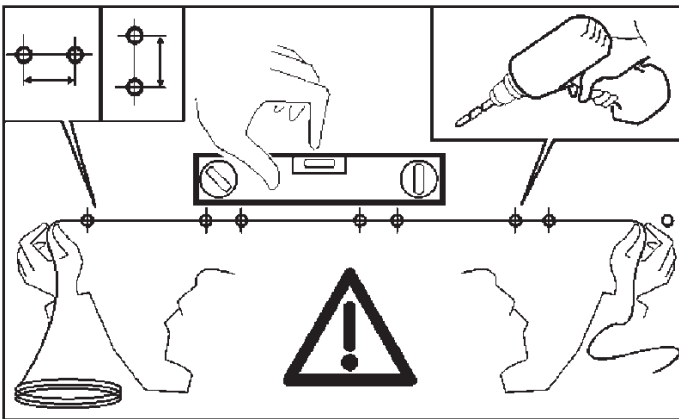

art. BZJ6 - BZJ7

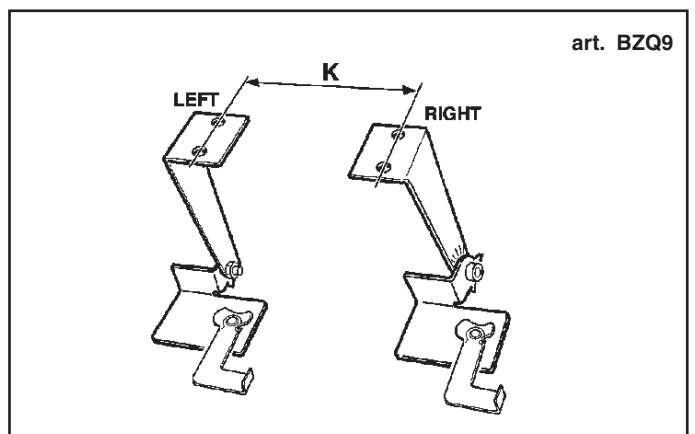
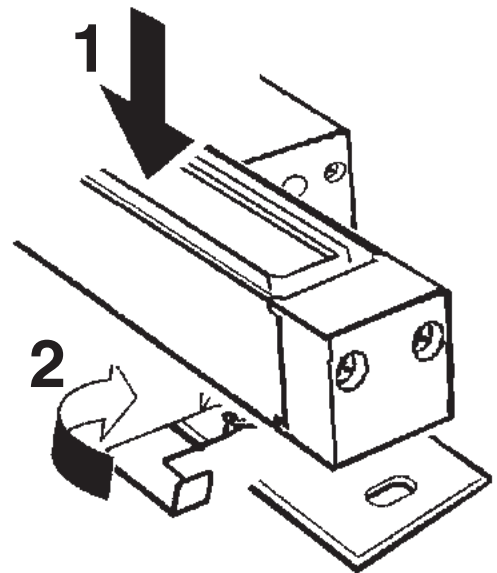
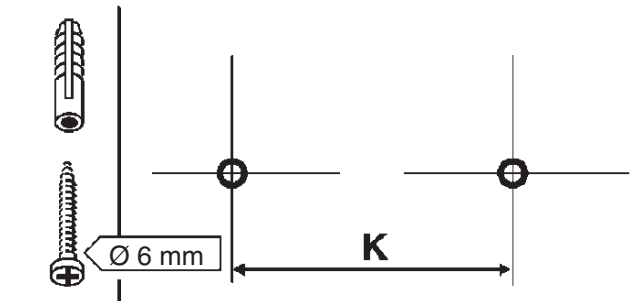

art. BZQ9

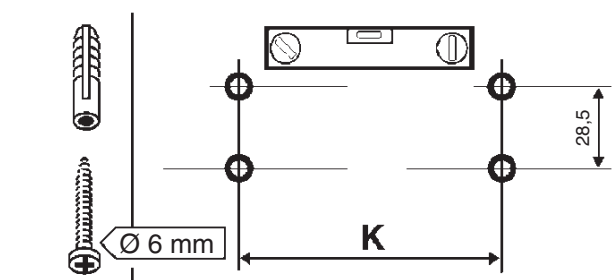

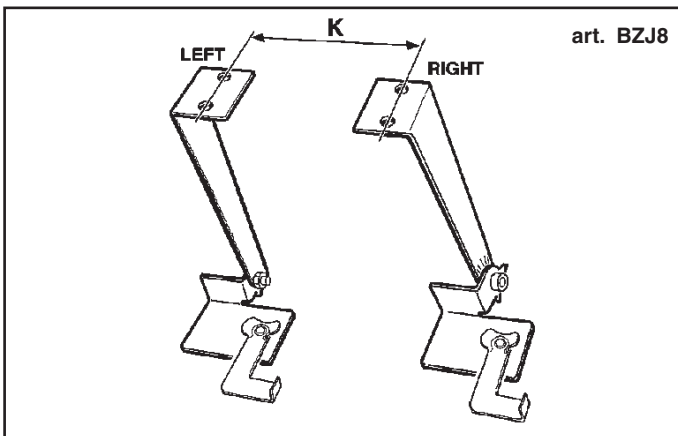
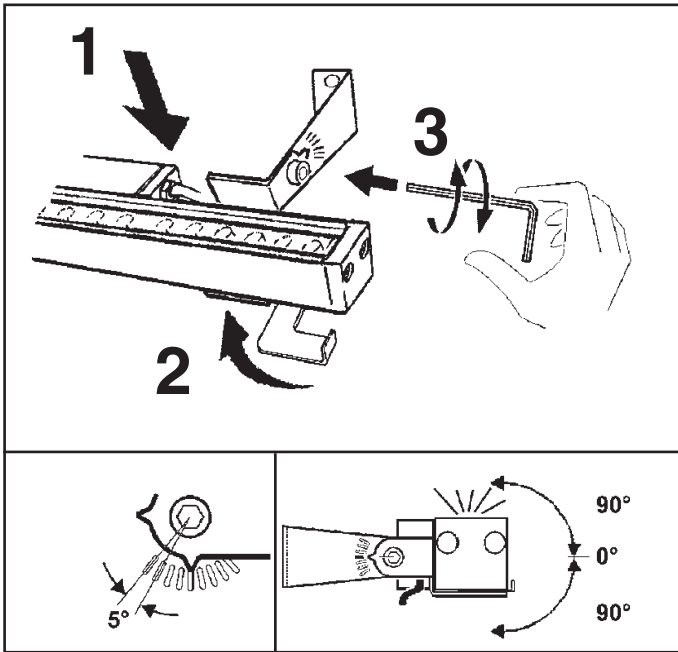

art. BZJ8

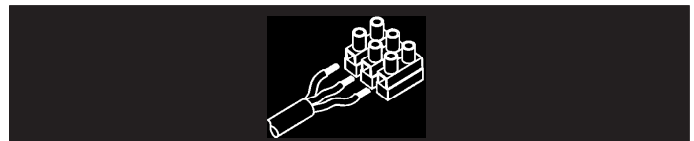
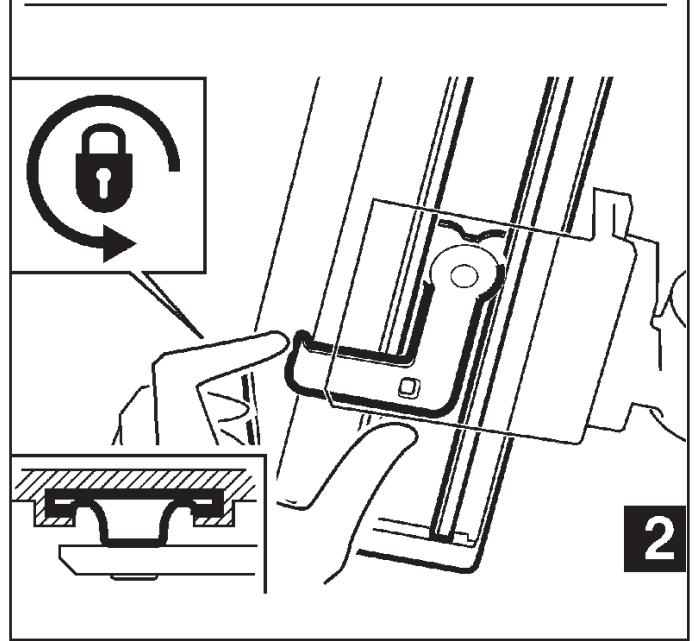
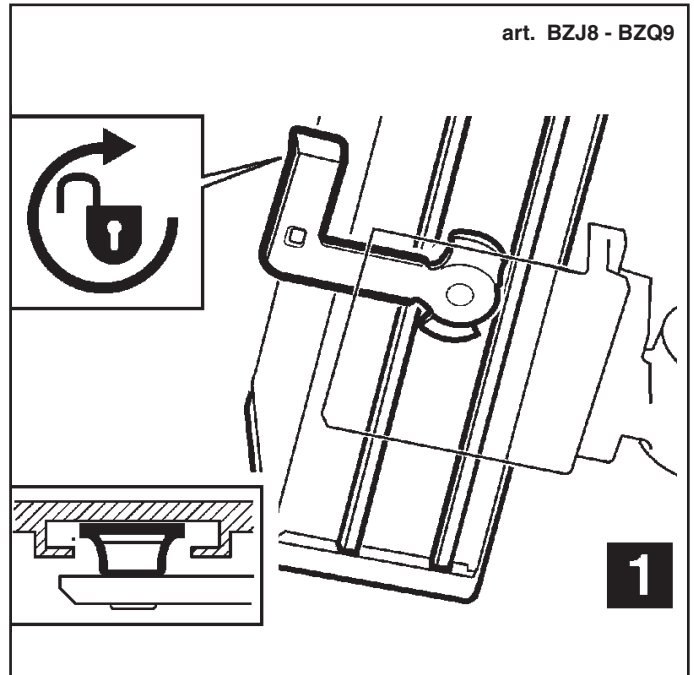
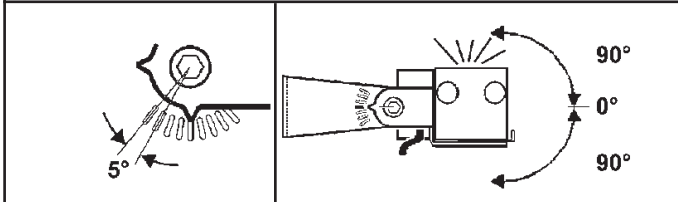
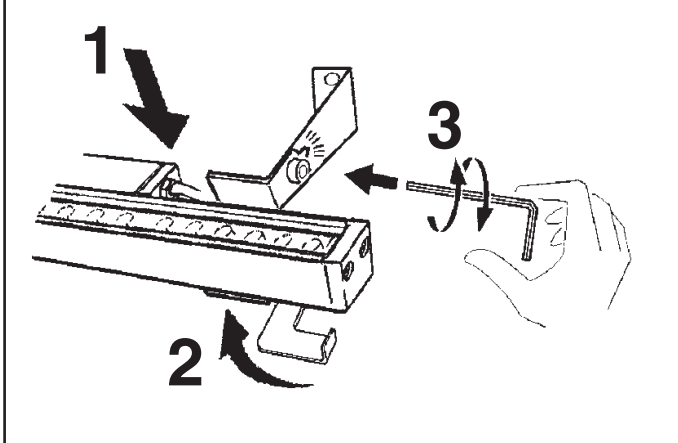
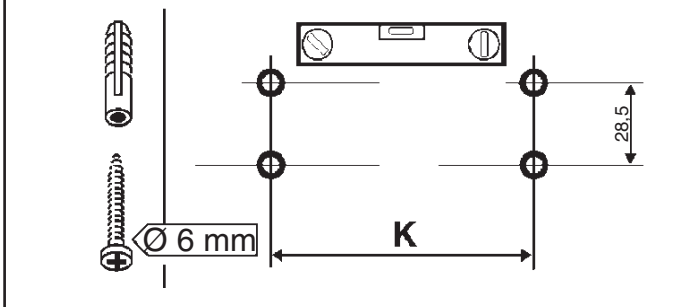

RGB	MIN 40Vdc MAX 52Vdc	48Vdc
MONOCROMATICO	MIN 34Vdc MAX 52Vdc	

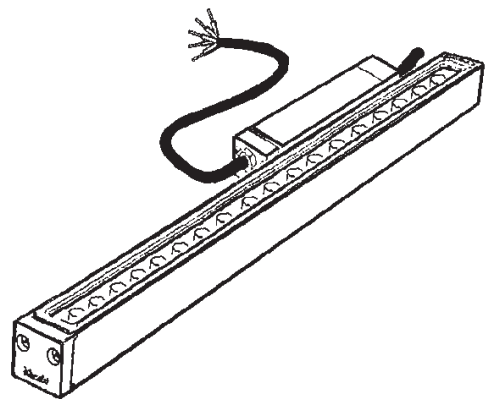

art. BZS6

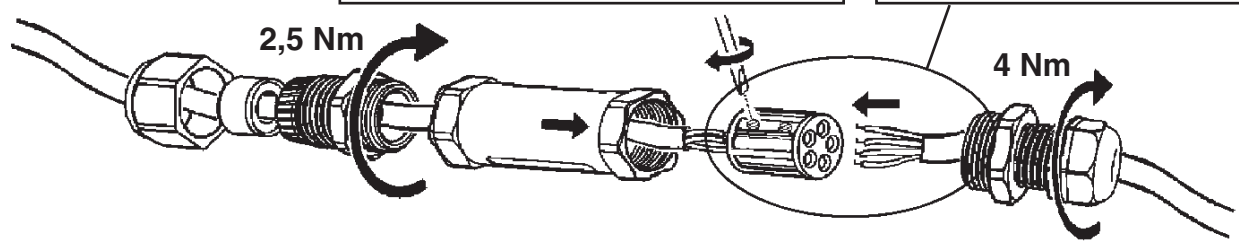
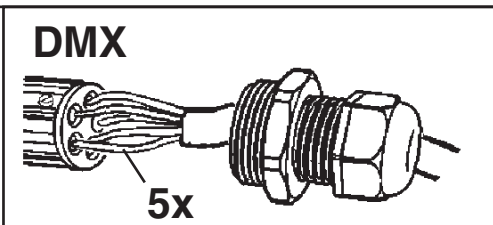
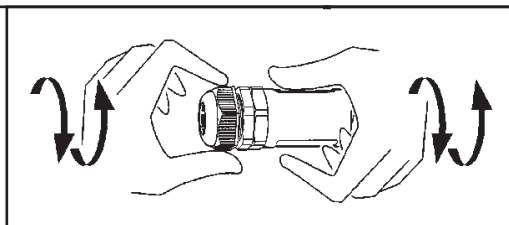

DMX

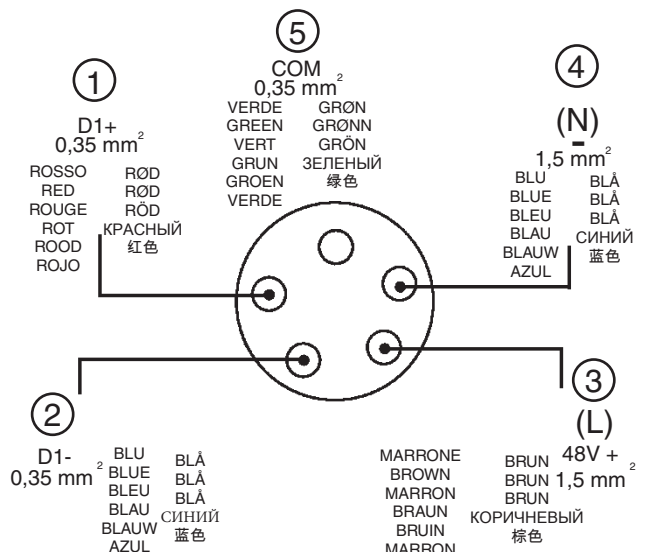

S Se till att anslutningens polaritet är korrekt innan anordningen strömförsörjs. En felaktig anslutning kan leda till att produkten fungerar på ett felaktigt sätt.
 РУS Перед запитыванием системы проверить правильность подсоединений полюсов. Неправильное подсоединение может привести к неисправной работе приборов.
 CN 为系统供电前, 请确保两极连接正确。不正确的连接可能会导致产品发生故障。

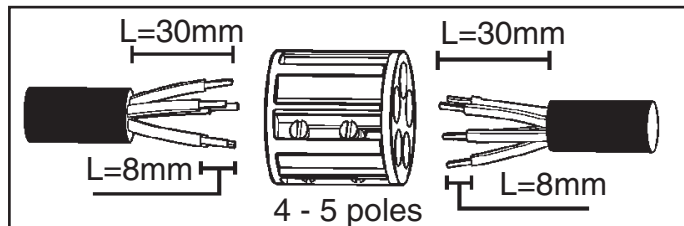
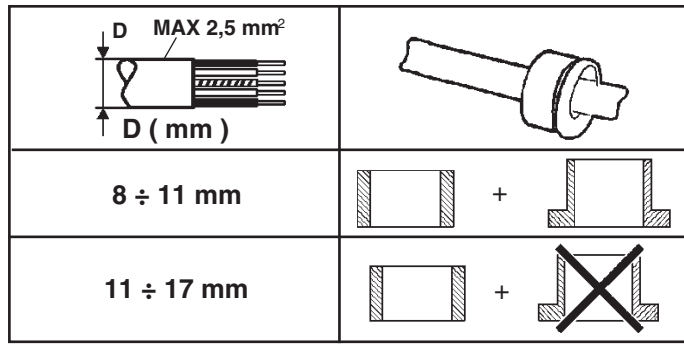

Product version	ADDRESSES n°	ADDRESSES			
		1	2	3	4
Monochrome	1	White			
WNC	3	Warm	Neutral	Cool	
RGB	3	Red	Green	Blue	
WRGB	4	Red	Green	Blue	White
WRGBW	4	Red	Green	Blue	White



I Prima di alimentare l'impianto assicurarsi del corretto collegamento delle polarità. Un errato collegamento può comportare il malfunzionamento dei prodotti.
 GB Before powering the system, make sure polarities were properly connected. Incorrect connection may cause the product to malfunction.
 F Avant de mettre l'installation sous tension, assurez-vous que la polarité de connexion est respectée. Une erreur de connexion peut entraîner le mauvais fonctionnement du produit.
 D Bevor die Anlage mit Strom versorgt wird ist sicherzustellen, dass die Pole richtig angeschlossen wurden. Ein falscher Anschluss kann die Fehlfunktion der Produkte zur Folge haben.
 NL Voordat u de installatie onder stroom zet dient u zich ervan te verzekeren dat de polariteiten correct zijn aangesloten. Een onjuiste aansluiting kan een verkeerde werking van de producten teweegbrengen.
 E Antes de alimentar la instalación compruebe que la conexión de las polaridades sea correcta. Una conexión incorrecta puede ocasionar el malfuncionamiento de los productos.
 DK Inden der sættes strøm på anlægget, skal man sikre sig, at polerne er forbundet korrekt. En forkert tilslutning kan medføre fejlfunktion på produkterne.
 N Kontrollere at du har koblet med korrekt polaritet, før du kobler strømmen til anlegget. Feil tilkobling kan føre til at produktene ikke fungerer korrekt.

I N.B.: Per chiudere la linea DMX inserire sull'ultimo modulo l'art. BZQ7.
 GB N.B.: To close the DMX line, add item BZQ7 onto the last module.
 F N.B.: Pour fermer la ligne DMX, saisir l'article BZQ7 dans le dernier module.
 D N.B.: Zum Schließen der DMX-Linie am letzten Modul den Artikel BZQ7 einsetzen.
 NL N.B.: Teneinde de DMX lijn af te sluiten, dient u op de laatste module het artikel BZQ7 in te voeren.
 E Nota: Para cerrar la línea DMX introducir en el último módulo el art. BZQ7.
 DK N.B.: For at lukke DMX-linjen skal man installere art. BZQ7 på sidste modul.
 N NB! For å lukke DMX-linjen må du sette art. BZQ7 på den siste modulen.
 S OBS! För att avsluta DMX-linjen, sätt in art. BZQ7 på sista modulen.
 РУS ПРИМЕЧАНИЕ: Для замыкания линии DMX установите на последний модуль арт. BZQ7.
 CN 注意: 如要关闭 DMX 线, 请将部件 BZQ7 加入到最后一个模块中。

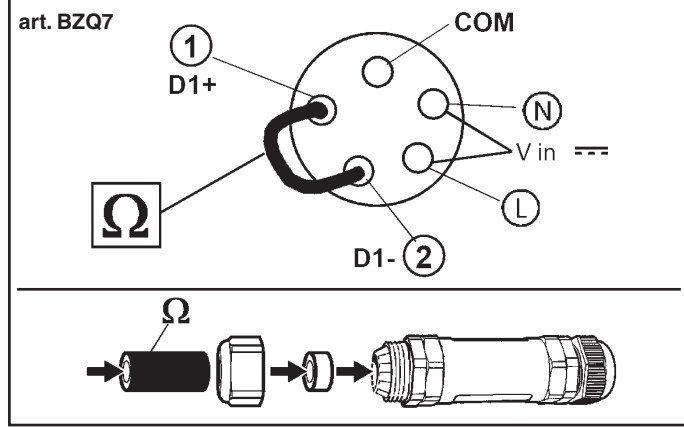

examples

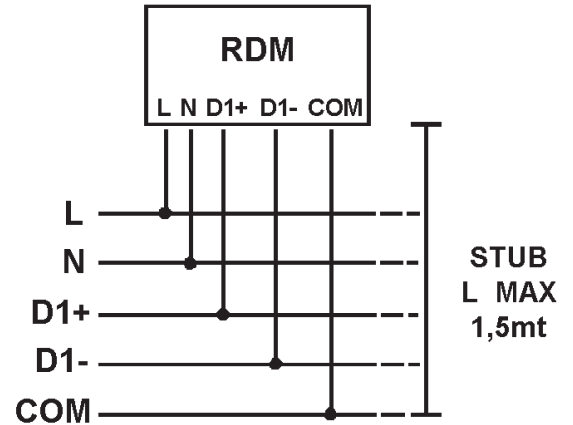
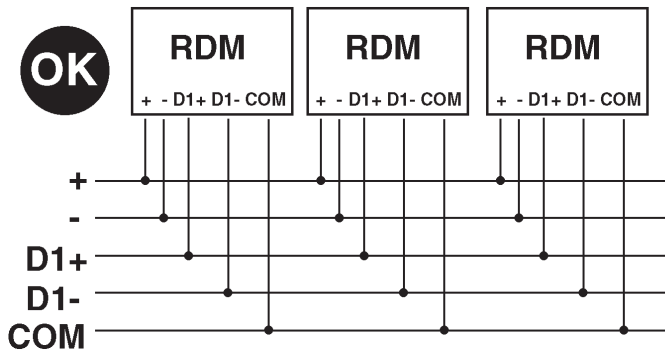

NO DMX

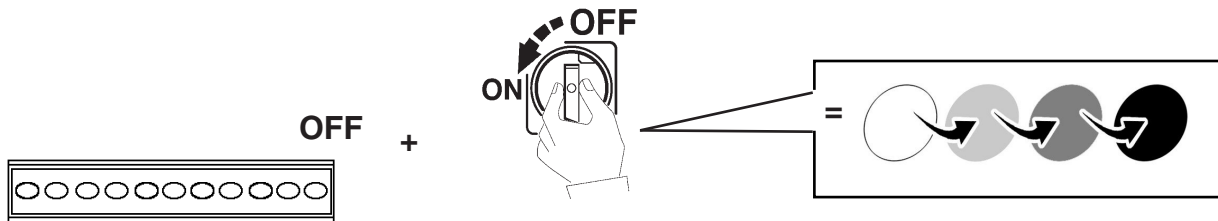

I "NON SI GARANTISCE IL SINCRONISMO DELLA RUOTA COLORI DI PIU' PRODOTTI ALIMENTATI SENZA SISTEMA DI CONTROLLO DMX".

GB "COLOUR WHEEL SYNCHRONISM NOT ENSURED IF SEVERAL PRODUCTS POWERED WITHOUT DMX CONTROL SYSTEM".

F « LE SYNCHRONISME DE LA ROUE DE COULEURS N'EST PAS ASSURÉ EN CAS DE PLUSIEURS APPAREILS ALIMENTÉS SANS SYSTÈME DE CONTRÔLE DMX ».

D "DER SYNCHRONLAUF DES FARBRADS MEHRERER PRODUKTE, DIE OHNE DMX-STEUERSYSTEM VERSORGT WERDEN, KANN NICHT GEWÄHRLEISTET WERDEN".

NL "DE SYNCHRONICITEIT VAN HET KLEURENWIJEL VAN MEERDERE PRODUCTEN WORDT NIET GEGARANDEERD ALS DEZE NIET WORDEN GEVOED DOOR EEN DMX CONTROLSTYSTEEM".

E "NO SE GARANTIZA EL SINCRONISMO DE LA VARIACIÓN CROMÁTICA EN CASO DE PRODUCTOS MÚLTIPLES ALIMENTADOS SIN SISTEMA DE CONTROL DMX".

DK "DER GIVES INGEN GARANTI FOR FARVESTYRINGENS SYNKRONISME FOR FLERE TILSLUTTEDE PRODUKTER UDEN DMX-STYRESYSTEM".

N «VI KAN IKKE GARANTERE SYNKRONISERING AV FARGEENDRINGEN I FLERE PRODUKTER SOM FUNGERER UTEN DMX KONTROLLSYSTEM».

S VI GARANTERAR INTE SYNKRONISERAD FÄRGGVÄXLING AV FLERA PRODUKTER SOM MATAS UTAN DMX-STYRSYSTEM.

RUS «НЕ ГАРАНТИРУЕТСЯ СИНХРОНИЗАЦИИ ВАРИАЦИИ ЦВЕТА НЕСКОЛЬКИХ ПРИБОРОВ, ЗАПИТАННЫХ БЕЗ СИСТЕМЫ КОНТРОЛЯ DMX".

CN "如果多个通电产品无 DMX 控制系统，则无法确保色轮同步。"

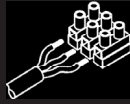

DMX

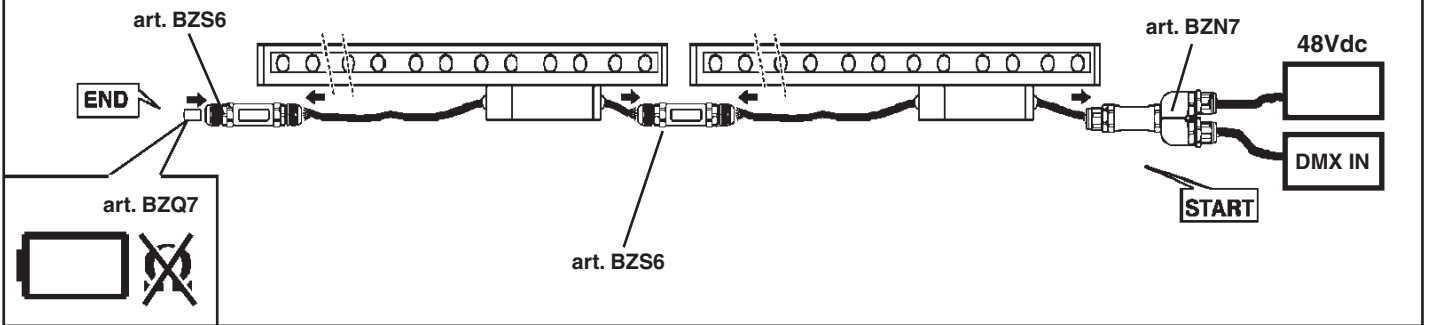
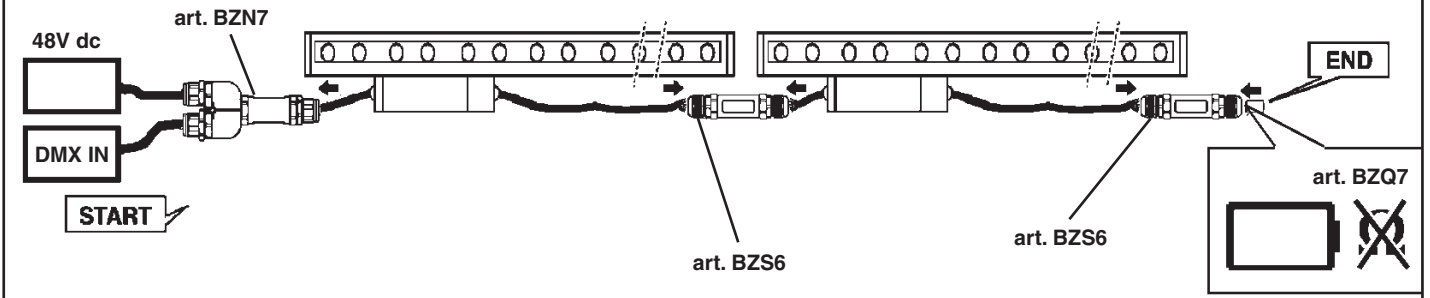

DMX

OK

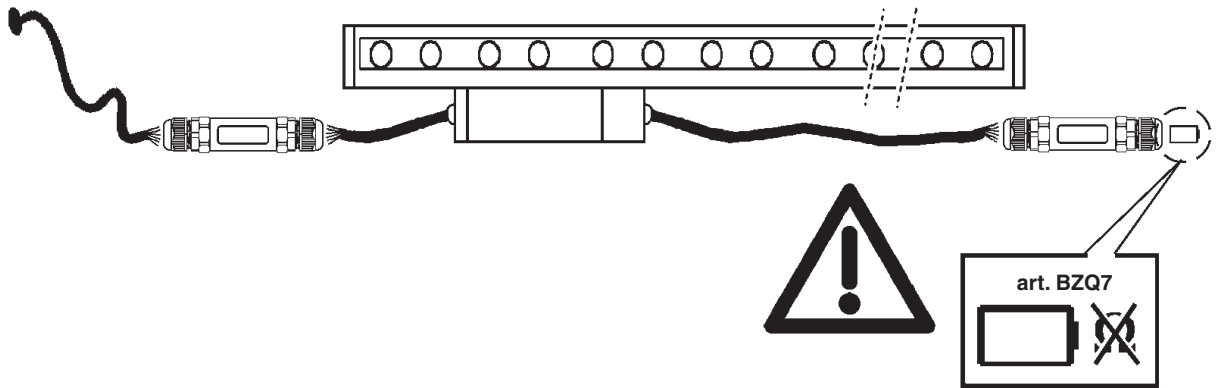

NO

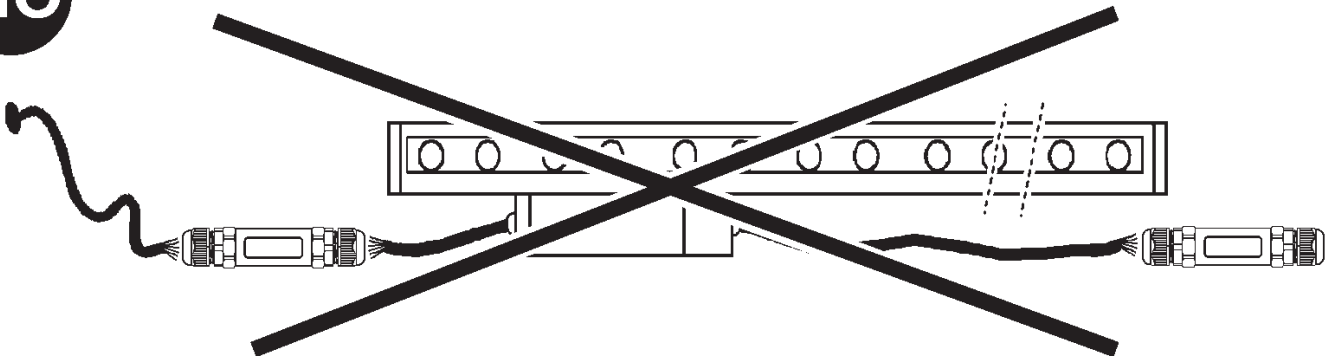

CALCOLO "L max " CAVI - CALCOLO "n° max " PRODOTTI
 TO CALCULATE MAXIMUM CABLE LENGTH - TO CALCULATE MAXIMUM NUMBER OF PRODUCTS
 CALCOLO "L max " CAVI / CALCUL "long maxi" de cable - CALCOLO "N° max " PRODOTTI / CALCUL "qté maxi" de produits
 KALKULATION MAXIMALE LÄNGE DER KABEL - KALKULATION MAXIMALE ANZAHL DER PRODUKTE
 BEREKENING "max L" kabels - BEREKENING "max aantal" PRODUCTEN
 CÁLCULO "L max " CABLE - CÁLCULO "n° max " PRODUCTOS
 BEREGNING "L max " KABLER - BEREGNING "N° max " PRODUKTER
 BEREGNING "maks. L" KABLER - BEREGNING "maks. ant." PRODUKTER
 BERÄKNING "max. L" KABLAR - BERÄKNING "max. antal" PRODUKTER
 РАСЧЁТ «МАКС. ДЛИНЫ» ПРОВОДОВ - РАСЧЁТ «МАКС. КОЛИЧЕСТВА» ПРИБОРОВ
 计算电缆最大长度 - 计算产品最大数量。

I Per calcolare la lunghezza del cavo Max:
 GB To calculate the max length of the cable:
 F Pour calculer la longueur maximale du câble :
 D Zur Berechnung der max. Kabellänge:
 NL Om de Max lengte van de kabel te calculeren:
 E Para calcular la longitud del cable Máx:
 DK For at beregne den maksimale kabellængde
 N For å beregne maksimal lengde på kabel:
 S För att beräkna max. kabellängd:
 RUS Для расчета макс. длины кабеля:
 CN 计算电缆线的最大长度 :

$$Lc[m] = \frac{\Delta x[V] * Sc[mm]^2}{2 * Np * I [A] * 0,0174}$$

I I moduli sono alimentati con una tensione in continua che varia tra (40V - 52V) RGB / (34V - 52V) MONOCROMATICO.
 GB The modules are powered with direct current ranging from (40V - 52V) RGB / (34V - 52V) MONOCROMATICO.
 F Les modules sont alimentés à une tension en courant continu comprise entre (40V - 52V) RGB / (34V - 52V) MONOCROMATICO.
 D Die Module werden mit einer Gleichstromspannung zwischen (40V - 52V) RGB / (34V - 52V) MONOCROMATICO versorgt.
 NL De modules worden gevoed door een continue spanning die varieert tussen de (40V - 52V) RGB / (34V - 52V) MONOCROMATICO.
 E Los módulos están alimentados con una tensión en corriente continua que varía entre (40V - 52V) RGB / (34V - 52V) MONOCROMATICO.
 DK For at beregne den maksimale kabellængde.
 N Modulene strømføres med en likestrøm som varierer mellom (40V - 52V) RGB / (34V - 52V) MONOCROMATICO.
 S Modulerna är matade med en likspänning som varierar mellan (40V - 52V) RGB / (34V - 52V) MONOCROMATICO.
 RUS Модули запитаны постоянным напряжением, которое варьируется в зависимости от версий - 40В- 52В для модулей с RGB LED и 34В-52В для модулей с Монохромными LED.
 CN 模块使用 (40V-52V) RGB至 (34V-52V) MONOCROMATICO的直流电源。

V in = 48 V

Δx = Caduta di tensione ammissibile tra alimentatore e la tensione minima di funzionamento del prodotto
 Δx = Allowed voltage drop between the power-supply unit and minimum operating voltage of the product
 Δx = Chute de tension admissible entre le ballast et la tension minimale de fonctionnement du produit
 Δx = Zulässiger Spannungsabfall zwischen Vorschaltgerät und Mindestbetriebsstrom des Produkts
 Δx = Een val van de spanning is toegestaan tussen het voorschakelapparaat en de minimum werkingsspanning van het product.
 Δx = Caída de tensión permitida entre el alimentador y la tensión mínima de funcionamiento del producto
 Δx = Tilladt spændingsfald mellem strømforsyning og produktets minimumsdriftsspænding
 Δx = Godkjent spenningsfall mellom transformatoren og produktets laveste driftsspøining
 Δx = Tillåtet spenningsfall mellan nätaggregat och minimispänningen för produktens funktion
 Δx = Допустимое падение напряжения между блоком питания и минимальным рабочим напряжением изделия
 Δx = 允许压降在产品的电源组件与最小工作电压之间

ESEMPIO - EXAMPLE - EXEMPLE - BEISPIEL - VOORBEELD - EJEMPLO
 EKSEMPEL - EXEMPEL - ПРИМЕР - 例子

Power-supply voltage = 52V \Rightarrow Δx = 52-34=18V
 Minimum product voltage = 34V

I Definire il numero di prodotti Max. (Np) in funzione della sezione del cavo utilizzata (Sc).
 GB Define the max number of products (Np) based on the cable section used (Sc).
 F Définir le nombre maximum de produits (Np) en fonction de la section de câble utilisée (Sc).
 D Die maximale Produktzahl (Np) im Verhältnis zum verwendeten Kabeldurchmesser (Sc) definieren.
 NL Bepaal het Max. aantal producten (Np) aan de hand van de diameter van de gebruikte kabel (Sc).
 E Definir el número de productos Máx. (Np) en función de la sección del cable utilizada (Sc).
 DK Definér det maksimale antal produkter (Np) i forhold til det anvendte kabels tværsnit (Sc)
 N Definere maksimalt antall produkter (Np) på grunnlag av tverrsnittet til ledningen som benyttes (Sc).
 S Ange max. antal produkter (Np) beroende på kabeltvärsnittet som används (Sc).
 RUS Максимальное количество приборов Max. (Np) определяется в зависимости от сечения используемого кабеля (Sc).
 CN 根据所用电缆的截面 (Sc) 确定产品数量的上限 (Np) 。

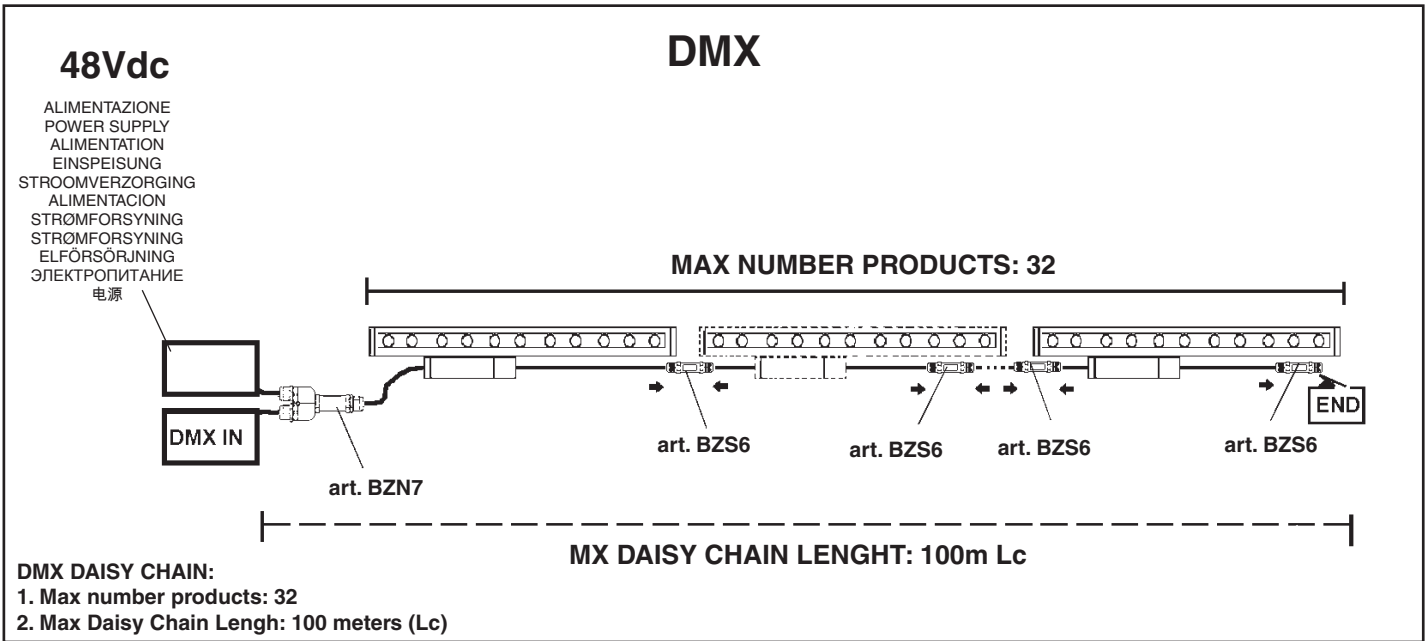

n° prodotti no. of products nbre de produits Anz. Produkte Aantal producten Cantidad de productos Anal produkter Antall produkter Antal produkter кол-во изделий 产品 数量 (Np)	SEZIONE DEL CAVO ESTERNO EXTERNAL WIRE CROSS-SECTION SECTION DU CÂBLE EXTÉRIEUR QUERSCHNITT DES AUßENKABELS DOORSNEDE VAN DE EXTERNE KABEL SECCION DEL CABLE EXTERNO SNIT PÅ EKSTERN LEDNING TVÄRRSNITT AV YTRE LEDNING TVÄRSNITT FÖR EXTERN KABEL СЕЧЕНИЕ ВНЕШНЕГО ПРОВОДА 外部电缆截面 (mm²) (Sc)	Lunghezza cavo Cable length Longueur du câble Kabellänge Lengte kabel Longitud cable Kabellængde Kabellengde Kabellängd Длина кабеля 电缆长度 Lc (m)	TENSIONE DI ALIMENTAZIONE POWER SUPPLY VOLTAGE TENSION D'ALIMENTATION VERSORGUNGSSPANNUNG VOEDINGSSPANNING TENSION DE ALIMENTACIÓN FORSYNINGSSPÆNDING SPENNING STRØMTILFØRSEL MATNINGSSPÄNNING напряжение электропитания 主电压 (V)
--	--	--	--

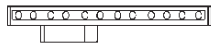

ALIMENTATORE - BALLAST - BALLAST - VORSCHALTGERÄT - VOORSCHAKELAPPARAAT - ALIMENTADOR - STRØMFORSYNINGSENHED - BALLAST - STRÖMFÖRSÖRJNINGANORDNING
 БЛОК ПИТАНИЯ - 电源

art. BZ14 100W Vin=100-120-240 Vac, 50/60Hz; Vout=34÷52 Vdc (Selv)

ART BL36 - BL37 - BM73 - BM74 - BM81 - BM82

15	1,5	100	52
----	-----	-----	----

ART BL38 - BL39 - BM75 - BM76 - BM83 - BM84

7	1,5	100	52
---	-----	-----	----

ART BL40 - BL41

4	1,5	100	52
---	-----	-----	----

ART BJ20

7	1,5	100	52
---	-----	-----	----

ART BJ21

3	1,5	100	52
---	-----	-----	----

ART BJ22

2	1,5	100	52
---	-----	-----	----

ALIMENTATORE - BALLAST - BALLAST - VORSCHALTGERÄT - VOORSCHAKELAPPARAAT - ALIMENTADOR - STRØMFORSYNINGSENHED - BALLAST - STRÖMFÖRSÖRJNINGANORDNING
 БЛОК ПИТАНИЯ - 电源

art. BZ15 240W Vin=100-240 Vac, 50/60Hz; Vout=34÷52 Vdc (Selv)

ART BL36 - BL37 - BM73 - BM74 - BM81 - BM82

32	1,5	100	52
----	-----	-----	----

ART BL38 - BL39 - BM75 - BM76 - BM83 - BM84

18	1,5	100	52
----	-----	-----	----

ART BL40 - BL41

11	1,5	100	52
----	-----	-----	----

ART BJ20

17	1,5	100	52
----	-----	-----	----

ART BJ21

9	1,5	100	52
---	-----	-----	----

ART BJ22

5	1,5	100	52
---	-----	-----	----

ALIMENTATORE - BALLAST - BALLAST - VORSCHALTGERÄT - VOORSCHAKELAPPARAAT - ALIMENTADOR - STRØMFORSYNINGSENHED - BALLAST - STRÖMFÖRSÖRJNINGANORDNING
 БЛОК ПИТАНИЯ - 电源

art. BZ16 480W Vin=100-240 Vac, 50/60Hz; Vout=34÷52 Vdc (Selv)

ART BL36 - BL37 - BM73 - BM74 - BM81 - BM82

32	1,5	87	52
----	-----	----	----

ART BL38 - BL39 - BM75 - BM76 - BM83 - BM84

21	1,5	89	52
----	-----	----	----

ART BL40 - BL41

14	1,5	89	52
----	-----	----	----

ART BJ20

30	1,5	58	52
----	-----	----	----

ART BJ21

16	1,5	60	52
----	-----	----	----

ART BJ22

9	1,5	61	52
---	-----	----	----



N.B.: DURANTE L'INSTALLAZIONE DEL SISTEMA "LINEALUCE" RISPETTARE SCRUPOLOSAMENTE LE NORME IMPIANTISTICHE NAZIONALI VIGENTI.

N.B.: WHEN INSTALLING THE "LINEALUCE" SYSTEM, MAKE SURE ALL CURRENT NATIONAL REGULATIONS RELATING TO INSTALLATION ARE OBSERVED.

N.B.: LORS DE L'INSTALLATION DU SYSTÈME "LINEALUCE" VEUILLEZ RESPECTER RIGOREUSEMENT LES NORMES EN VIGUEUR EN LA MATIÈRE DANS LE PAYS.

N.B.: BEACHTEN SIE BEI DER INSTALLATION DES SYSTEMS "LINEALUCE" UNBEDINGT DIE IM LAND GELTENDEN ANLAGETECHNISCHEN VORSCHRIFTEN.

N.B.: BIJ HET INSTALLEREN VAN HET "LINEALUCE" SYSTEEM MOET U DE GELDENDE NATIONALE INSTALLATIENORMEN STRIKT NALEVEN.

NOTA: DURANTE LA INSTALACIÓN DEL SISTEMA "LINEALUCE" RESPETAR ESCRUPULOSAMENTE LAS NORMAS NACIONALES DE INSTALACIÓN EN VIGOR.

N.B.: UNDER INSTALLATION AF "LINEALUCE" SYSTEMET SKAL MAN NØJE OVERHOLDE DE GÆLDENDE REGLER FOR DISSE ANLÆG.

N.B.: UNDER INSTALLASJON AV SYSTEMET "LINEALUCE" MÅ DE NASJONALE ANLEGGSFORSKRIFTFENE OVERHOLDES NØYE.

OBS! UNDER INSTALLATIONEN AV SYSTEMET "LINEALUCE" SKA GÄLLANDE NATIONELLA INSTALLATIONSFÖRESKRIFTER RESPEKTERAS I DETALJ.

ПРИМЕЧАНИЕ: В ПРОЦЕССЕ МОНТАЖА СИСТЕМЫ "LINEALUCE" СТРОГО СОБЛЮДАЙТЕ НАЦИОНАЛЬНЫЕ ДЕЙСТВУЮЩИЕ НОРМАТИВЫ ПО ЭЛЕКТРОПРОВОДКЕ.

重要：安装 'LINEALUCE' 系统时请始终参照标准系统

I N.B.: Per la sostituzione del LED contattare l'azienda iGuzzini.

GB N.B.: For information on LED replacement please contact iGuzzini.

F N.B.: Pour procéder au remplacement de la LED, adressez-vous à la société iGuzzini.

D N.B.: Bezüglich des Austausches der LED kontaktieren Sie bitte die Firma iGuzzini.

NL N.B.: Voor het vervangen van de LED neemt u contact op met het bedrijf iGuzzini.

E NOTA: Para sustituir el LED llame a la empresa iGuzzini.

DK N.B.: For udskiftning af lysdioden, skal man kontakte iGuzzini.

N N.B.: For informasjon om skifte av LED, vennligst ta kontakt med iGuzzini.

S OBS! För byte av lysdioden, kontakta företaget iGuzzini.

RUS ПРИМЕЧАНИЕ: Для замены СИДов обращайтесь в компанию iGuzzini.

CN 注意：如需LED更换的信息，请联系iGuzzini。

I In caso di danneggiamento del cavo elettrico con spina, la sostituzione deve essere effettuata dal costruttore, dal suo servizio di assistenza o da personale qualificato equivalente, al fine di evitare pericoli.

GB In the event of damage to the electric cable with plug, replacement must be carried out by the manufacturer, by the after-sales assistance of the same or by a qualified professional, in order to avoid all risk of danger.

F Si le câble électrique avec fiche est endommagé, faites-le remplacer par le fabricant, son service après-vente ou un professionnel du secteur, pour éviter tout risque de danger.

D Zur Vermeidung von Gefahren sind Elektrokabel und Stecker im Falle einer Beschädigung vom Hersteller, von dessen Kundendienst oder von spezialisiertem Fachpersonal auszuwechseln.

NL Mocht het elektrische snoer met stekker beschadigd raken, dan moet het vervangen ervan worden uitgevoerd door de fabrikant, zijn Technische Dienst of door een erkende installateur, teneinde gevaar te vermijden.

E En caso de daño del cable eléctrico con enchufe, la sustitución debe realizarse por el fabricante, su servicio de asistencia o bien personal especializado equivalente debido a razones de seguridad.

DK Hvis ledningen med stik beskadiges, skal den udskiftes af producenten eller er et autoriseret teknisk servicecenter, eller af kvalificerede fagfolk, så man undgår farlige situationer.

N I tilfelle skade på den elektriske kablen med plugg, må erstatning utføres av produsenten, gjennom ettersalgsavdelingen til denne eller av en kvalifisert fagperson, for å unngå all fare.

S Om elkabeln med stickkontakten skadas, ska den bytas ut av tillverkaren, av dess auktoriserade verkstad eller av likvärdig kvalificerad personal för att undvika alla typer av risker.

RUS В случае повреждения электрического кабеля со штепсельной вилкой во избежание риска поручите его замену производителю, уполномоченному сервису или квалифицированному электрику.

CN 如出现带插头电缆的损坏，须由生产商、售后服务助理或资深专业人员更换新的电缆，以避免任何可能的危险。



I In caso di rottura delle lenti il prodotto non può essere utilizzato, contattare il costruttore per la sua sostituzione.

GB Should the lenses break, the product cannot be used. Contact the manufacturer for replacement.

F En cas de rupture des lentilles, le produit ne peut plus être utilisé. Contacter le fabricant pour procéder à son remplacement.

D Im Falle einer Beschädigung der Linsen darf das Produkt nicht verwendet werden. Setzen Sie sich bitte mit dem Hersteller in Verbindung, der für den Ersatz sorgen wird.

NL Indien de lenzen kapot zijn kan het product niet geïnstalleerd worden. Neem contact op met de fabrikant om ze te vervangen.

E En caso de rotura de las lentes, el producto no puede utilizarse y se debe contactar con el fabricante para su sustitución.

DK Hvis produktets linser ødelægges, kan det ikke anvendes. Kontakt producenten med henblik på udskiftning.

N Hvis linsene blir ødelagt kan ikke produktet brukes lenger. Ta kontakt med produsenten for å få det skiftet ut.

S Produkten kan inte användas vid brott på linser. Kontakta tillverkaren för byte av linser.

RUS В случае повреждения линз прибор нельзя использовать, обратиться к производителю для его замены.

CN 如果镜头破裂，请不要使用该产品。请联系制造商进行更换。

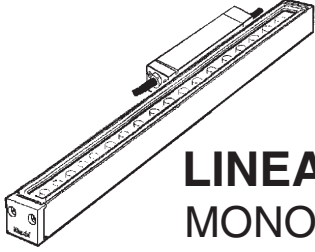

LINEALUCE MINI 37 MONOCHROME - RGB (DMX - RDM)

تحذير:

لا يمكن ضمان سلامة هذا الجهاز إلا إذا التزمت بهذه التعليمات. يجب حفظها في مكان آمن.

ATTENZIONE:

LA SICUREZZA DELL'APPARECCHIO E' GARANTITA SOLO CON L'USO APPROPRIATO DELLE SEGUENTI ISTRUZIONI; PERTANTO E' NECESSARIO CONSERVARLE.

WARNING:

THE SAFETY OF THIS FIXTURE IS GUARANTEED ONLY IF YOU COMPLY WITH THESE INSTRUCTIONS; REMEMBER TO CONSERVE IN A SAFE PLACE.

ATENCION:

LA SEGURIDAD DEL APARATO SE GARANTIZA SOLO CUMPLIENDO CUIDADOSAMENTE LAS SIGUIENTES INSTRUCCIONES; POR ELLO, ES NECESARIO CONSERVARLAS.

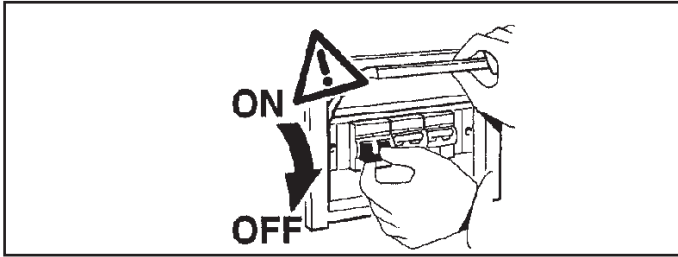
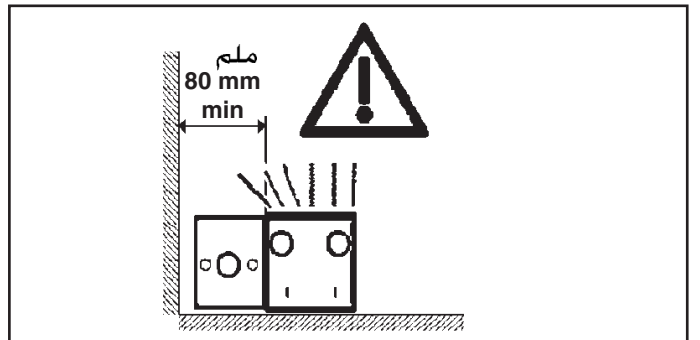
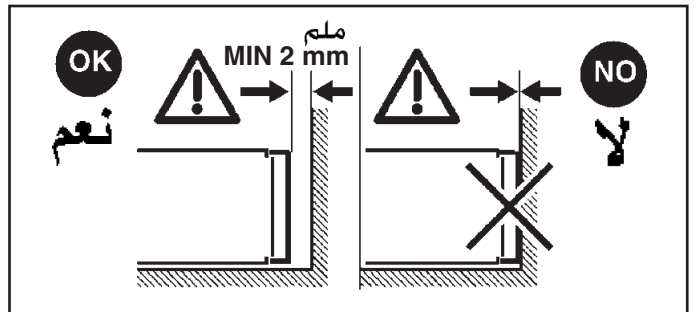
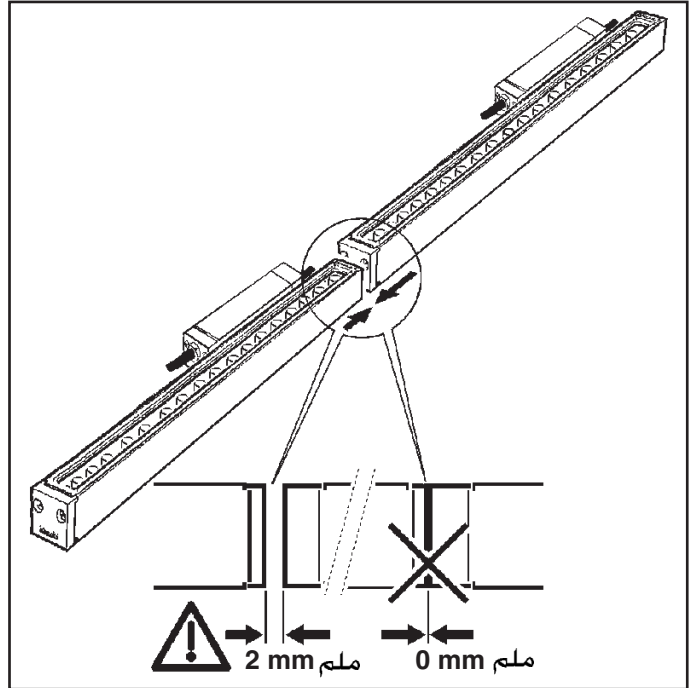
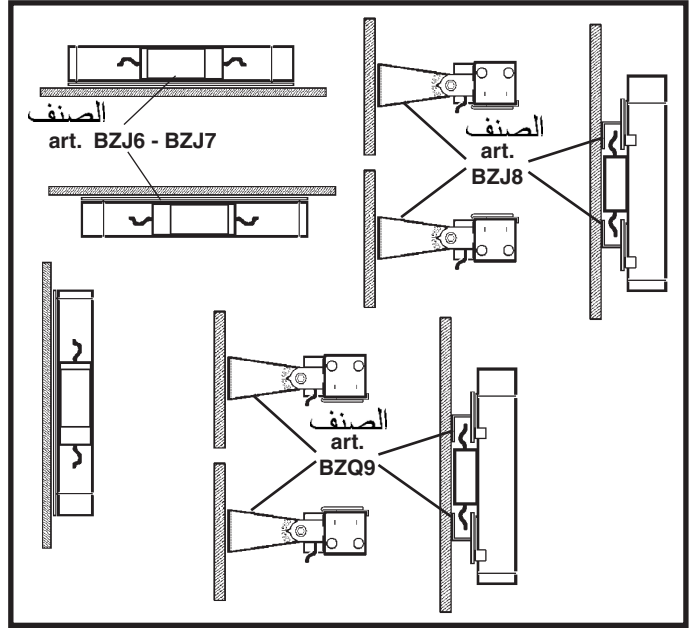

الصنف ART.	ملم L (mm)
	BL36 - BL37 - BM73 - BM74 BM81 - BM82 - BJ20
BL38 - BL39 - BM75 - BM76 BM83 - BM84	1040
BL40 - BL41	1570
BJ21	1004
BJ22	1496

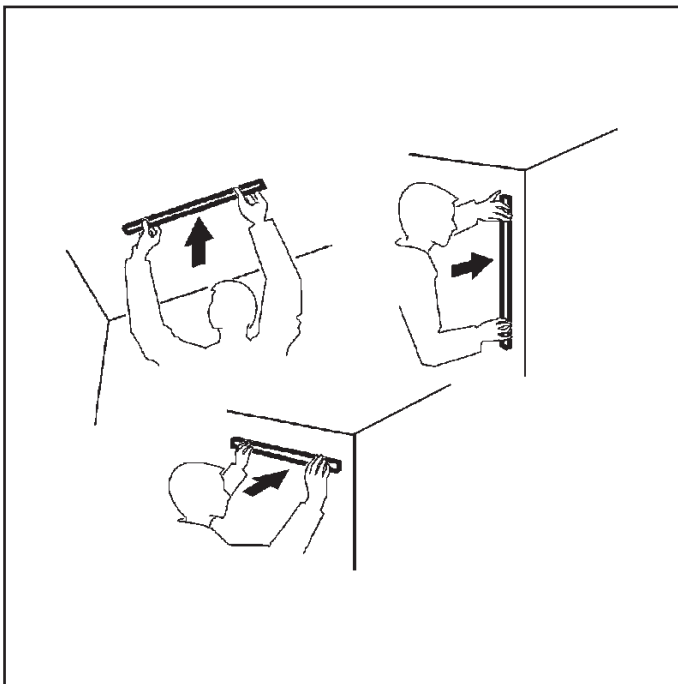

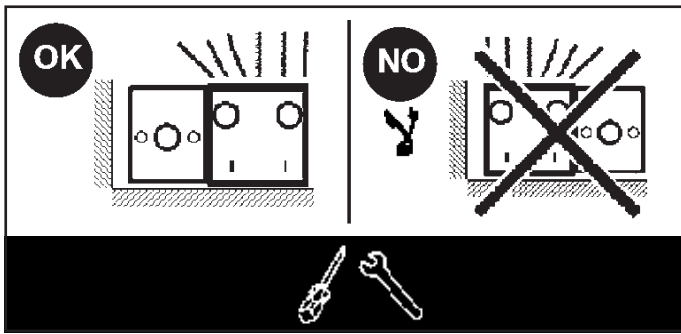

تركيب الدعائم الميكانيكية

INSTALLAZIONE DEI SUPPORTI MECCANICI
 INSTALLATION OF THE MECHANICAL SUPPORTS
 INSTALACIÓN DE LOS SOPORTES MECÁNICOS

جدول مسافات الفتحات من المركز للمركز
 TABELLA INTERASSI DI FORATURA
 TABLE - CENTRE TO CENTRE DISTANCE BETWEEN HOLES
 TALADRAR DISTANCIA ENTRE LOS EJES DE PERFORACIÓN

الصف ART.	BZJ8 BZQ9 ملم K (mm)	BZJ6 ملم K (mm)	BZJ7 ملم K (mm)
BL36 - BL37 - BM73 - BM74 MB81 - MB82 - BJ20	318		
BJ21	810	265	/
BL38 - BL39 - BM75 - BM76 BM83 - BM84	846		
BJ22	1299	/	600
BL40 - BL41	1375		

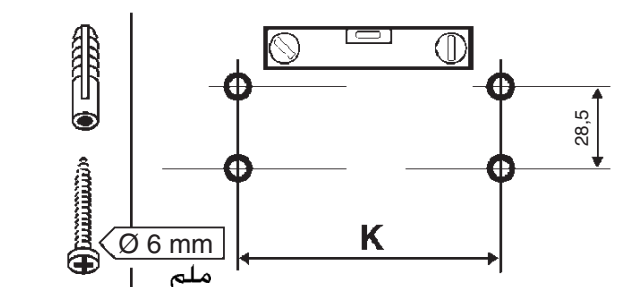
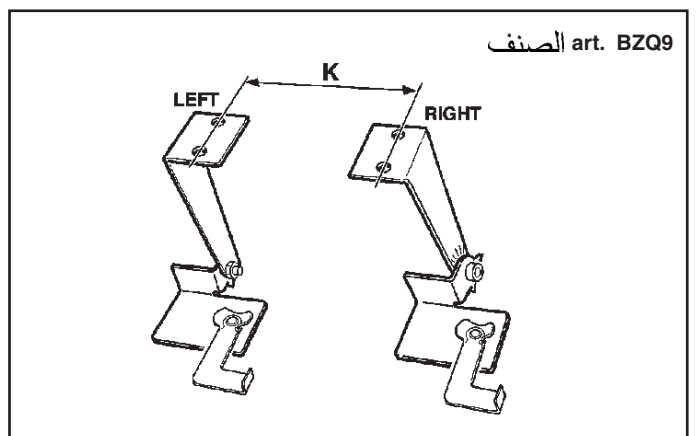
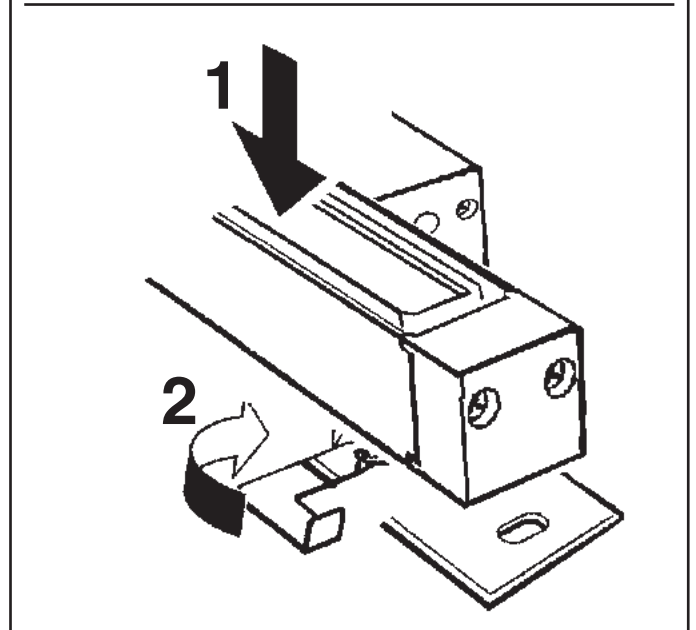
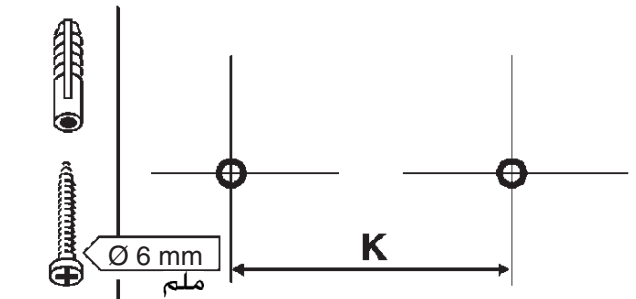
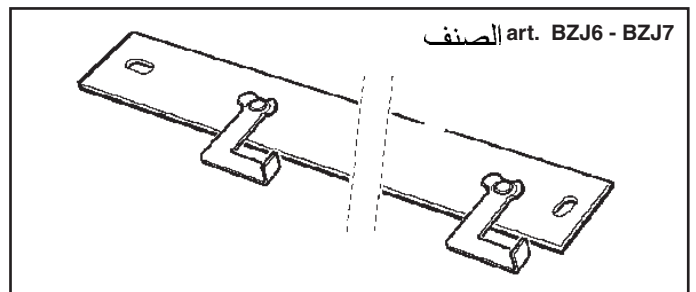
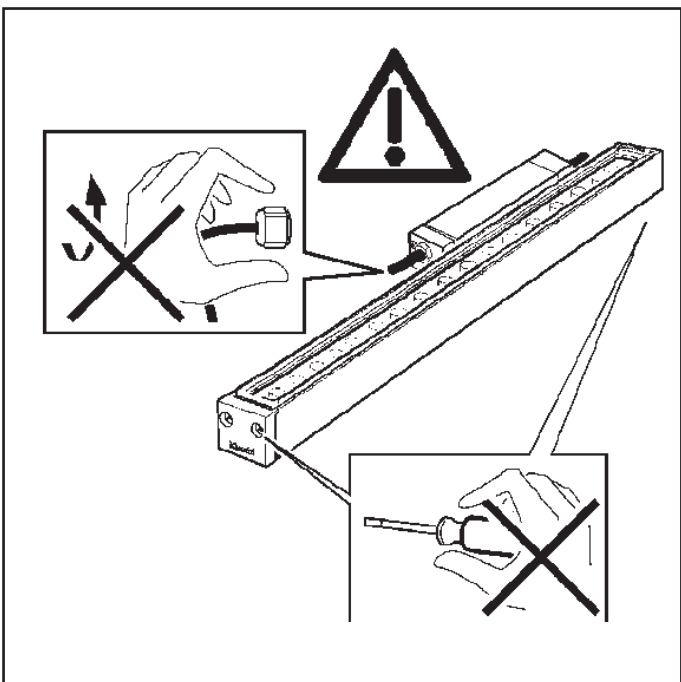
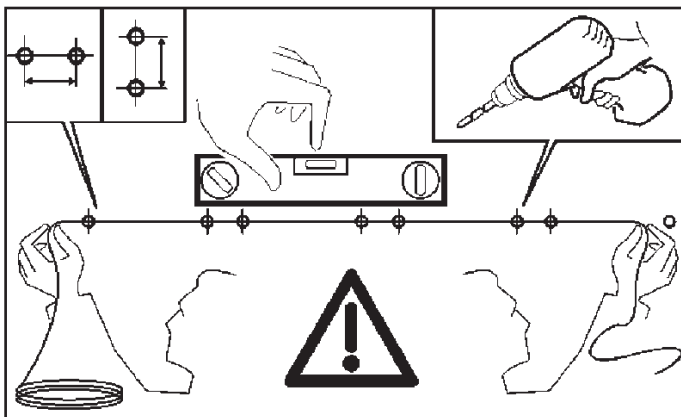

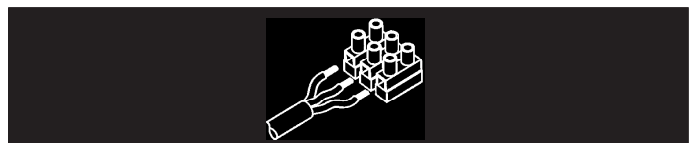
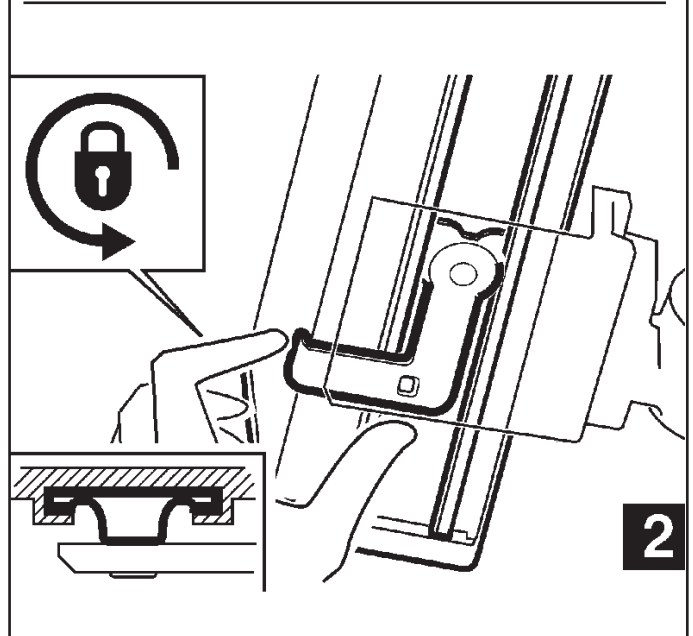
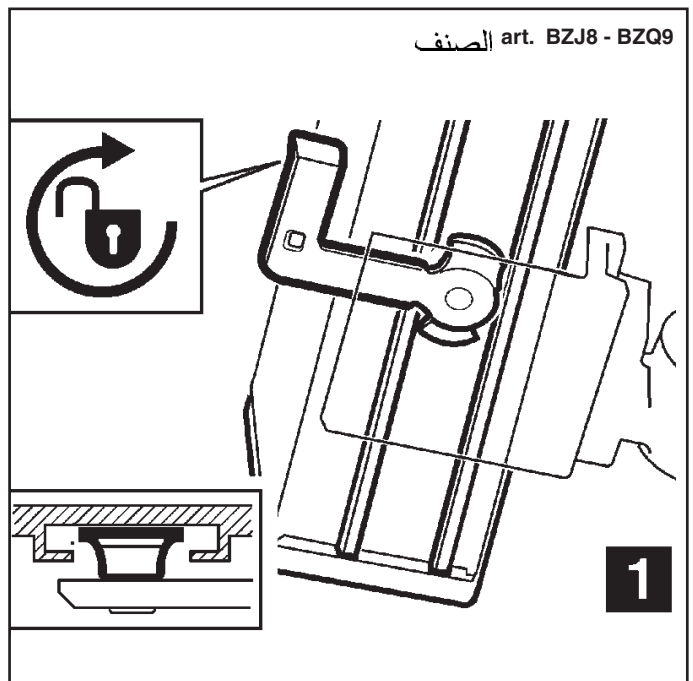
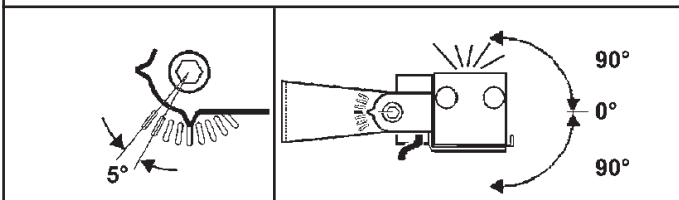
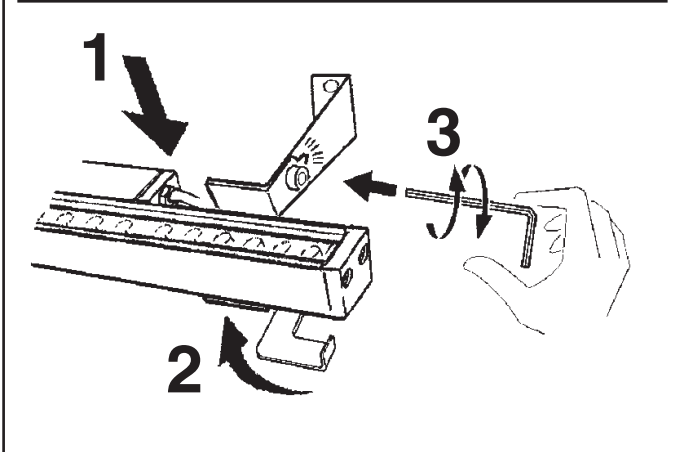
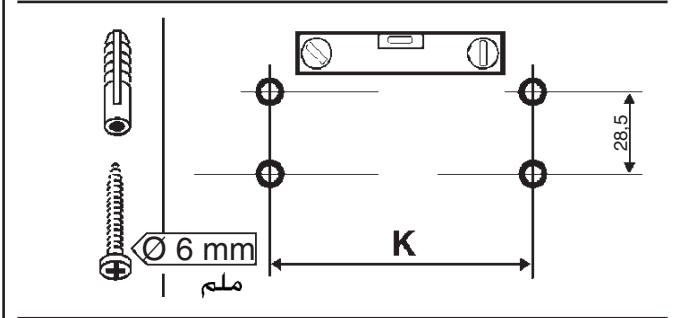
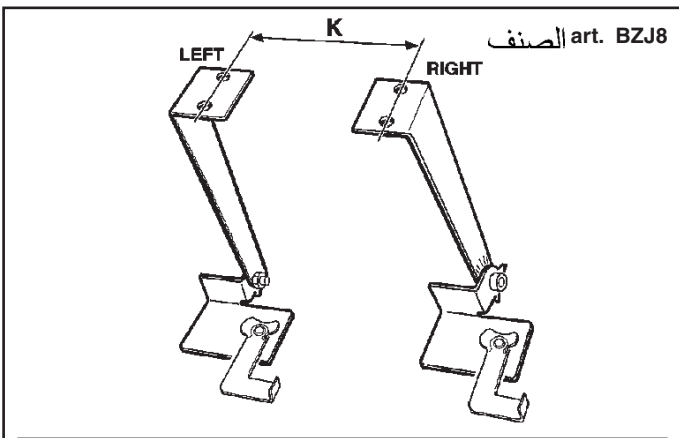
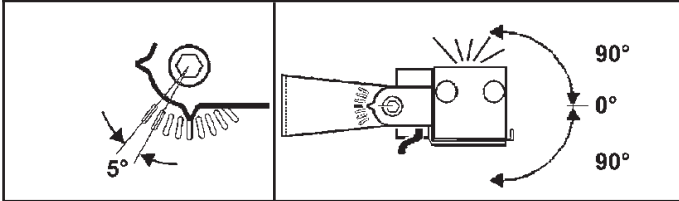
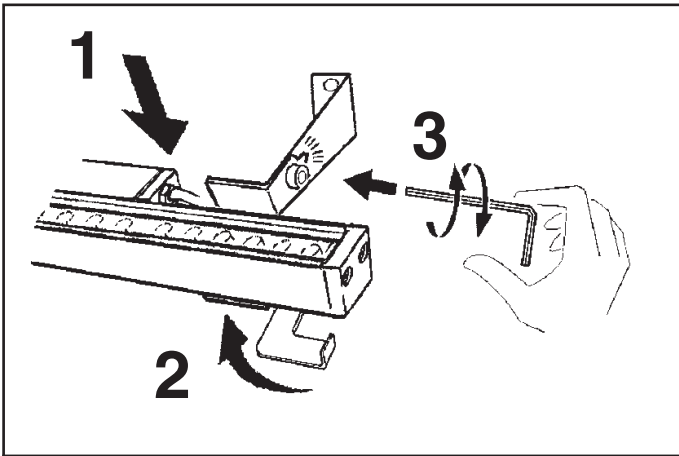

RGB	MIN 40Vdc MAX 52Vdc	48Vdc
MONOCROMATICO	MIN 34Vdc MAX 52Vdc	

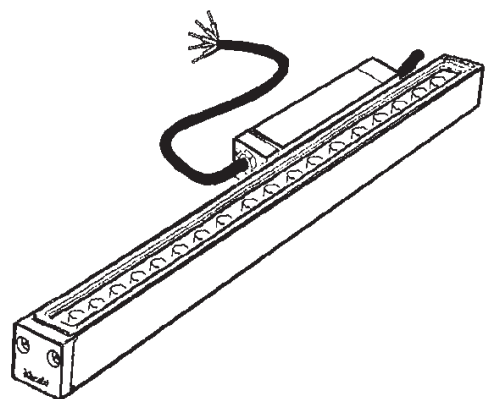

art. BZS6
الصف

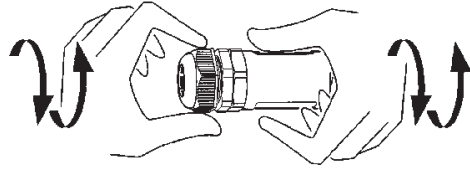

DMX

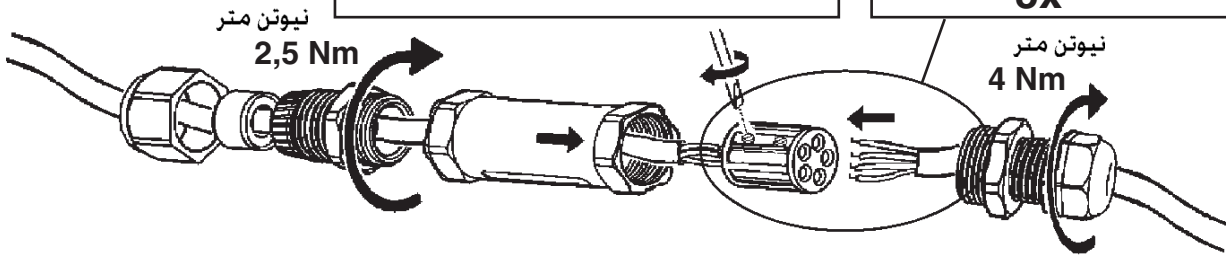
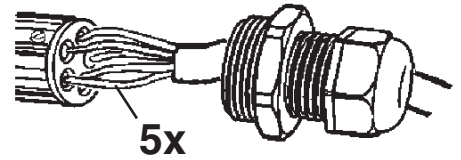

DMX

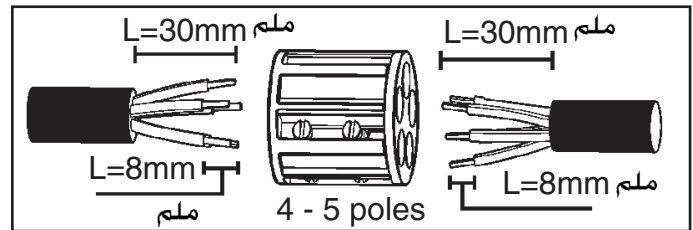
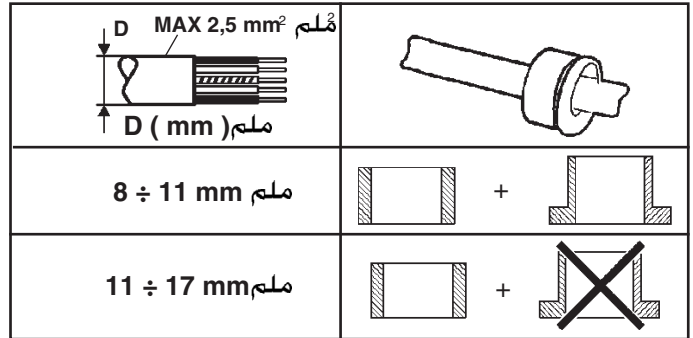
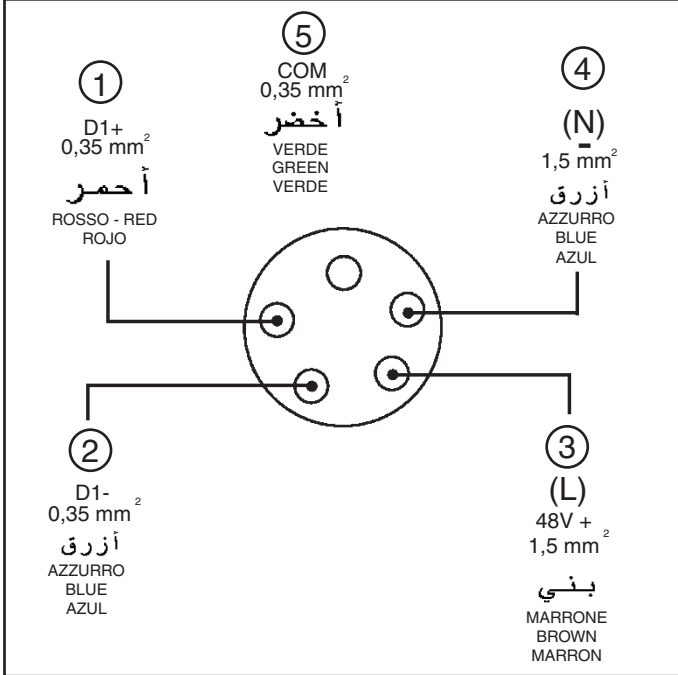

ملحوظة هامة: لإنهاء خط نظام التحكم في الأضواء الرقمي المتعدد "DMX" ضع في آخر وحدة المنتج BZQ7.

I N.B.: Per chiudere la linea DMX inserire sull'ultimo modulo l'art. BZQ7.

GB N.B.: To close the DMX line, add item BZQ7 onto the last module.

E Nota: Para cerrar la línea DMX introducir en el último módulo el art. BZQ7.

Product version	ADDRESSES n°	ADDRESSES			
		1	2	3	4
Monochrome	1	White			
WNC	3	Warm	Neutral	Cool	
RGB	3	Red	Green	Blue	
WRGB	4	Red	Green	Blue	White
WRGBW	4	Red	Green	Blue	White



تأكد من صحة توصيل الأقطاب قبل إمداد الجهاز بالتيار الكهربائي.
التوصيل غير الصحيح يُمكن أن يتسبب في عدم عمل الأجهزة بشكل صحيح.

I Prima di alimentare l'impianto assicurarsi del corretto collegamento delle polarità. Un errato collegamento può comportare il malfunzionamento dei prodotti.

GB Before powering the system, make sure polarities were properly connected. Incorrect connection may cause the product to malfunction.

E Antes de alimentar la instalación compruebe que la conexión de las polaridades sea correcta. Una conexión incorrecta puede ocasionar el malfunzionamiento de los productos.

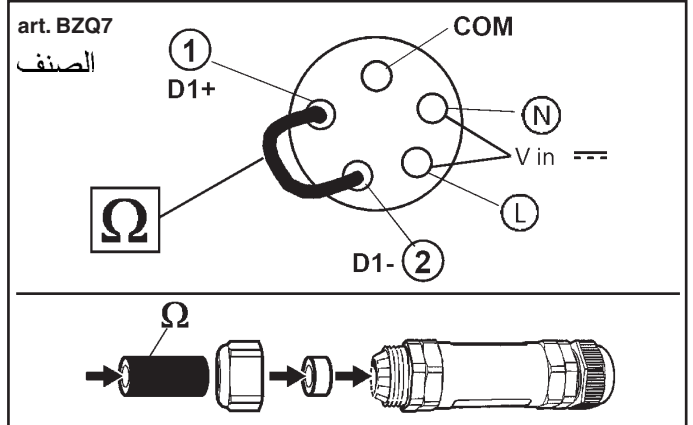

examples

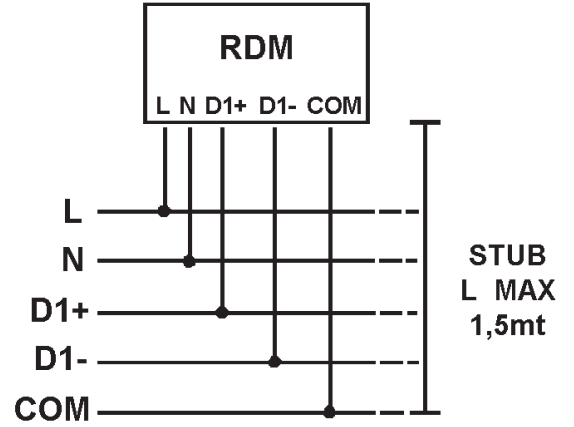
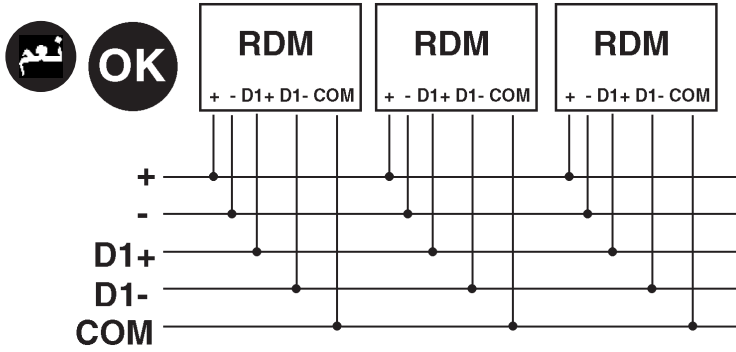

NO DMX

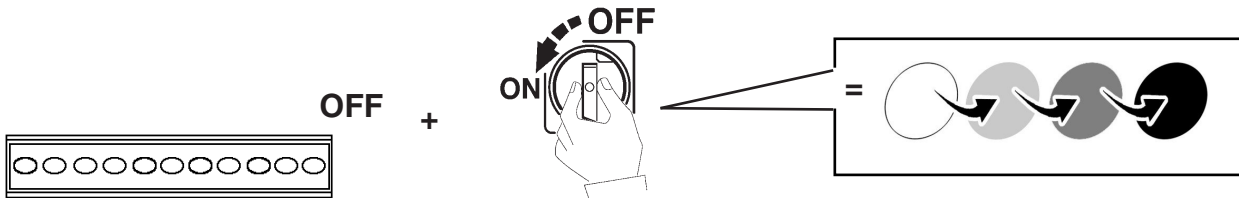

"لا يمكن ضمان تزامن تنوع الألوان لمنتجات أخرى تعمل بالطاقة الكهربائية بدون نظام التحكم DMX".

I "NON SI GARANTISCE IL SINCRONISMO DELLA RUOTA COLORI DI PIU' PRODOTTI ALIMENTATI SENZA SISTEMA DI CONTROLLO DMX".

GB "COLOUR WHEEL SYNCHRONISM NOT ENSURED IF SEVERAL PRODUCTS POWERED WITHOUT DMX CONTROL SYSTEM".

E "NO SE GARANTIZA EL SINCRONISMO DE LA VARIACIÓN CROMÁTICA EN CASO DE PRODUCTOS MÚLTIPLES ALIMENTADOS SIN SISTEMA DE CONTROL DMX".

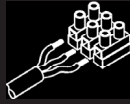

DMX

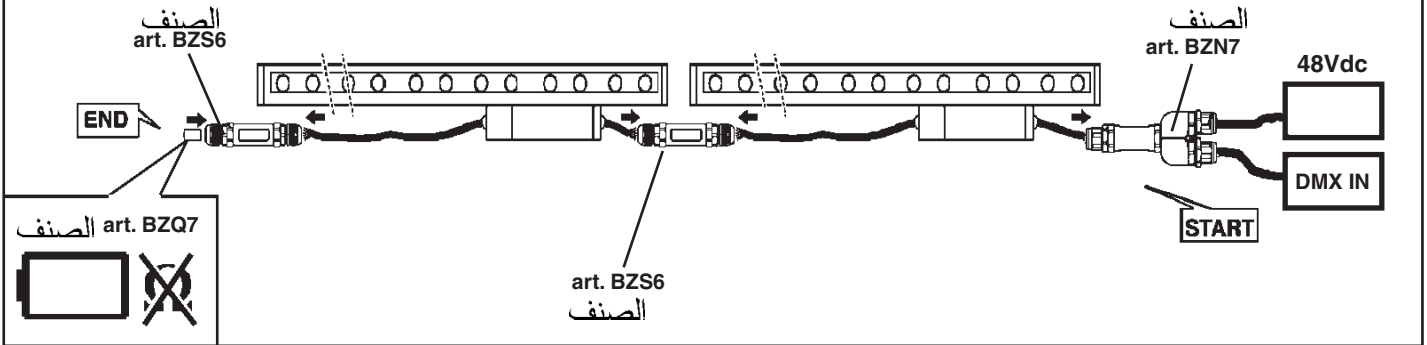
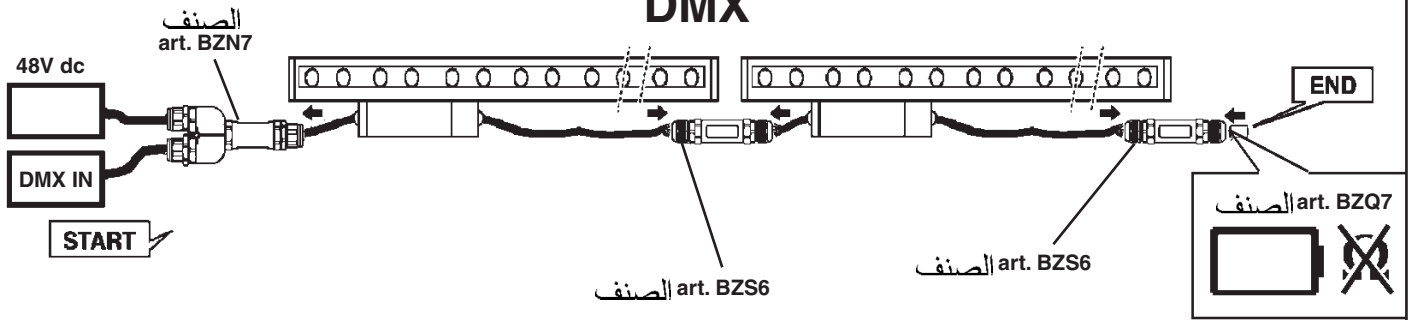

DMX

نعم **OK**

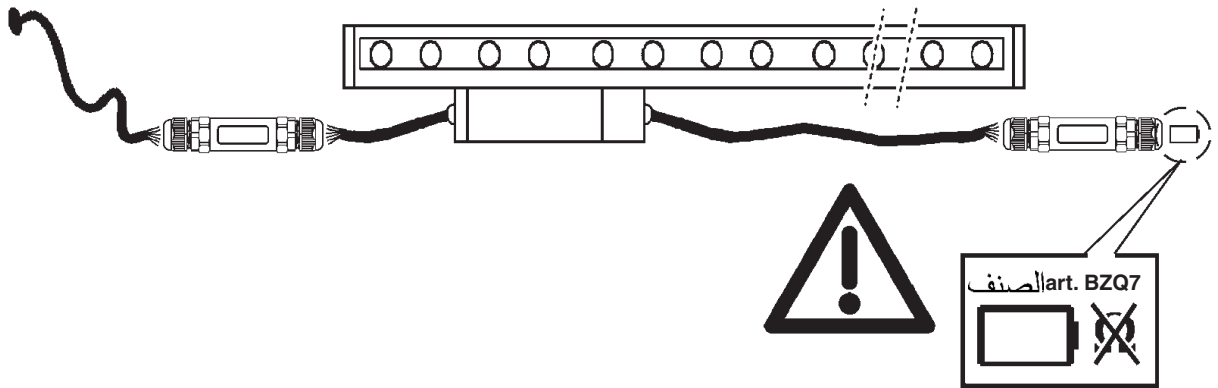

NO

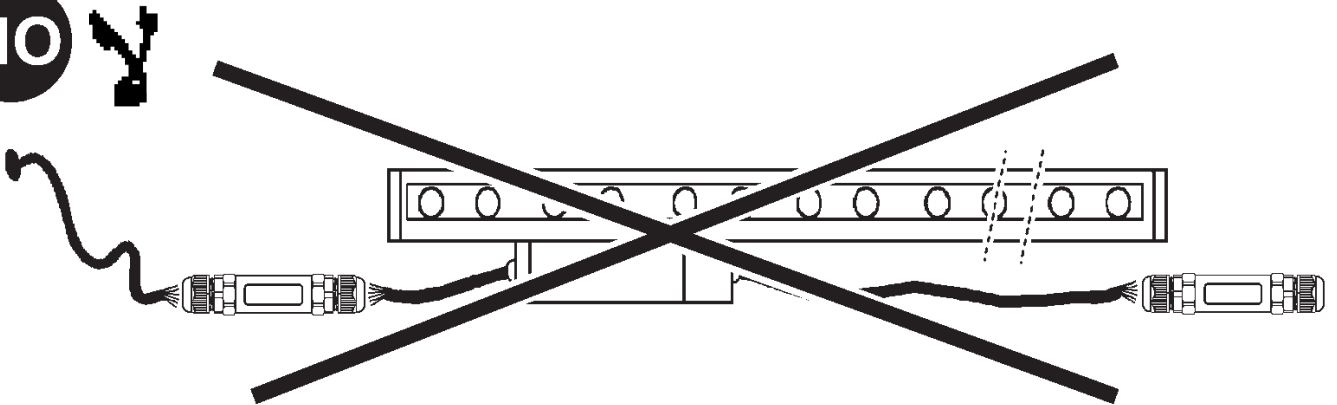

حساب أقصى طول للكابلات - حساب أقصى عدد للمنتجات

CALCOLO "L max " CAVI -
 CALCOLO "n° max " PRODOTTI
 TO CALCULATE MAXIMUM CABLE LENGTH -
 TO CALCULATE MAXIMUM NUMBER OF PRODUCTS
 CÁLCULO "L max " CABLE -
 CÁLCULO "n° max " PRODUCTOS

حساب أقصى طول للكابلات:

- I Per calcolare la lunghezza del cavo Max:
- GB To calculate the max length of the cable:
- E Para calcular la longitud del cable Máx:

$$Lc[m] = \frac{\Delta x[V] * Sc[mm]^2}{2 * Np * I [A] * 0,0174}$$

ع هذه الطرازات مزودة بتغذية كهربائية مستمرة تتراوح ما بين (40 فولت - 52 فولت) آر. جي. بي / (34 فولت - 52 فولت) أحادية اللون.

- I I moduli sono alimentati con una tensione in continua che varia tra (40V - 52V) RGB / (34V - 52V) MONOCROMATICO.
- GB The modules are powered with direct current ranging from (40V - 52V) RGB / (34V - 52V) MONOCROMATICO.
- E Los módulos están alimentados con una tensión en corriente continua que varía entre (40V - 52V) RGB / (34V - 52V) MONOCROMATICO.

V in = 48 V

انخفاض التيار المقبول بين وحدة التغذية وأدنى جهد لتشغيل المنتج.

- Δ x = Caduta di tensione ammissibile tra alimentatore e la tensione minima di funzionamento del prodotto
- Δ x = Allowed voltage drop between the power-supply unit and minimum operating voltage of the product
- Δ x = Caída de tensión permitida entre el alimentador y la tensión mínima de funcionamiento del producto

مثال

ESEMPIO - EXAMPLE
 EJEMPLO

Power-supply voltage = 52V

Minimum product voltage = 34V



$$\Delta x = 52-34=18V$$

حدد أقصى عدد للمنتجات (Np) وفقاً لمقطع الكابل المستخدم (Sc).

- I Definire il numero di prodotti Max. (Np) in funzione della sezione del cavo utilizzata (Sc).
- GB Define the max number of products (Np) based on the cable section used (Sc).
- E Definir el número de productos Máx. (Np) en función de la sección del cable utilizada (Sc).

48Vdc

DMX

مصدر التيار
 ALIMENTAZIONE
 POWER SUPPLY
 CEBADOR

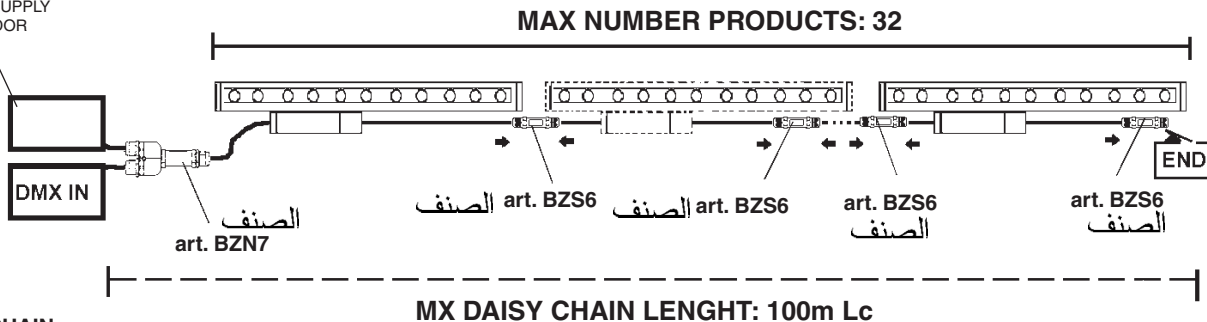

DMX DAISY CHAIN:

1. Max number products: 32
2. Max Daisy Chain Length: 100 meters (Lc)

عدد المنتجات n° prodotti no. of products Cantidad de productos (Np)	مقطع الكابل الخارجي SEZIONE DEL CAVO ESTERNO EXTERNAL WIRE CROSS- SECTION SECCIÓN DEL CABLE ESTERNO (mm ²) (Sc)	الطول كابل Lunghezza cavo Cable length Longitud cable Lc (m)	جهد التغذية TENSIONE DI ALI- MENTAZIONE POWER SUPPLY TENSIÓN DE ALI- MENTACIÓN (V)
--	--	--	--

ALIMENTATORE - BALLAST - ALIMENTADOR **كابح**

الصف **art. BZ14 100W Vin=100-120-240 Vac, 50/60Hz; Vout=34:52 Vdc (Selv)**

ART BL36 - BL37 - BM73 - BM74 - BM81 - BM82

15	1,5	100	52
----	-----	-----	----

ART BL38 - BL39 - BM75 - BM76 - BM83 - BM84

7	1,5	100	52
---	-----	-----	----

ART BL40 - BL41

4	1,5	100	52
---	-----	-----	----

ART BJ20

7	1,5	100	52
---	-----	-----	----

ART BJ21

3	1,5	100	52
---	-----	-----	----

ART BJ22

2	1,5	100	52
---	-----	-----	----

ALIMENTATORE - BALLAST - ALIMENTADOR **كابح**

الصف **art. BZ15 240W Vin=100-240 Vac, 50/60Hz; Vout=34:52 Vdc (Selv)**

ART BL36 - BL37 - BM73 - BM74 - BM81 - BM82

32	1,5	100	52
----	-----	-----	----

ART BL38 - BL39 - BM75 - BM76 - BM83 - BM84

18	1,5	100	52
----	-----	-----	----

ART BL40 - BL41

11	1,5	100	52
----	-----	-----	----

ART BJ20

17	1,5	100	52
----	-----	-----	----

ART BJ21

9	1,5	100	52
---	-----	-----	----

ART BJ22

5	1,5	100	52
---	-----	-----	----

ALIMENTATORE - BALLAST - ALIMENTADOR **كابح**

الصف **art. BZ16 480W Vin=100-240 Vac, 50/60Hz; Vout=34:52 Vdc (Selv)**

ART BL36 - BL37 - BM73 - BM74 - BM81 - BM82

32	1,5	87	52
----	-----	----	----

ART BL38 - BL39 - BM75 - BM76 - BM83 - BM84

21	1,5	89	52
----	-----	----	----

ART BL40 - BL41

14	1,5	89	52
----	-----	----	----

ART BJ20

30	1,5	58	52
----	-----	----	----

ART BJ21

16	1,5	60	52
----	-----	----	----

ART BJ22

9	1,5	61	52
---	-----	----	----



ملاحظة: ملاحظة: أثناء تركيب نظام "LINEALUCE". يجب التقيد بحرص بالنظم السائدة المتعلقة بالشبكة الكهربائية.

N.B.: DURANTE L'INSTALLAZIONE DEL SISTEMA "LINEALUCE" RISPETTARE SCRUPOLOSAMENTE LE NORME IMPIANTISTICHE VIGENTI.

N.B.: WHEN INSTALLING THE SYSTEM "LINEALUCE", STRICTLY COMPLY WITH ALL REGULATIONS ON INSTALLATION IN FORCE.

N.B.: DURANTE LA INSTALACIÓN DEL SISTEMA "LINEALUCE" RESPETAR ESCRUPULOSAMENTE LAS NORMAS DE INSTALACIÓN VIGENTES.

في حالة تلف الكبل الكهربائي، يجب استبداله من قبل الشركة المصنعة أو قسم المساعدة والرعاية التابع لها أو من قبل شخص ماهر لهذا الغرض، نتلاشى الأخطار ووقوع الحوادث.

I In caso di danneggiamento del cavo elettrico, la sostituzione deve essere effettuata dal costruttore, dal suo servizio di assistenza o da personale qualificato equivalente, al fine di evitare pericoli.

GB In the event of damage to the electric cable, replacement must be carried out by the manufacturer, by the after-sales assistance of the same or by a qualified professional, in order to avoid all risk of danger.

E En caso de daño del cable eléctrico, la sustitución debe realizarse por el fabricante, su servicio de asistencia o bien personal especializado equivalente debido a razones de seguridad.



لا يمكن استخدام هذا المنتج في حالة وجود كسر في العدسات، ومن ثم يجب الاتصال بالشركة المصنعة لاستبدال العدسات المكسورة.

I In caso di rottura delle lenti il prodotto non può essere utilizzato, contattare il costruttore per la sua sostituzione.

GB Should the lenses break, the product cannot be used. Contact the manufacturer for replacement.

E En caso de rotura de las lentes, el producto no puede utilizarse y se debe contactar con el fabricante para su sustitución.

تنبيه: لاستبدال الضوء LED اتصل بشركة iGuzzini .

I N.B.: Per la sostituzione del LED contattare l'azienda iGuzzini.

GB N.B.: For information on LED replacement please contact iGuzzini.

E NOTA: Para sustituir el LED llame a la empresa iGuzzini.

iGuzzini

2.516.881.02

ISO7085/03

ART	corrente assorbita (A) absorbed current courant absorbé Stromaufnahme stroomopname corriente absorbida absorberet strøm absorbert strøm tillförd ström поглощаемая мощность 电源电流	TENSIONE DI ALIMENTAZIONE POWER SUPPLY VOLTAGE TENSION D'ALIMENTATION VERSORGUNGSSPANNUNG VOEDINGSSPANNING TENSIÓN DE ALIMENTACIÓN FORSYNINGSSPÆNDING SPENNING STRØMTILFØRSEL MATNINGSSPÅNNING НАПРЯЖЕНИЕ ЭЛЕКТРОПИТАНИЯ 电源电压 (V)
BL30 - BL31 - BL36 - BL37 BM69 - BM70 - BM73 - BM74 BM77 - BM78 - BM81 - BM82	0,150	34 ÷ 52
BL32 - BL33 - BL38 - BL39 BM71 - BM72 - BM75 - BM76 BM79 - BM80 - BM83 - BM84	0,310	
BL34 - BL35 - BL40 - BL41	0,445	
BJ17 - BJ20	0,297	40 ÷ 52
BJ18 - BJ21	0,545	
BJ19 - BJ22	0,600	

iGuzzini

2.516.881.02

ISO7085/03

ART	corrente assorbita (A) absorbed current courant absorbé Stromaufnahme stroomopname corriente absorbida absorberet strøm absorbert strøm tillförd ström поглощаемая мощность 电源电流	НАПРЯЖЕНИЕ ЭЛЕКТРОПИТАНИЯ 电源电压
BL30 - BL31 - BL36 - BL37 BM69 - BM70 - BM73 - BM74 BM77 - BM78 - BM81 - BM82	0,150	34 ÷ 52
BL32 - BL33 - BL38 - BL39 BM71 - BM72 - BM75 - BM76 BM79 - BM80 - BM83 - BM84	0,310	
BL34 - BL35 - BL40 - BL41	0,445	
BJ17 - BJ20	0,297	40 ÷ 52
BJ18 - BJ21	0,545	
BJ19 - BJ22	0,600	

iGuzzini

2.516.881.02

ISO7085/03

ART	corrente assorbita (A) absorbed current courant absorbé Stromaufnahme stroomopname corriente absorbida absorberet strøm absorbert strøm tillförd ström поглощаемая мощность 电源电流	НАПРЯЖЕНИЕ ЭЛЕКТРОПИТАНИЯ 电源电压
BL30 - BL31 - BL36 - BL37 BM69 - BM70 - BM73 - BM74 BM77 - BM78 - BM81 - BM82	0,150	34 ÷ 52
BL32 - BL33 - BL38 - BL39 BM71 - BM72 - BM75 - BM76 BM79 - BM80 - BM83 - BM84	0,310	
BL34 - BL35 - BL40 - BL41	0,445	
BJ17 - BJ20	0,297	40 ÷ 52
BJ18 - BJ21	0,545	
BJ19 - BJ22	0,600	

iGuzzini

2.516.881.02

ISO7085/03

ART	corrente assorbita (A) absorbed current courant absorbé Stromaufnahme stroomopname corriente absorbida absorberet strøm absorbert strøm tillförd ström поглощаемая мощность 电源电流	НАПРЯЖЕНИЕ ЭЛЕКТРОПИТАНИЯ 电源电压
BL30 - BL31 - BL36 - BL37 BM69 - BM70 - BM73 - BM74 BM77 - BM78 - BM81 - BM82	0,150	34 ÷ 52
BL32 - BL33 - BL38 - BL39 BM71 - BM72 - BM75 - BM76 BM79 - BM80 - BM83 - BM84	0,310	
BL34 - BL35 - BL40 - BL41	0,445	
BJ17 - BJ20	0,297	40 ÷ 52
BJ18 - BJ21	0,545	
BJ19 - BJ22	0,600	

iGuzzini

2.516.881.02

ISO7085/03

ART	corrente assorbita (A) absorbed current courant absorbé Stromaufnahme stroomopname corriente absorbida absorberet strøm absorbert strøm tillförd ström поглощаемая мощность 电源电流	НАПРЯЖЕНИЕ ЭЛЕКТРОПИТАНИЯ 电源电压
BL30 - BL31 - BL36 - BL37 BM69 - BM70 - BM73 - BM74 BM77 - BM78 - BM81 - BM82	0,150	34 ÷ 52
BL32 - BL33 - BL38 - BL39 BM71 - BM72 - BM75 - BM76 BM79 - BM80 - BM83 - BM84	0,310	
BL34 - BL35 - BL40 - BL41	0,445	
BJ17 - BJ20	0,297	40 ÷ 52
BJ18 - BJ21	0,545	
BJ19 - BJ22	0,600	

iGuzzini

2.516.881.02

ISO7085/03

ART	corrente assorbita (A) absorbed current courant absorbé Stromaufnahme stroomopname corriente absorbida absorberet strøm absorbert strøm tillförd ström поглощаемая мощность 电源电流	НАПРЯЖЕНИЕ ЭЛЕКТРОПИТАНИЯ 电源电压
BL30 - BL31 - BL36 - BL37 BM69 - BM70 - BM73 - BM74 BM77 - BM78 - BM81 - BM82	0,150	34 ÷ 52
BL32 - BL33 - BL38 - BL39 BM71 - BM72 - BM75 - BM76 BM79 - BM80 - BM83 - BM84	0,310	
BL34 - BL35 - BL40 - BL41	0,445	
BJ17 - BJ20	0,297	40 ÷ 52
BJ18 - BJ21	0,545	
BJ19 - BJ22	0,600	

I PERIODO GIORNALIERO DI ACCENSIONE AMMESSO

iGuzzini

1.154.627.01
IS09175/01

GB ALLOWED DAILY OPERATION PERIOD

F DURÉE QUOTIDIENNE D'ALLUMAGE ADMISSIBLE

D ERLAUBTE TÄGLICHE EINSCHALTDAUER

NL DAGELIJKSE ONTSTEKINGSPERIODE TOEGESTAAN

E PERIODO DIARIO DE ENCENDIDO PERMITIDO

DK TILLADT TIDSRUM FOR DAGLIG TÆNDING

N TILLÄTT TENNINGSTID PR. DAG

S TILLÄTEN DAGLIG PERIOD SOM PRODUKTEN KAN VARA TÄND

RUS ЕЖЕДНЕВНАЯ ДОПУСТИМАЯ ПРОДОЛЖИТЕЛЬНОСТЬ РАБОТЫ

CN 允许的 日常运营周期

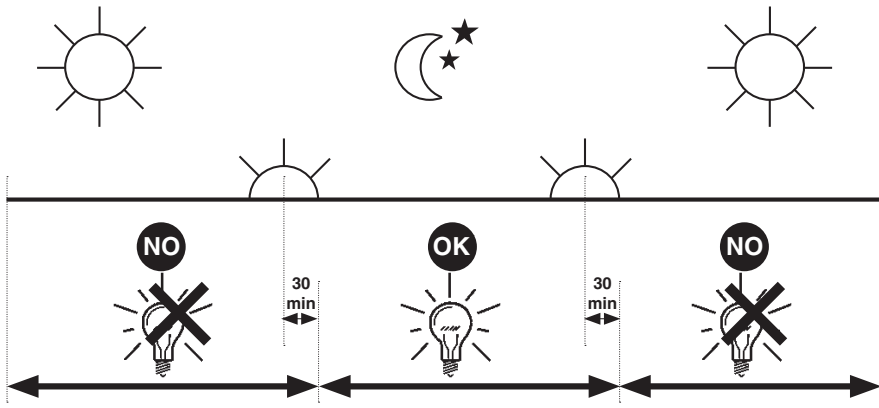

I PERIODO GIORNALIERO DI ACCENSIONE AMMESSO

iGuzzini

1.154.627.01
IS09175/01

GB ALLOWED DAILY OPERATION PERIOD

F DURÉE QUOTIDIENNE D'ALLUMAGE ADMISSIBLE

D ERLAUBTE TÄGLICHE EINSCHALTDAUER

NL DAGELIJKSE ONTSTEKINGSPERIODE TOEGESTAAN

E PERIODO DIARIO DE ENCENDIDO PERMITIDO

DK TILLADT TIDSRUM FOR DAGLIG TÆNDING

N TILLÄTT TENNINGSTID PR. DAG

S TILLÄTEN DAGLIG PERIOD SOM PRODUKTEN KAN VARA TÄND

RUS ЕЖЕДНЕВНАЯ ДОПУСТИМАЯ ПРОДОЛЖИТЕЛЬНОСТЬ РАБОТЫ

CN 允许的 日常运营周期

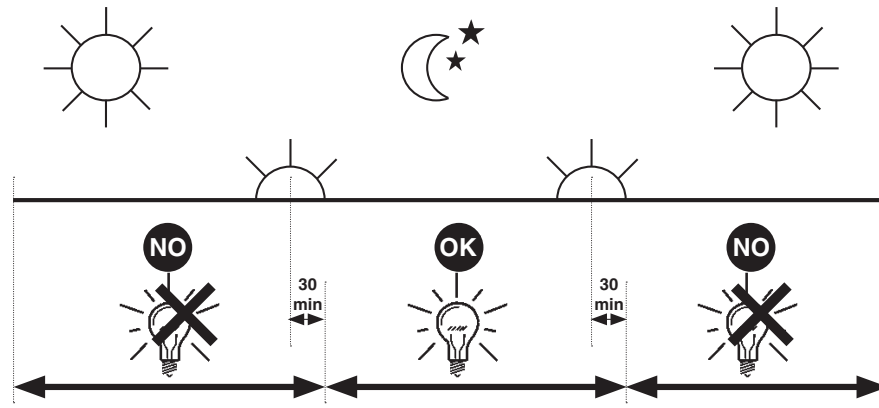

I PERIODO GIORNALIERO DI ACCENSIONE AMMESSO

iGuzzini

1.154.627.01
IS09175/01

GB ALLOWED DAILY OPERATION PERIOD

F DURÉE QUOTIDIENNE D'ALLUMAGE ADMISSIBLE

D ERLAUBTE TÄGLICHE EINSCHALTDAUER

NL DAGELIJKSE ONTSTEKINGSPERIODE TOEGESTAAN

E PERIODO DIARIO DE ENCENDIDO PERMITIDO

DK TILLADT TIDSRUM FOR DAGLIG TÆNDING

N TILLÄTT TENNINGSTID PR. DAG

S TILLÄTEN DAGLIG PERIOD SOM PRODUKTEN KAN VARA TÄND

RUS ЕЖЕДНЕВНАЯ ДОПУСТИМАЯ ПРОДОЛЖИТЕЛЬНОСТЬ РАБОТЫ

CN 允许的 日常运营周期

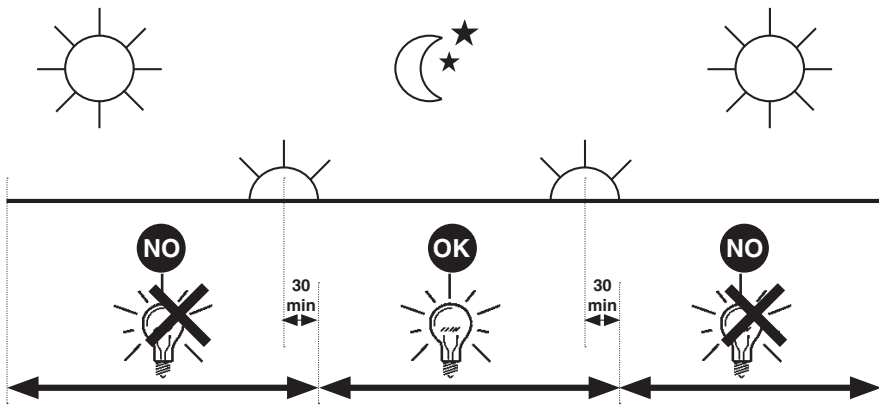

I PERIODO GIORNALIERO DI ACCENSIONE AMMESSO

iGuzzini

1.154.627.01
IS09175/01

GB ALLOWED DAILY OPERATION PERIOD

F DURÉE QUOTIDIENNE D'ALLUMAGE ADMISSIBLE

D ERLAUBTE TÄGLICHE EINSCHALTDAUER

NL DAGELIJKSE ONTSTEKINGSPERIODE TOEGESTAAN

E PERIODO DIARIO DE ENCENDIDO PERMITIDO

DK TILLADT TIDSRUM FOR DAGLIG TÆNDING

N TILLÄTT TENNINGSTID PR. DAG

S TILLÄTEN DAGLIG PERIOD SOM PRODUKTEN KAN VARA TÄND

RUS ЕЖЕДНЕВНАЯ ДОПУСТИМАЯ ПРОДОЛЖИТЕЛЬНОСТЬ РАБОТЫ

CN 允许的 日常运营周期

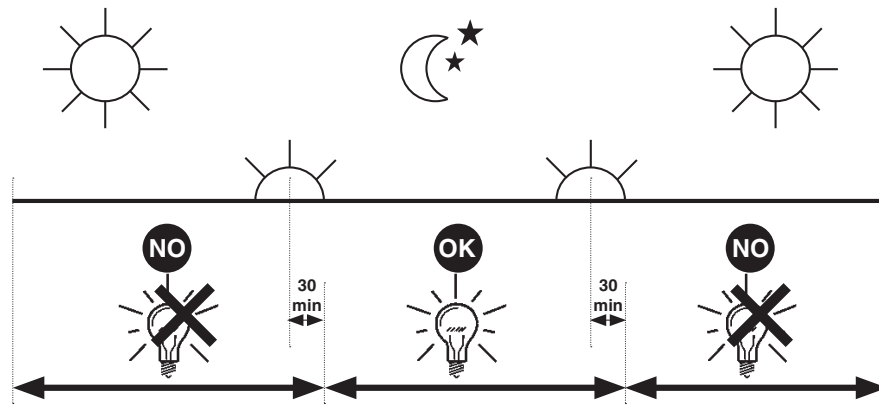

1.154.596.00
ISO6196/01

iGuzzini

I NON SOLLECITARE IL PRODOTTO A TORSIONE
GB DO NOT SUBMIT THE PRODUCT TO TWISTING
FR NE PAS SOUMETTRE LE PRODUIT À TORSION
DE LEUCHTE AUF KEINEN FALL IN LÄNGSRICHTUNG VERDREHEN!
NL BEWEEG HET PRODUCT NIET TERWIJL HET ONDERHEVIG IS AAN TORSIE
E NO FORZAR LA TORSIÓN DEL PRODUCTO
DK UDSÆ T IKKE PRODUKTET FOR VRIDNINGER
N IKKE UTSETT PRODUKTET FOR VRIDNING
S VRIDBELASTA INTE PRODUKTEN
RUS НЕ СКРУЧИВАТЬ ИЗДЕЛИЕ
CN 切勿使产品发生扭曲。

1.154.596.00
ISO6196/01

iGuzzini

I NON SOLLECITARE IL PRODOTTO A TORSIONE
GB DO NOT SUBMIT THE PRODUCT TO TWISTING
FR NE PAS SOUMETTRE LE PRODUIT À TORSION
DE LEUCHTE AUF KEINEN FALL IN LÄNGSRICHTUNG VERDREHEN!
NL BEWEEG HET PRODUCT NIET TERWIJL HET ONDERHEVIG IS AAN TORSIE
E NO FORZAR LA TORSIÓN DEL PRODUCTO
DK UDSÆ T IKKE PRODUKTET FOR VRIDNINGER
N IKKE UTSETT PRODUKTET FOR VRIDNING
S VRIDBELASTA INTE PRODUKTEN
RUS НЕ СКРУЧИВАТЬ ИЗДЕЛИЕ
CN 切勿使产品发生扭曲。

1.154.596.00
ISO6196/01

iGuzzini

I NON SOLLECITARE IL PRODOTTO A TORSIONE
GB DO NOT SUBMIT THE PRODUCT TO TWISTING
FR NE PAS SOUMETTRE LE PRODUIT À TORSION
DE LEUCHTE AUF KEINEN FALL IN LÄNGSRICHTUNG VERDREHEN!
NL BEWEEG HET PRODUCT NIET TERWIJL HET ONDERHEVIG IS AAN TORSIE
E NO FORZAR LA TORSIÓN DEL PRODUCTO
DK UDSÆ T IKKE PRODUKTET FOR VRIDNINGER
N IKKE UTSETT PRODUKTET FOR VRIDNING
S VRIDBELASTA INTE PRODUKTEN
RUS НЕ СКРУЧИВАТЬ ИЗДЕЛИЕ
CN 切勿使产品发生扭曲。

1.154.596.00
ISO6196/01

iGuzzini

I NON SOLLECITARE IL PRODOTTO A TORSIONE
GB DO NOT SUBMIT THE PRODUCT TO TWISTING
FR NE PAS SOUMETTRE LE PRODUIT À TORSION
DE LEUCHTE AUF KEINEN FALL IN LÄNGSRICHTUNG VERDREHEN!
NL BEWEEG HET PRODUCT NIET TERWIJL HET ONDERHEVIG IS AAN TORSIE
E NO FORZAR LA TORSIÓN DEL PRODUCTO
DK UDSÆ T IKKE PRODUKTET FOR VRIDNINGER
N IKKE UTSETT PRODUKTET FOR VRIDNING
S VRIDBELASTA INTE PRODUKTEN
RUS НЕ СКРУЧИВАТЬ ИЗДЕЛИЕ
CN 切勿使产品发生扭曲。

عر

لا تعرض المنتج للالتواء

- I NON SOLLECITARE IL PRODOTTO A TORSIONE
- GB DO NOT SUBMIT THE PRODUCT TO TWISTING
- E NO FORZAR LA TORSIÓN DEL PRODUCTO

2.509.257.00
IS06811/00

عر

لا تعرض المنتج للالتواء

- I NON SOLLECITARE IL PRODOTTO A TORSIONE
- GB DO NOT SUBMIT THE PRODUCT TO TWISTING
- E NO FORZAR LA TORSIÓN DEL PRODUCTO

2.509.257.00
IS06811/00

عر

لا تعرض المنتج للالتواء

- I NON SOLLECITARE IL PRODOTTO A TORSIONE
- GB DO NOT SUBMIT THE PRODUCT TO TWISTING
- E NO FORZAR LA TORSIÓN DEL PRODUCTO

2.509.257.00
IS06811/00

عر

لا تعرض المنتج للالتواء

- I NON SOLLECITARE IL PRODOTTO A TORSIONE
- GB DO NOT SUBMIT THE PRODUCT TO TWISTING
- E NO FORZAR LA TORSIÓN DEL PRODUCTO

2.509.257.00
IS06811/00

عر

لا تعرض المنتج للالتواء

- I NON SOLLECITARE IL PRODOTTO A TORSIONE
- GB DO NOT SUBMIT THE PRODUCT TO TWISTING
- E NO FORZAR LA TORSIÓN DEL PRODUCTO

عر

منتج للالتواء

- I NON SOLLECITARE IL PRODOTTO
- GB DO NOT SUBMIT THE PRODUCT
- E NO FORZAR LA TORSIÓN DEL PR

2.509.257.00
IS06811/00

عر

منتج للالتواء

- I NON SOLLECITARE IL PRODOTTO
- GB DO NOT SUBMIT THE PRODUCT
- E NO FORZAR LA TORSIÓN DEL PR

2.509.257.00
IS06811/00

عر

منتج للالتواء

- I NON SOLLECITARE IL PRODOTTO
- GB DO NOT SUBMIT THE PRODUCT
- E NO FORZAR LA TORSIÓN DEL PR

2.509.257.00
IS06811/00

عر

منتج للالتواء

- I NON SOLLECITARE IL PRODOTTO
- GB DO NOT SUBMIT THE PRODUCT
- E NO FORZAR LA TORSIÓN DEL PR

2.509.257.00
IS06811/00

عر

منتج للالتواء

- I NON SOLLECITARE IL PRODOTTO
- GB DO NOT SUBMIT THE PRODUCT
- E NO FORZAR LA TORSIÓN DEL PR

iGuzzini

2.509.386.00
ISO9176/01

الفترة الزمنية اليومية للتشغيل المسموح بها

- I PERIODO GIORNALIERO DI ACCENSIONE AMMESSO
- GB ALLOWED DAILY OPERATION PERIOD
- E PERIODO DIARIO DE ENCENDIDO PERMITIDO

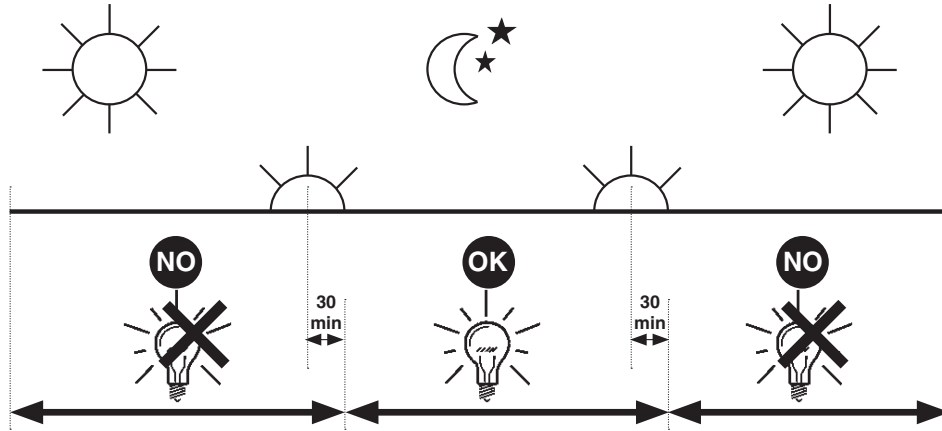

iGuzzini

2.509.386.00
ISO9176/01

الفترة الزمنية اليومية للتشغيل المسموح بها

- I PERIODO GIORNALIERO DI ACCENSIONE AMMESSO
- GB ALLOWED DAILY OPERATION PERIOD
- E PERIODO DIARIO DE ENCENDIDO PERMITIDO

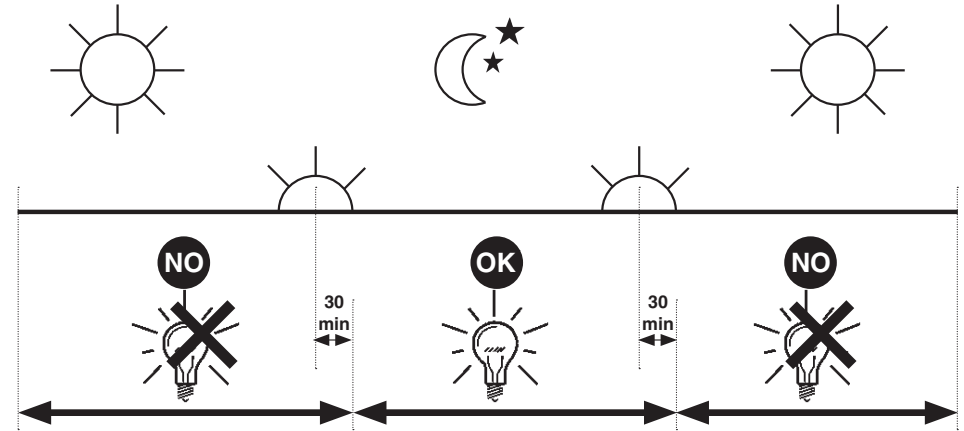

iGuzzini

2.509.386.00
ISO9176/01

الفترة الزمنية اليومية للتشغيل المسموح بها

- I PERIODO GIORNALIERO DI ACCENSIONE AMMESSO
- GB ALLOWED DAILY OPERATION PERIOD
- E PERIODO DIARIO DE ENCENDIDO PERMITIDO

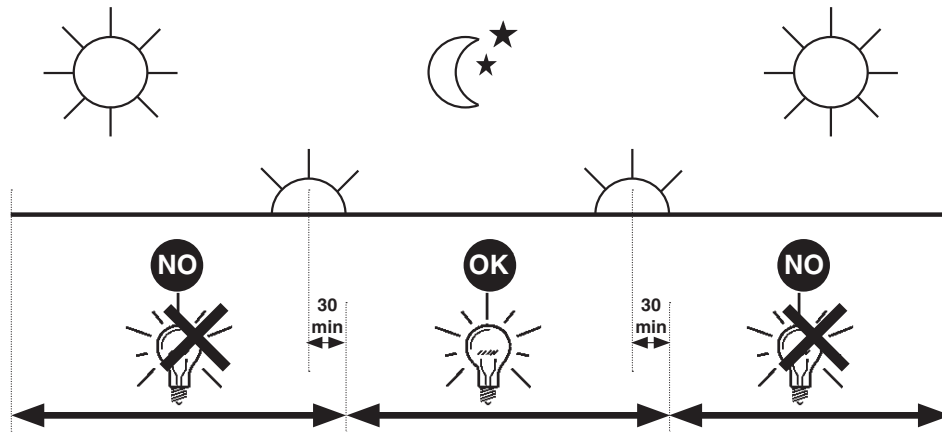

iGuzzini

2.509.386.00
ISO9176/01

الفترة الزمنية اليومية للتشغيل المسموح بها

- I PERIODO GIORNALIERO DI ACCENSIONE AMMESSO
- GB ALLOWED DAILY OPERATION PERIOD
- E PERIODO DIARIO DE ENCENDIDO PERMITIDO

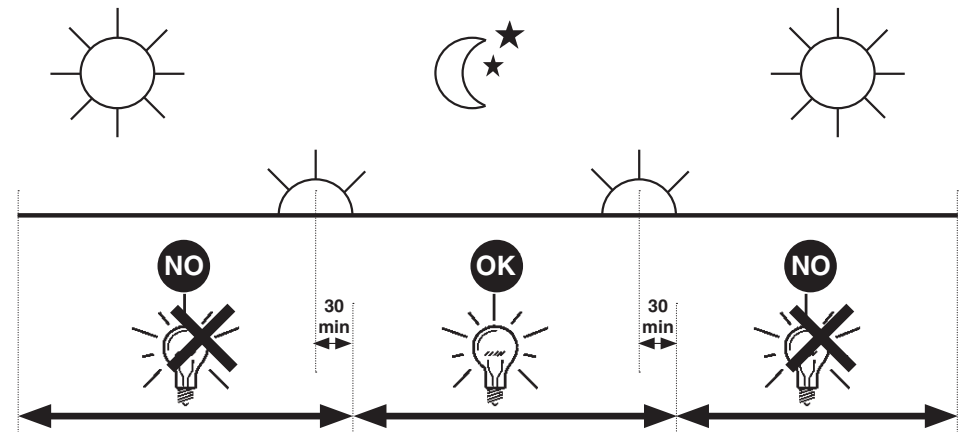

- I Istruzioni per le operazioni di servizio per l'apparecchio di illuminazione**
GB Instructions on luminaire service operations
F Instructions pour les opérations de service du luminaire
D Wartungsanleitung für die Leuchte
NL Instructies voor de onderhoudsoperaties op de verlichtingsarmatuur
E Instrucciones para las operaciones de servicio del aparato de alumbrado
DK Anvisninger i serviceindgreb på belysningsarmatur
N Anvisninger for betjening av lysapparatet
S Instruktioner för användning av belysningsanordningen
RUS Инструкция по эксплуатации осветительного прибора
CN 照明装置检修操作说明

Sostituire la lampada parzialmente esausta
 Replace the partly exhausted lamp
 Remplacer la lampe partiellement épuisée
 Die teilweise erschöpfte Lampe austauschen
 Vervang de gedeeltelijk lege lamp
 Sustituir la lámpara parzialmente agotada
 Udskift den delvist udtjente pære
 Skifte ut den delvis utbrente lyspæren
 Byt ut den delvis förbrukade lampan
 Замена частично отработанной лампочки
 更换部分老化的灯泡



Spegnimento
 Switch it off
 Extinction
 Ausschaltung
 Uitschakeling
 Apagado
 Slukning
 Slukking
 Släckning
 Выключение
 关灯

Interrompere l'alimentazione dell'apparecchio
 Cut the power supply to the luminaire
 Couper l'alimentation du luminaire
 Stromversorgung der Leuchte unterbrechen
 Onderbreek de voeding van het apparaat
 Interrumpir la alimentación del aparato
 Afbryd armaturets strømforsyning
 Avbryt strømtilførselen til apparatet
 Koppla från anordningens strömförsörjning
 Отключить электропитание прибора
 中断装置供电



Aprire l'apparecchio
 Open the fixture
 Ouvrir le luminaire
 Das Gerät öffnen
 Open het apparaat
 Abrir el aparato
 Åbn armaturet
 Åpne apparatet
 Öppna anordningen
 Раскрыть прибор
 打开装置



Rimuovere la lampada esausta
 Remove the exhausted lamp
 Retirer la lampe épuisée
 Die alte Lampe entnehmen
 Verwijder de lege lamp
 Quitar la lámpara agotada
 Tag den udtjente pære ud
 Fjerne den utbrente lyspæren
 Ta bort den förbrukade lampan
 Вынуть старую лампочку
 取出老化的灯泡

Portarla in un centro di riciclaggio
 Carry it to a recycling centre
 La porter dans une déchetterie pour son recyclage
 Ordnungsgemäß entsorgen
 Breng de lamp naar een recyclingcentrum
 Llevarla a un centro de reciclaje
 Aflever den på en genbrugsstation
 Lever den til en miljøstasjon
 Lämna in den till en återvinningsanläggning
 Сдать ее в пункт приема утильсырья
 将其送往回收中心



Inserire la nuova lampada
 Introduce the new lamp
 Installer la lampe neuve
 Die neue Lampe einsetzen
 Doe de nieuwe lamp op zijn plek
 Montar la nueva lámpara
 Sæt den nye pære i
 Sette i den nye pæren
 Sätt i den nya lampan
 Вставить новую лампочку
 装入新灯泡

Inserire la nuova lampada nel portalampana
 Fit the new lamp into the socket
 Installer la nouvelle lampe dans le support de lampe
 Die neue Lampe in den Sockel einsetzen
 Doe de nieuwe lamp in de lamphouder
 Montar la nueva lámpara en el portalampana
 Sæt den nye pære i fatningen
 Sette den nye pæren inn i lampeholderen
 Sätt i den nya lampan i lamphållaren
 Вставить новую лампочку в патрон
 将新灯泡插入灯泡架中



Riposizionare ottica
 Re-place the optic
 Remettre l'optique à sa place
 Die Optik wieder einsetzen
 Doe de optiek weer op zijn plaats
 Volver a montar la óptica
 Sæt den optiske enhed på plads
 Innstille linsen
 Flytta om optiken
 Отрегулировать линзы
 重新定位光头



Effettuare prova di funzionamento
 Perform operative test
 Procéder à un essai de fonctionnement
 Eine Funktionsprüfung durchführen
 Controleer de correcte werking
 Hacer una prueba de funcionamiento
 Afprøv funktionen
 Prøve om den fungerer
 Utför funktionstest
 Выполнить проверку исправности работы
 执行功能测试



I Istruzioni per la pulizia dell'apparecchio di illuminazione
GB Instructions on luminaire cleaning operations
F Instructions pour le nettoyage du luminaire
D Anweisungen zur Reinigung der Leuchte
NL Instructies voor de reiniging van de verlichtingsarmatuur
E Instrucciones para limpiar el aparato de alumbrado
DK Anvisninger i rengøring af belysningsarmaturet
N Anvisninger for rengjøring av lysapparatet
S Instruktioner för rengöring av belysningsanordningen
RUS Инструкции по чистке осветительного прибора
CN 照明装置清洁说明

Pulire l'apparecchio
 Clean the fixture
Nettoyer le luminaire
 Das Gerät reinigen
Reinig het apparaat
 Limpiar el aparato
Rengør armaturet
Rengjøre apparatet
Rengör anordningen
 Чистка прибора
 清洁装置



Spegnimento
 Switch it off
Extinction
Ausschaltung
Uitschakeling
Apagado
Slukning
Slukking
Släckning
Выключение
 关灯

Interrompere l'alimentazione dell'apparecchio
 Cut the power supply to the luminaire
 Couper l'alimentation du luminaire
 Stromversorgung der Leuchte unterbrechen
 Onderbreek de voeding van het apparaat
 Interrumpir la alimentación del aparato
 Afbryd armaturets strømforsyning
 Avbryt strømtilførselen til apparatet
 Koppla från anordningens strömförsörjning
 Отключить электропитание прибора
 中断装置供电



Spolverare l'ottica esterna
 Remove dust from the external optic
Dépoussiérer l'optique extérieure
Die externe Optik abstauben
Stof de externe optiek af
Quitar el polvo de la óptica exterior
Tør støvet af den udvendige optiske enhed
Fjerne støv fra den eksterne lysenheten
Damma av den yttre optiken
Вытереть пыль с внешней стороны линз
 为外侧光头掸尘



Lavare l'ottica esterna
 Wash the external optic
Laver l'optique extérieure
Die externe Optik waschen
Was de externe optiek
Lavar la óptica exterior
Vask den udvendige optiske enhed
Vaske den eksterne lysenheten
Rengör den yttre optiken
Вымыть линзы с внешней стороны
 清洁外光头



Rimuovere l'ottica
 Remove the optic
Retirer l'optique
Die Optik abnehmen
Verwijder de optiek
Quitar la óptica
Tag den optiske enhed af
Fjerne lysenheten
Ta bort optiken
Снять линзы
 取下光头



Pulire la parte interna dell'apparecchio di illuminazione
 Clean the inside of the fixture
Nettoyer l'intérieur du luminaire
Die Innenseite der Leuchte reinigen
Reinig de binnenzijde van de verlichtingsarmatuur
Limpiar el interior del aparato de alumbrado
Rengør belysningsarmaturets indvendige dele
Rengjøre lysapparatet innvendig
Rengör belysningsanordningen invändigt
Протереть осветительный прибор изнутри
 清洁照明装置内部



Riposizionare ottica
 Re-place the optic
Remettre l'optique à sa place
Die Optik wieder einsetzen
Doe de optiek weer op zijn plaats
Volver a montar la óptica
Sæt den optiske enhed på plads
Innstille linsen
Flytta om optiken
Отрегулировать линзы
 重新定位光头



Effettuare prova di funzionamento
 Perform operative test
Procéder à un essai de fonctionnement
Eine Funktionsprüfung durchführen
Controleer de correcte werking
Hacer una prueba de funcionamiento
Afprøv funktionen
Prøve om den fungerer
Utför funktionstest
Выполнить проверку исправности работы
 执行功能测试

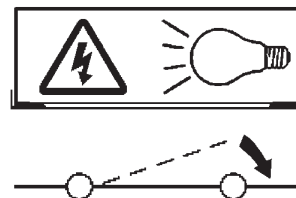

- I Istruzioni per il fine vita e lo smaltimento dei componenti**
GB Instructions on end-of-life and component disposal
F Instructions pour la gestion des composants en fin de vie et leur mise au rebut
D Anweisungen zur Entsorgung der Leuchtenkomponenten
NL Instructies voor het verwijderen van de armatuur en het recyclen van de onderdelen
E Instrucciones para el final de vida y la eliminación los componentes
DK Anvisninger i udtjent armatur og bortskaffelse af komponenter
N Anvisninger for endt levetid og avfallsbehandling av delene
S Instruktionser vid bortskaffning och kassering av komponenter
RUS Инструкции по утилизации прибора и его комплектующих по окончании его срока службы
CN 寿命期结束与零件废弃处置说明

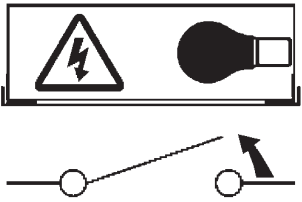
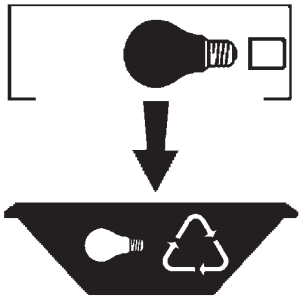
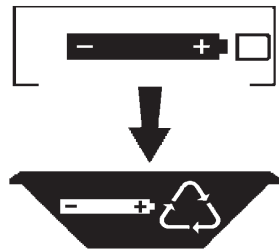
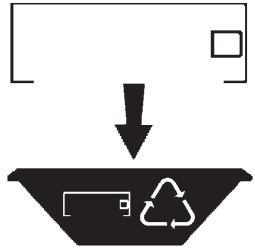
<p>Spegnimento Switch it off Extinction Ausschaltung Uitschakeling Apagado Slukning Slukking Släckning Выключение 关灯</p> <p>Interrompere l'alimentazione dell'apparecchio Cut the power supply to the luminaire Couper l'alimentation du luminaire Stromversorgung der Leuchte unterbrechen Onderbreek de voeding van het apparaat Interrompirla alimentación del aparato Afbryd armaturets strømforsyning Avbryt strømtilførselen til apparatet Koppla från anordningens strömförsörjning Отключить электропитание прибора 中断装置供电</p> 	<p>Rimuovere la/e lampada/e per la dismissione Remove the lamp(s) for decommissioning Retirer la(les) lampe(s) pour sa(leur) mise au rebut Die Lampe/n ordnungsgemäß entsorgen Verwijder de lamp(en) voor het recyclen Quitar la(s) lámpara(s) para el desecho Tag pæren/pærerne ud til bortskaffelse Fjerne lampen/-e som skal kastes Ta bort lampan/-orna för bortskaffningen Вынуть лампочку/и для утилизации прибора 取出需要丢弃的灯泡</p> 	<p>Rimuovere la batteria per la dismissione Remove the battery for decommissioning Retirer la batterie pour sa mise au rebut Die Batterie ordnungsgemäß entsorgen Verwijder de batterij voor het recyclen Quitar la batería para el desecho Tag batteriet ud til bortskaffelse Fjerne batteriet som skal kastes Ta bort batteriet för bortskaffningen Вынуть батарейку для утилизации прибора 取出需要丢弃的电池</p> 	<p>Rimuovere l'apparecchio per la dismissione Remove the fixture for decommissioning Enlever le luminaire pour sa mise au rebut Das Gerät ordnungsgemäß entsorgen Verwijder het apparaat voor het recyclen Quitar el aparato para el desecho Tag armaturet ud til bortskaffelse Fjerne apparatet som skal kastes Ta bort anordningen för bortskaffningen Снять прибор для утилизации 取出需要丢弃的装置</p> 
--	---	---	---

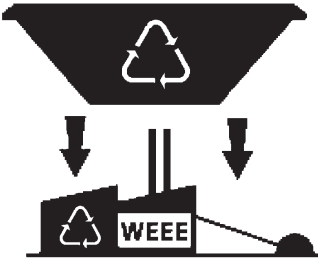
<p>Inviare i materiali ad un centro di raccolta RAEE Send the materials to a WEEE collection centre Envoyer les matériaux dans une déchetterie DEEE Die Materialien in einem WEEE-Zentrum entsorgen Zend de materialen naar een recyclingscentrum voor de AEEA Enviar los materiales a un centro de recogida RAEE Afløver materialerne på et indsamlingscenter for elektronisk udstyr Sende materialene til en miljøstasjon for resirkulering av EE-avfall Skicka materialet till en RAEE uppsamlingscentral Сдать материалы в пункт приема утильсырья 将材料送往电气和电子垃圾回收中心</p> 			
---	--	--	--