

LINEALUCE COMPACT 75 MONOCHROME - RGB RGBW - WRGBW WNC (DMX - RDM)

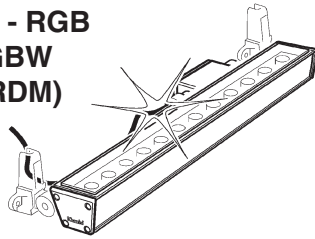

ATTENZIONE:

LA SICUREZZA DELL'APPARECCHIO E' GARANTITA SOLO CON L'USO APPROPRIATO DELLE SEGUENTI ISTRUZIONI; PERTANTO E' NECESSARIO CONSERVARLE.

WARNING:

THE SAFETY OF THIS FIXTURE IS GUARANTEED ONLY IF YOU COMPLY WITH THESE INSTRUCTIONS; REMEMBER TO CONSERVE IN A SAFE PLACE.

ATTENTION:

LA SECURITE DE L'APPAREIL N'EST GARANTIE QU'EN CAS D'UTILISATION CORRECTE DES INSTRUCTIONS SUIVANTES; IL FAUT PAR CONSEQUENT LES CONSERVER.

ACHTUNG:

DIE SICHERHEIT DES GERÄTES WIRD NUR DURCH SACHGEMÄSSE BEFOLGUNG NACHSTEHENDER ANWEISUNGEN GEWÄHRLEISTET; IHRE AUFBEWAHRUNG IST DESHALB SEHR WICHTIG.

OPGELET:

DE VEILIGHEID VAN DI ATOESTEL IS SLECHTS DAN GEGARANDEERD ALS INDIEN DE VOLGENDE INSTRUCTIES STRIKT WORDEN TOEGEPAST; DAAROM MOET MEN ZE OOK BEWAREN.

ATENCION:

LA SEGURIDAD DEL APARATO SE GARANTIZA SOLO CUMPLIENDO CUIDADOSAMENTE LAS SIGUIENTES INSTRUCCIONES; POR ELLO, ES NECESARIO CONSERVARLAS.

BEMÆRK:

SIKKERHEDEN VED BRUG AF ARMATURET KAN KUN GARANTERES, HVIS DISSE ANVISNINGER FØLGES; SØRG DERFOR FOR AT GEMME DEM.

ADVARSEL:

SIKKERHETEN I DETTE APPARATET GARANTERES KUN HVIS DU OVERHOLDER DISSE INSTRUKSJONENE; HUSK Å OPPBEVARE DEM PÅ ET TRYGT STED.

OBSERVERA!

UTRUSTNINGENS SÄKERHET KAN ENDAST GARANTERAS OM DESSA ANVISNINGAR RESPEKTERAS I DETALJ. SPARA DÄRFÖR DESSA ANVISNINGAR FÖR FRAMTIDA KONSULTATION.

ВНИМАНИЕ:

МЫ ГАРАНТИРУЕМ БЕЗОПАСНУЮ ЭКСПЛУАТАЦИЮ ИЗДЕЛИЯ ТОЛЬКО ПРИ СОБЛЮДЕНИИ СЛЕДУЮЩИХ ИНСТРУКЦИЙ; С ЭТОЙ ЦЕЛЬЮ НЕОБХОДИМО СОХРАНИТЬ ДАННУЮ БРОШЮРУ.

警告

为确保该装置安全，请遵守操作指示；并于安全场所放置。

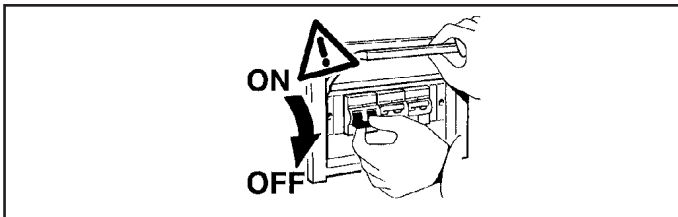

ART.	L (mm)
BN90	540
BI63 - BI64	528
BI72 - BM45 - BM66 - BP14	506
BN91	1026
BI65 - BI66	1056
BI73 - BM46 - BM67 - BP15	998
BI67 - BI68	1585
BI74 - BM47 - BM68	1490
BN92	1511

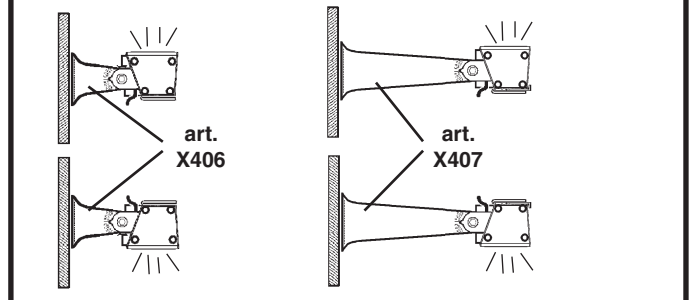
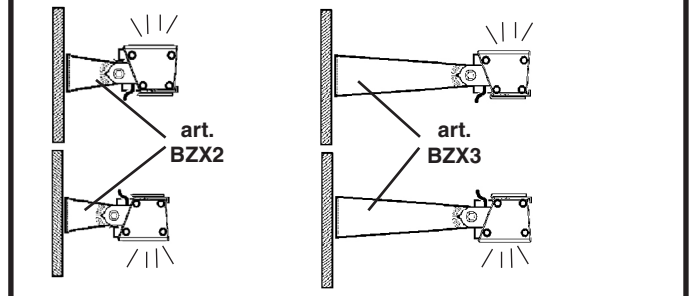
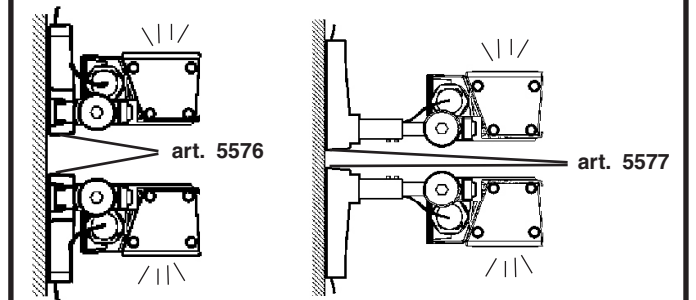
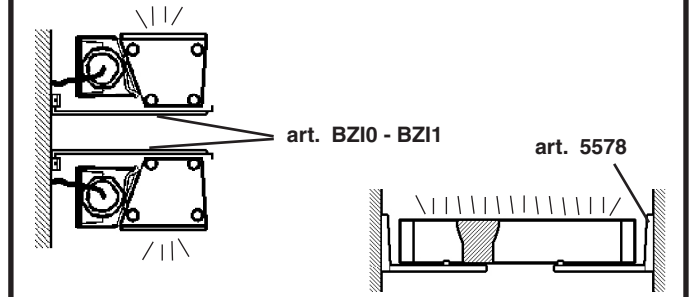
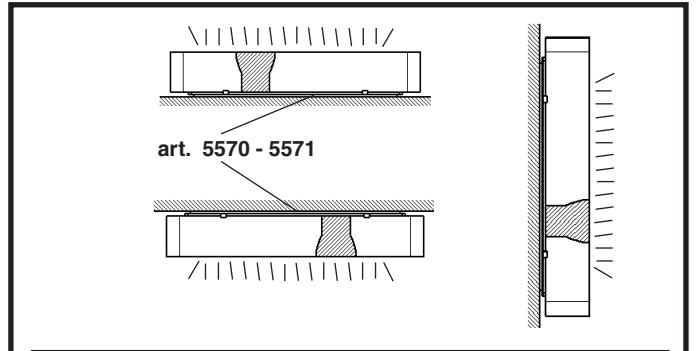
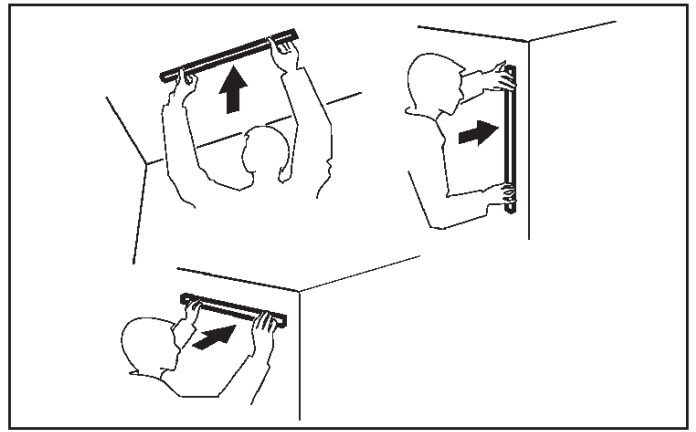

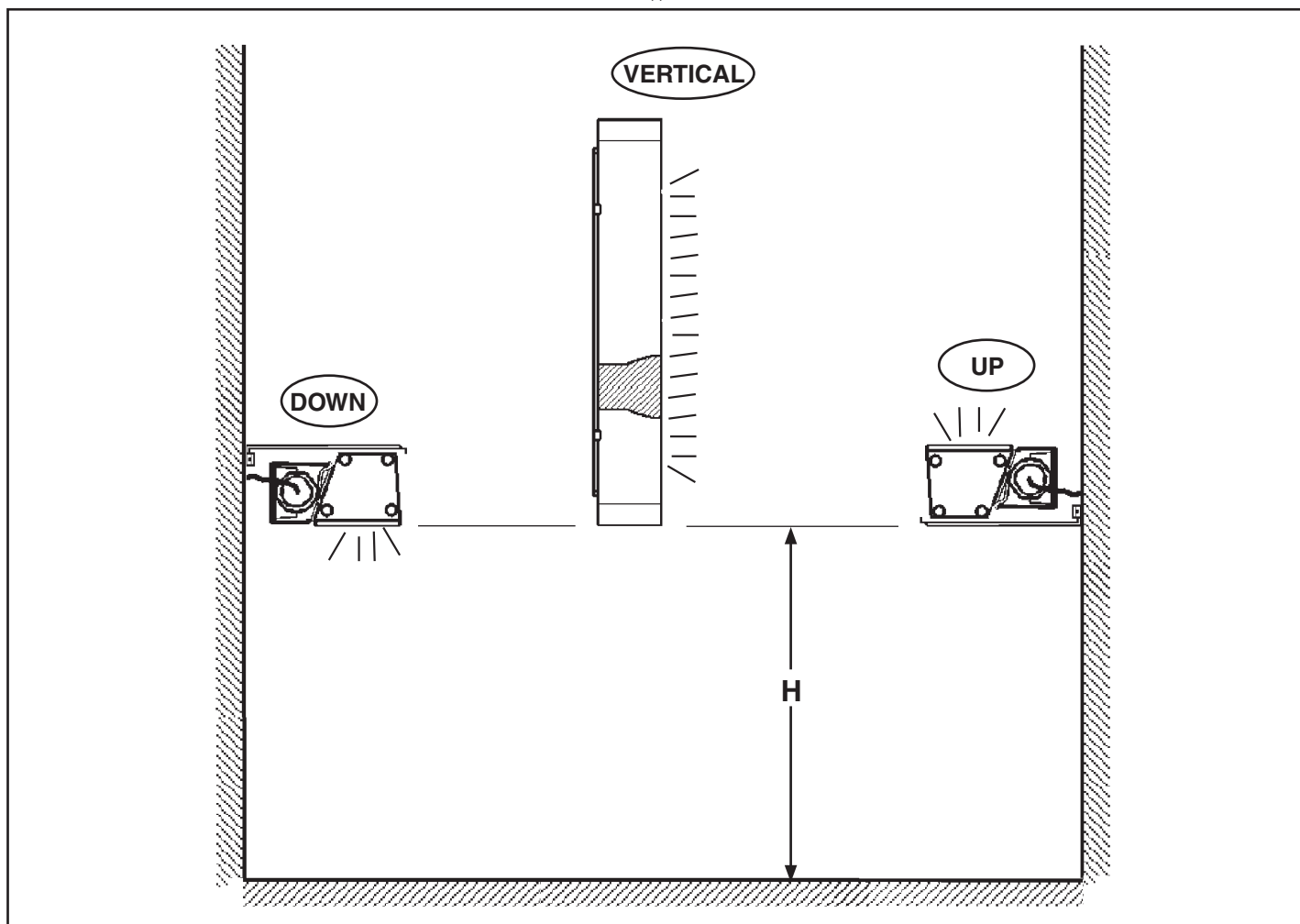

ACCESSORIES		H > 3m			H < 3m		
		UP	DOWN	VERTICAL	UP	DOWN	VERTICAL
	5570 - 5571	✓	✗	✗	✓	✓	✓
	5578	✓	✗	✗	✓	✗	✗
	BZIO - BZI1	✓	✗	✗	✓	✓	✗
	5576 - 5577	✓	✗	✗	✓	✓	✗
	BZX2 - BZX3	✓	✗	✗	✓	✓	✗
	X406 - X407	✓	✓	✗	✓	✓	✗

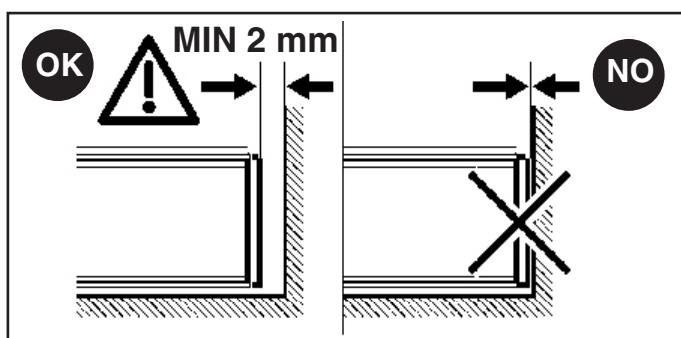
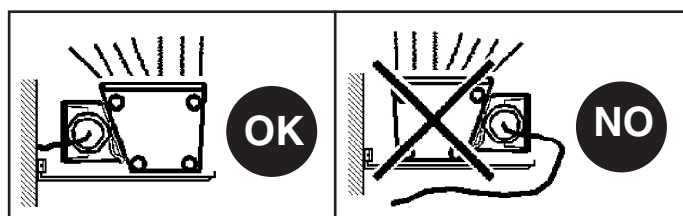
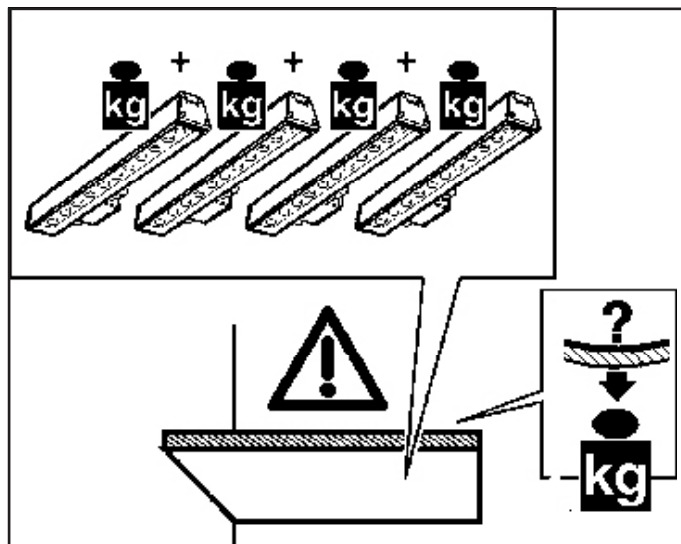
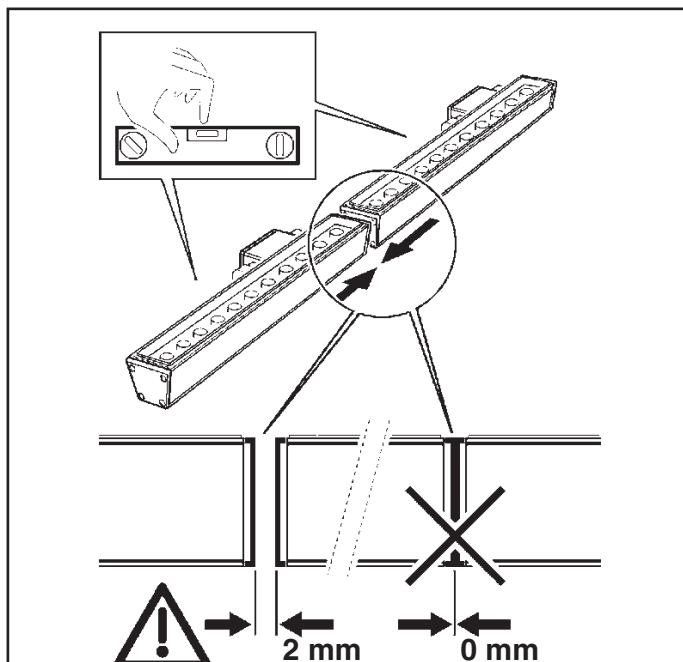

INSTALLAZIONE DEI SUPPORTI MECCANICI - INSTALLATION OF THE MECHANICAL SUPPORTS - INSTALLATION DES SUPPORTS MECANQUES
 BEFESTIGUNG DER HALTEVORRICHTUNGEN - HET INSTALLEREN VAN DE MECHANISCHE STEUNEN - INSTALACIÓN DE LOS SOPORTES MECÁNICOS
 INSTALLATION AF MEKANISKE HOLDERE - INSTALLASJON AV DE MEKANISKE STØTTENE - INSTALLATION AV METALLHÅLLARE
 МОНТАЖ МЕХАНИЧЕСКИХ КРЕПЛЕНИЙ - 机械支架的安装

TABELLA INTERASSI DI FORATURA - TABLE OF CENTRE TO CENTRE DISTANCES OF HOLLING - TABLEAU DES ESPACEMENT DE PERCEGE - TABELLE DER BOHR - MITTENABSTÄNDE
 TABEL VAN DE AFSTAND TUSSEN DE ASSEN VAN DE GATEN - TABLA INTER - EJES DE PERFORACION - TABEL OVER HULAFSTAND
 TABELL OVER AVSTANDER PÅ HULLING SENTER TIL SENTER - TABELL FÖR HÅLDELNING - ТАБЛИЦА ШАГОВ ОТВЕРСТИЙ - 面板孔的中心距离

L (mm)	ART.	BZ10 K(mm)	BZ11 K(mm)	5570 5571 K(mm)	BZX2 X406 K(mm)	5576 K(mm)	BZX2 X407 K(mm)	5577 K(mm)	BZX2-BZX3 X406-X407 5576-5577 Y(mm)	5578 K(mm)	BZV9 Y(mm)	BZW0 K(mm)
528	BI63 - BI64	240	-	265	396	440	396	440	-	-	-	-
506	BI72 - BM66	240	-	265	374	420	374	420	-	-	-	-
506	BM45	-	-	-	-	-	374	420	-	-	240	-
540	BN90	-	-	-	-	-	-	-	-	-	240	-
506	BP14	-	-	-	-	-	-	-	-	-	-	-
1056	BI65 - BI66	240	-	265	924	970	924	970	-	1106 ÷ 1386	-	-
998	BI73 - BM67	240	-	265	866	910	866	910	-	1106 ÷ 1386	-	-
998	BM46	-	-	-	-	-	-	-	-	-	240	-
1026	BN91	-	-	-	-	-	-	-	-	-	240	-
998	BP15	-	-	-	-	-	866	910	-	-	-	-
1585	BI67 - BI68	-	600	600	1453	1500	1453	1500	750	1635 ÷ 1915	-	-
1490	BI74 - BM68	-	600	600	1358	1400	1358	1400	750	1635 ÷ 1915	-	-
1490	BM47	-	-	-	-	-	-	-	750	-	-	600
1511	BN92	-	-	-	-	-	-	-	750	-	-	600

ART. 5576 - 5577 - BZX2 - BZX3 - X406 - X407

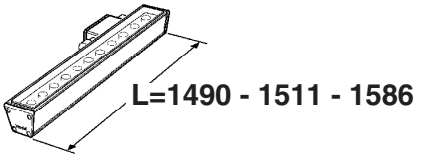

NO

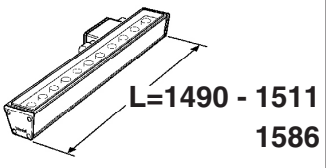
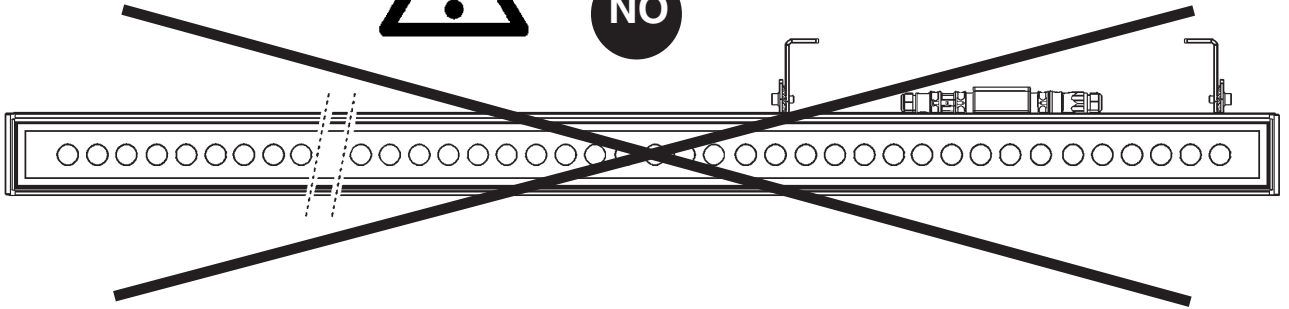

OK

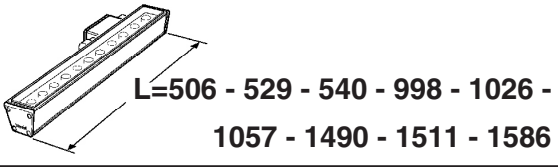
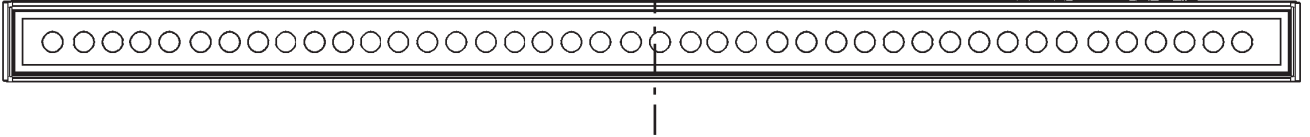
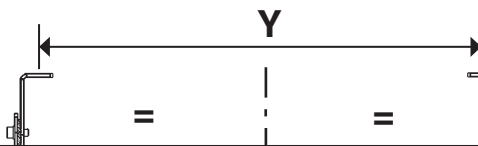

OK

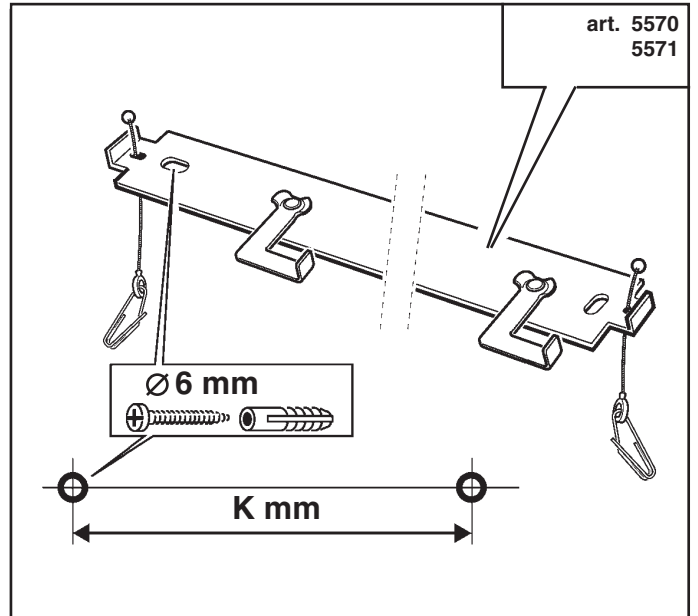
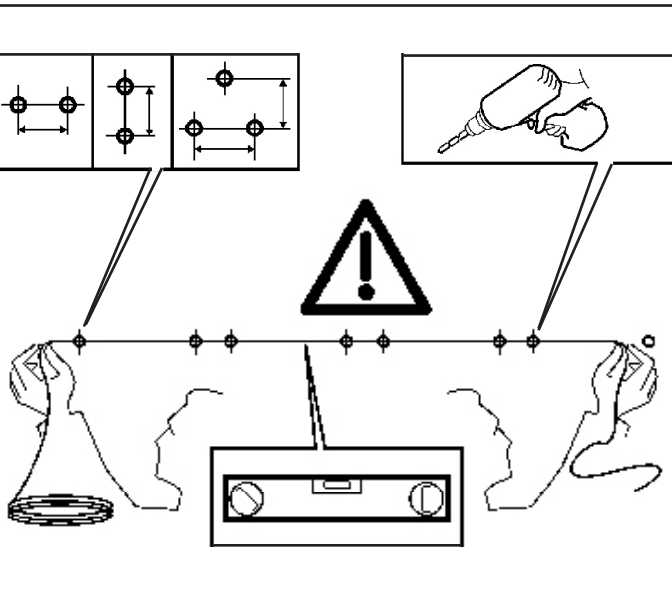
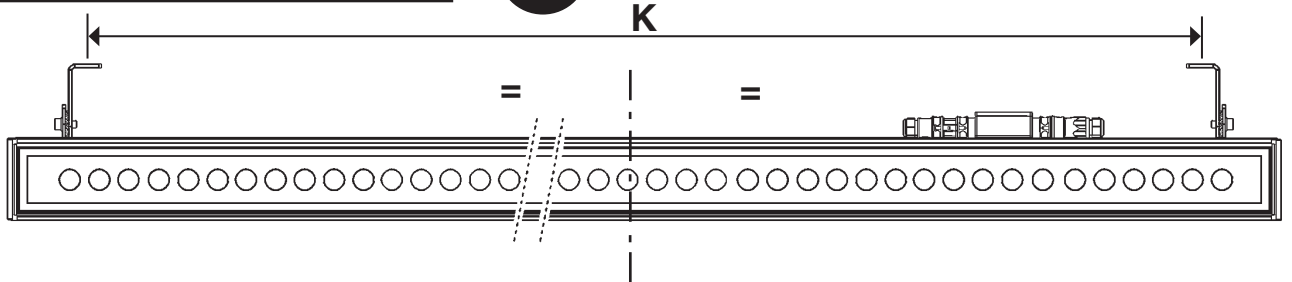

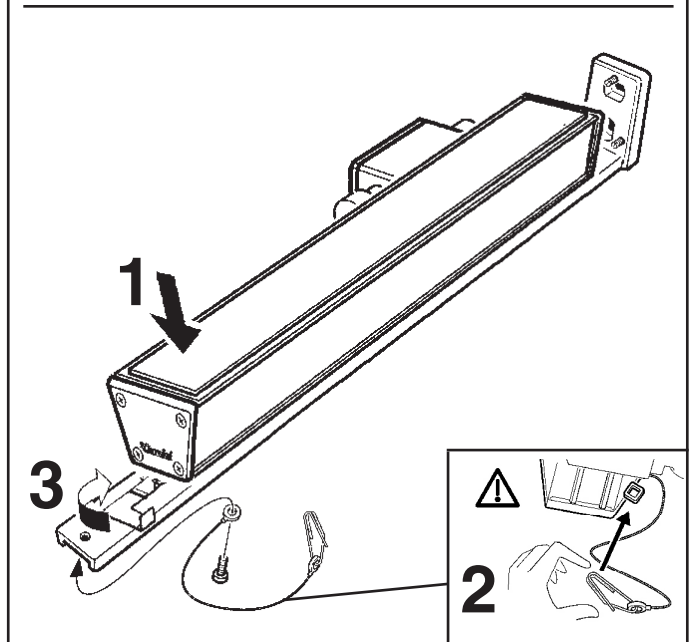
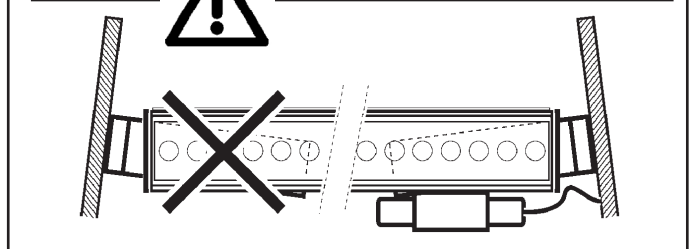
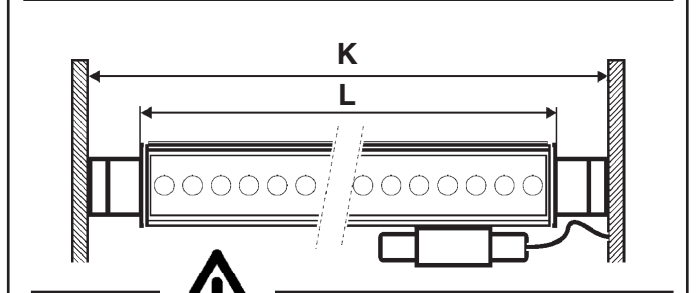
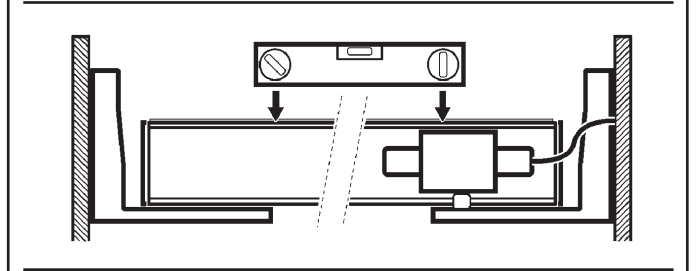
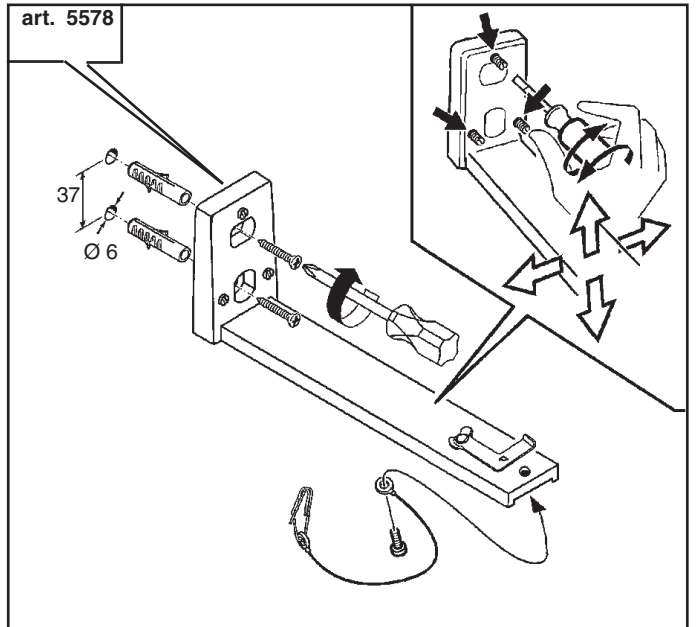
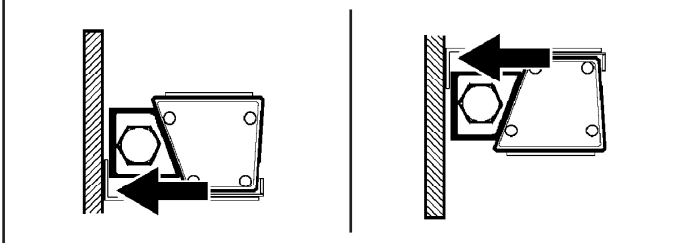
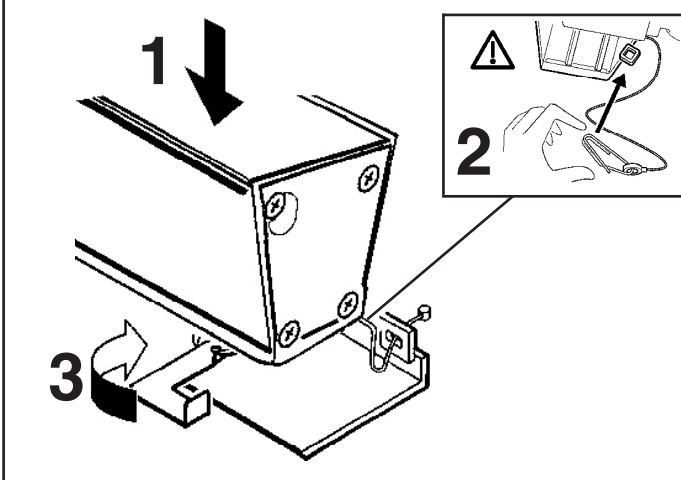
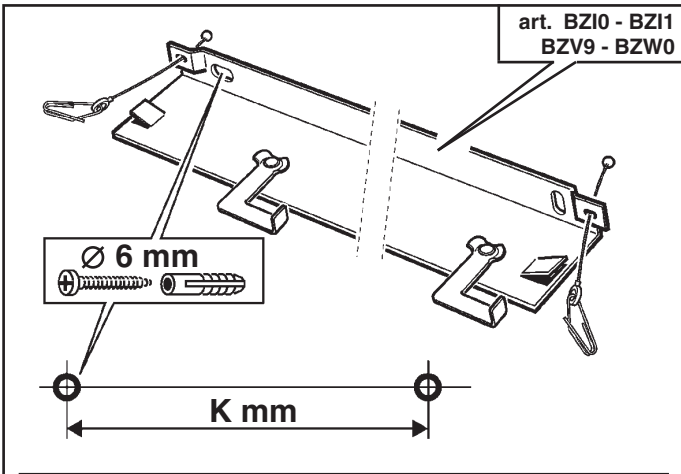
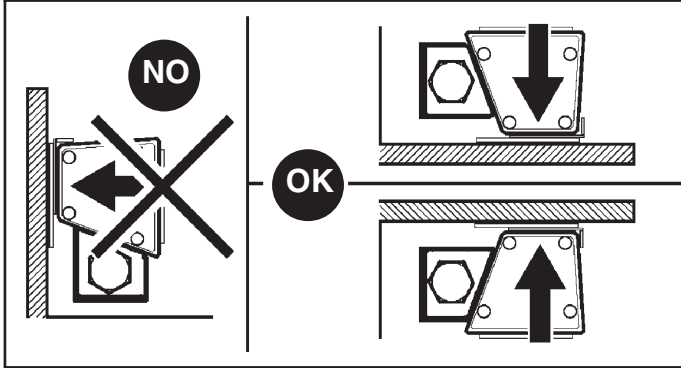
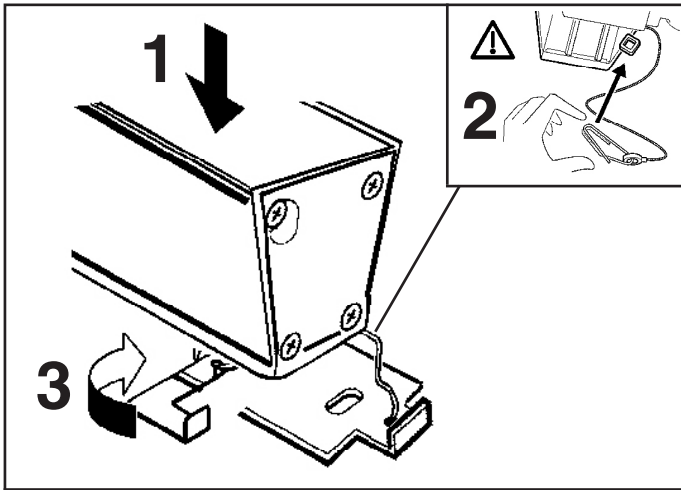

art. 5576

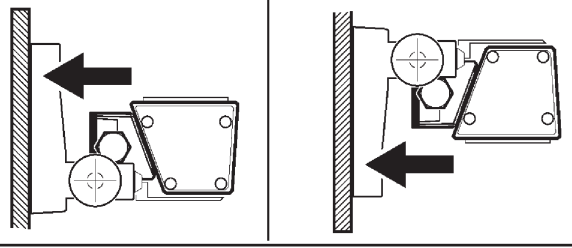
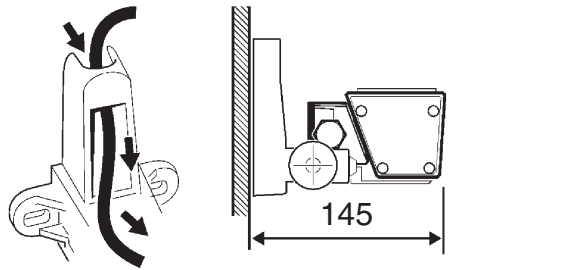
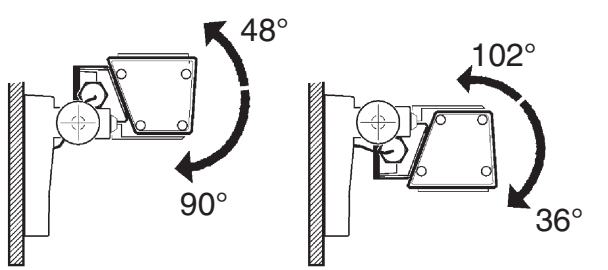
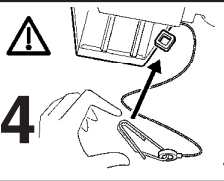
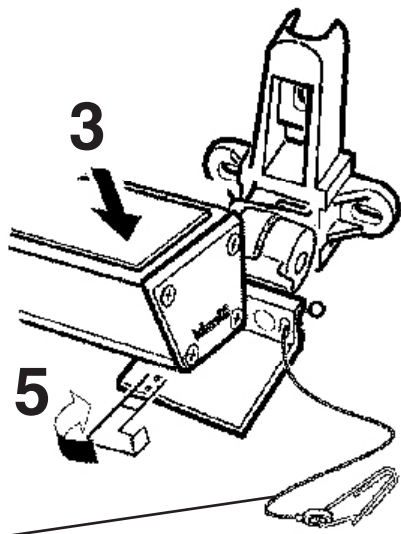
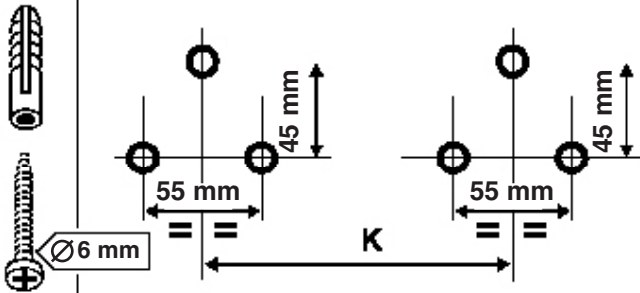
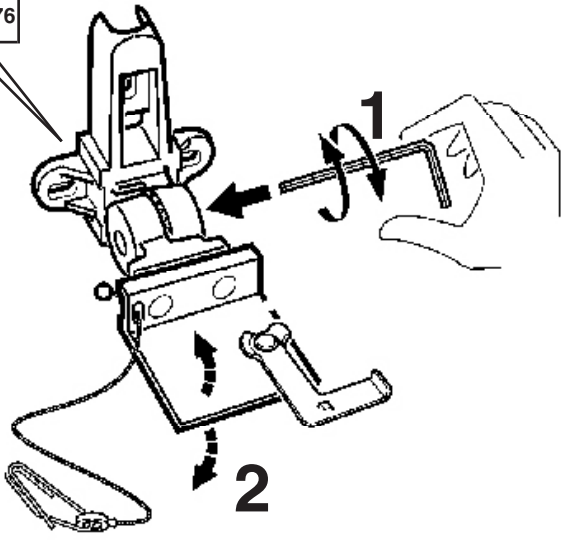

art. 5577

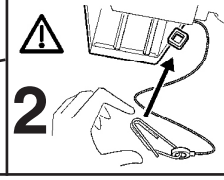
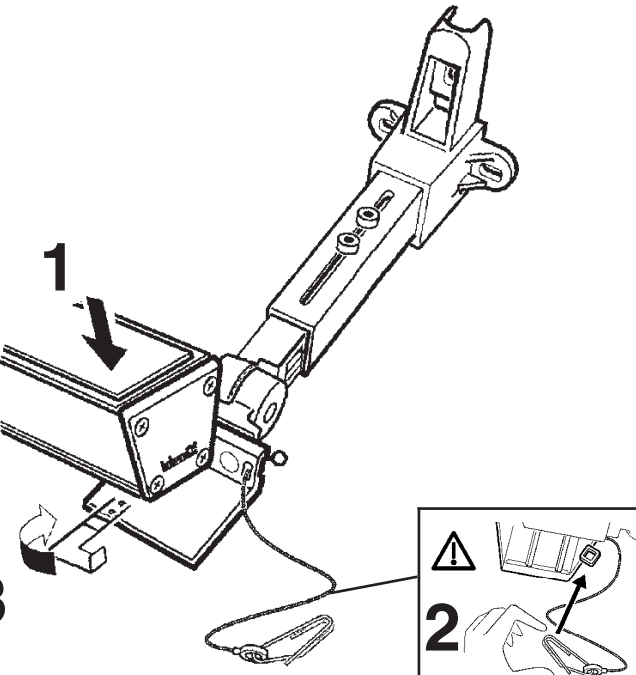
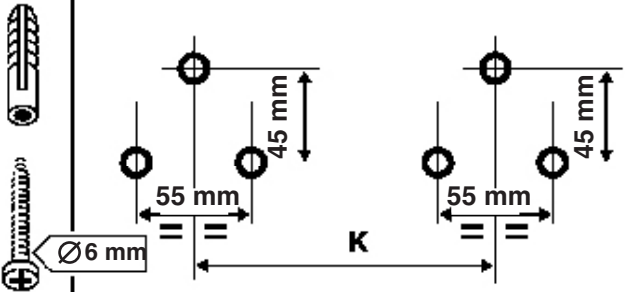
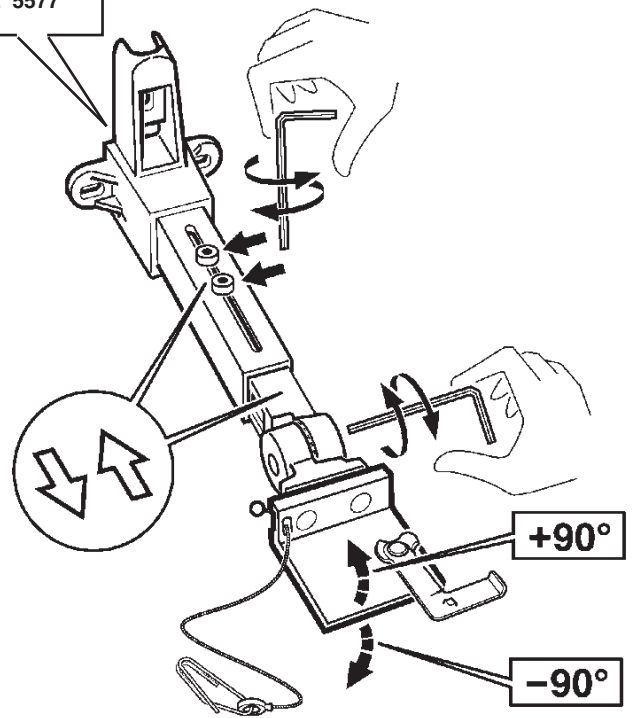

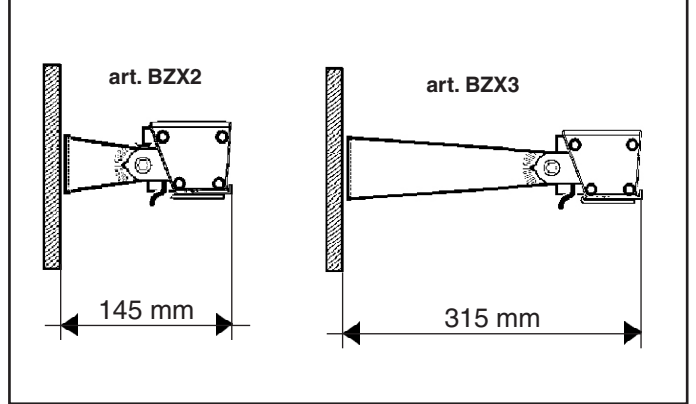
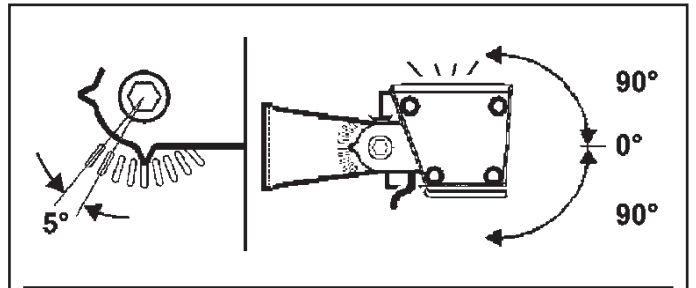
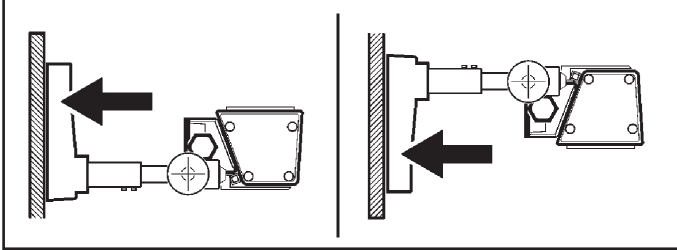
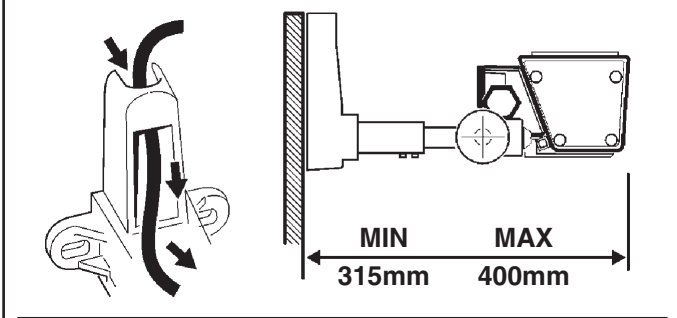
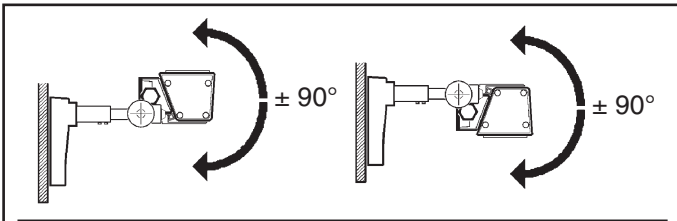

art. BZX2 - BZX3

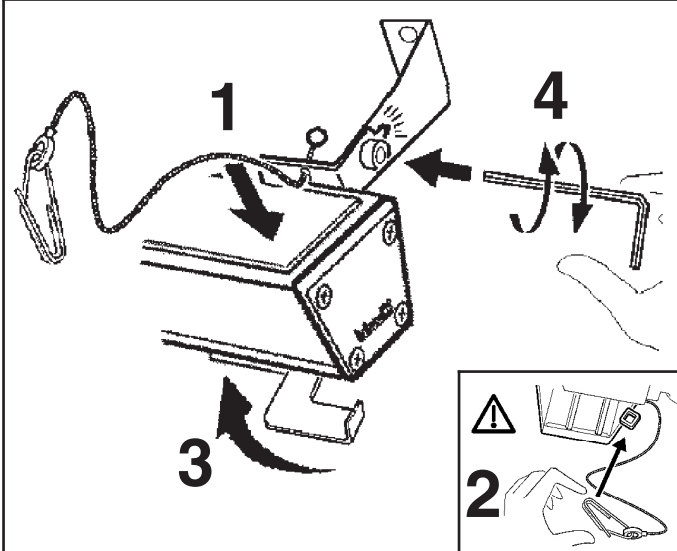
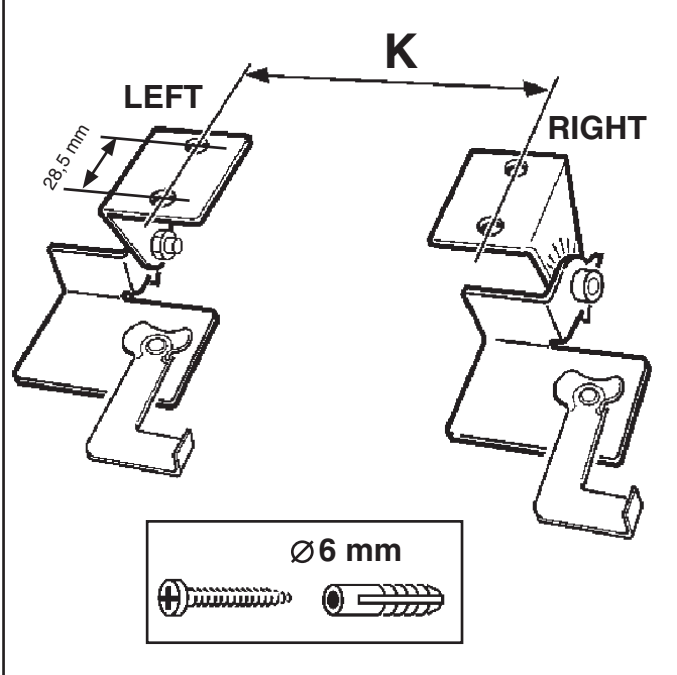

art. 5570 - 5571 - 5576 - 5577 - 5578 - BZIO
BZI1 - BZX2 - BZX3

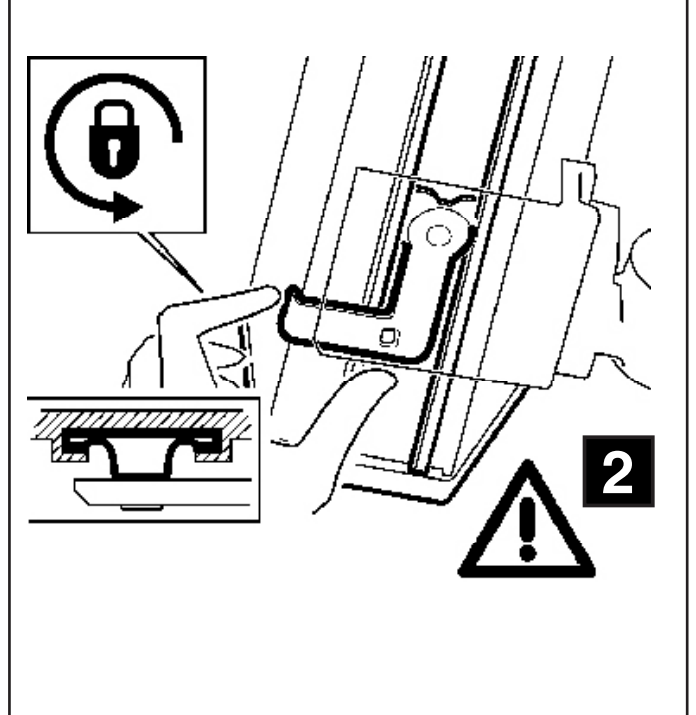
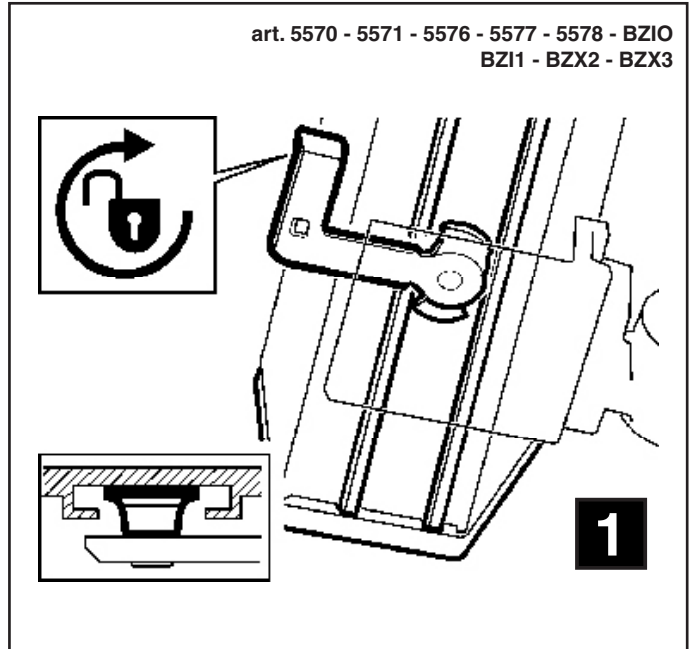

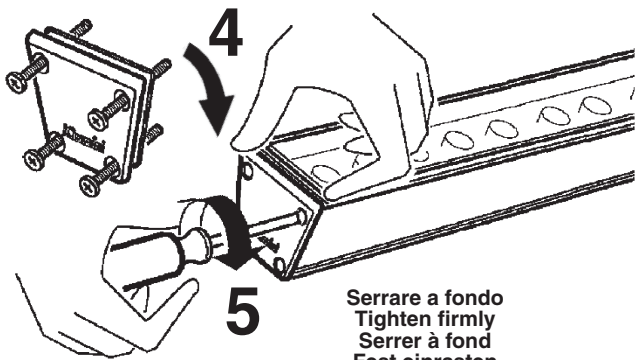
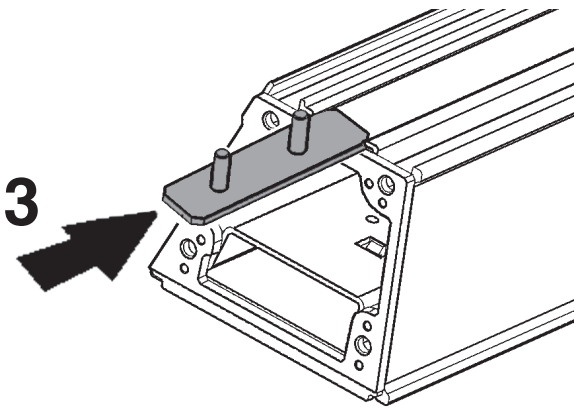
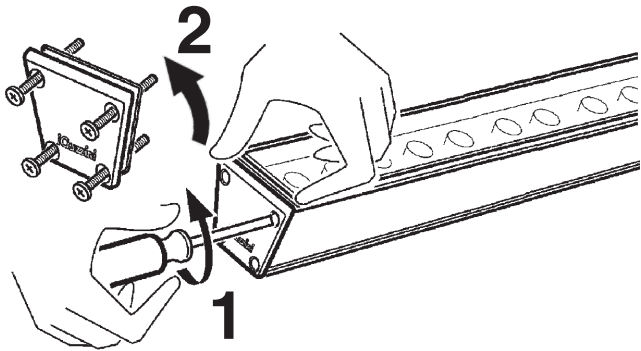
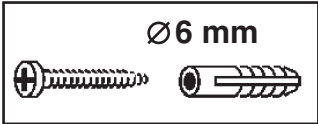
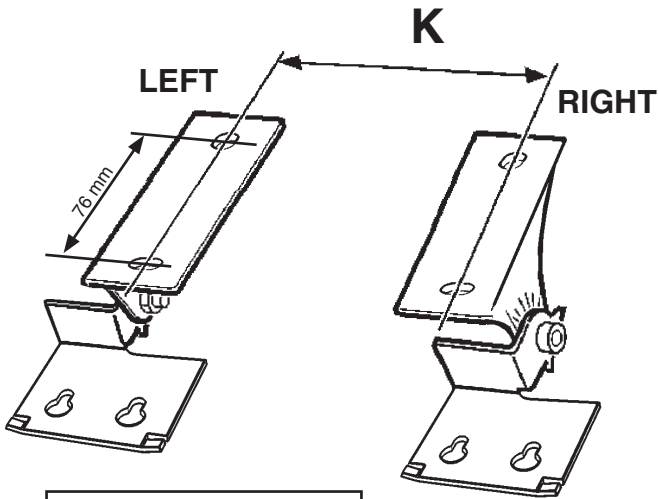

Serrare a fondo
Tighten firmly
Serrer à fond
Fest einrasten
Goed aanschroeven
Enrosca en firme
Skrues i bund
Trek til godt
Dra åt till botten
закручивать до упора
完全拧紧

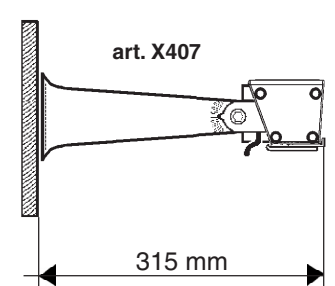
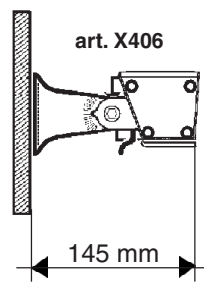
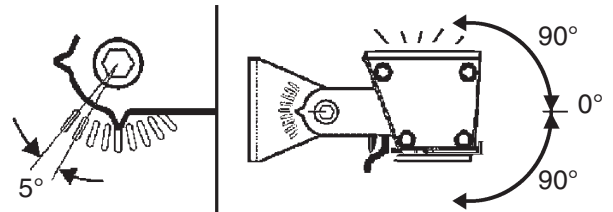
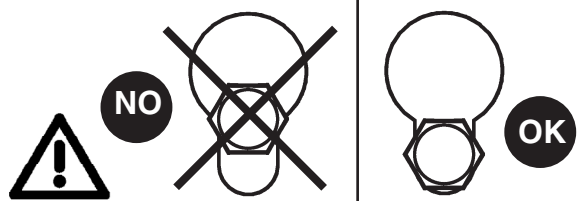
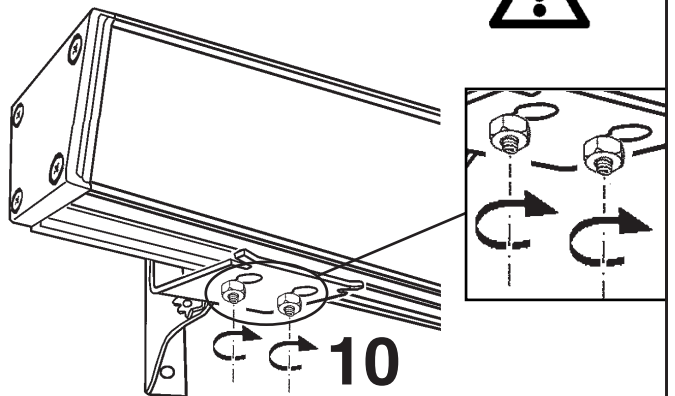
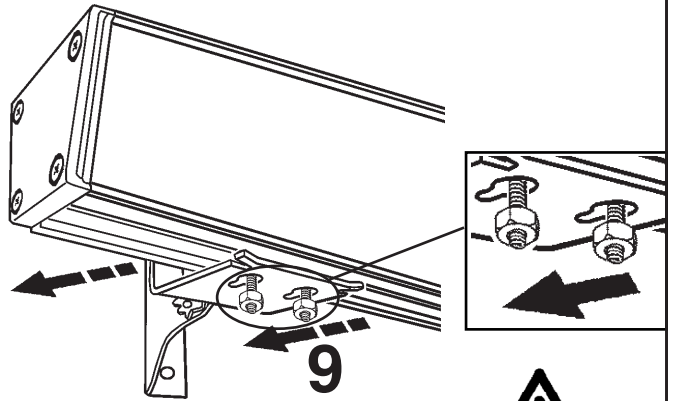
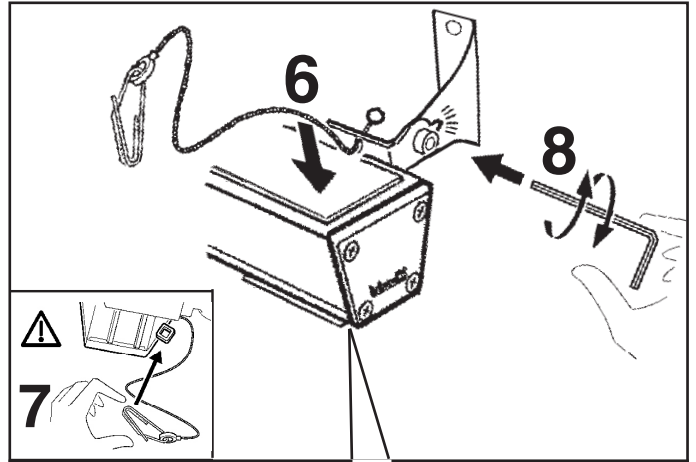

DMX

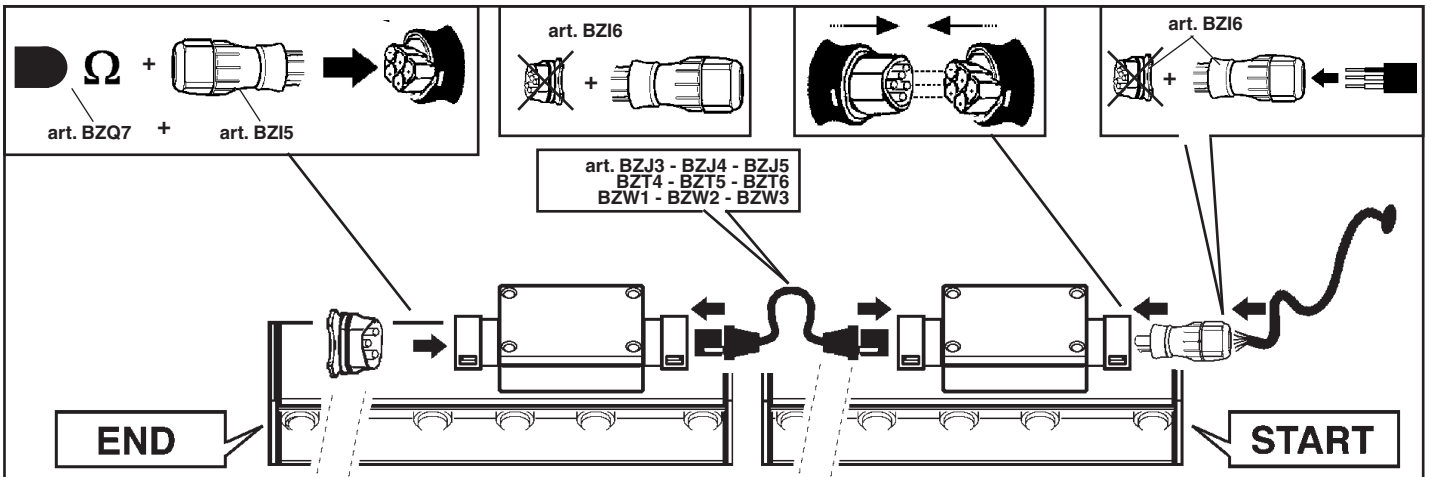
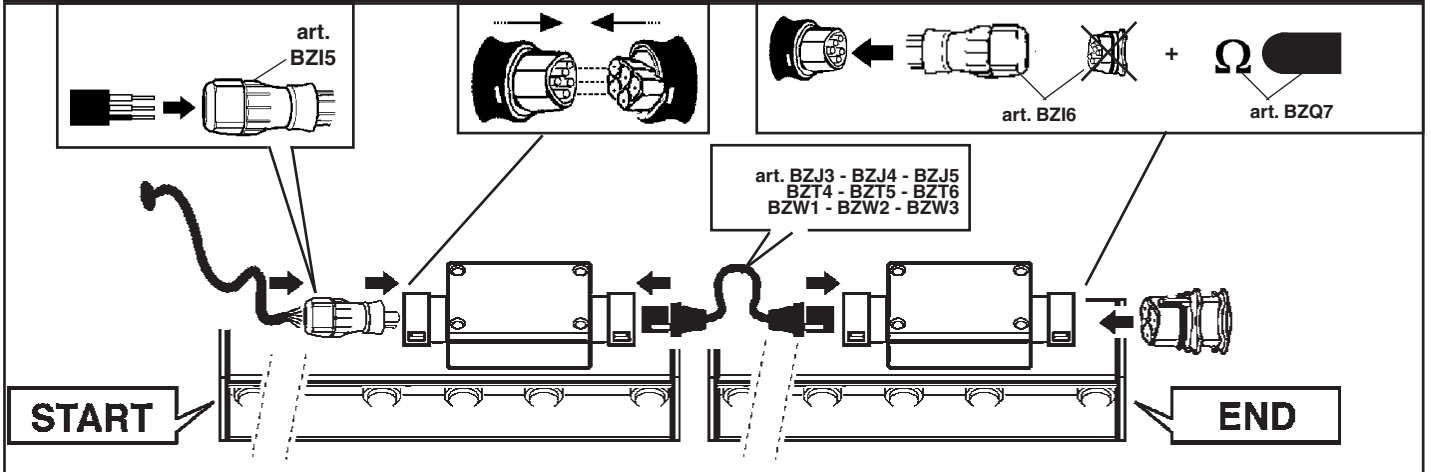
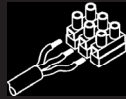

Vin = 160-305V
Vin = 127-400V

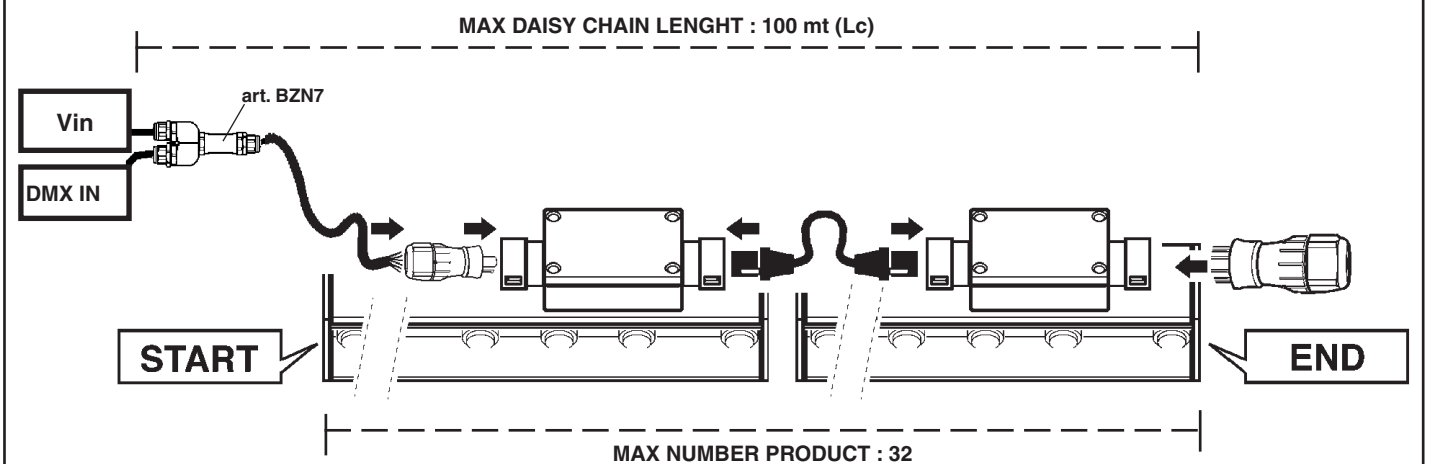

DMX DAISY CHAIN:

1. Max number products: 32
2. Max Daisy Chain Length: 100 meters (Lc)

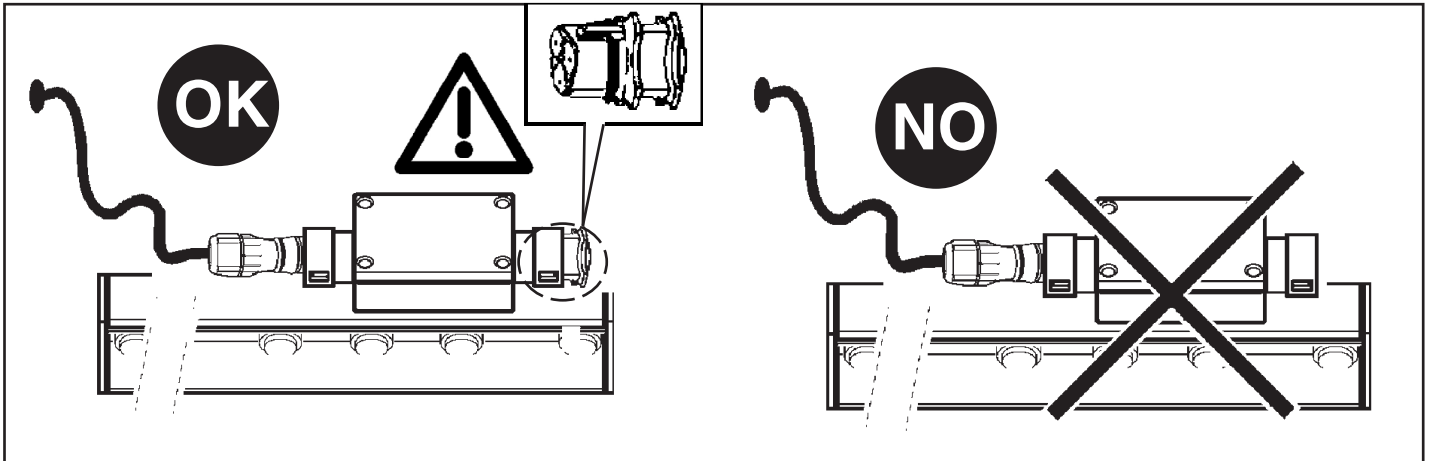
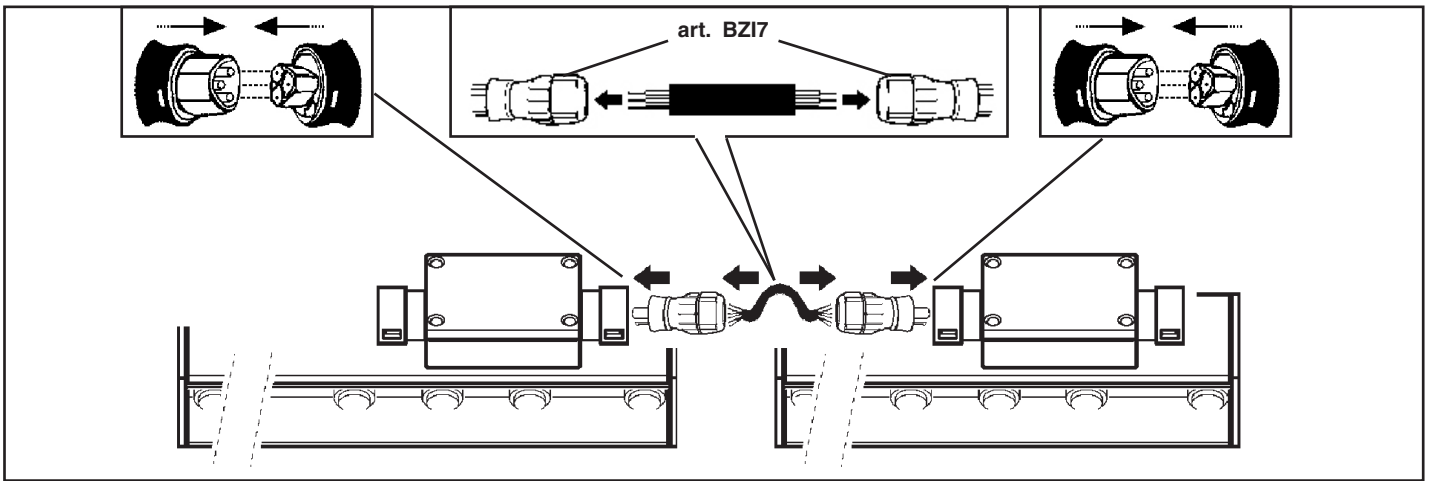

ART.	n° poli - n° poles n° pôles - n° Polen n° polen - n° polos n° polerne - n° polene n° polerna n° полюсов 芯数	cavo - cable câble - Kabel kabel - kabel ledning - kabel kabel кабель 电缆 Ø (mm)	Sezione - Section Section - Querschnitt Doorsnede - Sección Snit - Avsnitt Tvärsnitt Сечение 安装区域 (mm²)
BZI5	5	10 ÷ 14mm	1,5 ÷ 2,5 mm ²
BZI6			
BZI7			

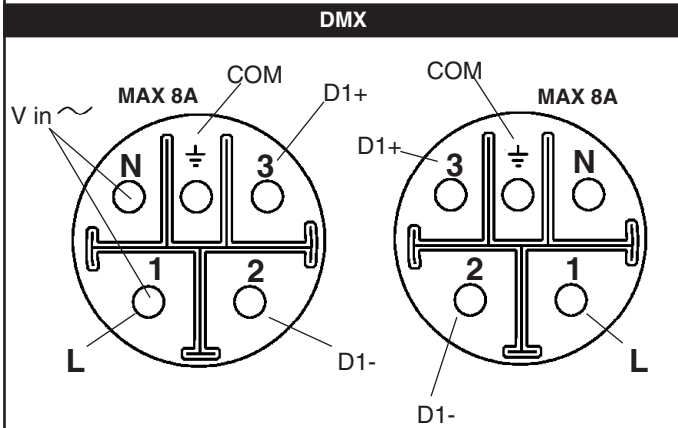
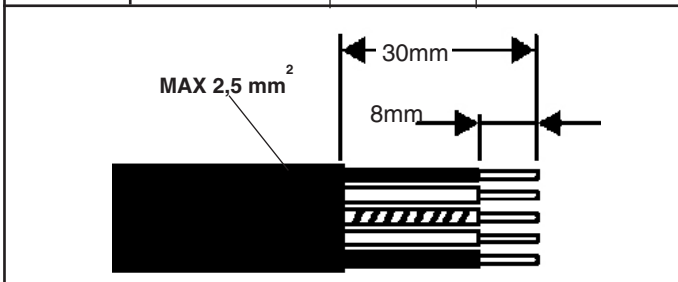

Product version	ADDRESSES n°	ADDRESSES			
		1	2	3	4
Monochrome	1	White			
WNC	3	Warm	Neutral	Cool	
RGB	3	Red	Green	Blue	
WRGB	4	Red	Green	Blue	White
WRGBW	4	Red	Green	Blue	White

!

I Prima di alimentare l'impianto assicurarsi del corretto collegamento delle polarità. Un errato collegamento può comportare il malfunzionamento dei prodotti.

GB Before powering the system, make sure polarities were properly connected. Incorrect connection may cause the product to malfunction.

F Avant de mettre l'installation sous tension, assurez-vous que la polarité de connexion est respectée. Une erreur de connexion peut entraîner le mauvais fonctionnement du produit.

D Bevor die Anlage mit Strom versorgt wird ist sicherzustellen, dass die Pole richtig angeschlossen wurden. Ein falscher Anschluss kann die Fehlfunktion der Produkte zur Folge haben.

NL Voordat u de installatie onder stroom zet dient u zich ervan te verzekeren dat de polariteiten correct zijn aangesloten. Een onjuiste aansluiting kan een verkeerde werking van de producten teweegbrengen.

E Antes de alimentar la instalación compruebe que la conexión de las polaridades sea correcta. Una conexión incorrecta puede ocasionar el malfuncionamiento de los productos.

DK Inden der sættes strøm på anlægget, skal man sikre sig, at polerne er forbundet korrekt. En forkert tilslutning kan medføre fejlfunktion på produkterne.

N Kontrollere at du har koblet med korrekt polaritet, før du kobler strømmen til anlægget. Feil tilkobling kan føre til at produktene ikke fungerer korrekt.

S Se till att anslutningens polaritet är korrekt innan anordningen strömförsörjs. S En felaktig anslutning kan leda till att produkten fungerar på ett felaktigt sätt.

RUS Перед запитыванием системы проверить правильность подсоединений полюсов. Неправильное подсоединение может привести к неисправной работе приборов.

CN 为系统供电前，请确保两极连接正确。不正确的连接可能会导致产品发生故障。

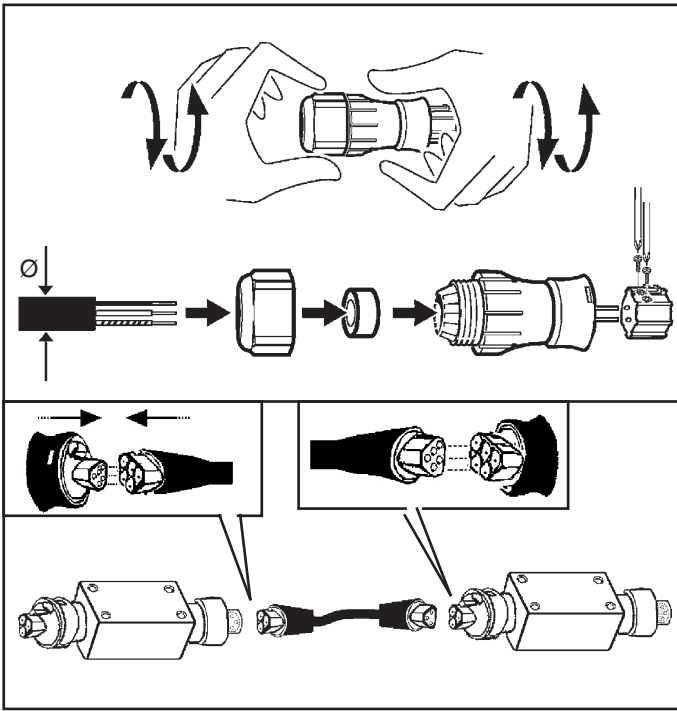

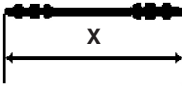
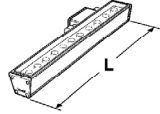
ART.	cavo - cable câble - Kabel kabel - cable ledning - kabel kabel - кабель 电缆	 (mm)	 (mm)
BZJ3		430	528
BZJ4	5 x 2,5mm ²	960	1056
BZJ5		1490	1585
BZT4		408	506
BZT5	5 x 2,5mm ²	902	998
BZT6		1395	1490
BZW1		408	540
BZW2	5 x 2,5mm ²	893	1026
BZW3		1378	1511

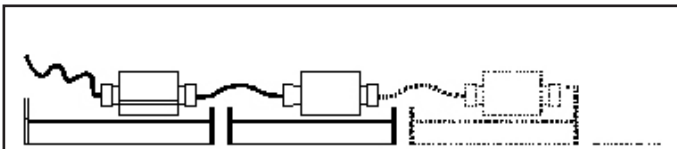

- I Calcolare il numero massimo dei prodotti collegabili in cascata, tenendo conto dell'assorbimento dei prodotti, della sezione dei cavi, della lunghezza dei cavi e della corrente max dei connettori (8A) .
- GB Calculate the maximum number of products connectable in cascade based on products' consumption, connectors' maximum current, cables' section and length (8A) .
- F Calculer le nombre maximum de produits raccordables en cascade en tenant compte de la puissance absorbée par les luminaires, de la section et de la longueur des câbles ainsi que du courant maximum des connecteurs (8A) .
- D Die maximale Anzahl der in Kaskadenschaltung anschließbaren Produkte unter Berücksichtigung der Leistungsaufnahme der Produkte, Kabeldurchmesser und -länge sowie des max. Stroms der Verbinder berechnen (8A) .
- NL Bereken het maximale aantal producten dat in cascadevolgorde kan worden aangesloten. Houd rekening met de stroomopnamen van de producten, van de kabeldiameter, de lengte van de kabels en van de max stroom van de connectoren (8A) .
- E Calcular el número máximo de productos conectables en cascada, teniendo en cuenta la absorción de los productos, la sección de los cables, la longitud de los cables y la corriente máxima de los conectores (8A) .
- DK Beregn det maksimale antal produkter, der kan tilsluttes på række, idet der tages højde for produkternes strømforbrug, kablernes tværsnit og længde samt stikkens maksimale strømstyrke (8A) .
- N Beregn maksimalt antal produkter som kan kaskadekobles. Ta med i betraktningen produktens strømoptak, ledningens tværsnit og længde, samt koblingsstykkens toppstrøm (8A) .
- S Beräkna max. antal produkter som kan kaskadkopplas genom att ta hänsyn till produkternas strömförbrukning, kablarnas tvärsnitt och längd, samt kontakternas max. ström (8A) .
- RUS Рассчитать максимальное число последовательно подсоединяемых изделий, учитывая поглощение изделий, сечение и длину проводов и макс. ток разъемов (8A) .
- CN 根据产品的能耗、连接端的最大电流、电线的截面大小和长度，计算出可并列连接的最多产品数 (8A) .

- I N.B.: Per chiudere la linea DMX inserire sull'ultimo modulo l'art. BZQ7.
- GB N.B.: To close the DMX line, add item BZQ7 onto the last module.
- F N.B.: Pour fermer la ligne DMX, saisir l'article BZQ7 dans le dernier module.
- D N.B.: Zum Schließen der DMX-Linie am letzten Modul den Artikel BZQ7 einsetzen.
- NL N.B.: Teneinde de DMX lijn af te sluiten, dient u op de laatste module het artikel BZQ7 in te voeren.
- E Nota: Para cerrar la línea DMX introducir en el último módulo el art. BZQ7.
- DK N.B.: For at lukke DMX-linjen skal man installere art. BZQ7 på sidste modul.
- N NB! For å lukke DMX-linjen må du sette art. BZQ7 på den siste modulen.
- S OBS! För att avsluta DMX-linjen, sätt in art. BZQ7 på sista modulen.
- RUS ПРИМЕЧАНИЕ: Для замыкания линии DMX установите на последний модуль арт. BZQ7.
- CN 注意: 如要关闭 DMX 线, 请将部件 BZQ7 加入到最后一个模块中。

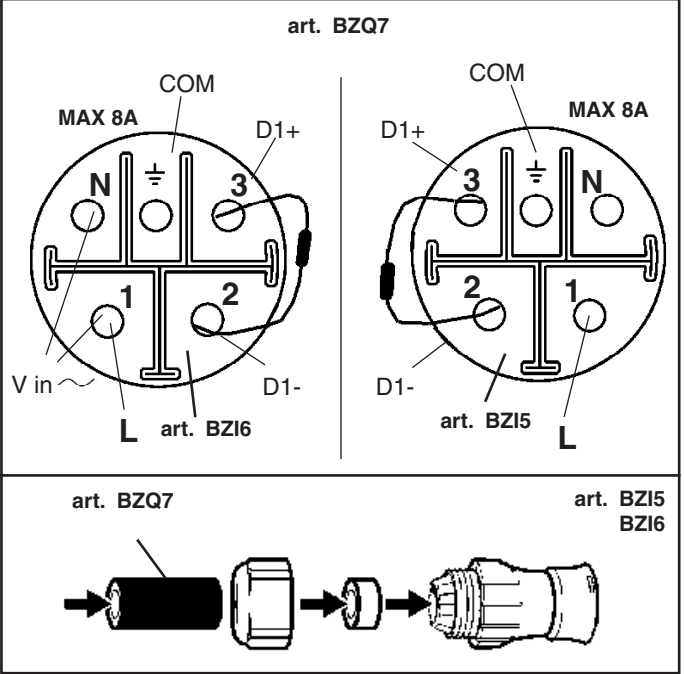

examples

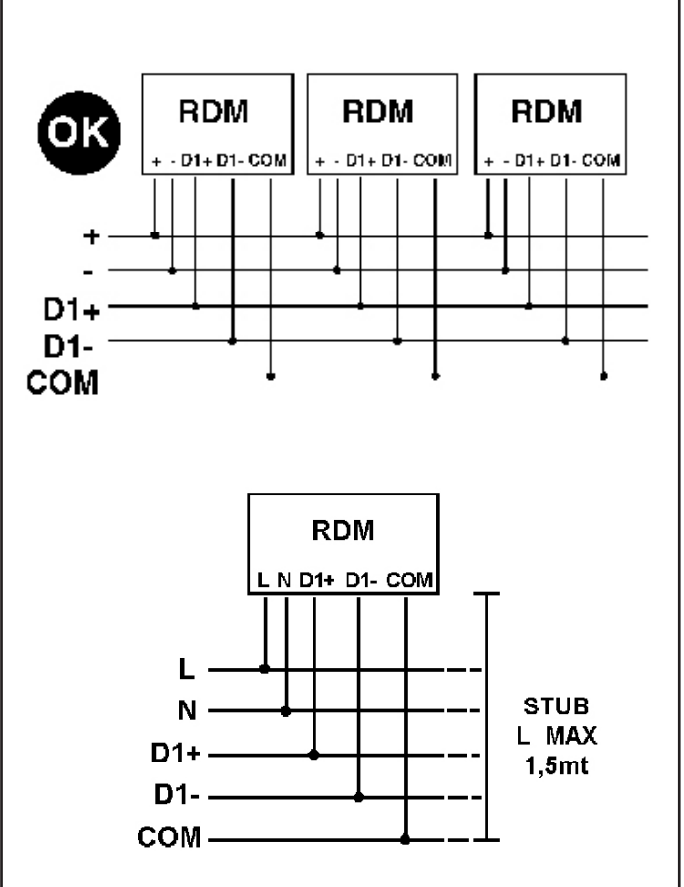

NO DMX

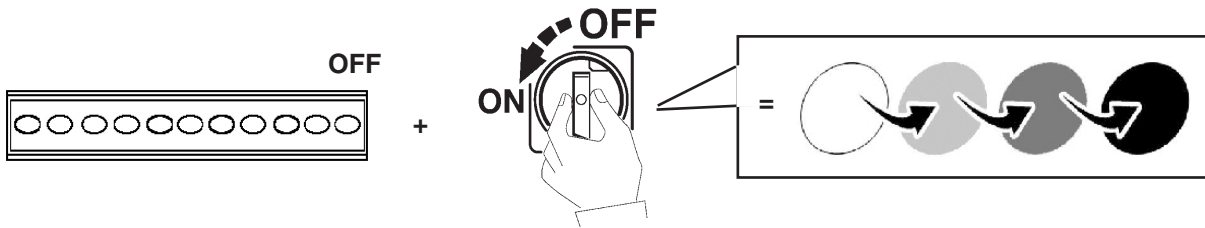

- I "NON SI GARANTISCE IL SINCRONISMO DELLA RUOTA COLORI DI PIU' PRODOTTI ALIMENTATI SENZA SISTEMA DI CONTROLLO DMX".
- GB "COLOUR WHEEL SYNCHRONISM NOT ENSURED IF SEVERAL PRODUCTS POWERED WITHOUT DMX CONTROL SYSTEM".
- F « LE SYNCHRONISME DE LA ROUE DE COULEURS N'EST PAS ASSURÉ EN CAS DE PLUSIEURS APPAREILS ALIMENTÉS SANS SYSTÈME DE CONTRÔLE DMX ».
- D "DER SYNCHRONLAUF DES FARBRADS MEHRERER PRODUKTE, DIE OHNE DMX-STEUERSYSTEM VERSORGT WERDEN, KANN NICHT GEWÄHRLEISTET WERDEN".
- NL "DE SYNCHRONICITEIT VAN HET KLEURENWIEL VAN MEERDERE PRODUCTEN WORDT NIET GEGARANDEERD ALS DEZE NIET WORDEN GEVOED DOOR EEN DMX CONTROLSTYSTEEM".
- E "NO SE GARANTIZA EL SINCRONISMO DE LA VARIACIÓN CROMÁTICA EN CASO DE PRODUCTOS MÚLTIPLES ALIMENTADOS SIN SISTEMA DE CONTROL DMX".
- DK "DER GIVES INGEN GARANTI FOR FARVESTYRINGENS SYNKRONISME FOR FLERE TILSLUTTEDE PRODUKTER UDEN DMX-STYRESYSTEM".
- N «VI KAN IKKE GARANTERE SYNKRONISERING AV FARGEENDRINGEN I FLERE PRDUKTER SOM FUNGERER UTEN DMX KONTROLLSYSTEM».
- S VI GARANTERAR INTE SYNKRONISERAD FÄRGVÄXLING AV FLERA PRODUKTER SOM MATAS UTAN DMX-STYRSYSTEM.
- RUS «НЕ ГАРАНТИРУЕТСЯ СИНХРОНИЗАЦИИ ВАРИАЦИИ ЦВЕТА НЕСКОЛЬКИХ ПРИБОРОВ, ЗАПИТАННЫХ БЕЗ СИСТЕМЫ КОНТРОЛЯ DMX".
- CN "如果多个通电产品无 DMX 控制系统，则无法确保色轮同步。"

- I Maneggiare con cura e non sottoporre a tensioni meccaniche.
- GB Handle with care and do not subject to mechanical stress.
- F Manipuler avec précaution et ne pas soumettre à des contraintes mécaniques.
- D Vorsichtig behandeln und keinen mechanischen Spannungen aussetzen.
- NL Voorzichtig bij het gebruik van dit product. Mag niet worden onderworpen aan mechanische spanning.
- E Manejar con cuidado y no someter a tensiones mecánicas.
- DK Håndter med forsigtighed og udsæt ikke for mekaniske spændinger.
- N Må behandles forsiktig. Må ikke utsettes for mekaniske spenninger.
- S Ska hanteras försiktigt och inte utsättas för mekaniska påfrestningar.
- RUS Обращаться осторожно и не подвергать механическому напряжению
- CN 小心轻放，切勿使其遭受机械应力

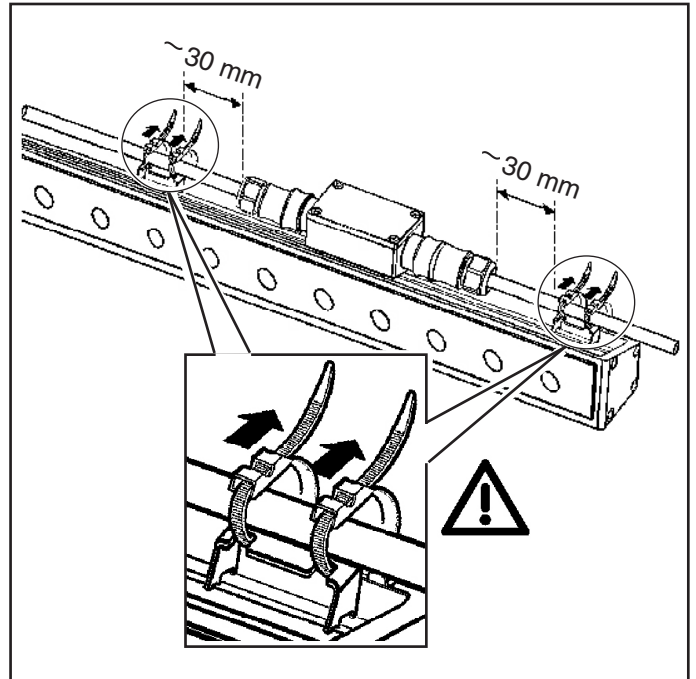
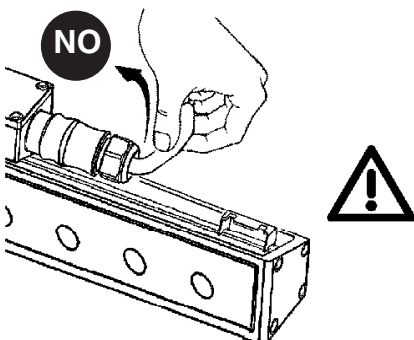
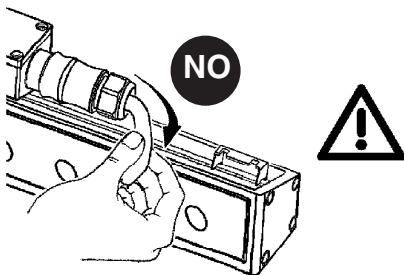
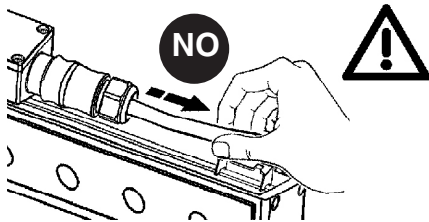

art. BZ10 - BZ11
5570 - 5571
5576 - 5577
5578 - BZV9
BZW0
BZX2
BZX3

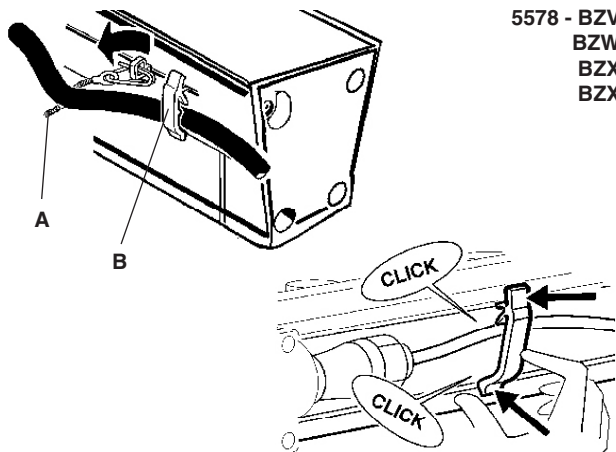

I Prima di bloccare il modulo al supporto meccanico, agganciare i cavetti d'acciaio "A" come indicato in figura. Utilizzare le clips "B" per sistemare i cavi elettrici perfettamente dietro al modulo.

GB Before locking the module onto the mechanical support, hook on the steel cables "A" as indicated in the figure. Use the clips "B" to tidy up the electric cables perfectly behind the module.

F Avant de bloquer le module à son support mécanique, accrochez les filins en acier «A» comme illustré. Utilisez les clips «B» pour bien ranger les câbles électriques derrière le module.

D Bevor Sie das Modul an der Haltevorrichtung festmachen, haken Sie die Stahldrähte "A" ein (siehe Abbildung). Benützen Sie die Clips „B“, um die Stromkabel ordentlich hinter dem Modul festzumachen.

NL Voordat het armatuur aan de mechanische steun wordt bevestigd moeten de staaldraden "A" worden aangehaakt zoals aangegeven in de afbeelding.

E Antes de fijar el módulo al soporte mecánico, enganchar los cables de acero «A» según ilustrado en la figura. Utilizar las clips «B» para el perfecto alojamiento de los cables en el módulo.

DK Inden modulet fastgøres til det mekaniske beslag, skal stålkablerne "A" hægtes på, som vist i figuren. Brug klemmerne "B" til at samle de elektriske ledninger bag modulet.

N Før modulet låses på den mekaniske støtten, festes stålkablene "A" slik som vist på figuren. Bruk klemmene "B" til å ordne de elektriske kablene bak modulet.

S Haka fast stålrådarna A enligt figuren innan modulen sätts fast i den mekaniska hållaren. Använd klämmorna B för att placera elkablarna korrekt bakom modulet.

RUS Перед закреплением модуля на механической опоре подсоедините стальные тросы «А», как показано на схеме. Используйте зажимы «В» для крепления электрических проводов в точности позади модуля.

CN 在将模块锁到机械支架上前，如图所示将其钩在钢缆“A”上。用夹子“B”整理模块后的电缆。



N.B.: DURANTE L'INSTALLAZIONE DEL SISTEMA RISPETTARE SCRUPolosAMENTE LE NORME IMPIANTISTICHE VIGENTI.

N.B.: WHEN INSTALLING THE SYSTEM, STRICTLY COMPLY WITH ALL REGULATIONS ON INSTALLATION IN FORCE.

N.B.: LORS DE L'INSTALLATION DU SYSTÈME VEUILLEZ RESPECTER RIGOREUSEMENT LES NORMES EN VIGUEUR EN LA MATIÈRE.

NB: BEACHTEN SIE BEI DER INSTALLATION DES SYSTEMS GEWISSENHAFT DIE GÜLTIGEN BESTIMMUNGEN BEZÜGLICH DER ANLAGENTECHNIK.

N.B.: BIJ HET INSTALLEREN VAN HET SYSTEEM MOET U DE GELDEN DE INSTALLATIE-NORMEN STRIKT NALEVEN.

N.B.: DURANTE LA INSTALACIÓN DEL SISTEMA RESPETAR E SCRUPolosAMENTE LAS NORMAS DE INSTALACIÓN VIGENTES.

N.B.: UNDER INSTALLATION AF SYSTEMET SKAL MAN NØJE OVERHOLDE DE GÆLDENDE REGLER FOR DISSE ANLÆG.

N.B.: VED INSTALLASJON AV SYSTEMET SKAL ALLE FORSKRIFTER OM INSTALLASJON SOM GJELDER FØLGES STRENGT.

OBS! UNDER INSTALLATIONEN AV SYSTEMET SKA INSTALLATIONSFØRESKRIFTERNA RESPEKTERAS I DETALJ.

ПРИМЕЧАНИЕ: В ПРОЦЕССЕ МОНТАЖА СИСТЕМЫ СТРОГО СОБЛЮДАЙТЕ НАЦИОНАЛЬНЫЕ ДЕЙСТВУЮЩИЕ НОРМАТИВЫ ПО ЭЛЕКТРОПРОВОДКЕ.

注意：在安装系统时请遵守设备的安装规定。

I N.B.: Per la sostituzione del LED contattare l'azienda iGuzzini.

GB N.B.: For information on LED replacement please contact iGuzzini.

F N.B.: Pour procéder au remplacement de la LED, adressez-vous à la société iGuzzini.

D Ñ.B.: Bezüglich des Austausches der LED kontaktieren Sie bitte die Firma iGuzzini.

NL N.B.: Voor het vervangen van de LED neemt u contact op met het bedrijf iGuzzini.

E NOTA: Para sustituir el LED llame a la empresa iGuzzini.

DK N.B.: For udskiftning af lysdioden, skal man kontakte iGuzzini.

N N.B.: For informasjon om skifte av LED, vennligst ta kontakt med iGuzzini.

S OBS! För byte av lysdioden, kontakta företaget iGuzzini.

RUS ПРИМЕЧАНИЕ: Для замены СИДов обращайтесь в компанию iGuzzini.

CN 注意：如需LED更换的信息，请联系iGuzzini。



- I In caso di rottura delle lenti il prodotto non può essere utilizzato, contattare il costruttore per la sua sostituzione.
- GB Should the lenses break, the product cannot be used. Contact the manufacturer for replacement.
- F En cas de rupture des lentilles, le produit ne peut plus être utilisé. Contacter le fabricant pour procéder à son remplacement.
- D Im Falle einer Beschädigung der Linsen darf das Produkt nicht verwendet werden. Setzen Sie sich bitte mit dem Hersteller in Verbindung, der für den Ersatz sorgen wird.
- NL Indien de lenzen kapot zijn kan het product niet geïnstalleerd worden. Neem contact op met de fabrikant om ze te vervangen.
- E En caso de rotura de las lentes, el producto no puede utilizarse y se debe contactar con el fabricante para su sustitución.
- DK Hvis produktets linser ødelægges, kan det ikke anvendes. Kontakt producenten med henblik på udskiftning.
- N Hvis linsene blir ødelagt kan ikke produktet brukes lenger. Ta kontakt med produsenten for å få det skiftet ut.
- S Produkten kan inte användas vid brott på linser. Kontakta tillverkaren för byte av linser.
- RUS В случае повреждения линз прибор нельзя использовать, обратиться к производителю для его замены.
- CN 如果镜头破裂，请不要使用该产品。请联系制造商进行更换。

art. BZH7 - BZH8 - BZH9 - BZT1 - BZT2 - BZT3
BZV6 - BZV7 - BZV8

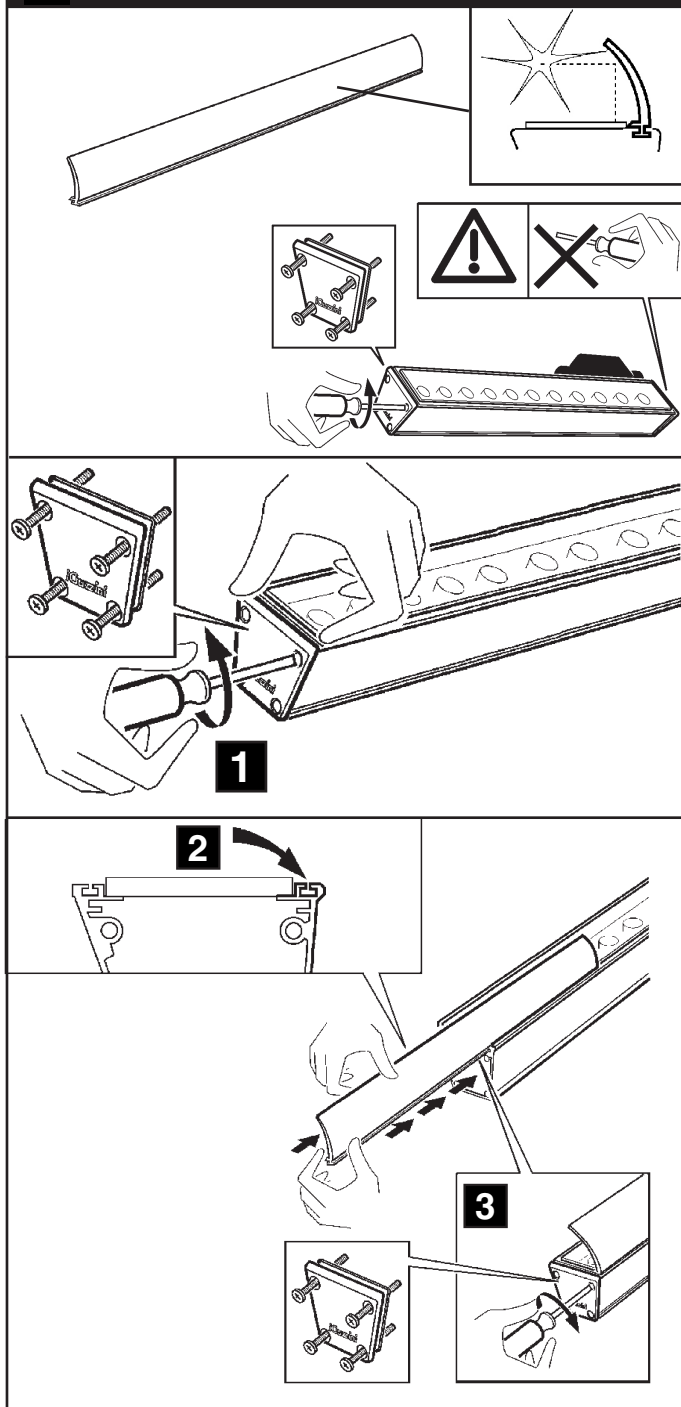

ART.	BZW8	BZW9
BP12 - BP14	●	/
BP13 - BP15	/	●

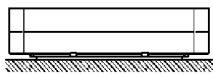
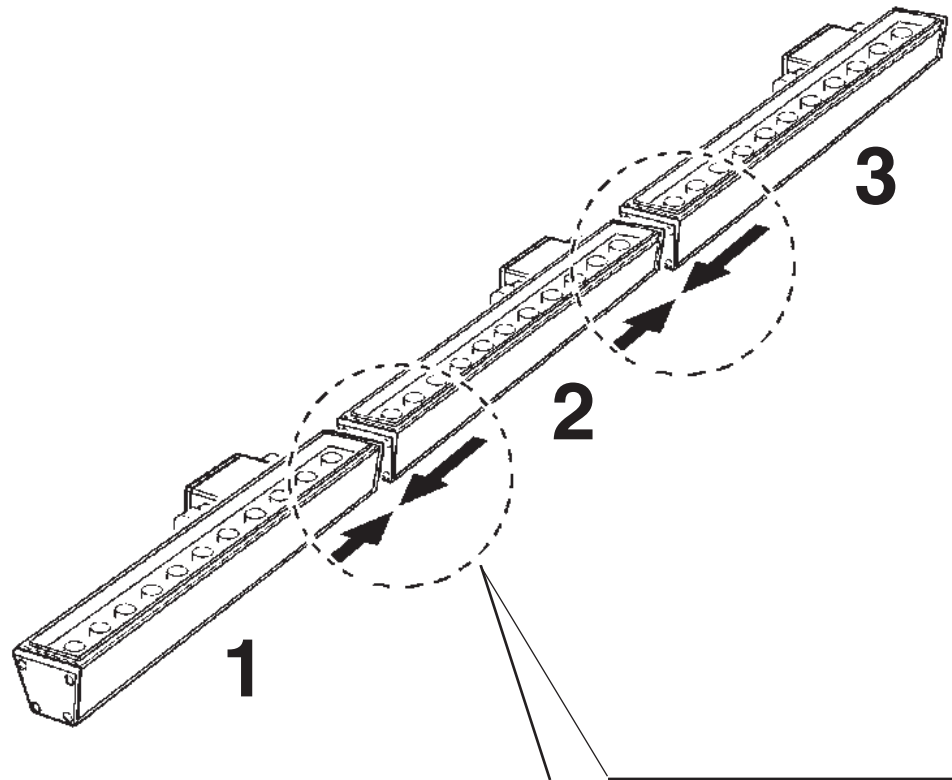

+

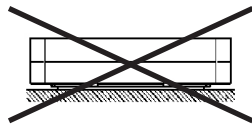

+

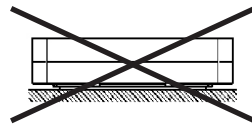

+

...

NO

1
WRGB W
art. BN90 - BN91 - BN92

2
WRGB W
art. BN90 - BN91 - BN92

3
WRGB W
art. BN90 - BN91 - BN92

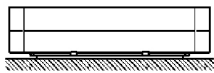

+



+



+

...

OK

1
WRGB W
art. BN90 - BN91 - BN92

2
RGB W
art. BN90 - BN91 - BN92

3
RGB W
art. BN90 - BN91 - BN92

LINEALUCE COMPACT 75
MONOCHROME - RGB
RGBW - WRGBW
WNC (DMX - RDM)

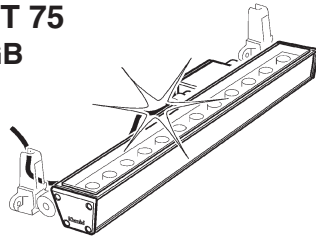

تحذير:

لا يمكن ضمان سلامة هذا الجهاز إلا إذا التزمت بهذه التعليمات. يجب حفظها في مكان آمن.

ATTENZIONE:

LA SICUREZZA DELL'APPARECCHIO E' GARANTITA SOLO CON L'USO APPROPRIATO DELLE SEGUENTI ISTRUZIONI; PERTANTO E' NECESSARIO CONSERVARLE.

WARNING:

THE SAFETY OF THIS FIXTURE IS GUARANTEED ONLY IF YOU COMPLY WITH THESE INSTRUCTIONS; REMEMBER TO CONSERVE IN A SAFE PLACE.

ATENCION:

LA SEGURIDAD DEL APARATO SE GARANTIZA SOLO CUMPLIENDO CUIDADOSAMENTE LAS SIGUIENTES INSTRUCCIONES; POR ELLO, ES NECESARIO CONSERVARLAS.

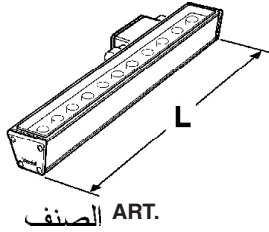
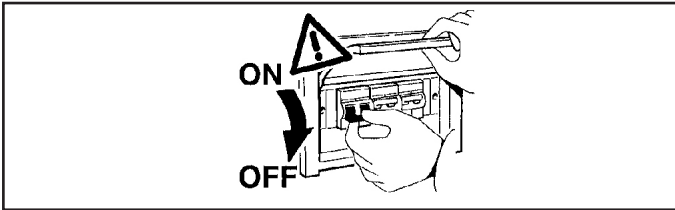

ملم
L (mm)

ART. الصنف	L (mm)
BN90	540
BI63 - BI64	528
BI72 - BM45 - BM66 - BP14	506
BN91	1026
BI65 - BI66	1056
BI73 - BM46 - BM67 - BP15	998
BI67 - BI68	1585
BI74 - BM47 - BM68	1490
BN92	1511

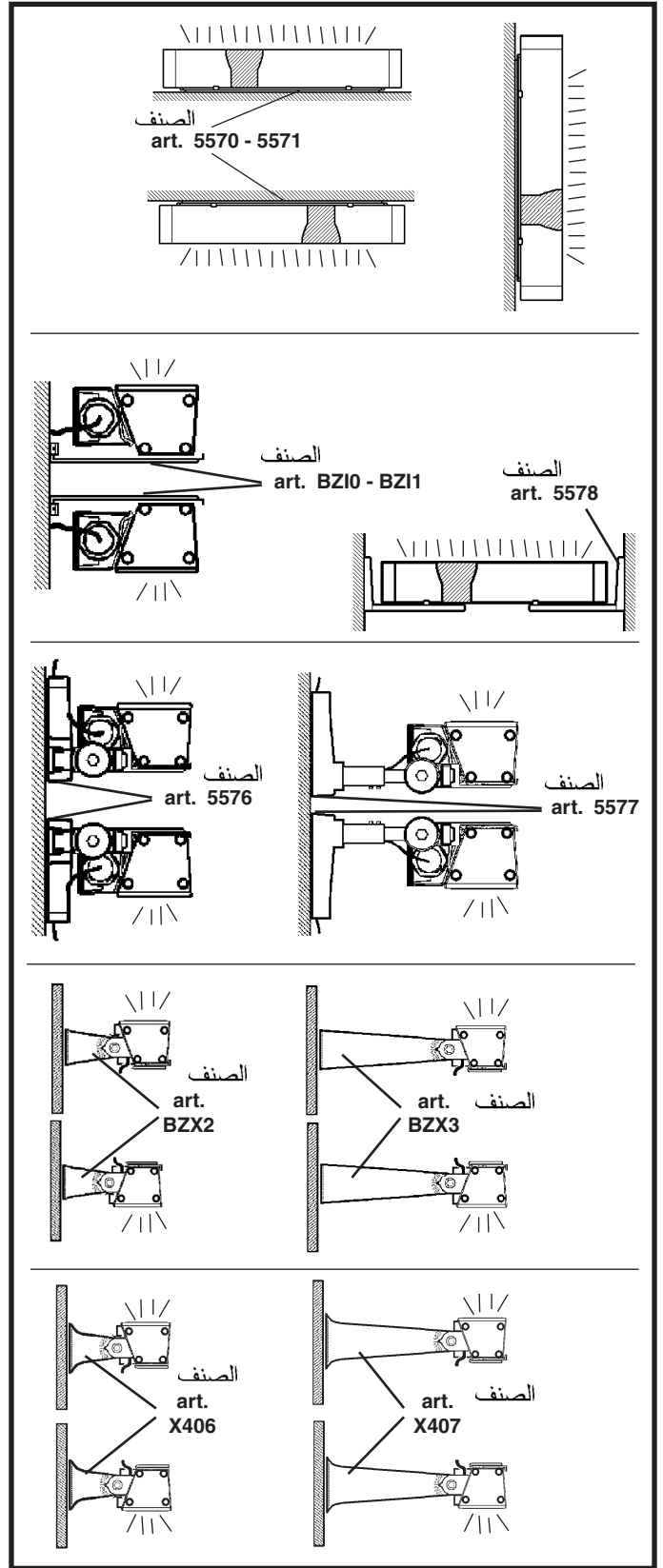
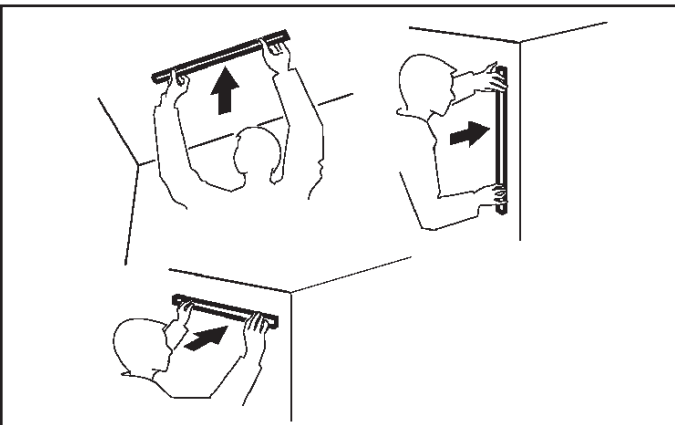

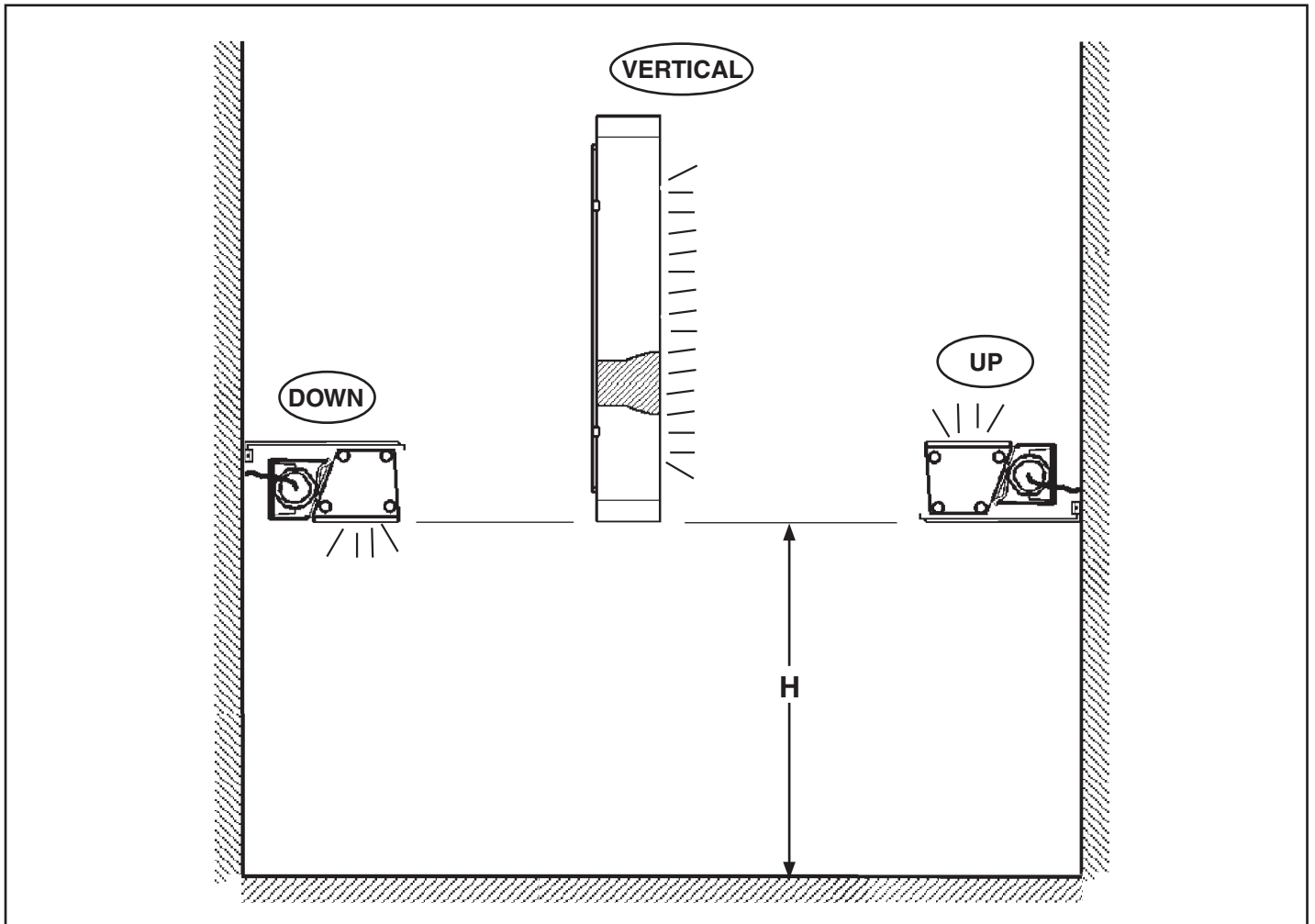

ACCESSORIES		H > 3m			H < 3m		
الصفحة art.		UP	DOWN	VERTICAL	UP	DOWN	VERTICAL
	5570 - 5571	✓	✗	✗	✓	✓	✓
	5578	✓	✗	✗	✓	✗	✗
	BZIO - BZI1	✓	✗	✗	✓	✓	✗
	5576 - 5577	✓	✗	✗	✓	✓	✗
	BZX2 - BZX3	✓	✗	✗	✓	✓	✗
	X406 - X407	✓	✓	✗	✓	✓	✗

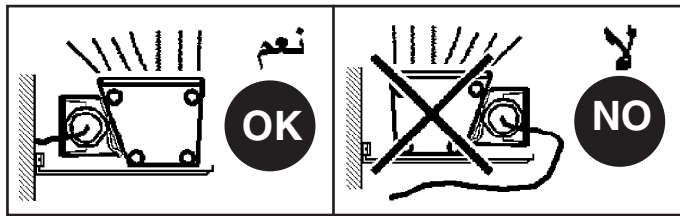
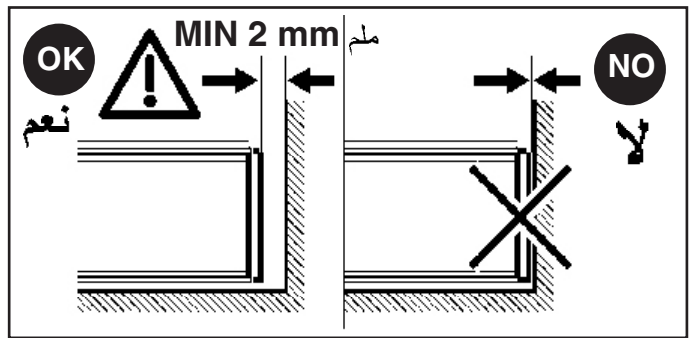
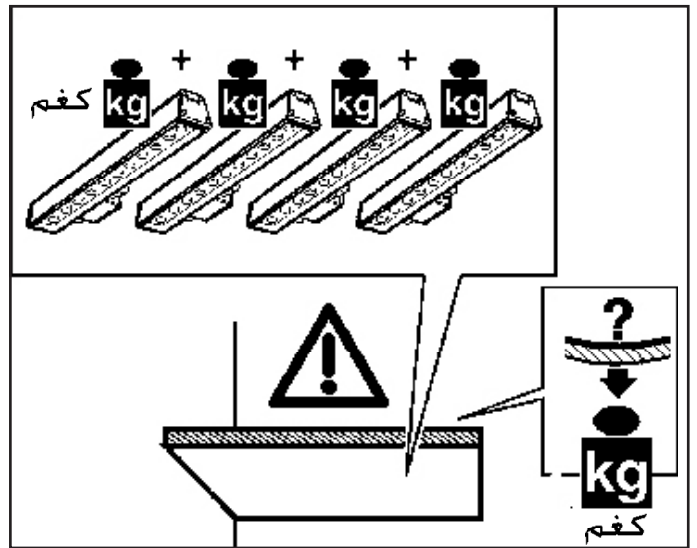
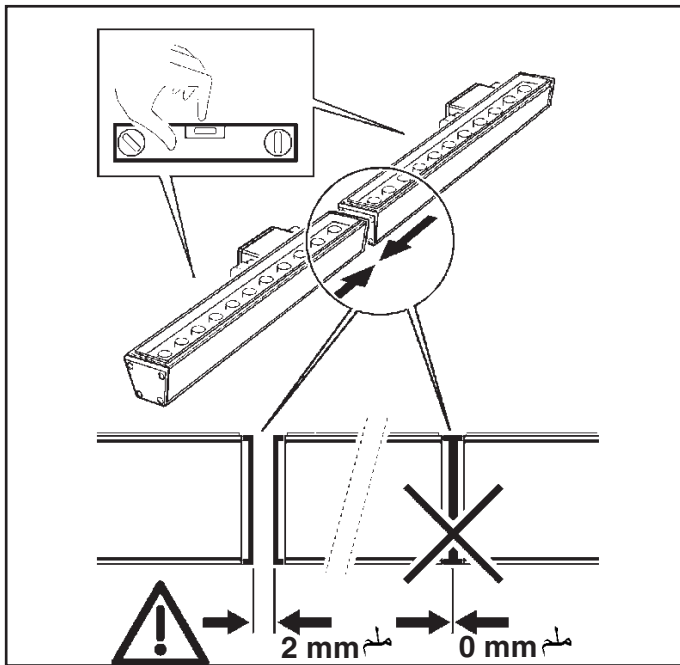

تركيب الدعائم الميكانيكية

INSTALLAZIONE DEI SUPPORTI MECCANICI - INSTALLATION OF THE MECHANICAL SUPPORTS
INSTALACIÓN DE LOS SOPORTES MECÁNICOS

جدول مسافات الفتحات من المركز للمركز

TABELLA INTERASSI DI FORATURA - TABLE CENTRE TO CENTRE DISTANCE BETWEEN HOLES
TALADRAR DISTANCIA ENTRE LOS EJES DE PERFORACIÓN

L (mm)	ART.	BZI0 K(mm)	BZI1 K(mm)	5570 5571 K(mm)	BZX2 X406 K(mm)	5576 K(mm)	BZX2 X407 K(mm)	5577 K(mm)	BZX2-BZX3 X406-X407 5576-5577 Y(mm)	5578 K(mm)	BZV9 Y(mm)	BZW0 K(mm)
528	BI63 - BI64	240	-	265	396	440	396	440	-	-	-	-
506	BI72 - BM66	240	-	265	374	420	374	420	-	-	-	-
506	BM45	-	-	-	-	-	374	420	-	-	240	-
540	BN90	-	-	-	-	-	-	-	-	-	240	-
506	BP14	-	-	-	-	-	-	-	-	-	-	-
1056	BI65 - BI66	240	-	265	924	970	924	970	-	1106 ÷ 1386	-	-
998	BI73 - BM67	240	-	265	866	910	866	910	-	1106 ÷ 1386	-	-
998	BM46	-	-	-	-	-	-	-	-	-	240	-
1026	BN91	-	-	-	-	-	-	-	-	-	240	-
998	BP15	-	-	-	-	-	866	910	-	-	-	-
1585	BI67 - BI68	-	600	600	1453	1500	1453	1500	750	1635 ÷ 1915	-	-
1490	BI74 - BM68	-	600	600	1358	1400	1358	1400	750	1635 ÷ 1915	-	-
1490	BM47	-	-	-	-	-	-	-	750	-	-	600
1511	BN92	-	-	-	-	-	-	-	750	-	-	600

ART. 5576 - 5577 - BZX2 - BZX3 - X406 - X407

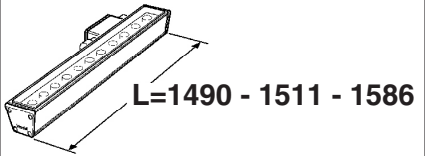

NO

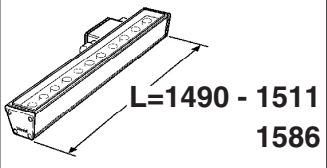
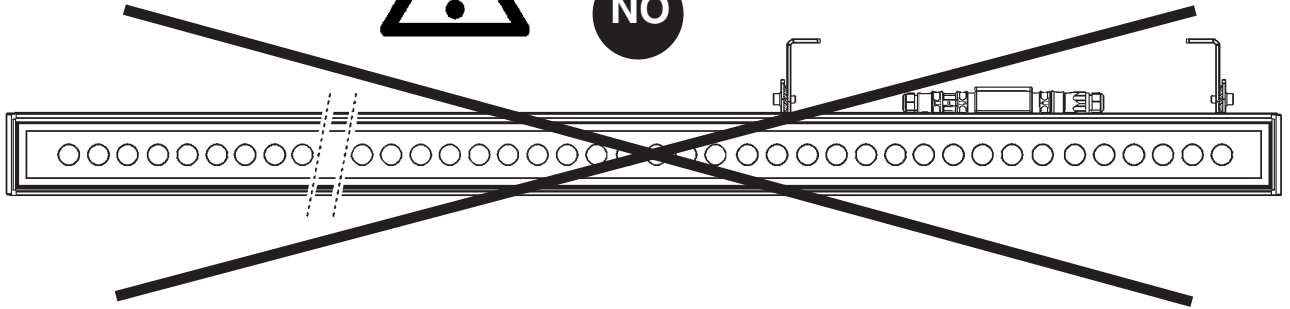

نعم
OK

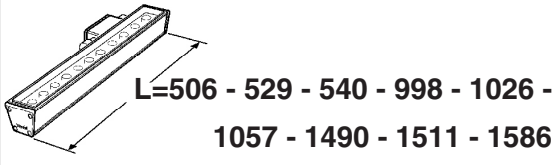
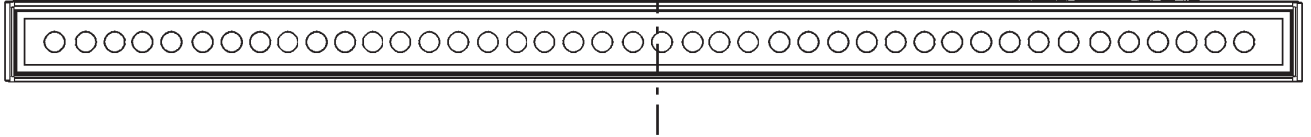
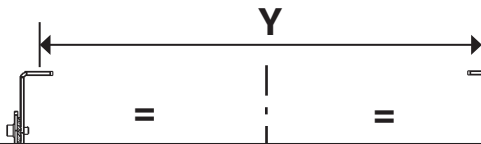

نعم
OK

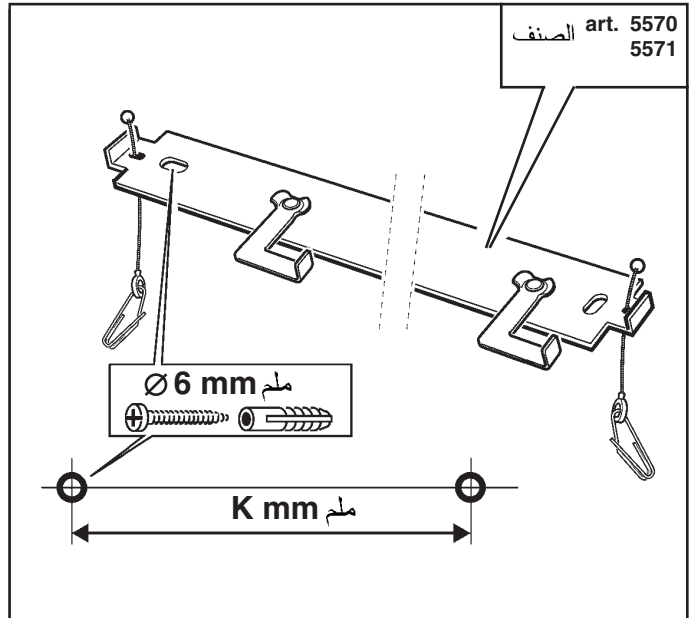
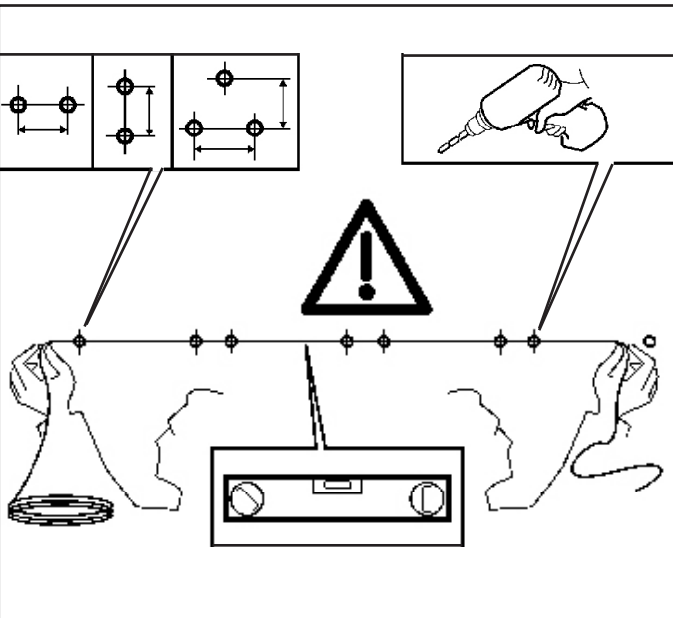
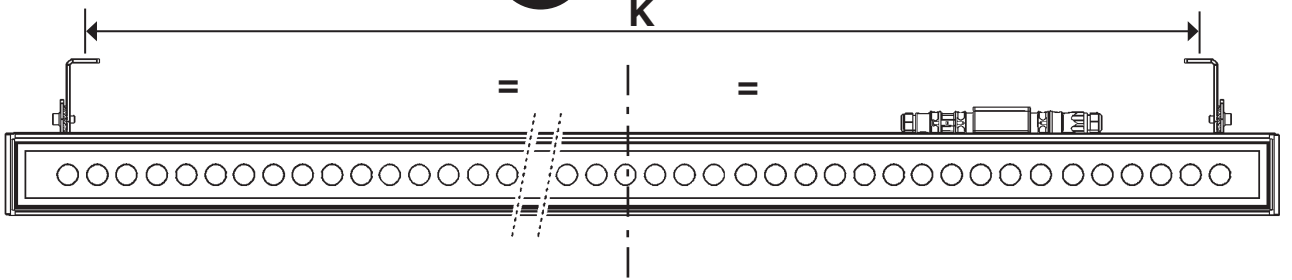

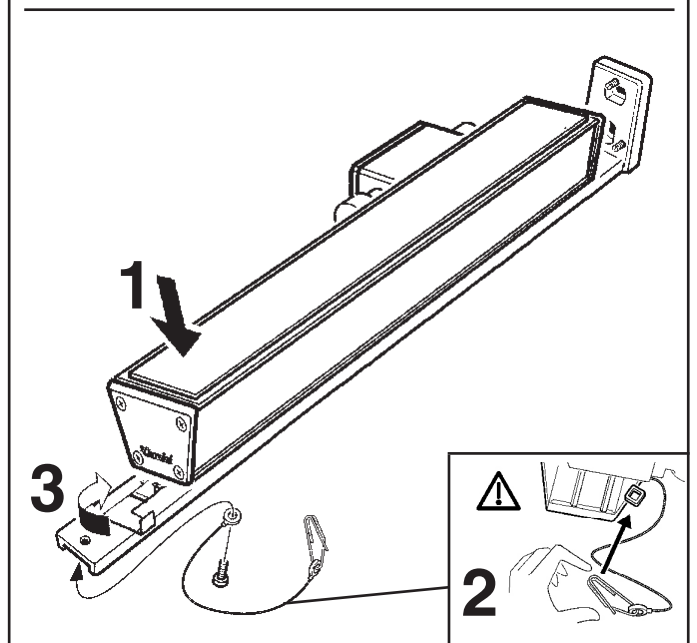
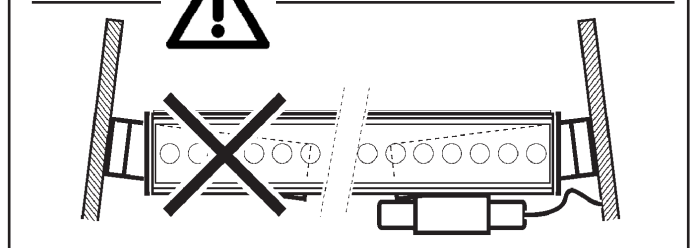
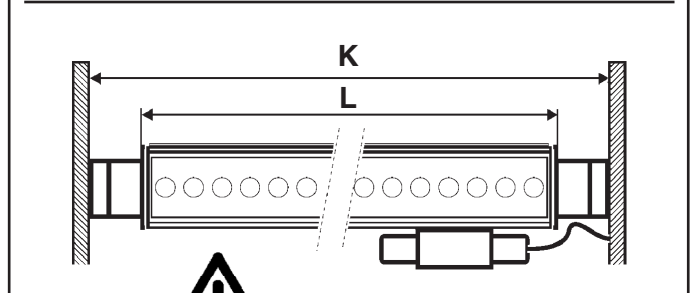
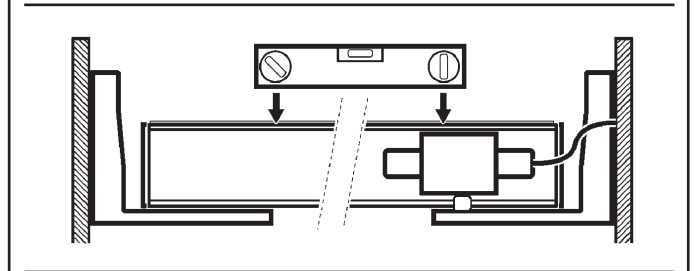
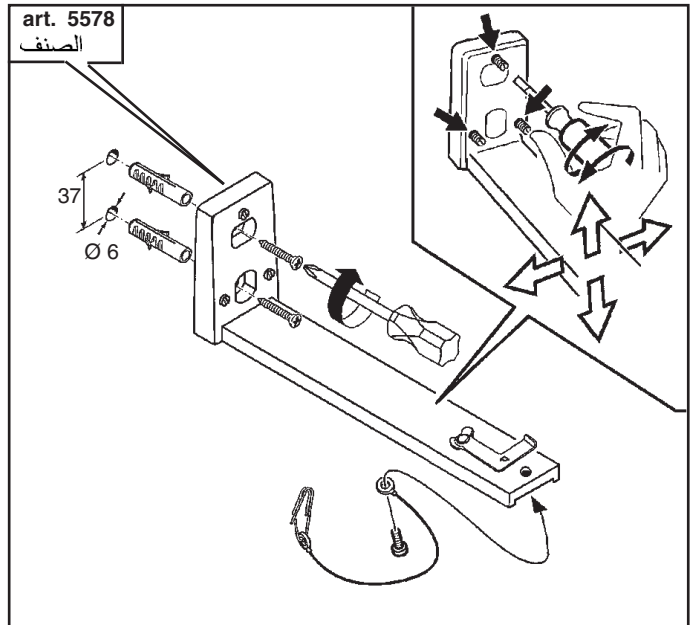
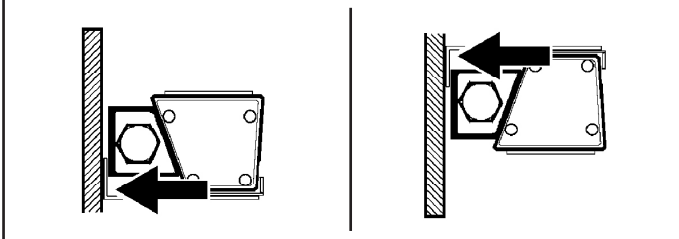
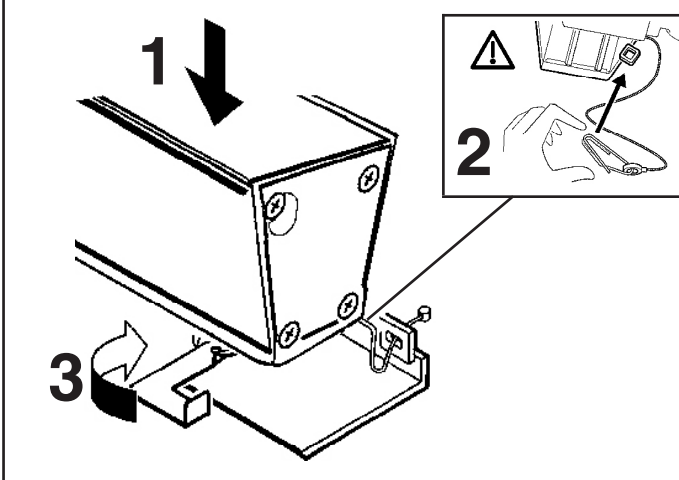
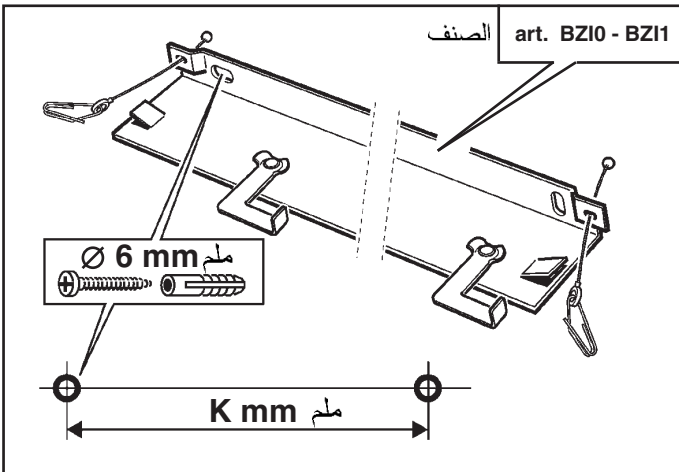
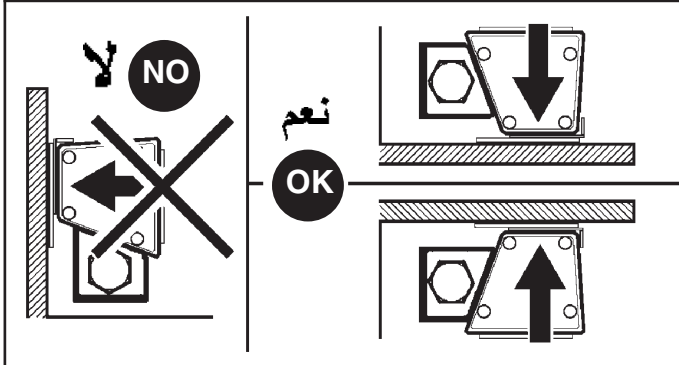
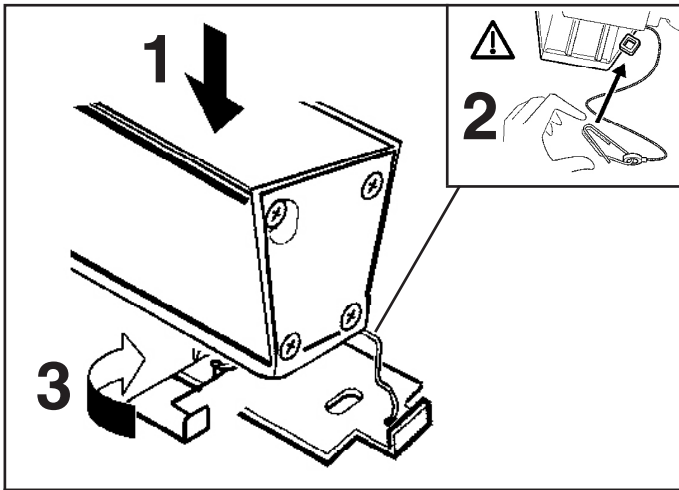

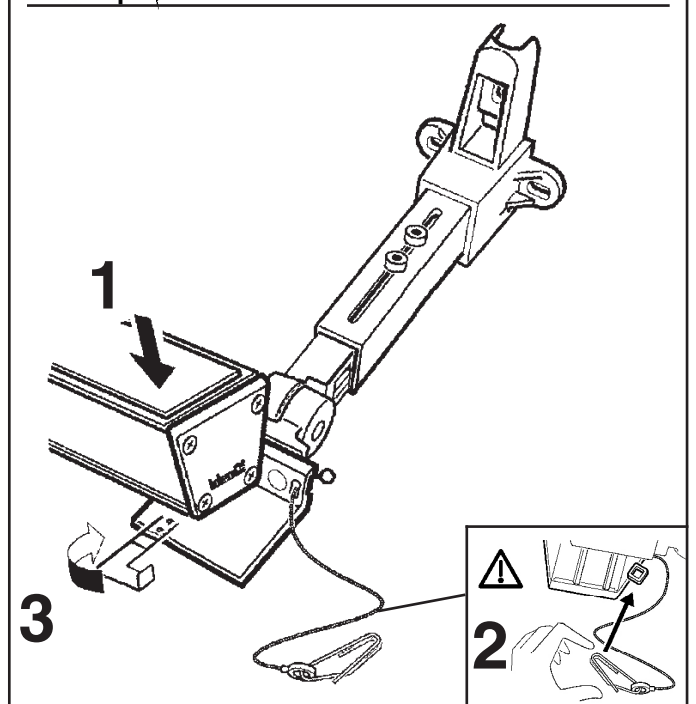
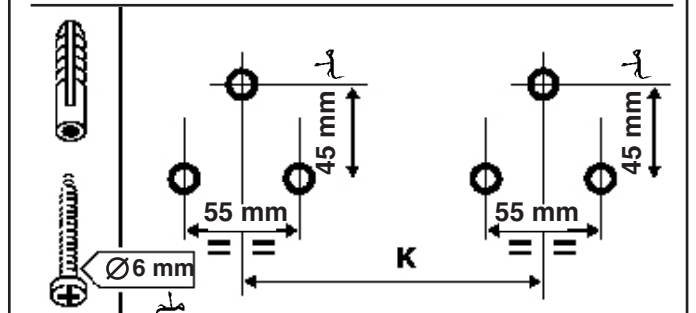
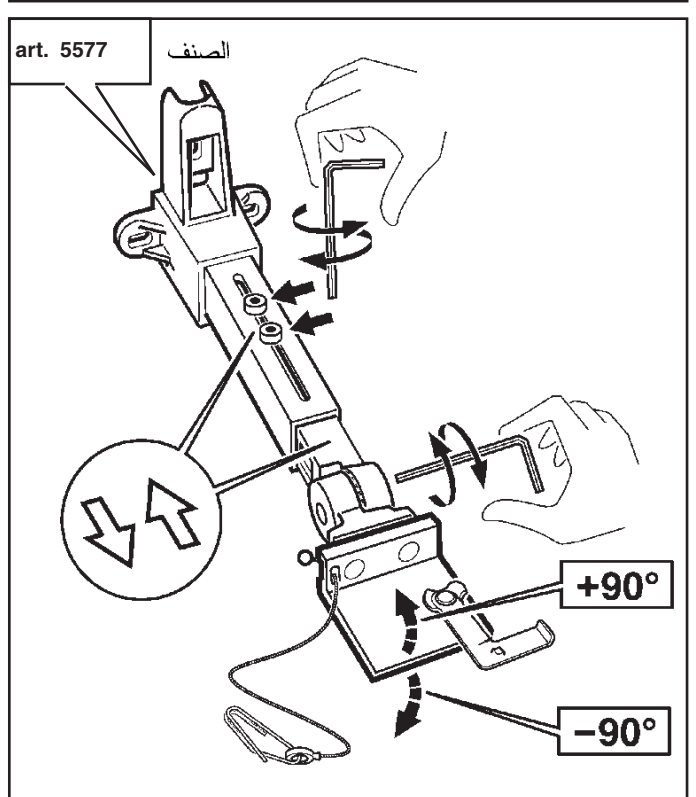
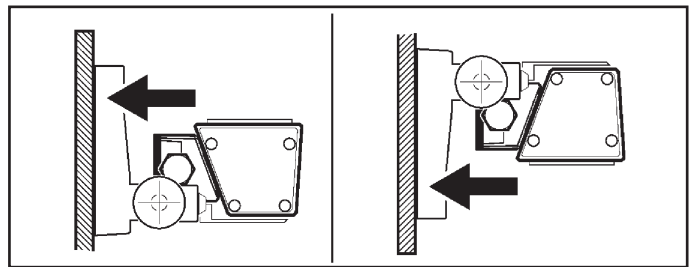
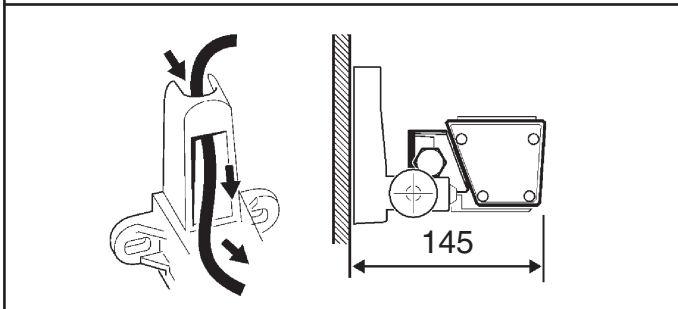
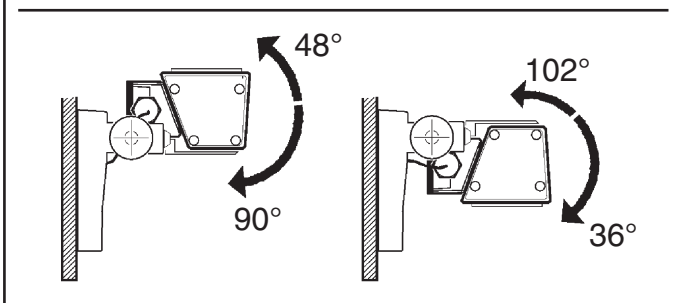
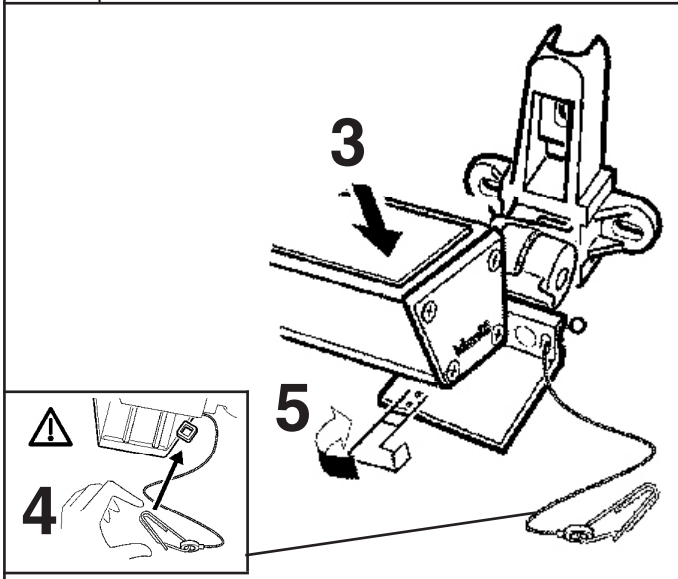
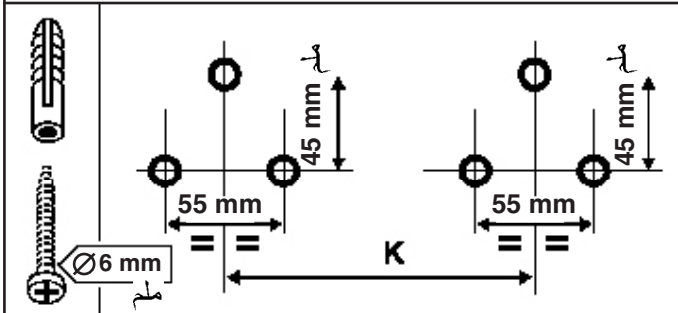
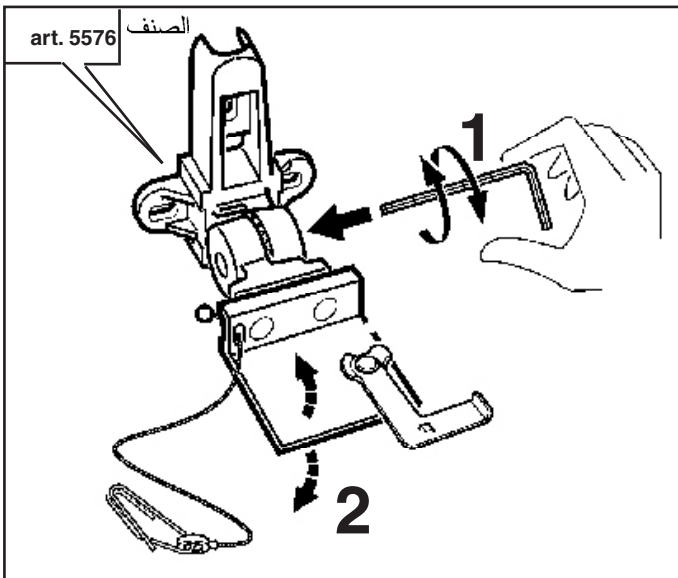

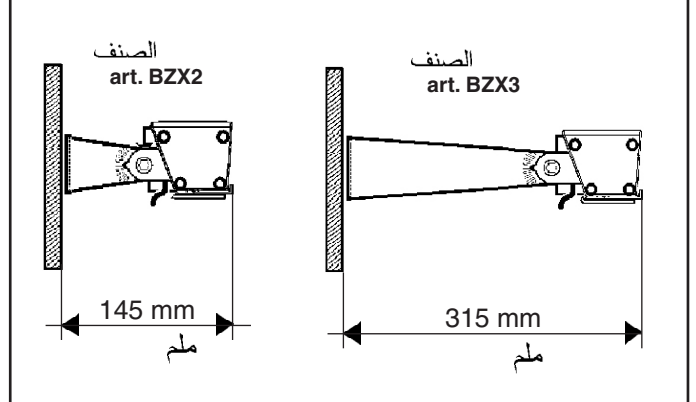
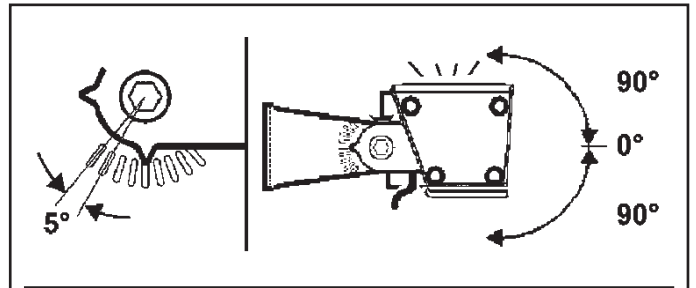
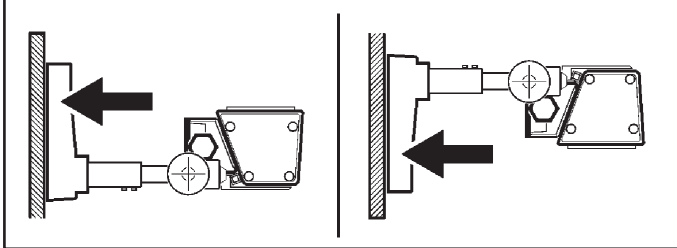
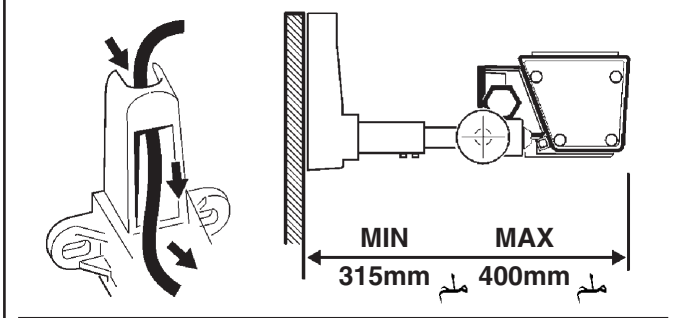
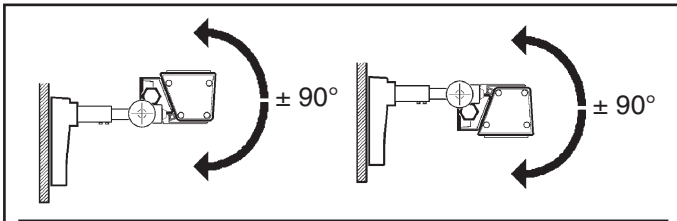

الصنف art. BZX2 - BZX3

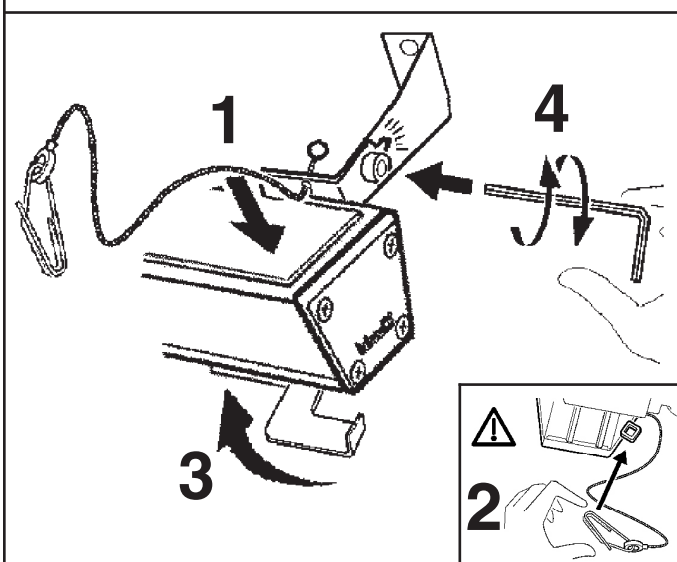
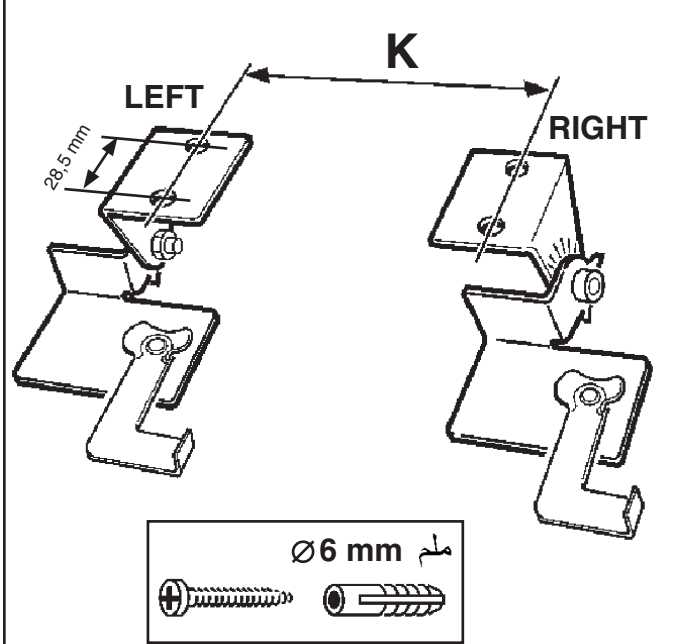

الصنف art. 5570 - 5571 - 5576 - 5577 - 5578 - BZIO
BZI1 - BZX2 - BZX3

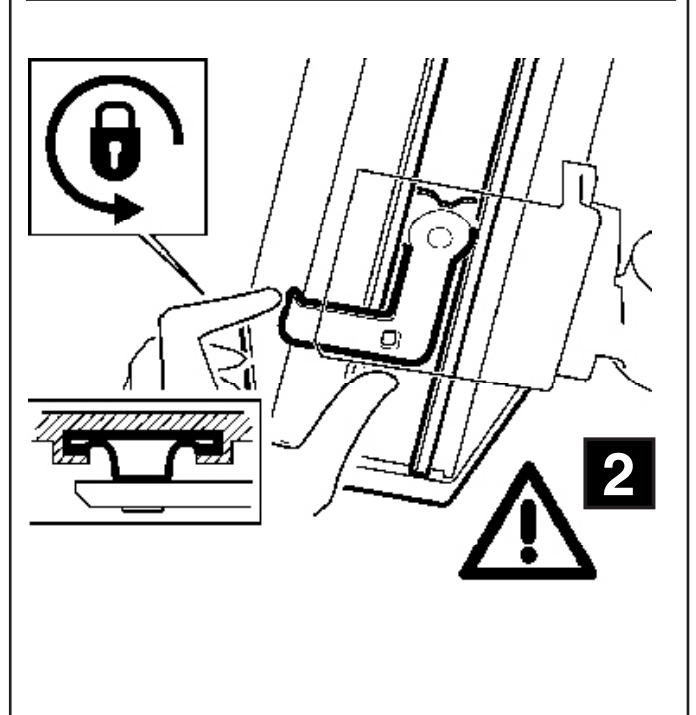
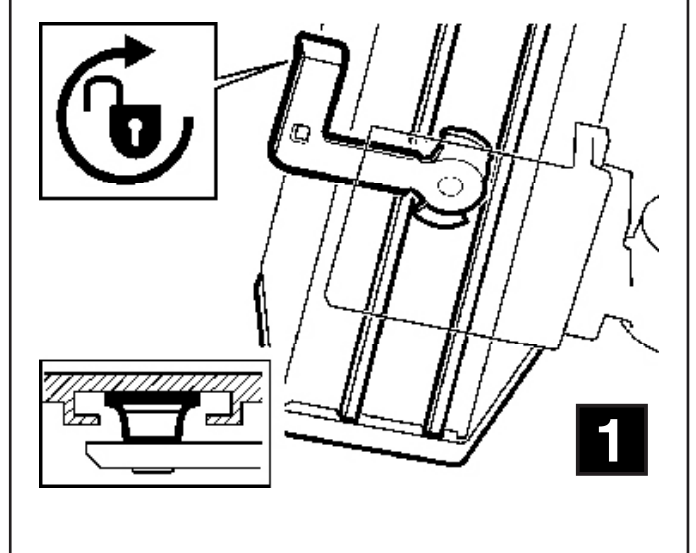

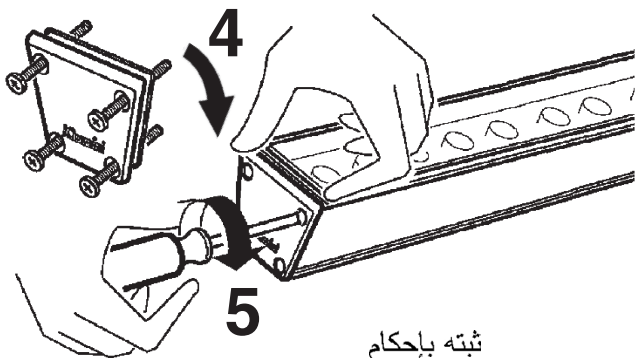
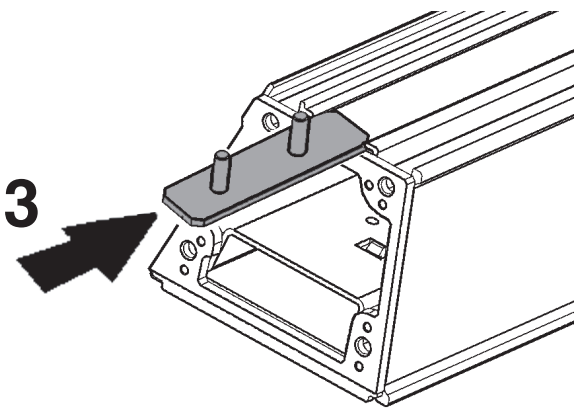
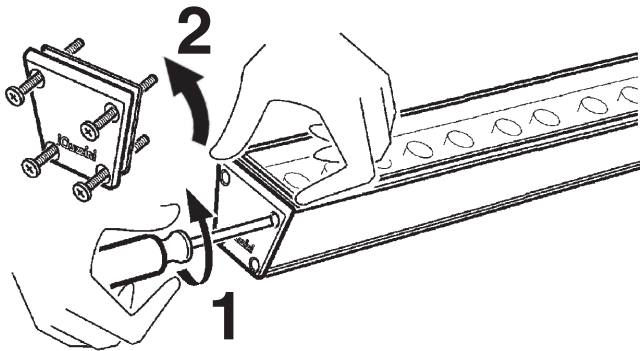
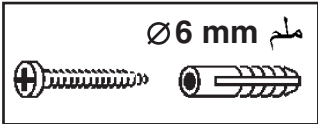
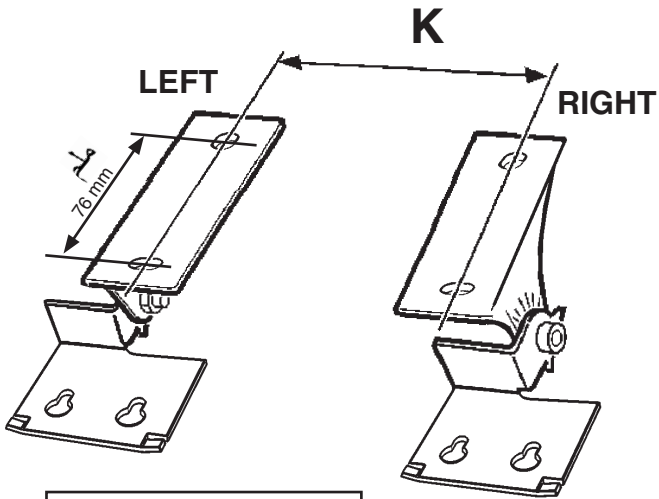

ثبته بإحكام
Serrare a fondo
Tighten firmly
Enroscar en firme

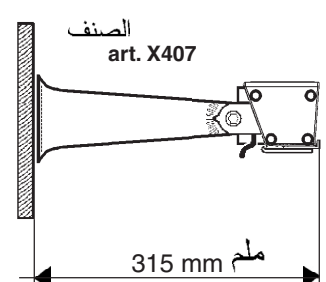
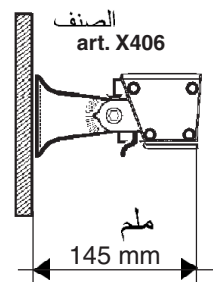
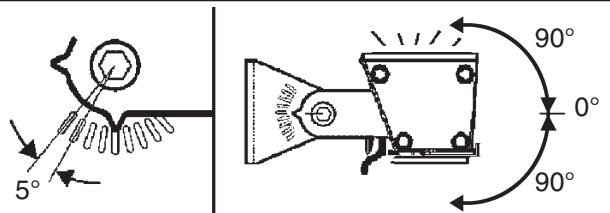
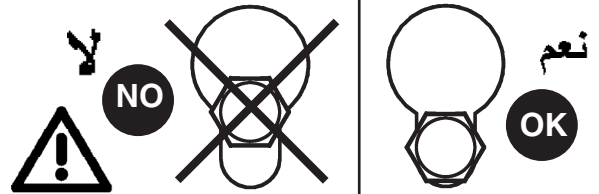
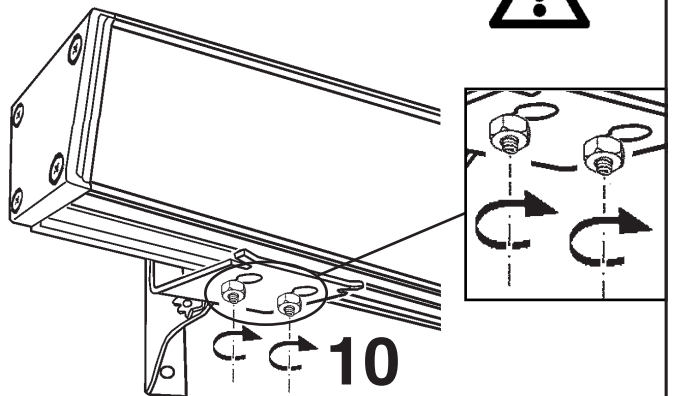
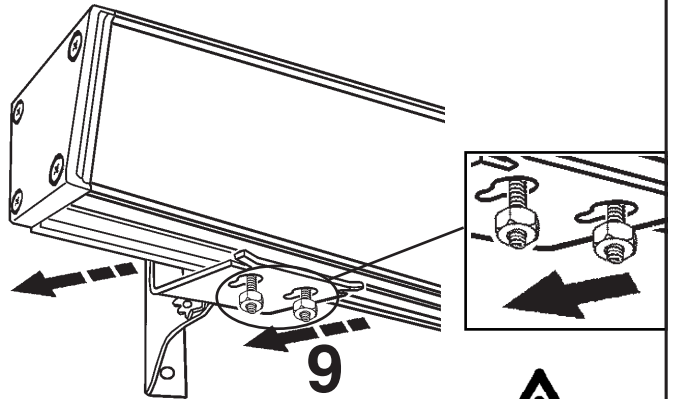
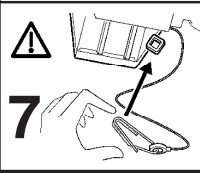
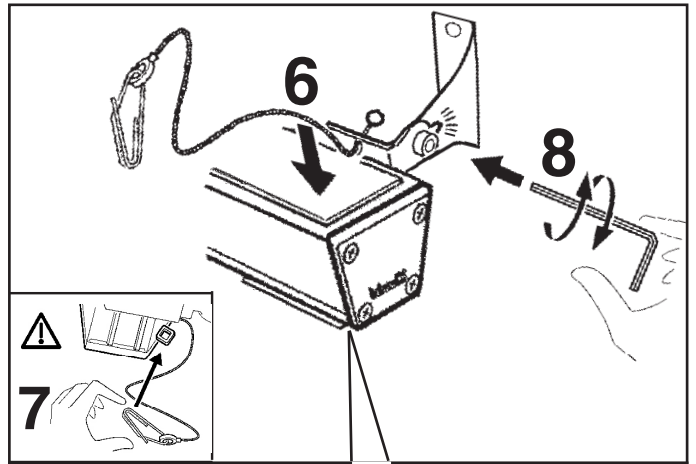

DMX

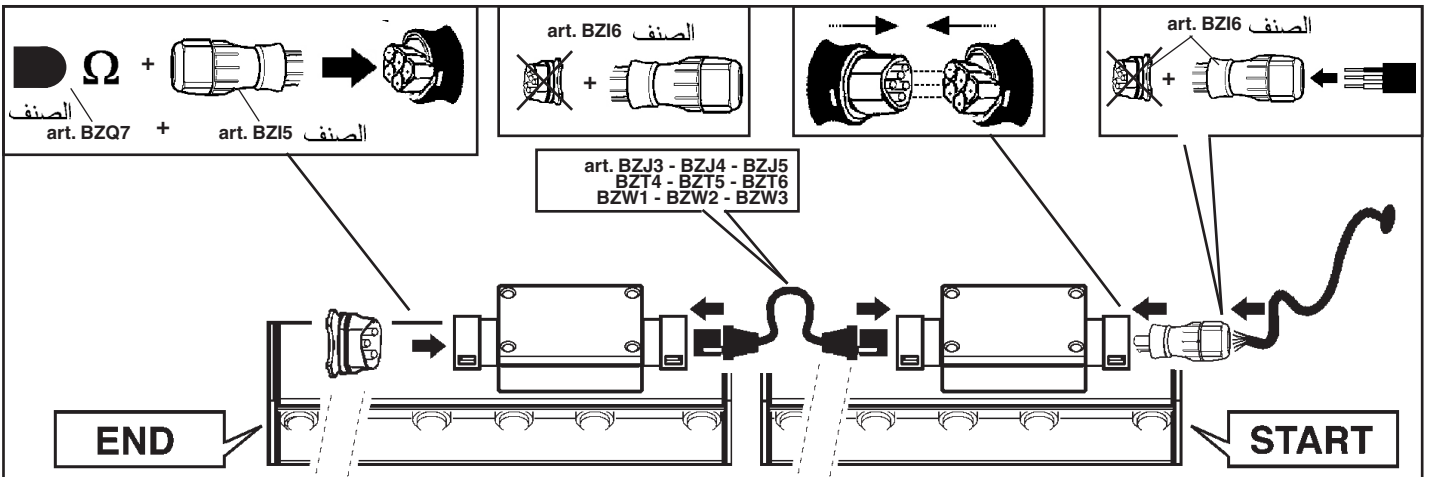
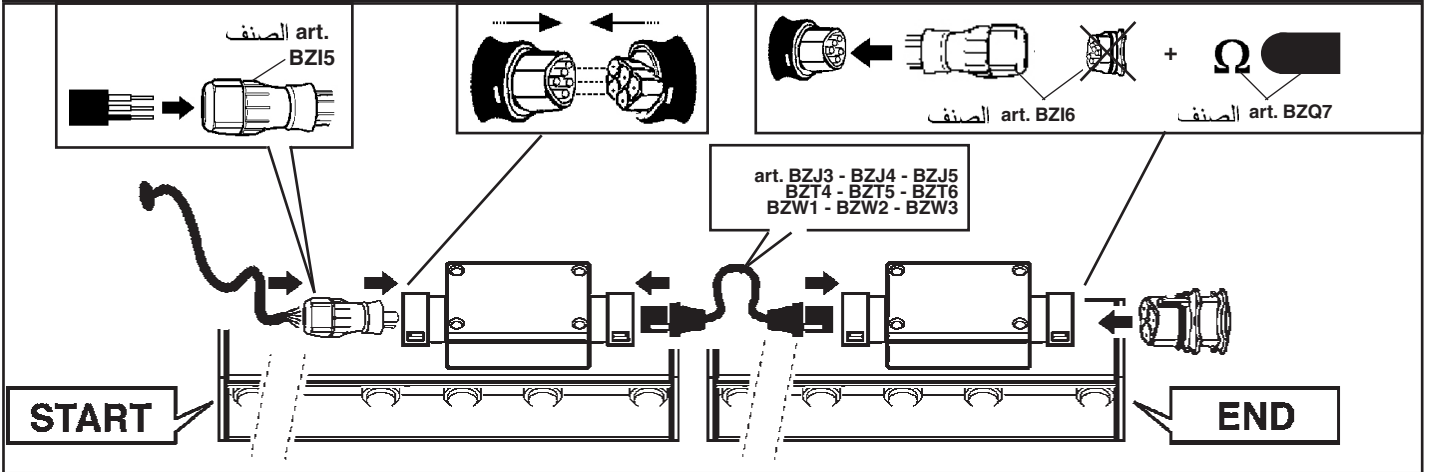
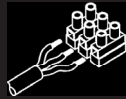

Vin = 160-305V
Vin = 127-400V

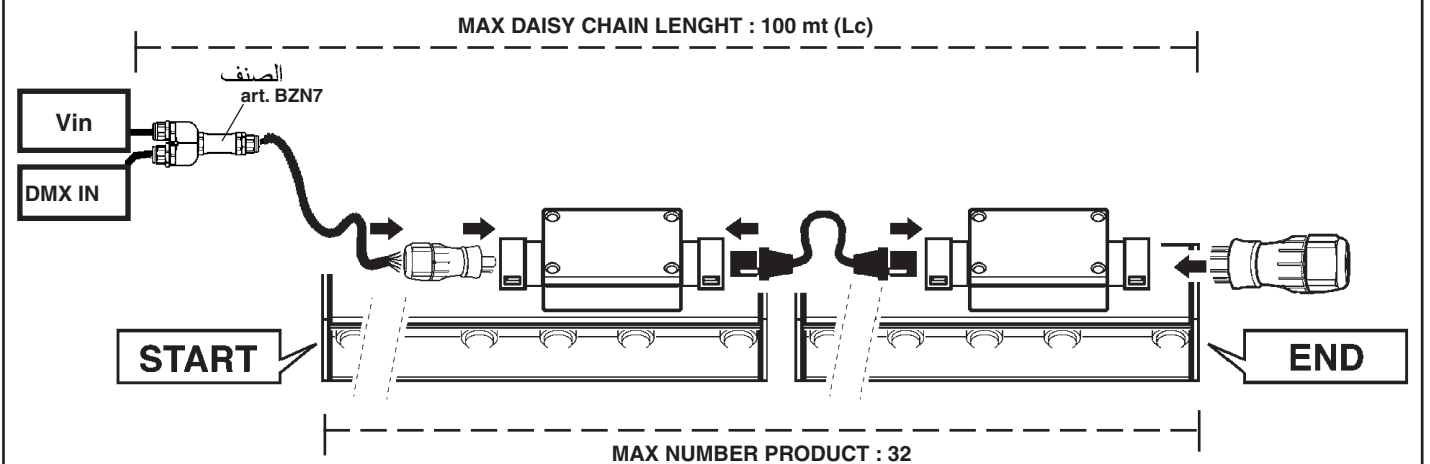

DMX DAISY CHAIN:

1. Max number products: 32
2. Max Daisy Chain Length: 100 meters (Lc)

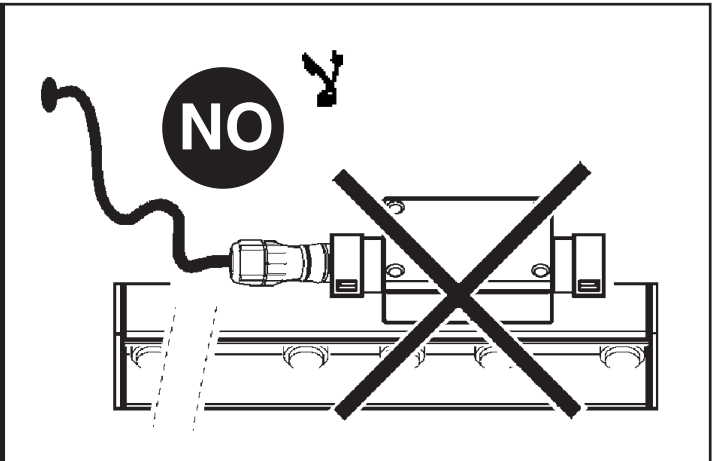
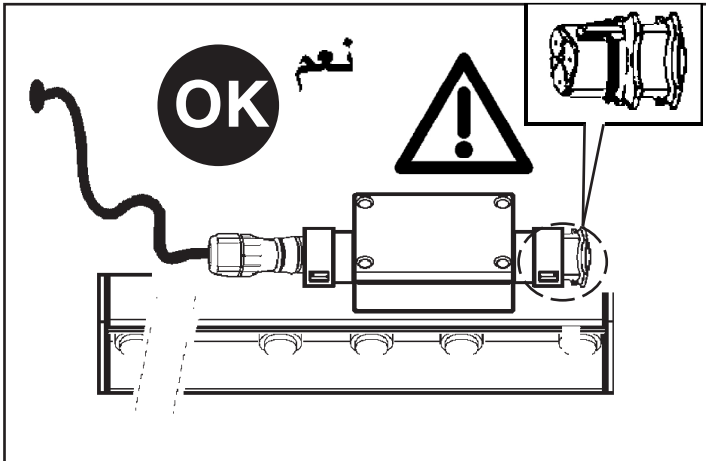
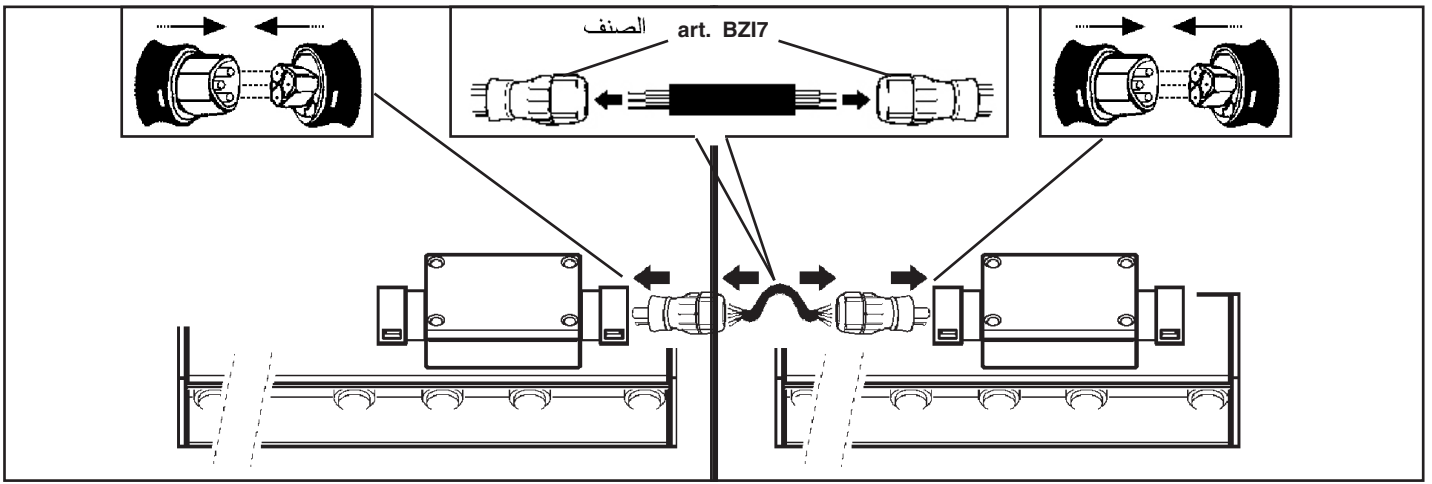

ART.	عدد الأقطاب n° poli n° poles n° polos	كابل cavo cable cable ملم Ø (mm)	المقطع Sezione Section Sección ملم ² mm ²
BZI5	5	10 ÷ 14mm	1,5 ÷ 2,5 mm ²
BZI6			
BZI7			

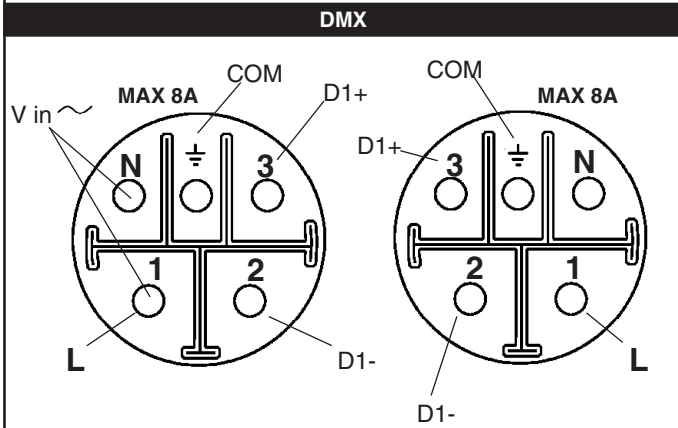
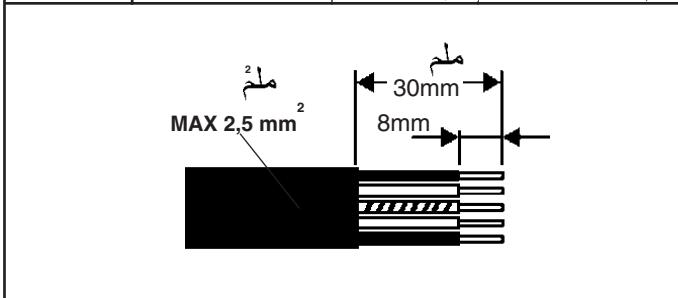

Product version	ADDRESSES n°	ADDRESSES			
		1	2	3	4
Monochrome	1	White			
WNC	3	Warm	Neutral	Cool	
RGB	3	Red	Green	Blue	
WRGB	4	Red	Green	Blue	White
WRGBW	4	Red	Green	Blue	White

تأكد من صحة توصيل الأقطاب قبل إمداد الجهاز بالتيار الكهربائي.
التوصيل غير الصحيح يُمكن أن يتسبب في عدم عمل الأجهزة بشكل صحيح.

I Prima di alimentare l'impianto assicurarsi del corretto collegamento delle polarità.
Un errato collegamento può comportare il malfunzionamento dei prodotti.

GB Before powering the system, make sure polarities were properly connected.
Incorrect connection may cause the product to malfunction.

E Antes de alimentar la instalación compruebe que la conexión de las polaridades sea correcta.
Una conexión incorrecta puede ocasionar el malfuncionamiento de los productos.

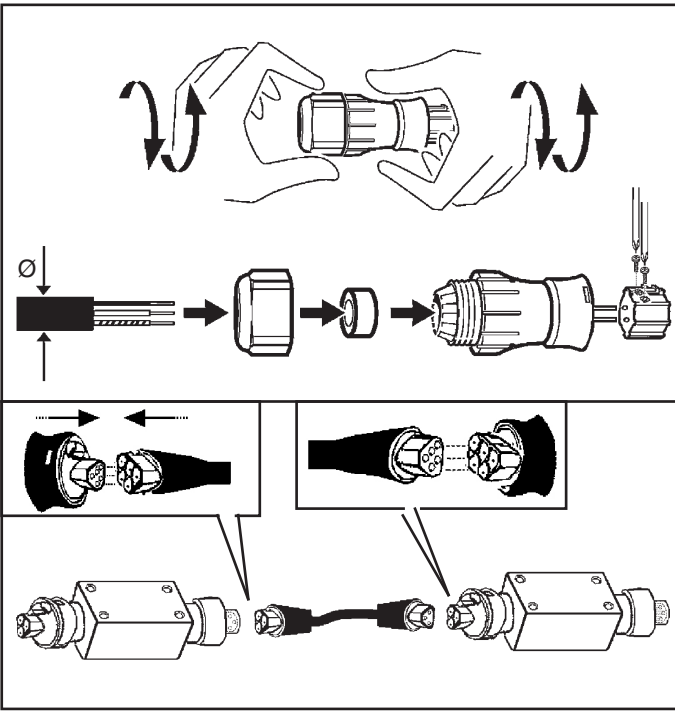

الصفيف ART.	كبل cavo cable cable	ملم (mm) X	ملم (mm) L
BZJ3	ملم ²	430	528
BZJ4	5 x 2,5mm	960	1056
BZJ5	ملم ²	1490	1585
BZT4	ملم ²	374	506
BZT5	5 x 2,5mm	902	998
BZT6	ملم ²	1395	1490
BZW1	ملم ²	408	540
BZW2	5 x 2,5mm	893	1026
BZW3	ملم ²	1378	1511

قم بحساب أقصى عدد من المنتجات التي يمكن توصيلها متتالية، مع الأخذ في الاعتبار القدرة التيار الممتصة من الأجهزة، ومقطع الكابل، وطول الكابلات وأقصى تيار للموصلات. (8A).

I Calcolare il numero massimo dei prodotti collegabili in cascata, tenendo conto dell'assorbimento dei prodotti, della sezione dei cavi, della lunghezza dei cavi e della corrente max dei connettori.

GB Calculate the maximum number of products connectable in cascade based on products' consumption, connectors' maximum current, cables' section and length.

E Calcular el número máximo de productos conectables en cascada, teniendo en cuenta la absorción de los productos, la sección de los cables, la longitud de los cables y la corriente máxima de los conectores.

ملحوظة هامة: لإنهاء خط نظام التحكم في الأضواء الرقمي المتعدد "DMX" ضع في آخر وحدة المنتج BZQ7.

I N.B.: Per chiudere la linea DMX inserire sull'ultimo modulo l'art. BZQ7.

GB N.B.: To close the DMX line, add item BZQ7 onto the last module.

E Nota: Para cerrar la línea DMX introducir en el último módulo el art. BZQ7.

art. BZQ7

art. BZQ7

art. BZI5
BZI6

examples

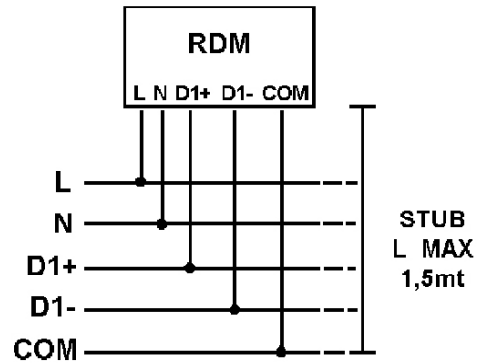
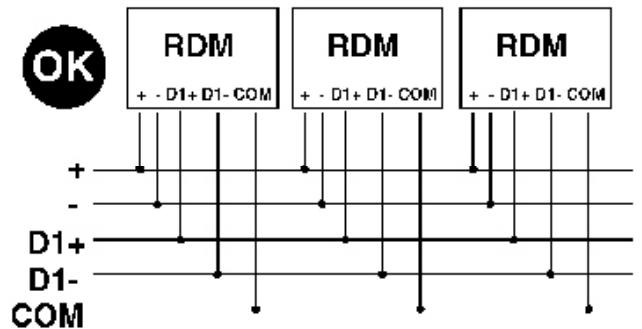

NO DMX

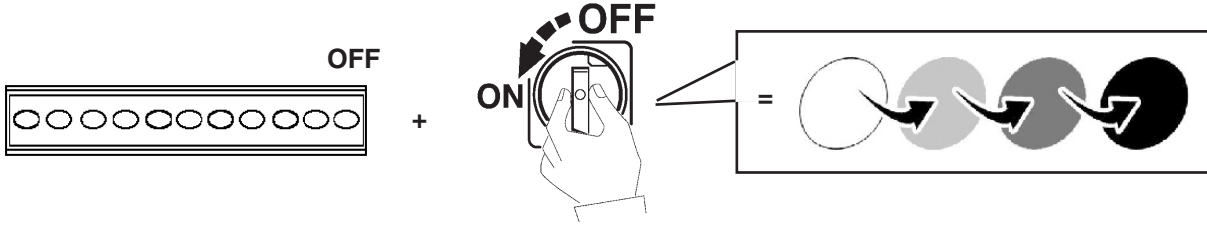

"لا يمكن ضمان تزامن الألوان لمنتجات أخرى تعمل بالطاقة الكهربائية بدون نظام التحكم DMX".

I "NON SI GARANTISCE IL SINCRONISMO DELLA RUOTA COLORI DI PIU' PRODOTTI ALIMENTATI SENZA SISTEMA DI CONTROLLO DMX".

GB "COLOUR WHEEL SYNCHRONISM NOT ENSURED IF SEVERAL PRODUCTS POWERED WITHOUT DMX CONTROL SYSTEM".

E "NO SE GARANTIZA EL SINCRONISMO DE LA VARIACIÓN CROMÁTICA EN CASO DE PRODUCTOS MÚLTIPLES ALIMENTADOS SIN SISTEMA DE CONTROL DMX".

تعامل مع المنتج بعناية وحرص، ولا تُعرضه للإجهادات الميكانيكية

I Maneggiare con cura e non sottoporre a tensioni meccaniche.

GB Handle with care and do not subject to mechanical stress.

E Manejar con cuidado y no someter a tensiones mecánicas.

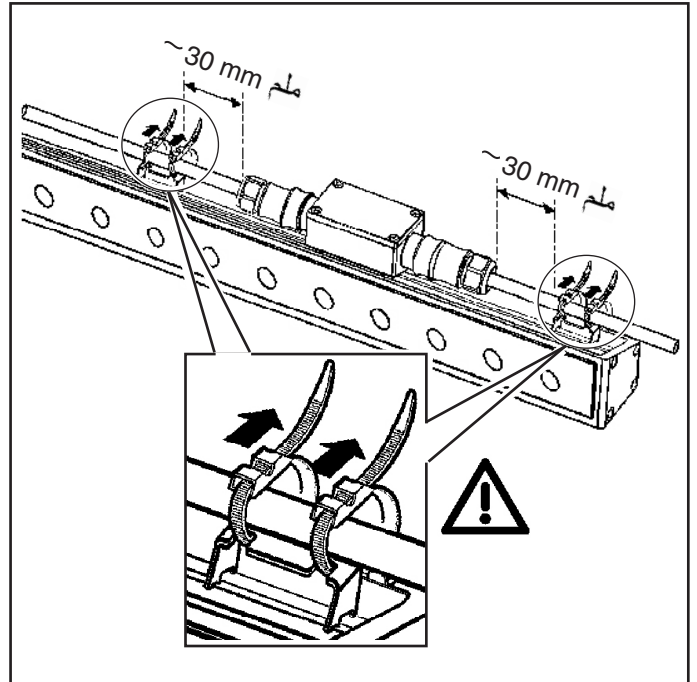
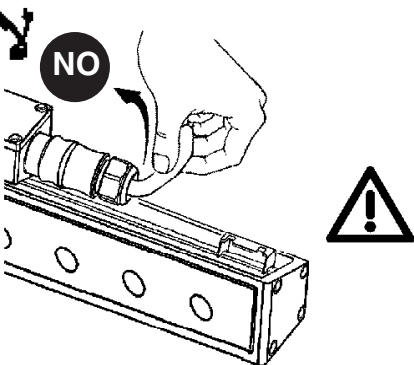
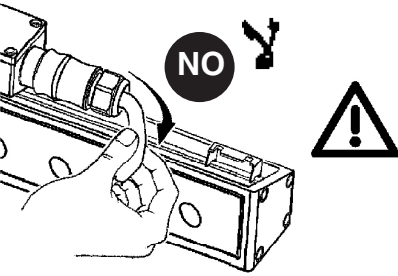
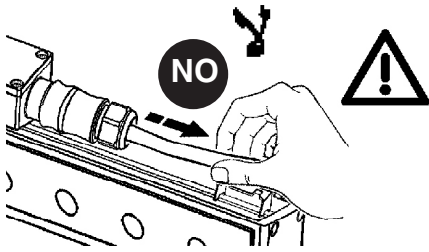

الصفحة art. BZ10 - BZ11
5570 - 5571
5576 - 5577
5578 - BZV9
BZW0
BZX2
BZX3

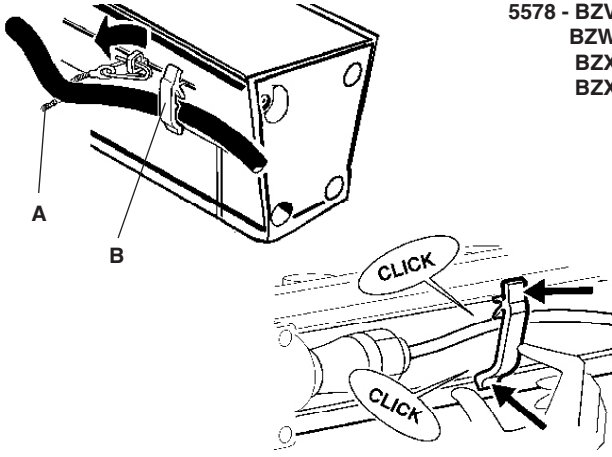

قبل تثبيت الوحدة على الدعامة الميكانيكية، اشبك كبلات فولاد «A» حسب ما هو مبين في الشكل. استخدم المشابك «B» لترتيب الكبلات الكهربائية بشكل تام خلف الوحدة.

I Prima di bloccare il modulo al supporto meccanico, agganciare i cavetti d'acciaio "A" come indicato in figura. Utilizzare le clips "B" per sistemare i cavi elettrici perfettamente dietro al modulo.

GB Before locking the module onto the mechanical support, hook on the steel cables "A" as indicated in the figure. Use the clips "B" to tidy up the electric cables behind the module.

E Antes de fijar el módulo al soporte mecánico, enganchar los cables de acero «A» según ilustrado en la figura. Utilizar las clips «B» para el perfecto alojamiento de los cables en el módulo.



ملاحظة: ملاحظة: أثناء تركيب نظام "LINEALUCE LED". يجب التقيد بحرص بالنظم السائدة المتعلقة بالشبكة الكهربائية.

N.B.: DURANTE L'INSTALLAZIONE DEL SISTEMA RISPETTARE SCRUPolosAMENTE LE NORME IMPIANTISTICHE VIGENTI.

N.B.: WHEN INSTALLING THE SYSTEM, STRICTLY COMPLY WITH ALL REGULATIONS ON INSTALLATION IN FORCE.

N.B.: DURANTE LA INSTALACIÓN DEL SISTEMA RESPETAR E SCRUPolosAMENTE LAS NORMAS DE INSTALACIÓN VIGENTES.

تنبيه: لاستبدال الضوء LED اتصل بشركة iGuzzini .

I N.B.: Per la sostituzione del LED contattare l'azienda iGuzzini.

GB N.B.: For information on LED replacement please contact iGuzzini.

E NOTA: Para sustituir el LED llame a la empresa iGuzzini.

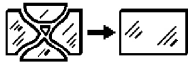

لا يمكن استخدام هذا المنتج في حالة وجود كسر في العدسات، ومن ثم يجب الاتصال بالشركة المصنعة لاستبدال العدسات المكسورة.

I In caso di rottura delle lenti il prodotto non può essere utilizzato, contattare il costruttore per la sua sostituzione.

GB Should the lenses break, the product cannot be used. Contact the manufacturer for replacement.

E En caso de rotura de las lentes, el producto no puede utilizarse y se debe contactar con el fabricante para su sustitución.

art. BZH7 - BZH8 - BZH9 - BZT1 - BZT2 - BZT3
BZV6 - BZV7 - BZV8

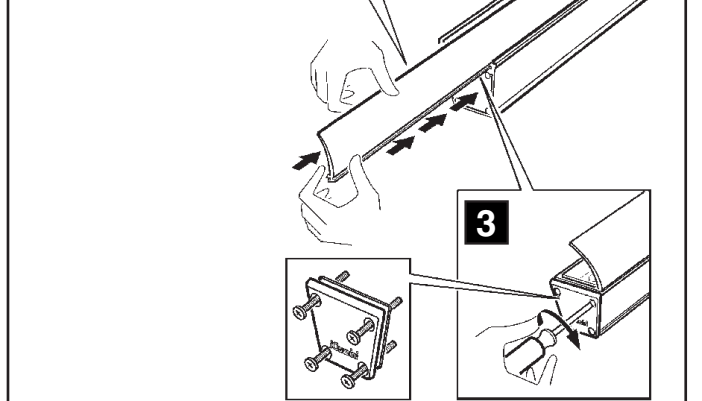
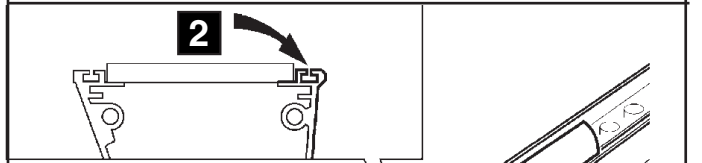
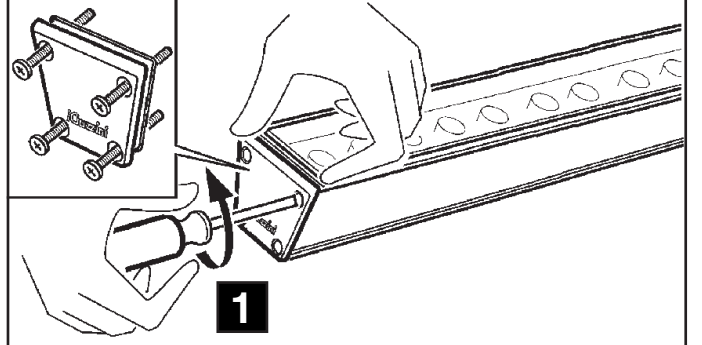
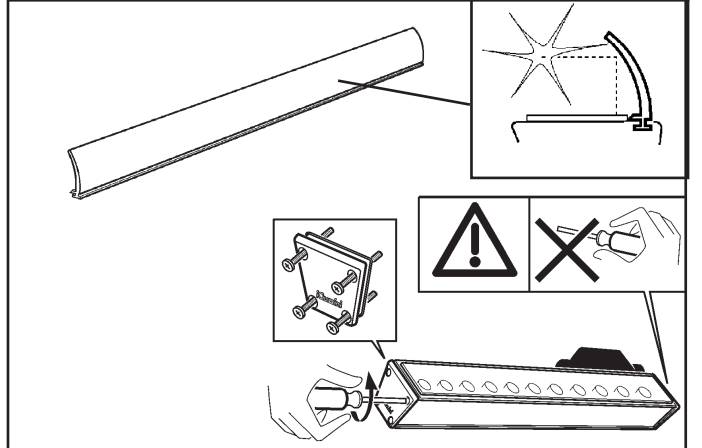

الصفحة ART.	BZW8	BZW9
BP12 - BP14	●	/
BP13 - BP15	/	●

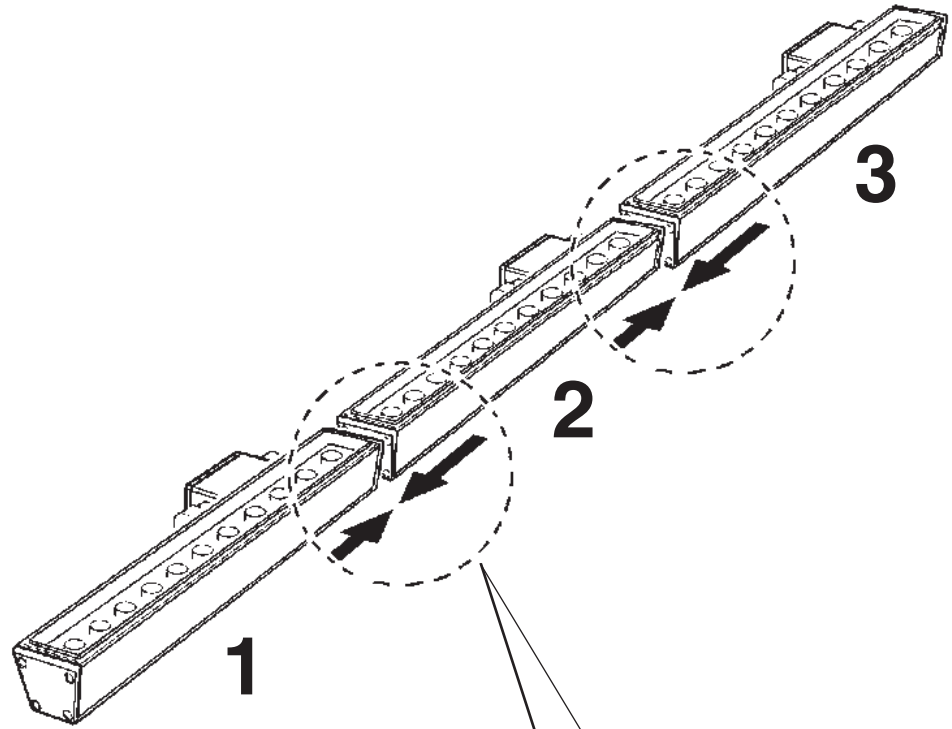

+

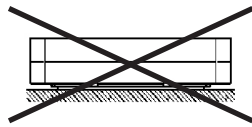

+

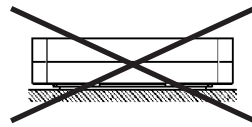

+

...

NO



1

WRGB W

art. BN90 - BN91 - BN92

2

WRGB W

art. BN90 - BN91 - BN92

3

WRGB W

art. BN90 - BN91 - BN92

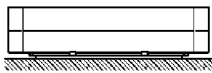

+



+



+

...

OK



1

WRGB W

art. BN90 - BN91 - BN92

2

RGB W

art. BN90 - BN91 - BN92

3

RGB W

art. BN90 - BN91 - BN92

I PERIODO GIORNALIERO DI ACCENSIONE AMMESSO

iGuzzini

1.154.627.01
IS09175/01

GB ALLOWED DAILY OPERATION PERIOD

F DURÉE QUOTIDIENNE D'ALLUMAGE ADMISSIBLE

D ERLAUBTE TÄGLICHE EINSCHALTDAUER

NL DAGELIJKSE ONTSTEKINGSPERIODE TOEGESTAAN

E PERIODO DIARIO DE ENCENDIDO PERMITIDO

DK TILLADT TIDSRUM FOR DAGLIG TÆNDING

N TILLÄTT TENNINGSTID PR. DAG

S TILLÄTEN DAGLIG PERIOD SOM PRODUKTEN KAN VARA TÄND

RUS ЕЖЕДНЕВНАЯ ДОПУСТИМАЯ ПРОДОЛЖИТЕЛЬНОСТЬ РАБОТЫ

CN 允许的日常运营周期

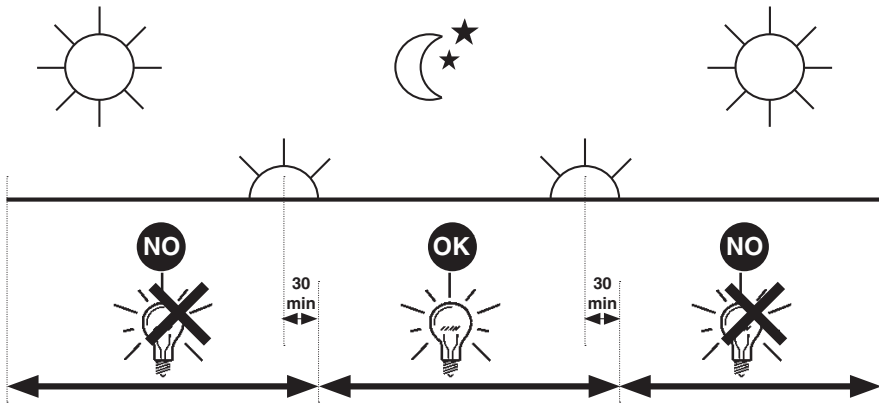

I PERIODO GIORNALIERO DI ACCENSIONE AMMESSO

iGuzzini

1.154.627.01
IS09175/01

GB ALLOWED DAILY OPERATION PERIOD

F DURÉE QUOTIDIENNE D'ALLUMAGE ADMISSIBLE

D ERLAUBTE TÄGLICHE EINSCHALTDAUER

NL DAGELIJKSE ONTSTEKINGSPERIODE TOEGESTAAN

E PERIODO DIARIO DE ENCENDIDO PERMITIDO

DK TILLADT TIDSRUM FOR DAGLIG TÆNDING

N TILLÄTT TENNINGSTID PR. DAG

S TILLÄTEN DAGLIG PERIOD SOM PRODUKTEN KAN VARA TÄND

RUS ЕЖЕДНЕВНАЯ ДОПУСТИМАЯ ПРОДОЛЖИТЕЛЬНОСТЬ РАБОТЫ

CN 允许的日常运营周期

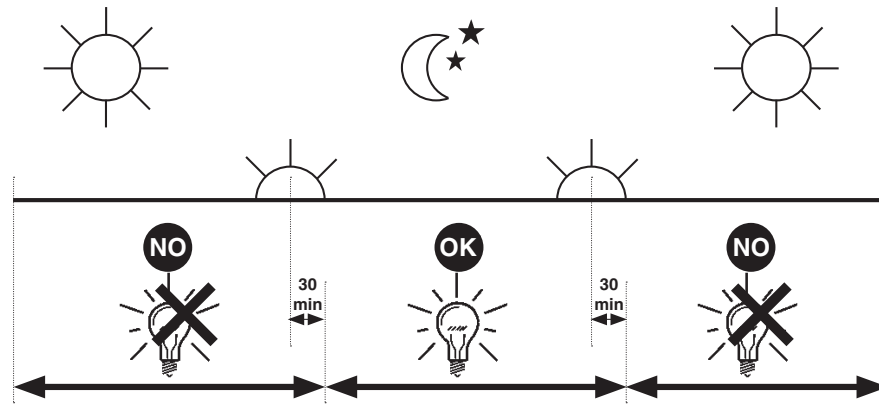

I PERIODO GIORNALIERO DI ACCENSIONE AMMESSO

iGuzzini

1.154.627.01
IS09175/01

GB ALLOWED DAILY OPERATION PERIOD

F DURÉE QUOTIDIENNE D'ALLUMAGE ADMISSIBLE

D ERLAUBTE TÄGLICHE EINSCHALTDAUER

NL DAGELIJKSE ONTSTEKINGSPERIODE TOEGESTAAN

E PERIODO DIARIO DE ENCENDIDO PERMITIDO

DK TILLADT TIDSRUM FOR DAGLIG TÆNDING

N TILLÄTT TENNINGSTID PR. DAG

S TILLÄTEN DAGLIG PERIOD SOM PRODUKTEN KAN VARA TÄND

RUS ЕЖЕДНЕВНАЯ ДОПУСТИМАЯ ПРОДОЛЖИТЕЛЬНОСТЬ РАБОТЫ

CN 允许的日常运营周期

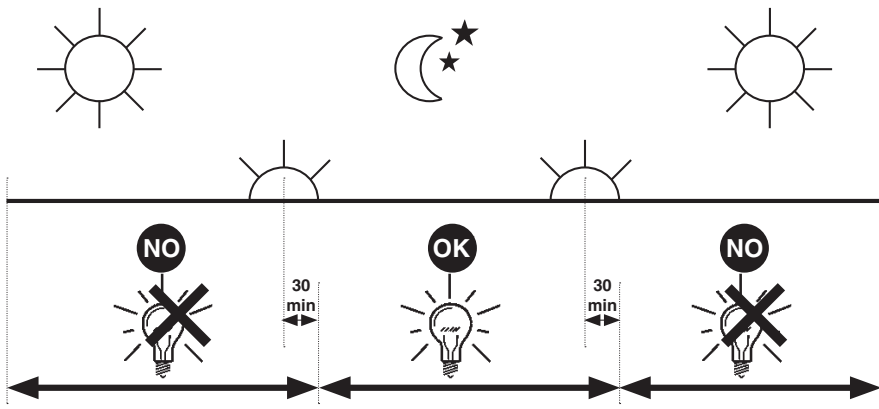

I PERIODO GIORNALIERO DI ACCENSIONE AMMESSO

iGuzzini

1.154.627.01
IS09175/01

GB ALLOWED DAILY OPERATION PERIOD

F DURÉE QUOTIDIENNE D'ALLUMAGE ADMISSIBLE

D ERLAUBTE TÄGLICHE EINSCHALTDAUER

NL DAGELIJKSE ONTSTEKINGSPERIODE TOEGESTAAN

E PERIODO DIARIO DE ENCENDIDO PERMITIDO

DK TILLADT TIDSRUM FOR DAGLIG TÆNDING

N TILLÄTT TENNINGSTID PR. DAG

S TILLÄTEN DAGLIG PERIOD SOM PRODUKTEN KAN VARA TÄND

RUS ЕЖЕДНЕВНАЯ ДОПУСТИМАЯ ПРОДОЛЖИТЕЛЬНОСТЬ РАБОТЫ

CN 允许的日常运营周期

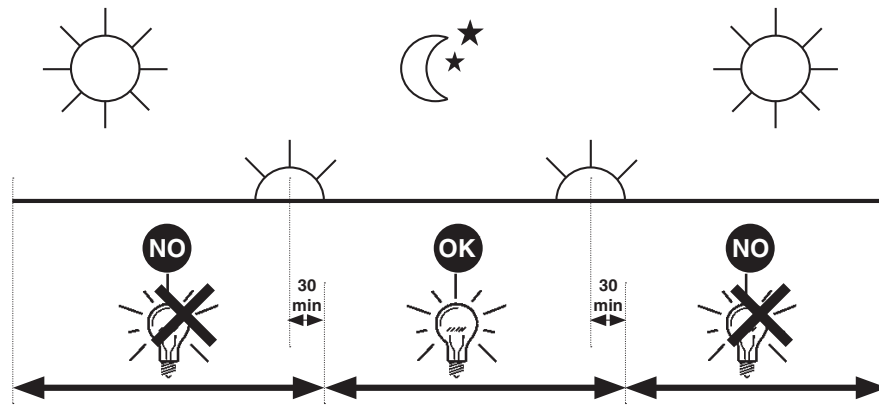

iGuzzini 2.519.534.02 IS07064/02	fattore di potenza power factor facteur de puissance Leistungsfaktor vermogensfactor factor de potencia effektfaktor effektfaktor effektfaktor фактор мощности 功率因数	corrente assorbita absorbed current courant absorbé Stromaufnahme stroomopname corriente absorbida absorberet strøm absorbert strøm tillförd ström поглощаемая мощность 电源电流 (A)
ART		
BG96	>0,9	0,040
BG97		
BG98		
BG99	>0,9	0,080
BH00		
BH01		
BH02	>0,9	0,110
BH03		
BH04		
BH05	>0,9	0,070
BH06		
BH07		
BH08	>0,9	0,130
BH09		
BI51		
BI52	>0,95	0,190
BH10		
BH11		
BI53	>0,95	0,09
BI54		
BH12		
BH13	>0,95	0,180
BI55		
BI56		
BI57 - BI58 - BI63 - BI64	>0,95	0,300
BI59 - BI60 - BI65 - BI66		
BI61 - BI62 - BI67 - BI68 - BN91 - BN88		
BI69 - BI72 - BP12 - BP14 - BM63 - BM66	>0,9	0,114
BI70 - BI73 - BP13 - BP15 - BM64 - BM67		
BI71 - BI74 - BM65 - BM68		
BM42 - BM45	>0,9	0,170
BM43 - BM46		
BM44 - BM47		
BN87 - BN90	>0,95	0,217
BN89 - BN92		
	-	-
	-	-

iGuzzini 2.519.534.02 IS07064/02	fattore di potenza power factor facteur de puissance Leistungsfaktor vermogensfactor factor de potencia effektfaktor effektfaktor effektfaktor фактор мощности 功率因数	corrente assorbita absorbed current courant absorbé Stromaufnahme stroomopname corriente absorbida absorberet strøm absorbert strøm tillförd ström поглощаемая мощность 电源电流 (A)
ART		
BG96	>0,9	0,040
BG97		
BG98		
BG99	>0,9	0,080
BH00		
BH01		
BH02	>0,9	0,110
BH03		
BH04		
BH05	>0,9	0,130
BH06		
BH07		
BH08	>0,95	0,190
BH09		
BI51		
BI52	>0,95	0,09
BH10		
BH11		
BI53	>0,95	0,180
BI54		
BH12		
BH13	>0,95	0,300
BI55		
BI56		
BI57 - BI58 - BI63 - BI64	>0,9	0,114
BI59 - BI60 - BI65 - BI66		
BI61 - BI62 - BI67 - BI68 - BN91 - BN88		
BI69 - BI72 - BP12 - BP14 - BM63 - BM66	>0,9	0,133
BI70 - BI73 - BP13 - BP15 - BM64 - BM67		
BI71 - BI74 - BM65 - BM68		
BM42 - BM45	>0,9	0,245
BM43 - BM46		
BM44 - BM47		
BN87 - BN90	>0,95	0,119
BN89 - BN92		
	-	-
	-	-

iGuzzini

2.509.386.00
ISO9176/01

الفترة الزمنية اليومية للتشغيل المسموح بها

- I PERIODO GIORNALIERO DI ACCENSIONE AMMESSO
- GB ALLOWED DAILY OPERATION PERIOD
- E PERIODO DIARIO DE ENCENDIDO PERMITIDO

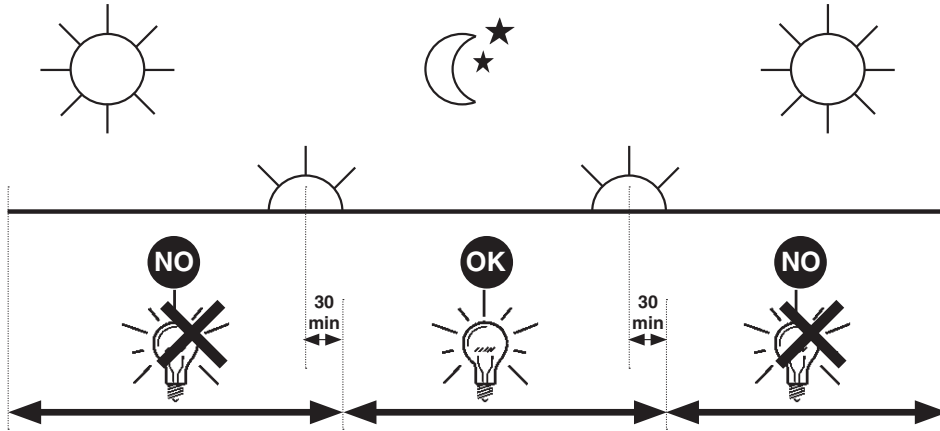

iGuzzini

2.509.386.00
ISO9176/01

الفترة الزمنية اليومية للتشغيل المسموح بها

- I PERIODO GIORNALIERO DI ACCENSIONE AMMESSO
- GB ALLOWED DAILY OPERATION PERIOD
- E PERIODO DIARIO DE ENCENDIDO PERMITIDO

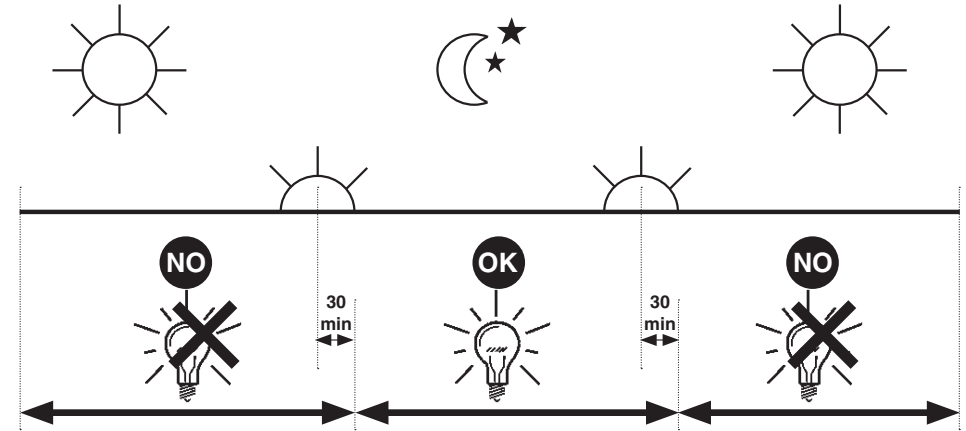

iGuzzini

2.509.386.00
ISO9176/01

الفترة الزمنية اليومية للتشغيل المسموح بها

- I PERIODO GIORNALIERO DI ACCENSIONE AMMESSO
- GB ALLOWED DAILY OPERATION PERIOD
- E PERIODO DIARIO DE ENCENDIDO PERMITIDO

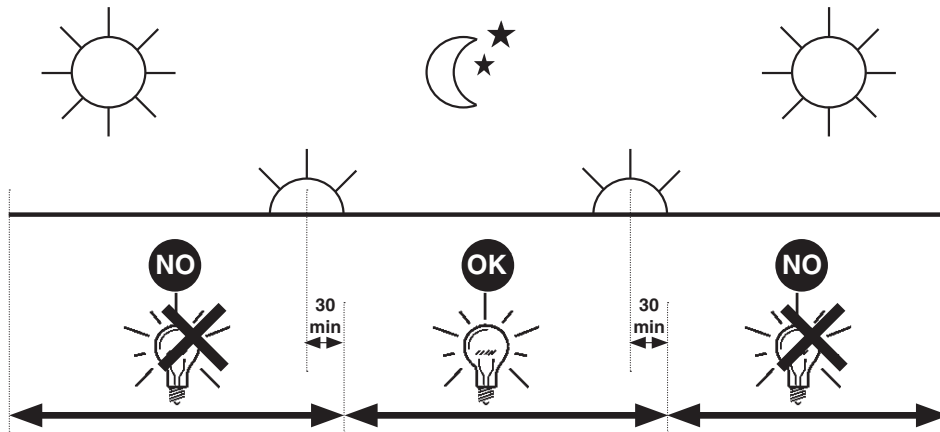

iGuzzini

2.509.386.00
ISO9176/01

الفترة الزمنية اليومية للتشغيل المسموح بها

- I PERIODO GIORNALIERO DI ACCENSIONE AMMESSO
- GB ALLOWED DAILY OPERATION PERIOD
- E PERIODO DIARIO DE ENCENDIDO PERMITIDO

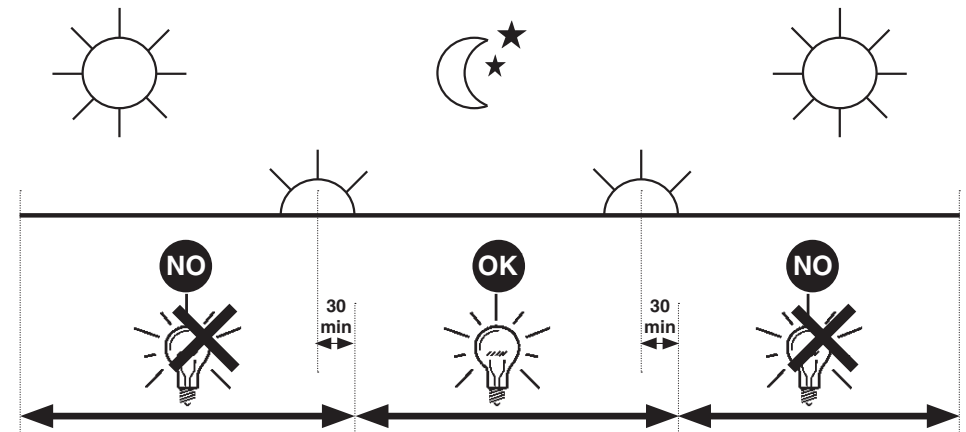

- I Istruzioni per le operazioni di servizio per l'apparecchio di illuminazione**
GB Instructions on luminaire service operations
F Instructions pour les opérations de service du luminaire
D Wartungsanleitung für die Leuchte
NL Instructies voor de onderhoudsoperaties op de verlichtingsarmatuur
E Instrucciones para las operaciones de servicio del aparato de alumbrado
DK Anvisninger i serviceindgreb på belysningsarmatur
N Anvisninger for betjening av lysapparatet
S Instruktioner för användning av belysningsanordningen
RUS Инструкции по эксплуатации осветительного прибора
CN 照明装置检修操作说明

Sostituire la lampada parzialmente esausta
 Replace the partly exhausted lamp
 Remplacer la lampe partiellement épuisée
 Die teilweise erschöpfte Lampe austauschen
 Vervang de gedeeltelijk lege lamp
 Sustituir la lámpara parzialmente agotada
 Udskift den delvist udtjente pære
 Skifte ut den delvis utbrente lyspæren
 Byt ut den delvis förbrukade lampan
 Замена частично отработанной лампочки
 更换部分老化的灯泡

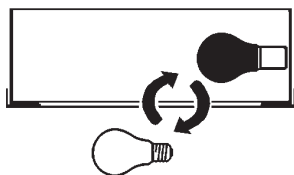

Spegnimento
 Switch it off
 Extinction
 Ausschaltung
 Uitschakeling
 Apagado
 Slukning
 Slukking
 Släckning
 Выключение
 关灯

Interrompere l'alimentazione dell'apparecchio
 Cut the power supply to the luminaire
 Couper l'alimentation du luminaire
 Stromversorgung der Leuchte unterbrechen
 Onderbreek de voeding van het apparaat
 Interrumpir la alimentación del aparato
 Afbryd armaturets strømforsyning
 Avbryte strømtilførselen til apparatet
 Koppla från anordningens strömförsörjning
 Отключить электропитание прибора
 中断装置供电

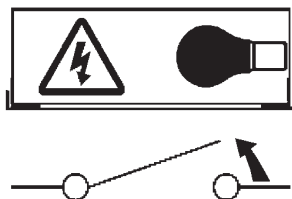

Aprire l'apparecchio
 Open the fixture
 Ouvrir le luminaire
 Das Gerät öffnen
 Open het apparaat
 Abrir el aparato
 Åbn armaturet
 Åpne apparatet
 Öppna anordningen
 Раскрыть прибор
 打开装置

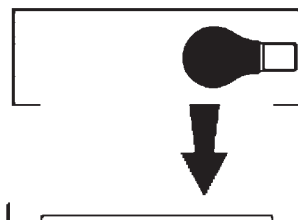

Rimuovere la lampada esausta
 Remove the exhausted lamp
 Retirer la lampe épuisée
 Die alte Lampe entnehmen
 Verwijder de lege lamp
 Quitar la lámpara agotada
 Tag den udtjente pære ud
 Fjerne den utbrente lyspæren
 Ta bort den förbrukade lampan
 Вынуть старую лампочку
 取出老化的灯泡

Portarla in un centro di riciclaggio
 Carry it to a recycling centre
 La porter dans une déchetterie pour son recyclage
 Ordnungsgemäß entsorgen
 Breng de lamp naar een recyclingcentrum
 Llevarla a un centro de reciclaje
 Aflever den på en genbrugsstation
 Lever den til en miljøstasjon
 Lämna in den till en återvinningsanläggning
 Сдать ее в пункт приема утильсырья
 将其送往回收中心

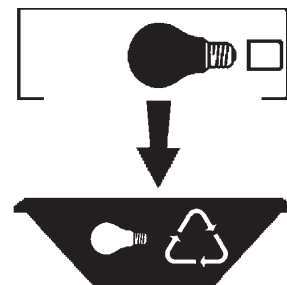

Inserire la nuova lampada
 Introduce the new lamp
 Installer la lampe neuve
 Die neue Lampe einsetzen
 Doe de nieuwe lamp op zijn plek
 Montar la nueva lámpara
 Sæt den nye pære i
 Sette i den nye pæren
 Sätt i den nya lampan
 Вставить новую лампочку
 装入新灯泡

Inserire la nuova lampada nel portalampana
 Fit the new lamp into the socket
 Installer la nouvelle lampe dans le support de lampe
 Die neue Lampe in den Sockel einsetzen
 Doe de nieuwe lamp in de lamphouder
 Montar la nueva lámpara en el portalampana
 Sæt den nye pære i fatningen
 Sette den nye pæren inn i lampeholderen
 Sätt i den nya lampan i lamphållaren
 Вставить новую лампочку в патрон
 将新灯泡插入灯泡架中

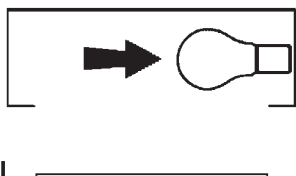

Riposizionare ottica
 Re-place the optic
 Remettre l'optique à sa place
 Die Optik wieder einsetzen
 Doe de optiek weer op zijn plaats
 Volver a montar la óptica
 Sæt den optiske enhed på plads
 Innstille linsen
 Flytta om optiken
 Отрегулировать линзы
 重新定位光头

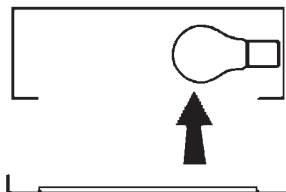

Effettuare prova di funzionamento
 Perform operative test
 Procéder à un essai de fonctionnement
 Eine Funktionsprüfung durchführen
 Controleer de correcte werking
 Hacer una prueba de funcionamiento
 Afprøv funktionen
 Prøve om den fungerer
 Utför funktionstest
 Выполнить проверку исправности работы
 执行功能测试

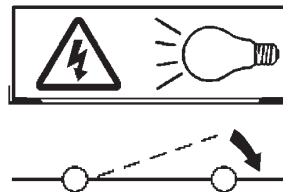

I Istruzioni per la pulizia dell'apparecchio di illuminazione
GB Instructions on luminaire cleaning operations
F Instructions pour le nettoyage du luminaire
D Anweisungen zur Reinigung der Leuchte
NL Instructies voor de reiniging van de verlichtingsarmatuur
E Instrucciones para limpiar el aparato de alumbrado
DK Anvisninger i rengøring af belysningsarmaturet
N Anvisninger for rengjøring av lysapparatet
S Instruktioner för rengöring av belysningsanordningen
RUS Инструкции по чистке осветительного прибора
CN 照明装置清洁说明

Pulire l'apparecchio
Clean the fixture
Nettoyer le luminaire
Das Gerät reinigen
Reinig het apparaat
Limpiar el aparato
Rengør armaturet
Rengjøre apparatet
Rengör anordningen
Чистка прибора
清洁装置



Spegnimento
Switch it off
Extinction
Ausschaltung
Uitschakeling
Apagado
Slukning
Slukking
Släckning
Выключение
关灯

Interrompere l'alimentazione dell'apparecchio
Cut the power supply to the luminaire
Couper l'alimentation du luminaire
Stromversorgung der Leuchte unterbrechen
Onderbreek de voeding van het apparaat
Interrumpir la alimentación del aparato
Afbryd armaturets strømforstyrning
Avbryt strømtilførselen til apparatet
Koppla från anordningens strömförsörjning
Отключить электропитание прибора
中断装置供电



Spolverare l'ottica esterna
Remove dust from the external optic
Dépoussiérer l'optique extérieure
Die externe Optik abstauben
Stof de externe optiek af
Quitar el polvo de la óptica exterior
Tør støvet af den udvendige optiske enhed
Fjerne støv fra den eksterne lysenheden
Damma av den yttre optiken
Вытереть пыль с внешней стороны линз
为外侧光头掸尘



Lavare l'ottica esterna
Wash the external optic
Laver l'optique extérieure
Die externe Optik waschen
Was de externe optiek
Lavar la óptica exterior
Vask den udvendige optiske enhed
Vaske den eksterne lysenheden
Rengör den yttre optiken
Вымыть линзы с внешней стороны
清洁外光头



Rimuovere l'ottica
Remove the optic
Retirer l'optique
Die Optik abnehmen
Verwijder de optiek
Quitar la óptica
Tag den optiske enhed af
Fjerne lysenheden
Ta bort optiken
Снять линзы
取下光头



Pulire la parte interna dell'apparecchio di illuminazione
Clean the inside of the fixture
Nettoyer l'intérieur du luminaire
Die Innenseite der Leuchte reinigen
Reinig de binnenzijde van de verlichtingsarmatuur
Limpiar el interior del aparato de alumbrado
Rengør belysningsarmaturets indvendige dele
Rengjøre lysapparatet innvendig
Rengör belysningsanordningen invändigt
Протереть осветительный прибор изнутри
清洁照明装置内部



Riposizionare ottica
Re-place the optic
Remettre l'optique à sa place
Die Optik wieder einsetzen
Doe de optiek weer op zijn plaats
Volver a montar la óptica
Sæt den optiske enhed på plads
Innstille linsen
Flytta om optiken
Отрегулировать линзы
重新定位光头



Effettuare prova di funzionamento
Perform operative test
Procéder à un essai de fonctionnement
Eine Funktionsprüfung durchführen
Controleer de correcte werking
Hacer una prueba de funcionamiento
Afprøv funktionen
Prøve om den fungerer
Utför funktionstest
Выполнить проверку исправности работы
执行功能测试

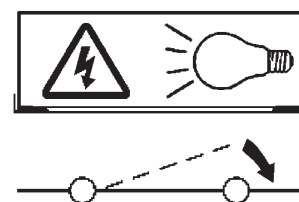

- I** Istruzioni per il fine vita e lo smaltimento dei componenti
GB Instructions on end-of-life and component disposal
F Instructions pour la gestion des composants en fin de vie et leur mise au rebut
D Anweisungen zur Entsorgung der Leuchtenkomponenten
NL Instructies voor het verwijderen van de armatuur en het recyclen van de onderdelen
E Instrucciones para el final de vida y la eliminación los componentes
DK Anvisninger i udtjent armatur og bortskaffelse af komponenter
N Anvisninger for endt levetid og avfallsbehandling av delene
S Instruktioner vid bortskaffning och kassering av komponenter
RUS Инструкции по утилизации прибора и его комплектующих по окончании его срока службы
CN 寿命期结束与零件废弃处置说明

<p>Spegnimento Switch it off Extinction Ausschaltung Uitschakeling Apagado Slukning Slukking Släckning Выключение 关灯</p> <p>Interrompere l'alimentazione dell'apparecchio Cut the power supply to the luminaire Couper l'alimentation du luminaire Stromversorgung der Leuchte unterbrechen Onderbreek de voeding van het apparaat Interrompirla alimentación del aparato Afbryd armaturets strømforsyning Avbryt strømtilførselen til apparatet Koppla från anordningens strömförsörjning Отключить электропитание прибора 中断装置供电</p> 	<p>Rimuovere la/e lampada/e per la dismissione Remove the lamp(s) for decommissioning Retirer la(les) lampe(s) pour sa(leur) mise au rebut Die Lampe/n ordnungsgemäß entsorgen Verwijder de lamp(en) voor het recyclen Quitar la(s) lámpara(s) para el desecho Tag pæren/pærerne ud til bortskaffelse Fjerne lampen/-e som skal kastes Ta bort lampan/-orna för bortskaffningen Вынуть лампочку/и для утилизации прибора 取出需要丢弃的灯泡</p> 	<p>Rimuovere la batteria per la dismissione Remove the battery for decommissioning Retirer la batterie pour sa mise au rebut Die Batterie ordnungsgemäß entsorgen Verwijder de batterij voor het recyclen Quitar la batería para el desecho Tag batteriet ud til bortskaffelse Fjerne batteriet som skal kastes Ta bort batteriet för bortskaffningen Вынуть батарейку для утилизации прибора 取出需要丢弃的电池</p> 	<p>Rimuovere l'apparecchio per la dismissione Remove the fixture for decommissioning Enlever le luminaire pour sa mise au rebut Das Gerät ordnungsgemäß entsorgen Verwijder het apparaat voor het recyclen Quitar el aparato para el desecho Tag armaturet ud til bortskaffelse Fjerne apparatet som skal kastes Ta bort anordningen för bortskaffningen Снять прибор для утилизации 取出需要丢弃的装置</p> 
---	--	--	--

<p>Inviare i materiali ad un centro di raccolta RAEE Send the materials to a WEEE collection centre Envoyer les matériaux dans une déchetterie DEEE Die Materialien in einem WEEE-Zentrum entsorgen Zend de materialen naar een recyclingscentrum voor de AEEA Enviar los materiales a un centro de recogida RAEE Afløver materialerne på et indsamlingscenter for elektronisk udstyr Sende materialene til en miljøstasjon for resirkulering av EE-avfall Skicka materialet till en RAEE uppsamlingscentral Сдать материалы в пункт приема утильсырья 将材料送往电气和电子垃圾回收中心</p> 			
--	--	--	--