

LINEALUCE COMPACT 75 MONOCHROME

ATTENZIONE:

LA SICUREZZA DELL'APPARECCHIO E' GARANTITA SOLO CON L'USO APPROPRIATO DELLE SEGUENTI ISTRUZIONI; PERTANTO E' NECESSARIO CONSERVARLE.

WARNING:

THE SAFETY OF THIS FIXTURE IS GUARANTEED ONLY IF YOU COMPLY WITH THESE INSTRUCTIONS; REMEMBER TO CONSERVE IN A SAFE PLACE.

ATTENTION:

LA SECURITE DE L'APPAREIL N'EST GARANTIE QU'EN CAS D'UTILISATION CORRECTE DES INSTRUCTIONS SUIVANTES; IL FAUT PAR CONSEQUENT LES CONSERVER.

ACHTUNG:

DIE SICHERHEIT DES GERÄTES WIRD NUR DURCH SACHGEMÄSSE BEFOLGUNG NACHSTEHENDER ANWEISUNGEN GEWÄHRLEISTET; IHRE AUFBEWAHRUNG IST DESHALB SEHR WICHTIG.

OPGELET:

DE VEILIGHEID VAN DI ATOESTEL IS SLECHTS DAN GEGARANDEERD ALS INDIEN DE VOLGENDE INSTRUCTIES STRIKT WORDEN TOEGEPAST; DAAROM MOET MEN ZE OOK BEWAREN.

ATENCION:

LA SEGURIDAD DEL APARATO SE GARANTIZA SOLO CUMPLIENDO CUIDADOSAMENTE LAS SIGUIENTES INSTRUCCIONES; POR ELLO, ES NECESARIO CONSERVARLAS.

BEMÆRK:

SIKKERHEDEN VED BRUG AF ARMATURET KAN KUN GARANTERES, HVIS DISSE ANVISNINGER FØLGES; SØRG DERFOR FOR AT GEMME DEM.

ADVARSEL:

SIKKERHETENTIL DETTE APPARATET GARANTERES KUN HVIS DU OVERHOLDER DISSE INSTRUKSJONENE; HUSK Å OPPBEVARE DEM PÅ ET TRYGT STED.

OBSERVERA!

UTRUSTNINGENS SÄKERHET KAN ENDAST GARANTERAS OM DESSA ANVISNINGAR RESPEKTERAS I DETALJ. SPARA DÄRFÖR DESSA ANVISNINGAR FÖR FRAMTIDA KONSULTATION.

ВНИМАНИЕ:

МЫ ГАРАНТИРУЕМ БЕЗОПАСНУЮ ЭКСПЛУАТАЦИЮ ИЗДЕЛИЯ ТОЛЬКО ПРИ СОБЛЮДЕНИИ СЛЕДУЮЩИХ ИНСТРУКЦИЙ; С ЭТОЙ ЦЕЛЬЮ НЕОБХОДИМО СОХРАНИТЬ ДАННУЮ БРОШЮРУ.

警告

为确保该装置安全，请遵守操作指示；并于安全场所放置。

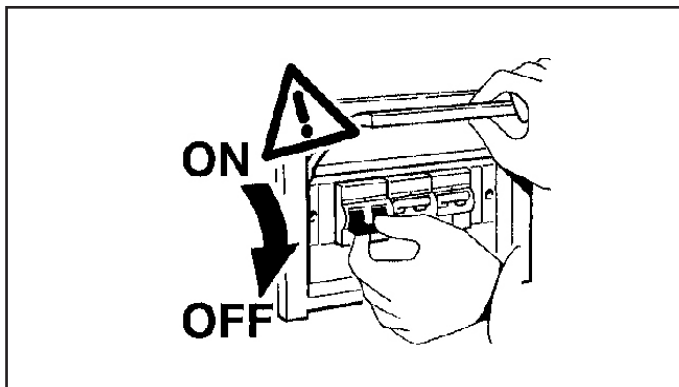
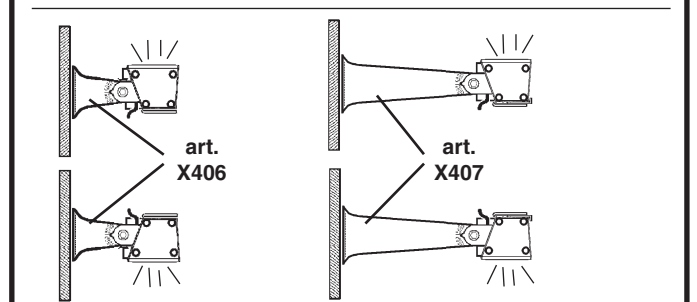
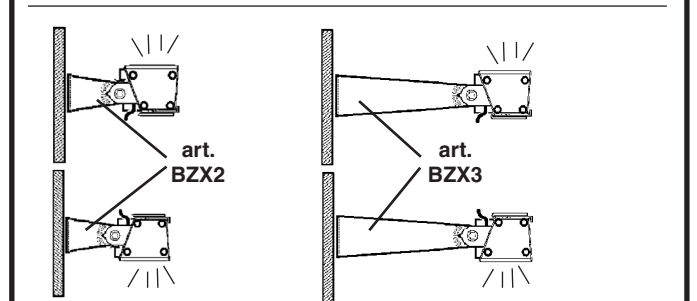
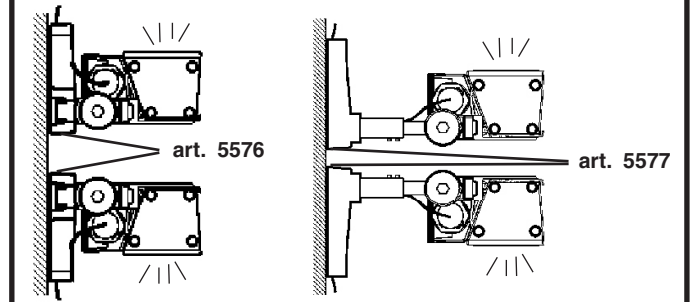
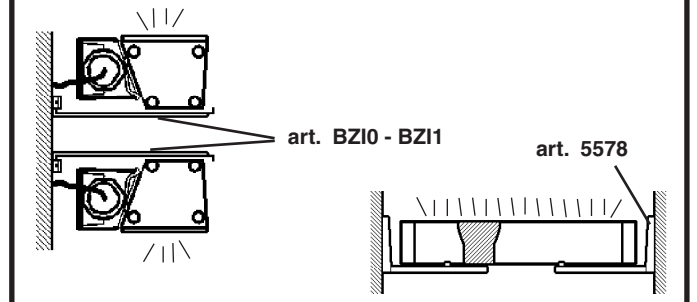
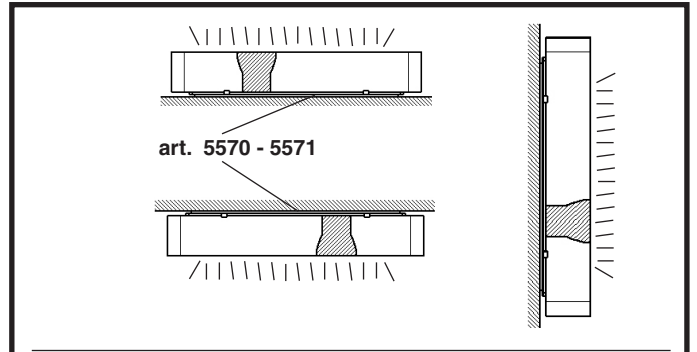
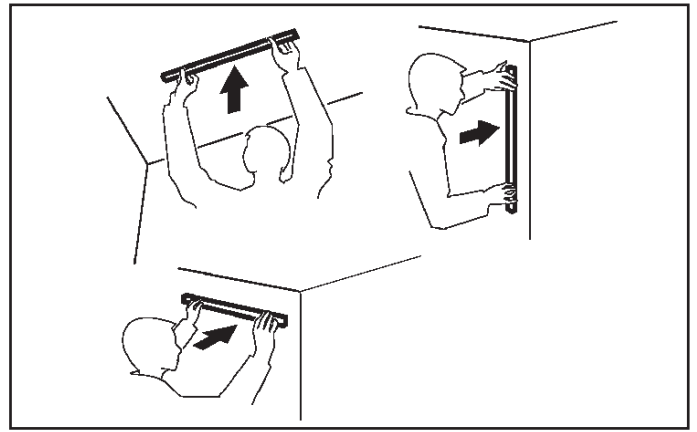

ART.	L	
	(mm)	
BG96 - BG97 - BH02 - BH03 BH08 - BH09 - BI51 - BI52	528	
BG98 - BG99 - BH04 - BH05 BH10 - BH11 - BI53 - BI54	1056	
BH00 - BH01 - BH06 - BH07 BH12 - BH13 - BI55 - BI56	1585	

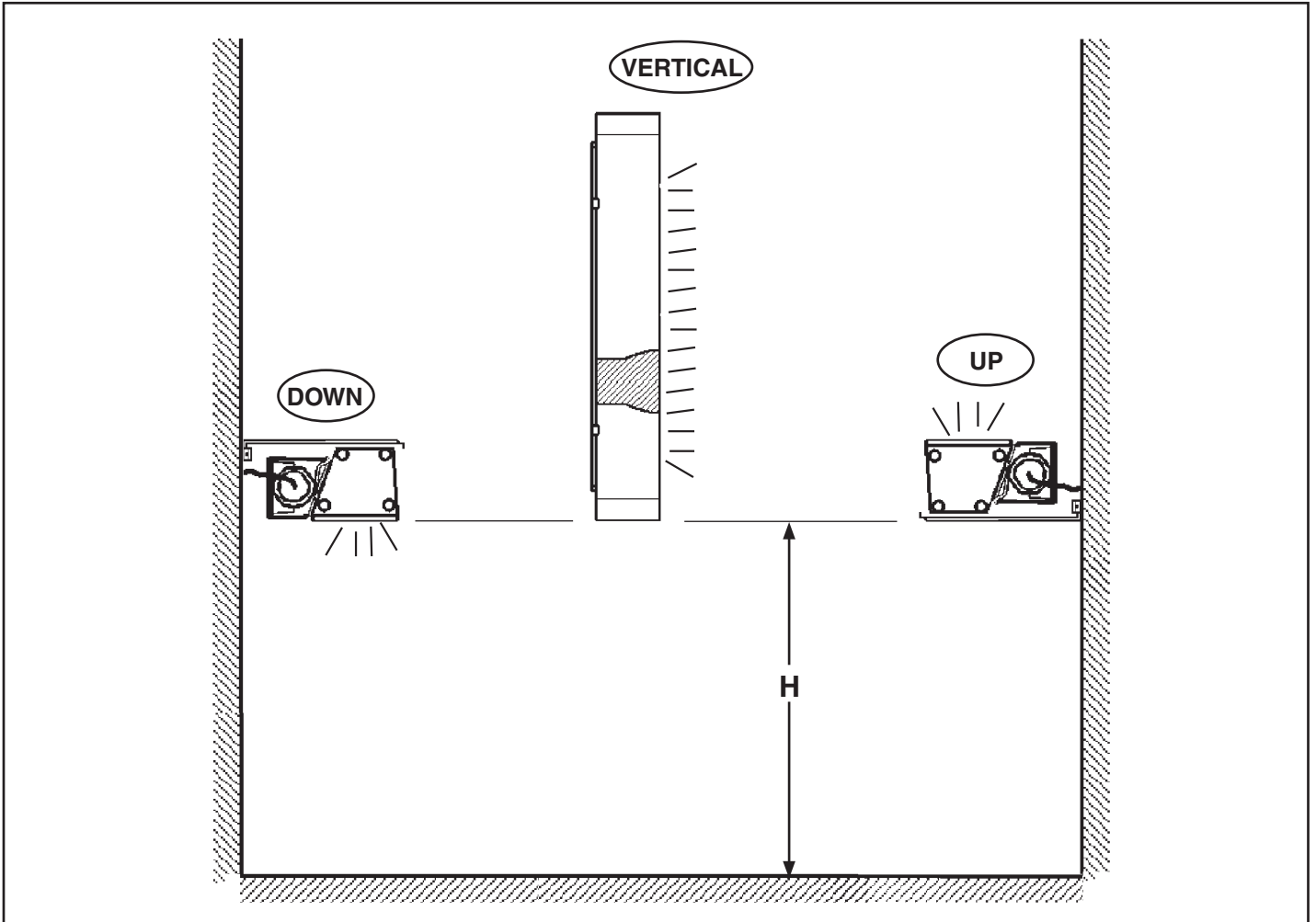

ACCESSORIES		H > 3m			H < 3m		
		UP	DOWN	VERTICAL	UP	DOWN	VERTICAL
	5570 - 5571	✓	✗	✗	✓	✓	✓
	5578	✓	✗	✗	✓	✗	✗
	BZIO - BZI1	✓	✗	✗	✓	✓	✗
	5576 - 5577	✓	✗	✗	✓	✓	✗
	BZX2 - BZX3	✓	✗	✗	✓	✓	✗
	X406 - X407	✓	✓	✗	✓	✓	✗

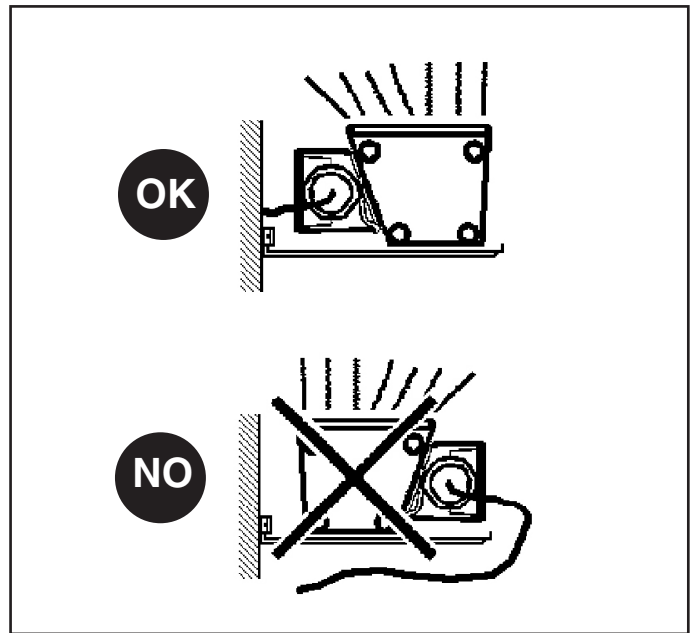
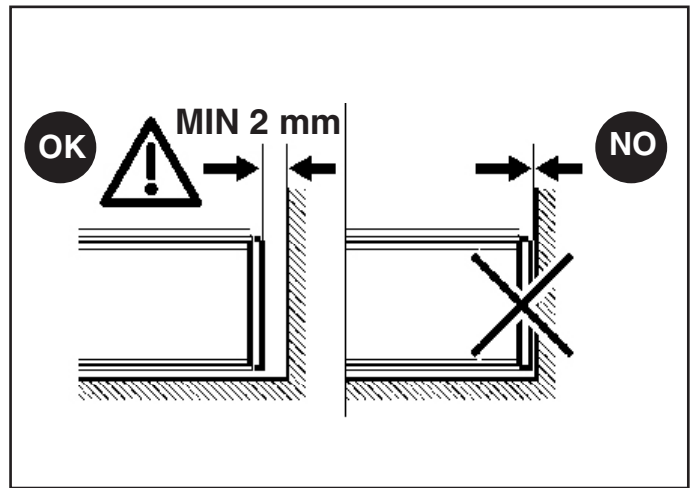
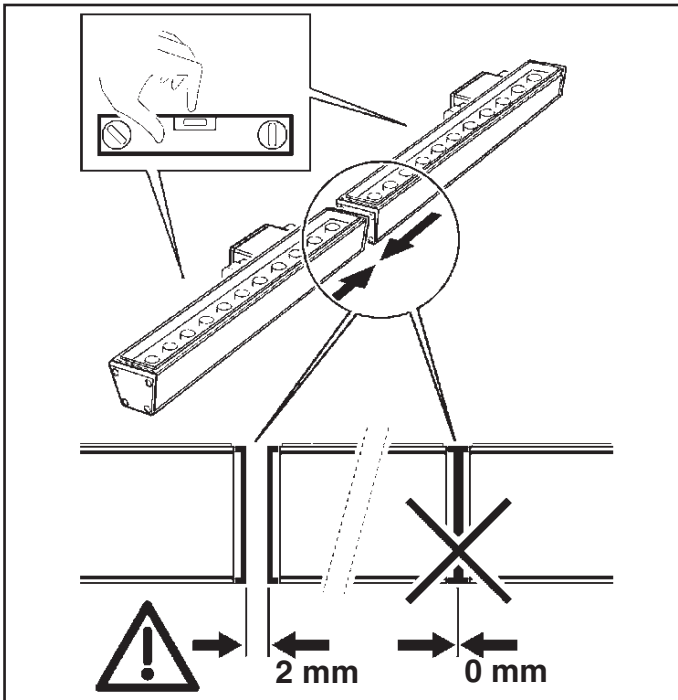
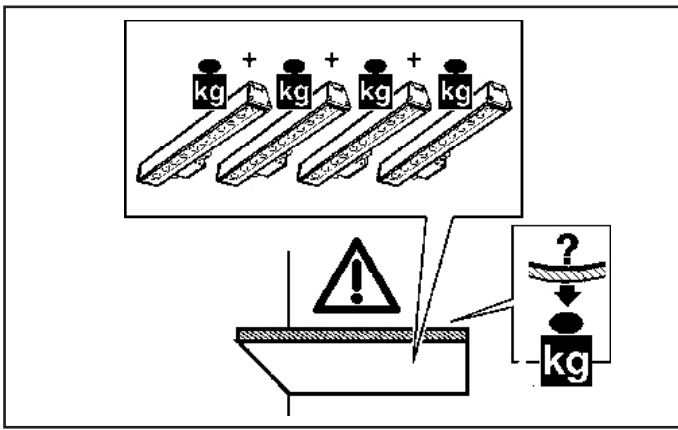

INSTALLAZIONE DEI SUPPORTI MECCANICI - INSTALLATION OF THE MECHANICAL SUPPORTS - INSTALLATION DES SUPPORTS MECANQUES
 BEFESTIGUNG DER HALTEVORRICHTUNGEN - HET INSTALLEREN VAN DE MECHANISCHE STEUNEN - INSTALACIÓN DE LOS SOPORTES MECÁNICOS
 INSTALLATION AF MEKANISKE HOLDERE - INSTALLASJON AV DE MEKANISKE STØTTENE - INSTALLATION AV METALLHÅLLARE
 МОНТАЖ МЕХАНИЧЕСКИХ КРЕПЛЕНИЙ - 机械支架的安装

TABELLA INTERASSI DI FORATURA - TABLE OF CENTRE TO CENTRE DISTANCES OF HOLING
 TABLEAU DES ESPACEMENT DE PERCAGE - TABELLE DER BOHR - MITTENABSTÄNDE
 TABEL VAN DE AFSTAND TUSSEN DE ASSEN VAN DE GATEN - TABLA INTER - EJES DE PERFORACION
 TABEL OVER HULAFSTAND - TABELL OVER AVSTANDER PÅ HULLING SENTER TIL SENTER
 TABELL FÖR HÅLDELNING - ТАБЛИЦА ШАГОВ ОТВЕРСТИЙ - 面板孔的中心距离

L (mm)	ART.	BZ10	BZ11	5570 5571	BZX2 BZX3 X406 X407	5576 5577	BZX2 BZX3 X406 X407 5576 5577	5578
		K(mm)	K(mm)	K(mm)	K(mm)	K(mm)	Y(mm)	K(mm)
528	BG96 - BG97 - BH02 - BH03 - BH08 - BH09 - BI51 - BI52	240	-	265	396	440	-	600 ÷ 900
1056	BG98 - BG99 - BH04 - BH05 - BH10 - BH11 - BI53 - BI54	240	600	265	924	970	-	1094 ÷ 1474
1585	BH00 - BH01 - BH06 - BH07 - BH12 - BH13 - BI55 - BI56	240	600	600	1453	1500	750	1622 ÷ 2002

ART. 5576 - 5577 - BZX2 - BZX3 - X406 - X407

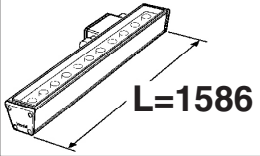

NO

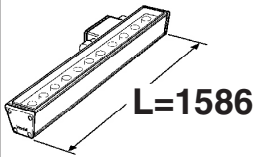
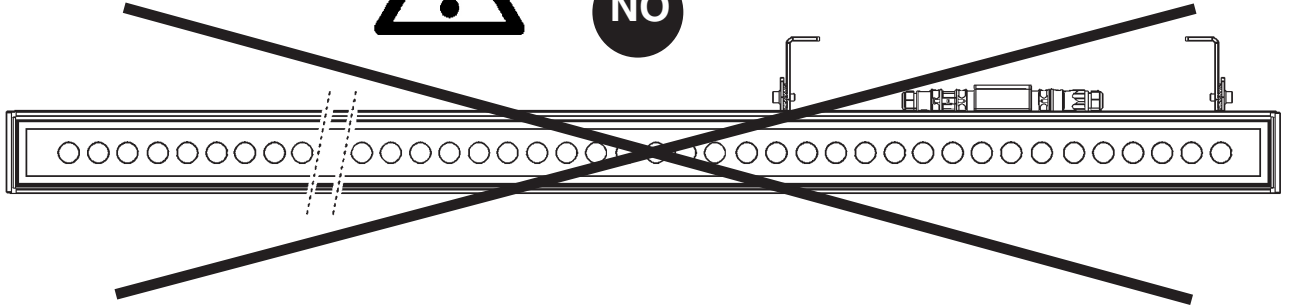

OK

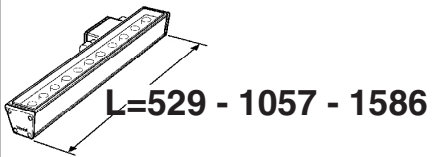
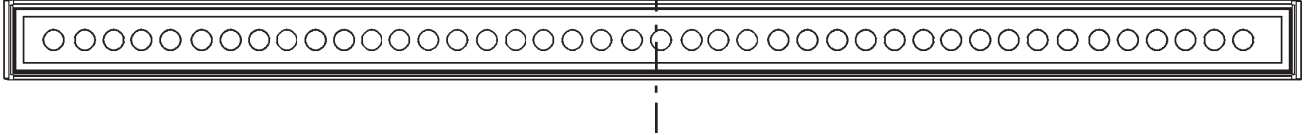
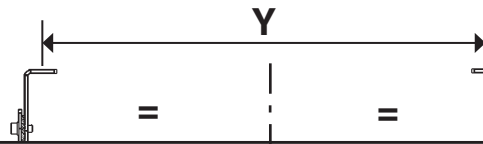

OK

K

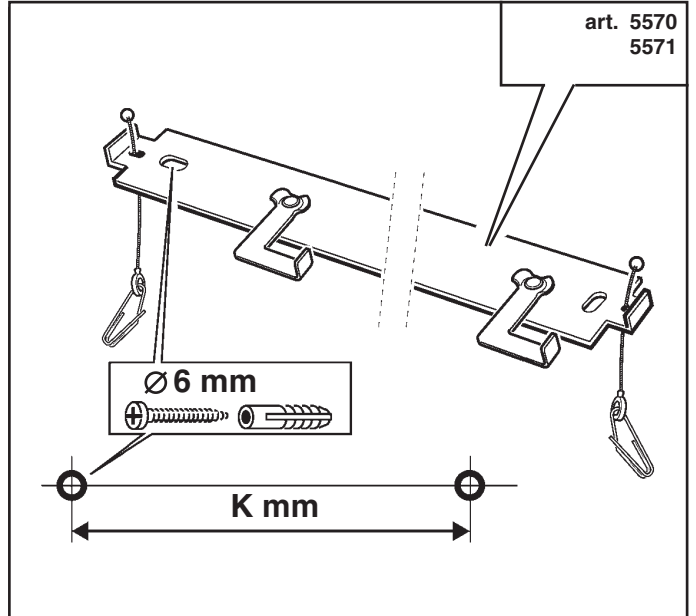
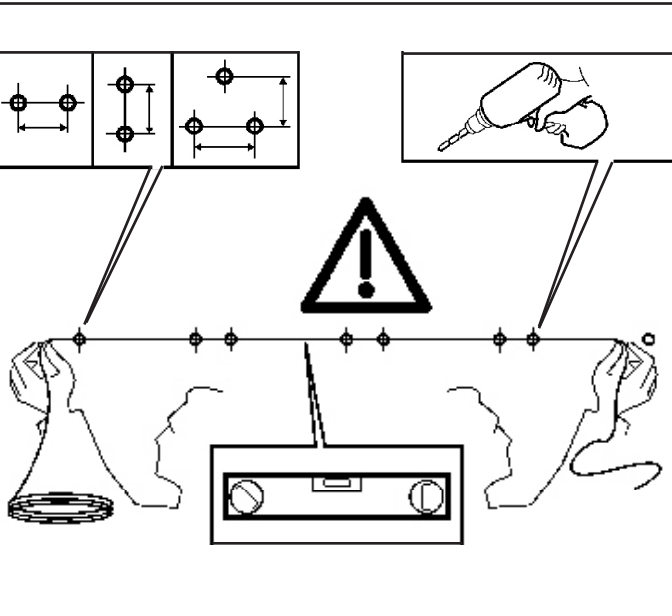
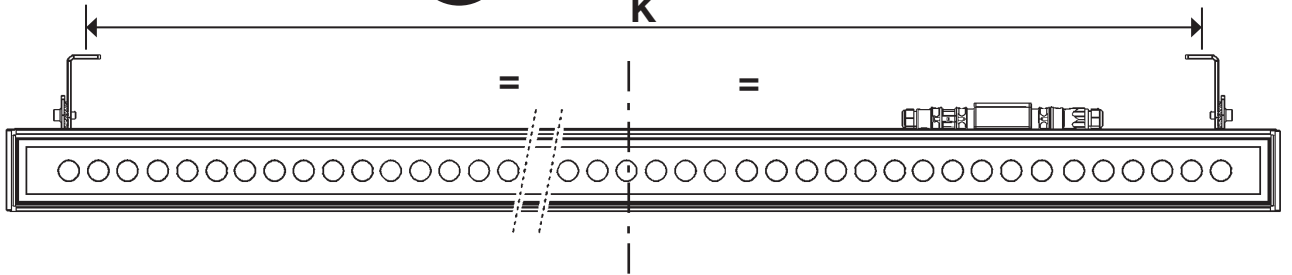

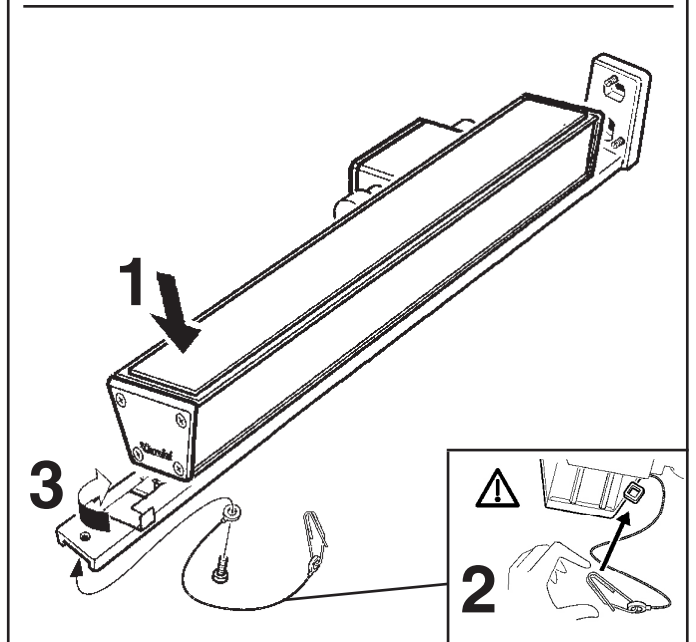
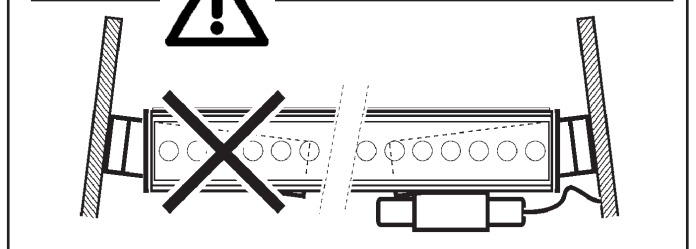
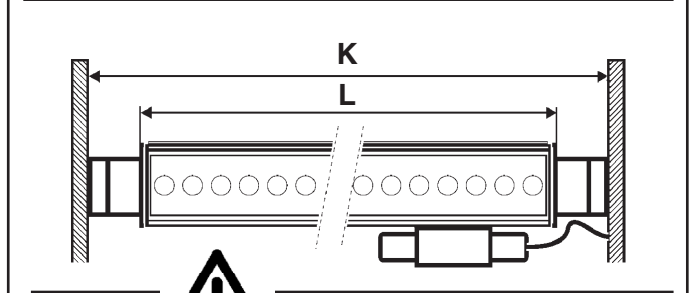
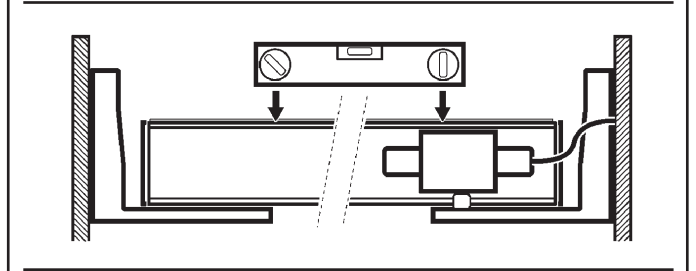
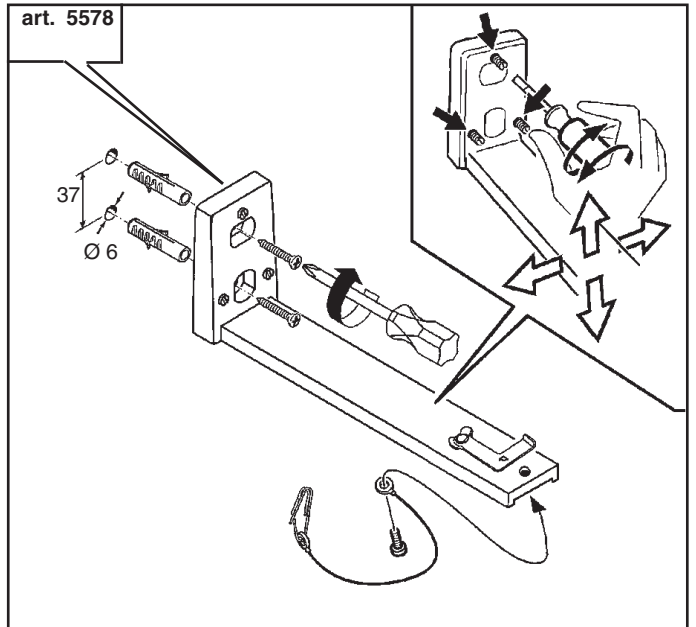
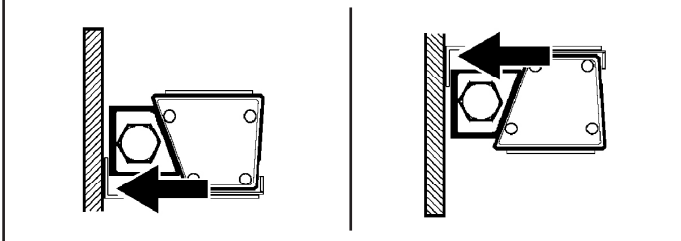
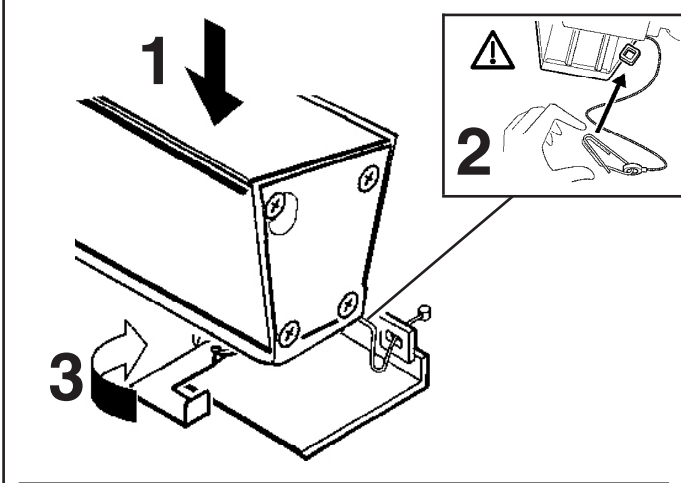
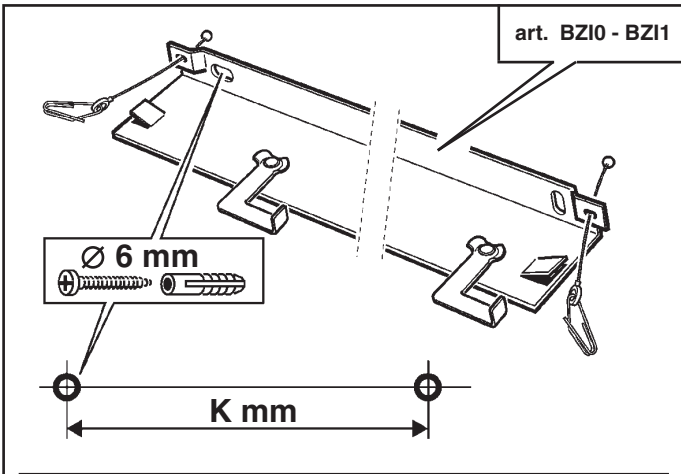
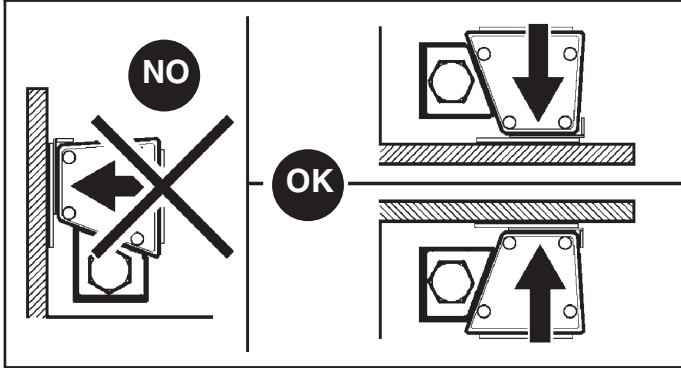
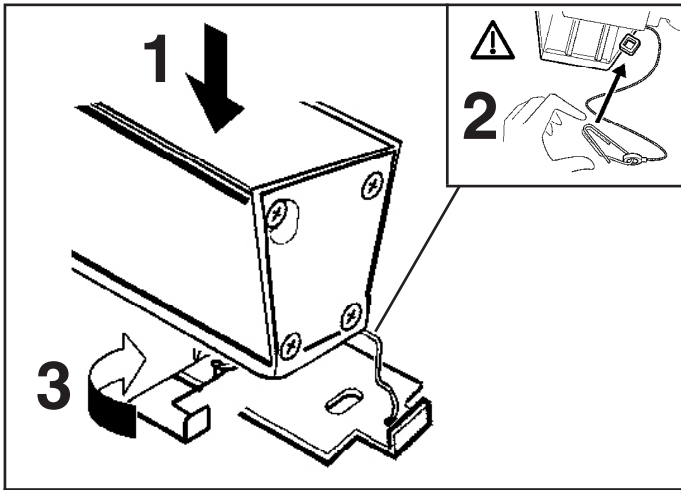

art. 5576

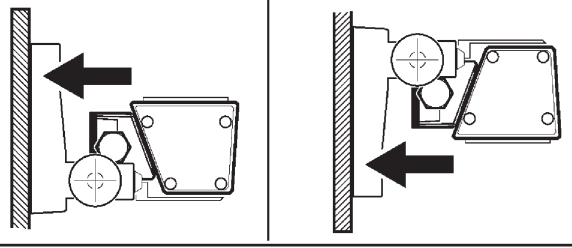
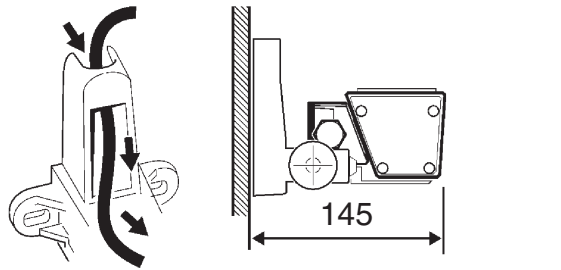
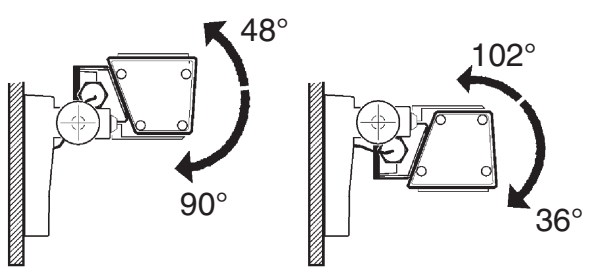
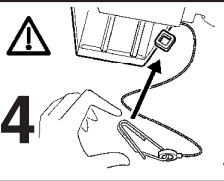
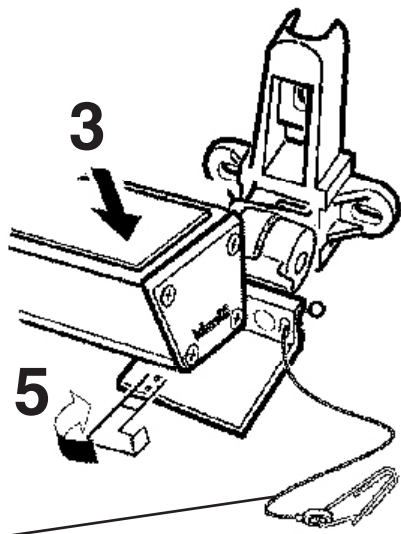
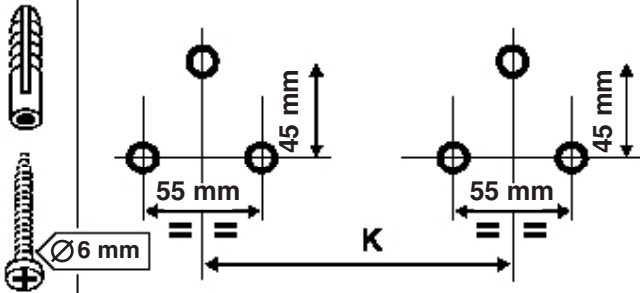
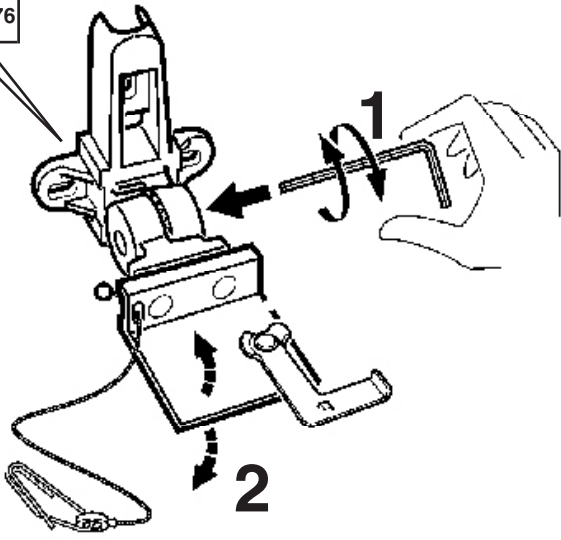

art. 5577

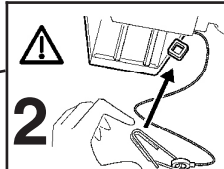
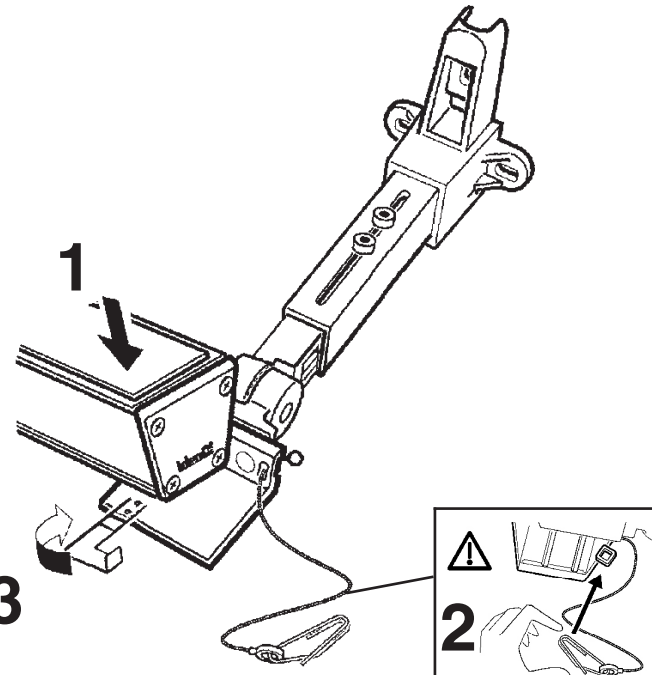
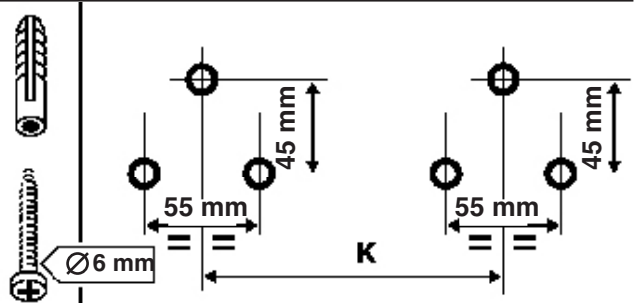
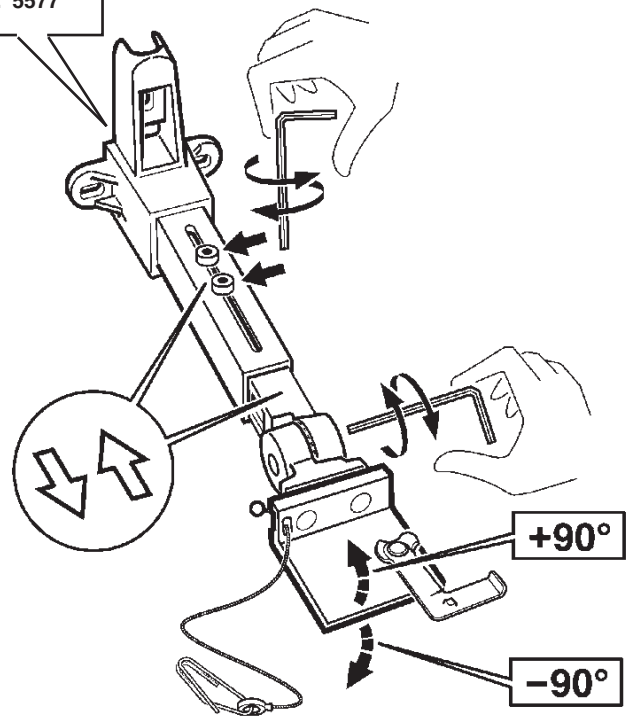

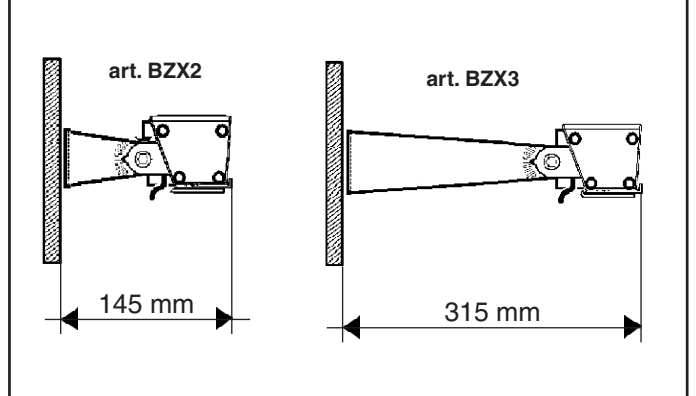
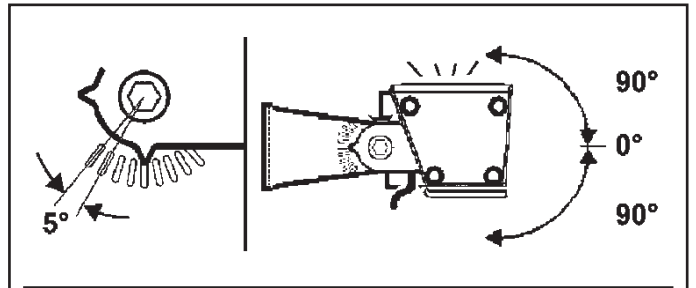
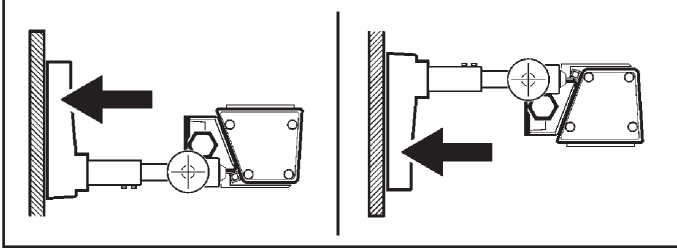
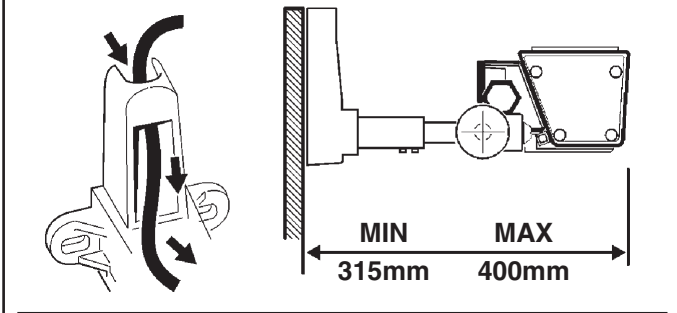
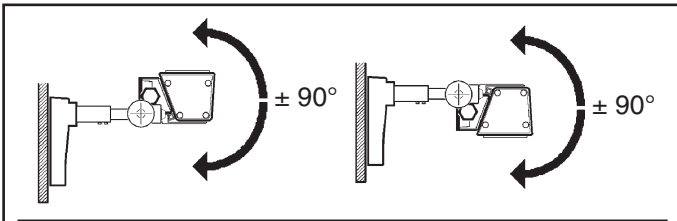

art. BZX2 - BZX3

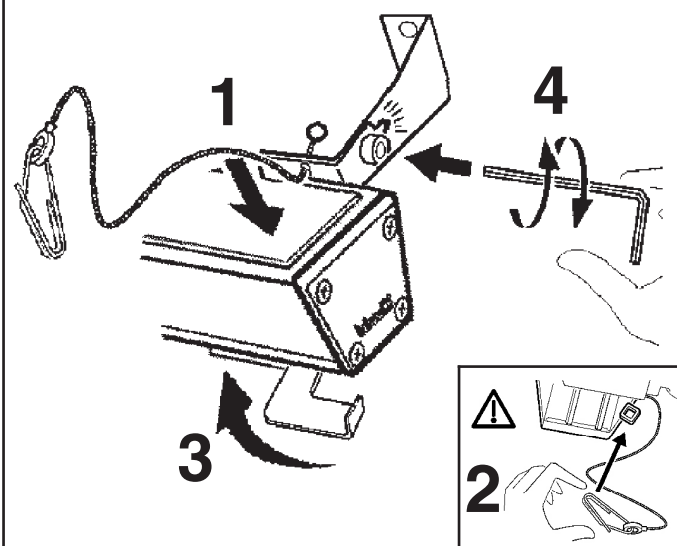
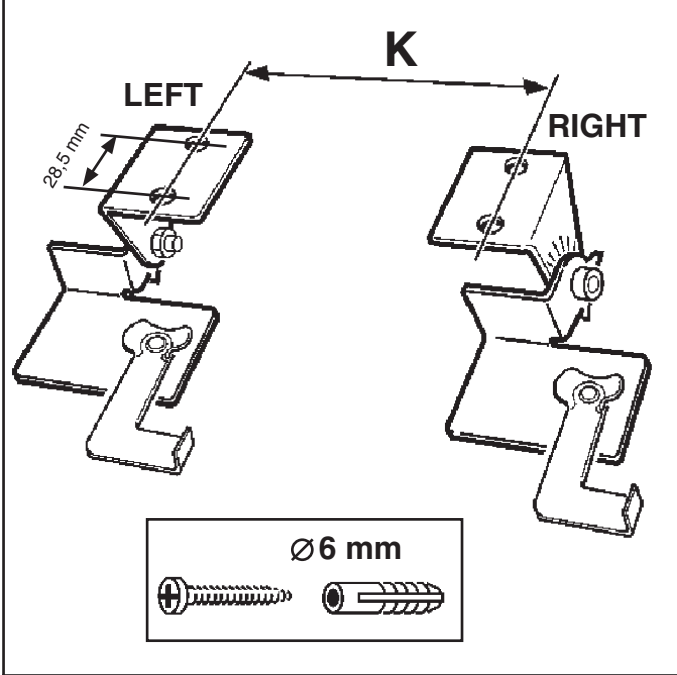

art. 5570 - 5571 - 5576 - 5577 - 5578 - BZIO
BZI1 - BZX2 - BZX3

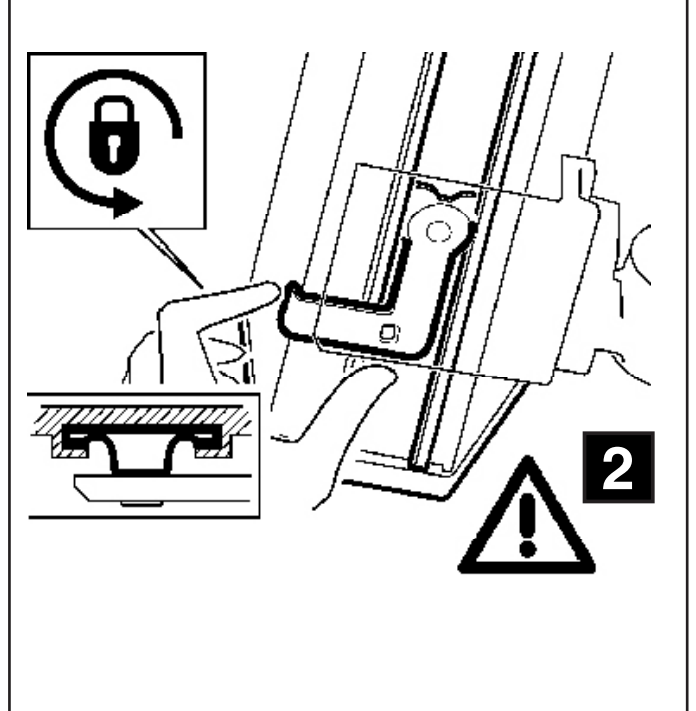
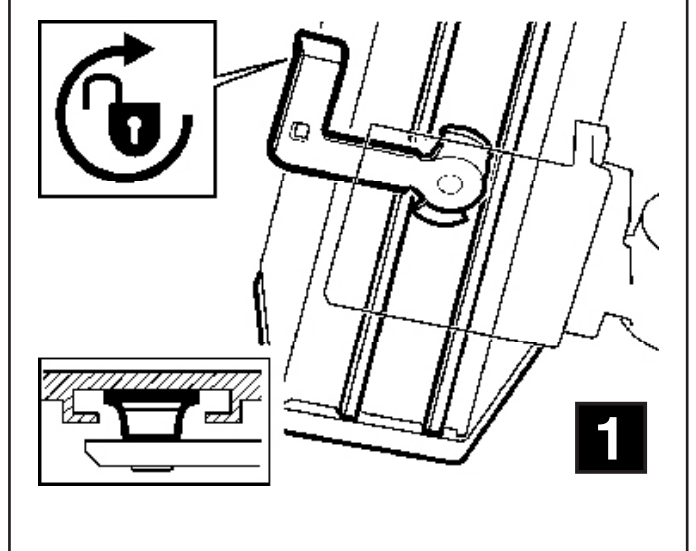

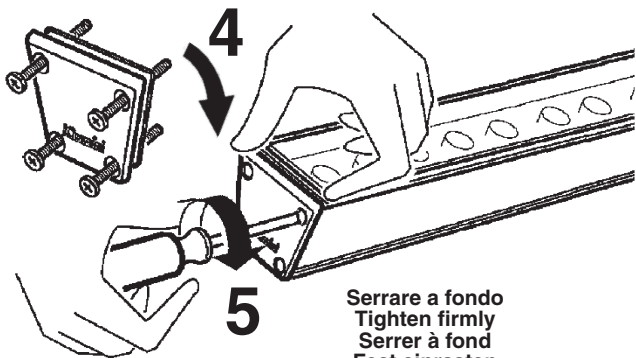
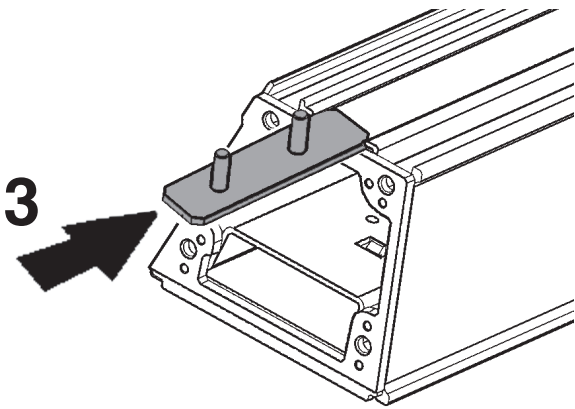
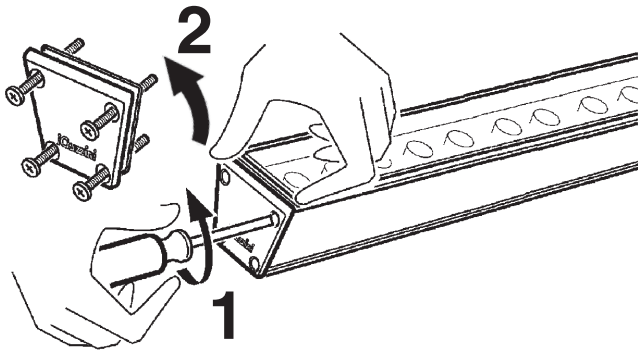
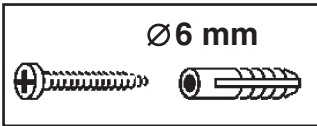
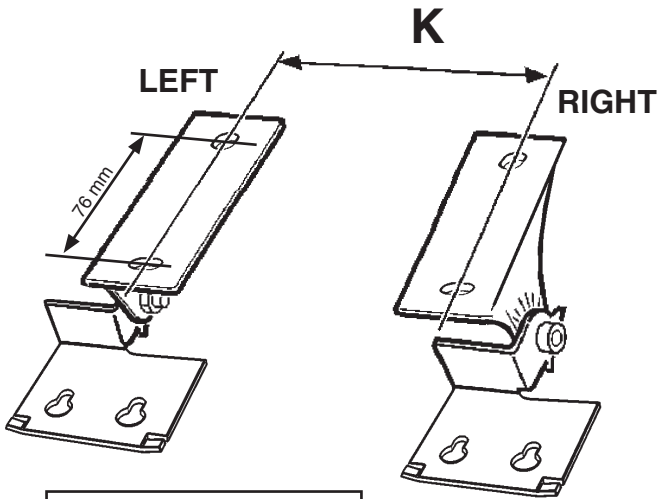

Serrare a fondo
Tighten firmly
Serrer à fond
Fest einrasten
Goed aanschroeven
Enrosca en firme
Skrues i bund
Trek til godt
Dra åt till botten
закручивать до упора
完全拧紧

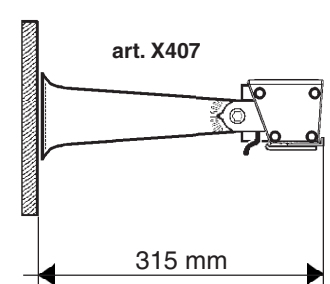
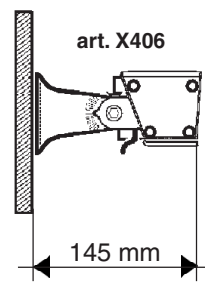
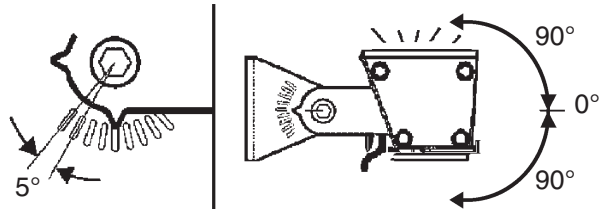
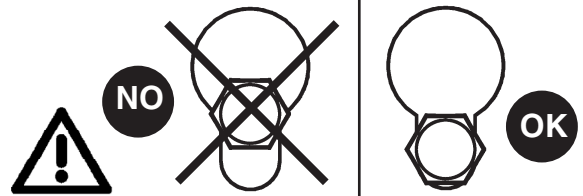
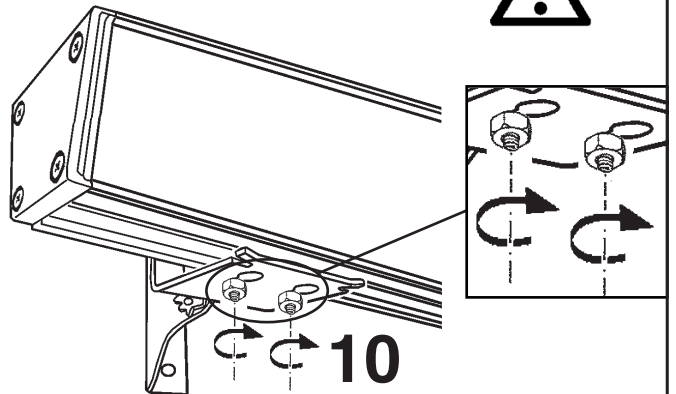
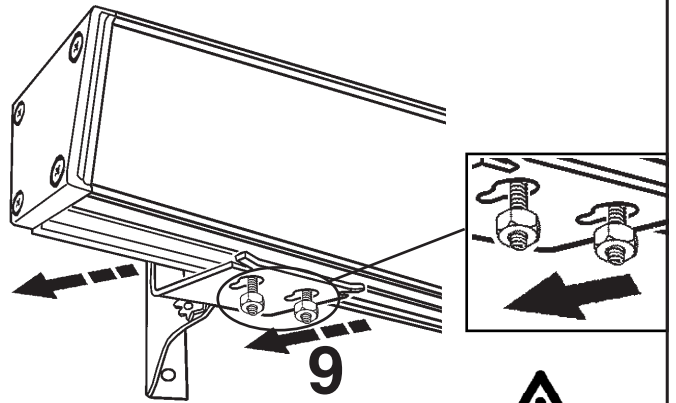
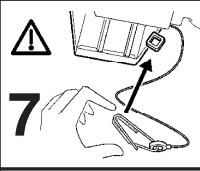
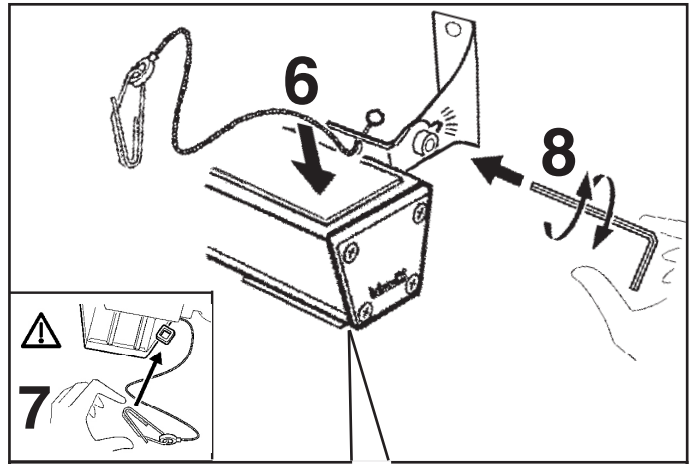

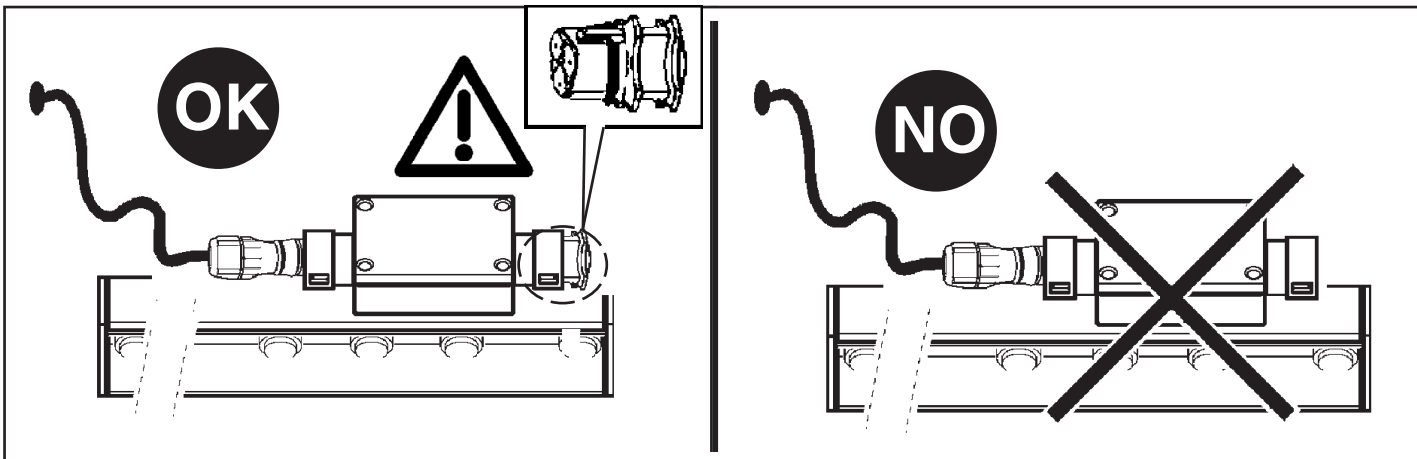
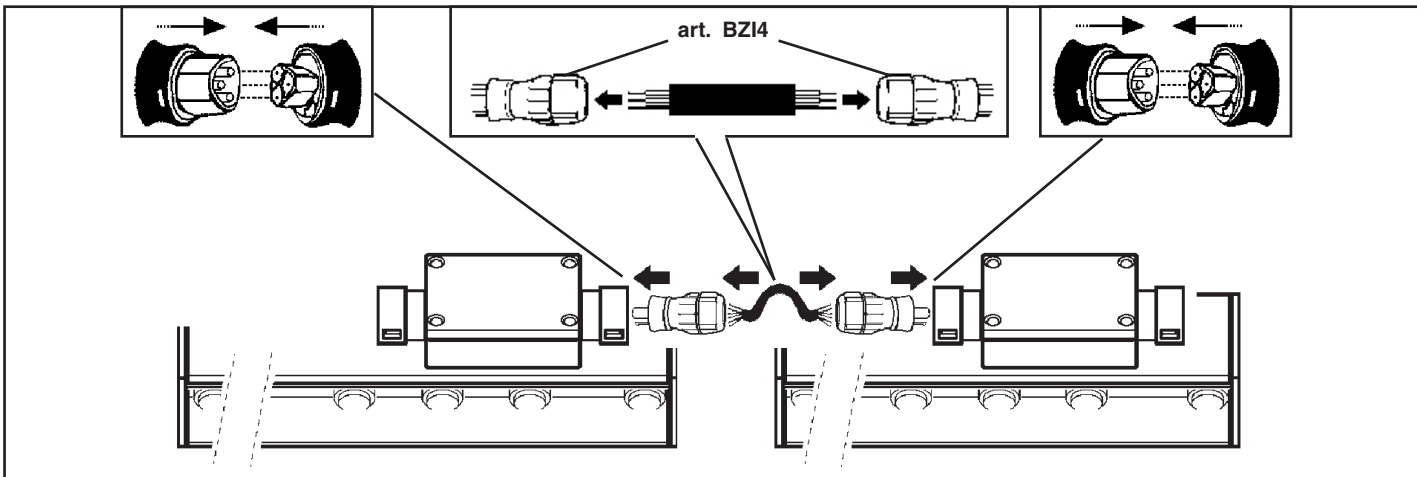
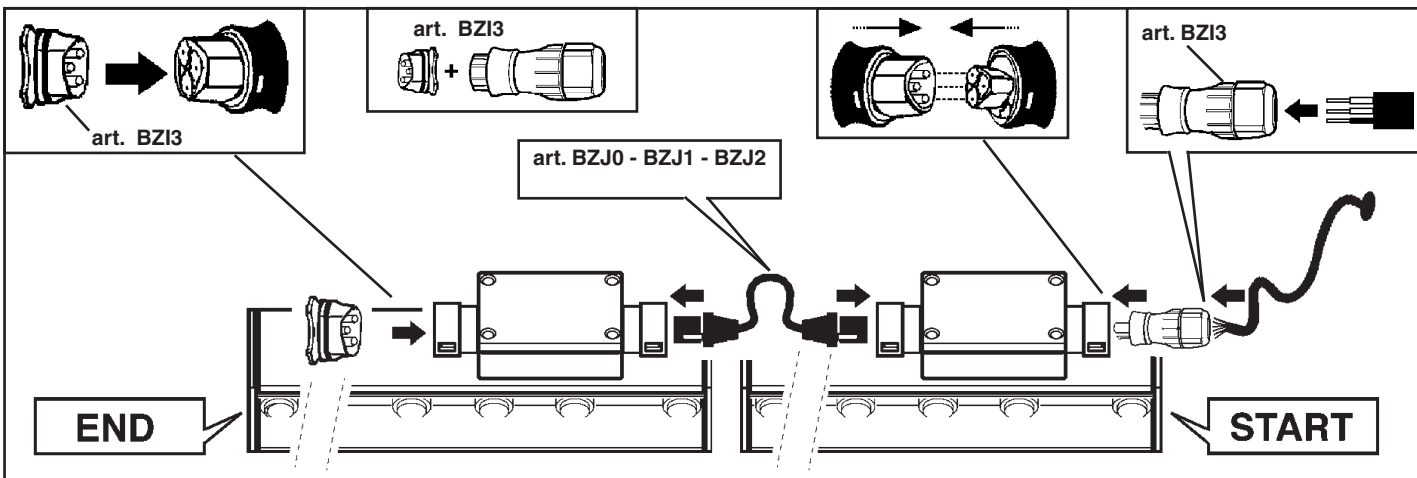
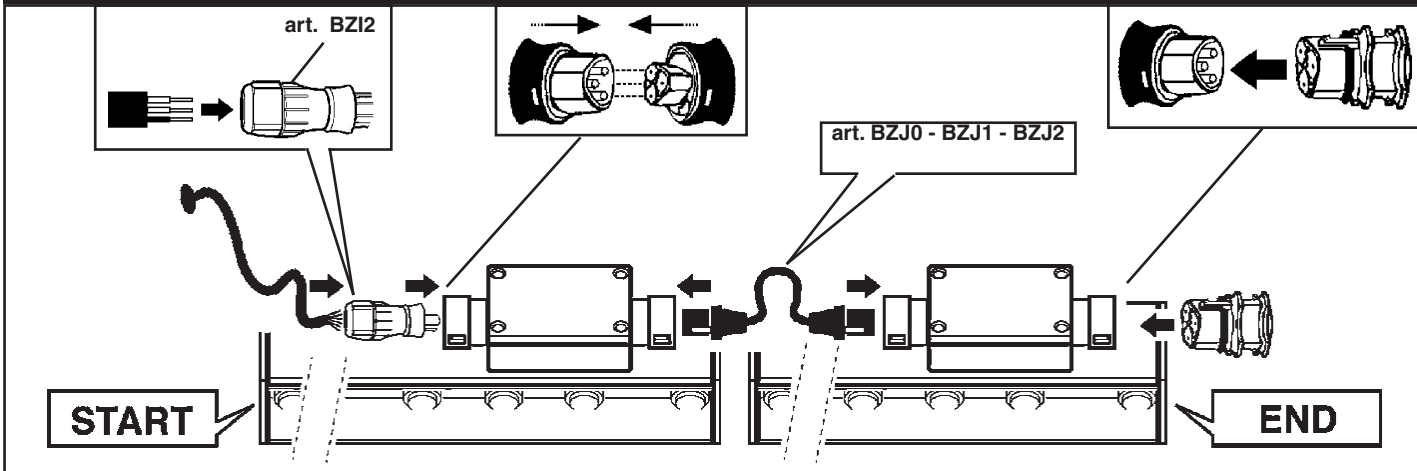
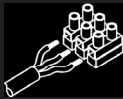

ART.	n° poli n° poles n° pôles n° Polen n° polen n° polos n° polerne n° polene n° polerna n° полюсов 芯数	cavo cable câble Kabel kabel cable ledning kabel kabel кабель 电缆 Ø(mm)	Sezione Section Section Querschnitt Doorsnede Sección Snit Avsnitt Tvärsnitt kabel Сечение 安裝区域 (mm ²)
BZI2	3	10 ÷ 14mm	2,5 ÷ 4 mm ² (max 6A / mm ²)
BZI3			
BZI4			

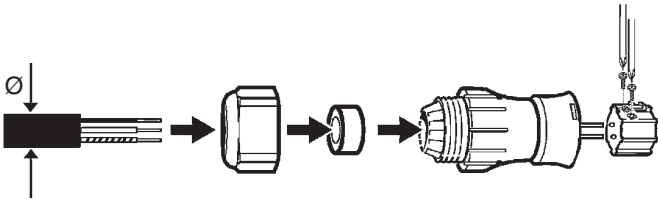
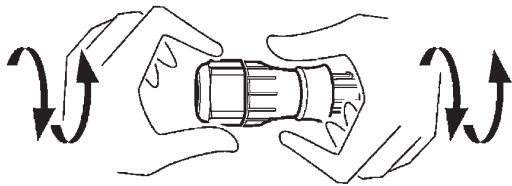
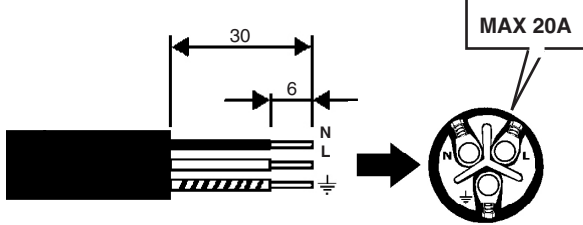

ART.	cavo cable câble Kabel kabel cable ledning kabel kabel кабель 电缆	X (mm)	L (mm)
BZJ0	3x2,5mm ² (max 15A)	430	525
BZJ1		960	1055
BZJ2		1490	1580

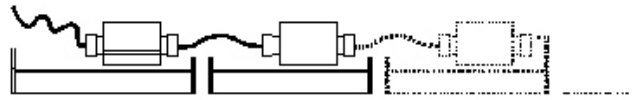
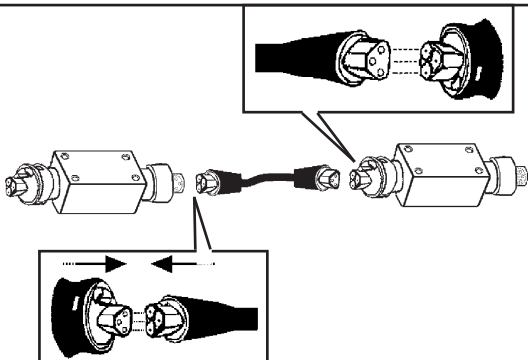
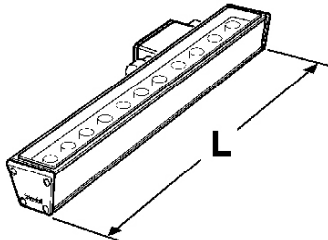

I Calcolare il numero massimo dei prodotti collegabili in cascata, tenendo conto dell'assorbimento dei prodotti, della sezione dei cavi, della lunghezza dei cavi e della corrente max dei connettori.

GB Calculate the maximum number of products connectable in cascade based on products' consumption, connectors' maximum current, cables' section and length.

F Calculer le nombre maximum de produits raccordable en cascade en tenant compte de la puissance absorbée par les luminaires, de la section et de la longueur des câbles ainsi que du courant maximum des connecteurs.

D Die maximale Anzahl der in Kaskadenschaltung anschließbaren Produkte unter Berücksichtigung der Leistungsaufnahme der Produkte, Kabeldurchmesser und -länge sowie des max. Stroms der Verbinder berechnen.

NL Bereken het maximale aantal producten dat in cascadevolgorde kan worden aangesloten. Houd rekening met de stroomopname van de producten, van de kabeldiameter, de lengte van de kabels en van de max stroom van de connectoren.

E Calcular el número máximo de productos conectables en cascada, teniendo en cuenta la absorción de los productos, la sección de los cables, la longitud de los cables y la corriente máxima de los conectores.

DK Beregn det maksimale antal produkter, der kan tilsluttes på række, idet der tages højde for produkternes strømforbrug, kablernes tværsnit og længde samt stikkens maksimale strømstyrke.

N Beregne maksimalt antall produkter som kan kaskadekobles. Ta med i betraktningen produktenes strømopptak, ledningenes tværsnitt og lengde, samt koblingsstykkenes toppstrøm.

S Beräkna max. antal produkter som kan kaskadkopplas genom att ta hänsyn till produkternas strömförbrukning, kablarnas tvärsnitt och längd, samt kontakternas max. ström.

RUS Рассчитать максимальное число последовательно подсоединяемых изделий, учитывая поглощение изделий, сечение и длину проводов и макс. ток разъемов.

CN 根据产品的能耗、连接端的最大电流、电线的截面大小和长度，计算出可并列连接的最多产品数。

I Maneggiare con cura e non sottoporre a tensioni meccaniche.

GB Handle with care and do not subject to mechanical stress.

F Manipuler avec précaution et ne pas soumettre à des contraintes mécaniques.

D Vorsichtig behandeln und keinen mechanischen Spannungen aussetzen.

NL Voorzichtig bij het gebruik van dit product. Mag niet worden onderworpen aan mechanische spanning.

E Manejar con cuidado y no someter a tensiones mecánicas.

DK Håndter med forsigtighed og udsæt ikke for mekaniske spændinger.

N Må behandles forsiktig. Må ikke utsettes for mekaniske spenninger.

S Ska hanteras försiktigt och inte utsättas för mekaniska påfrestningar.

RUS Обращаться осторожно и не подвергать механическому напряжению

CN 小心轻放，切勿使其遭受机械应力

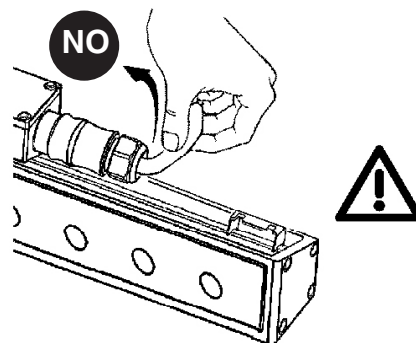
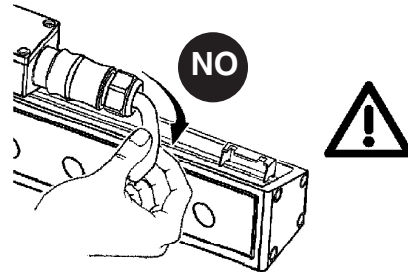
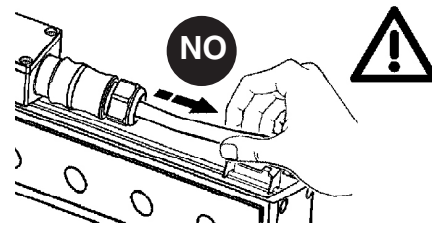

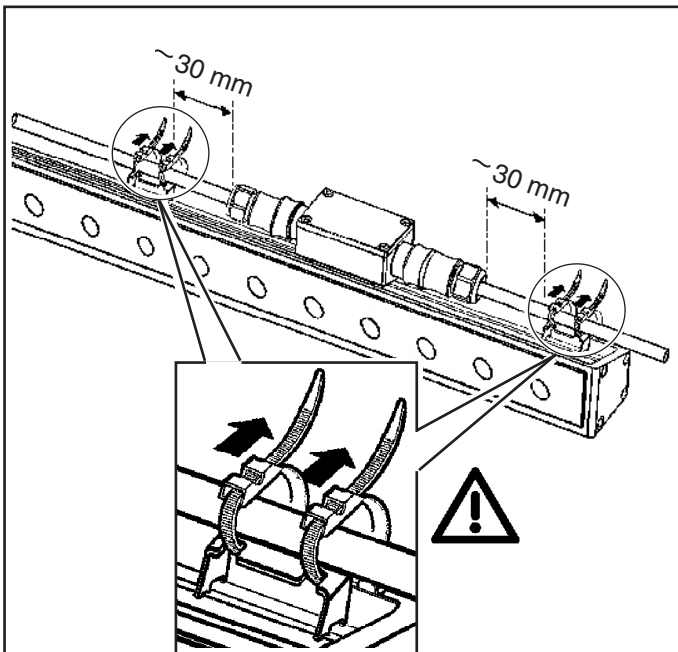

art. BZIO - BZ11 - 5570
5571 - 5576 - 5577
5578 - BXZ2
BXZ3

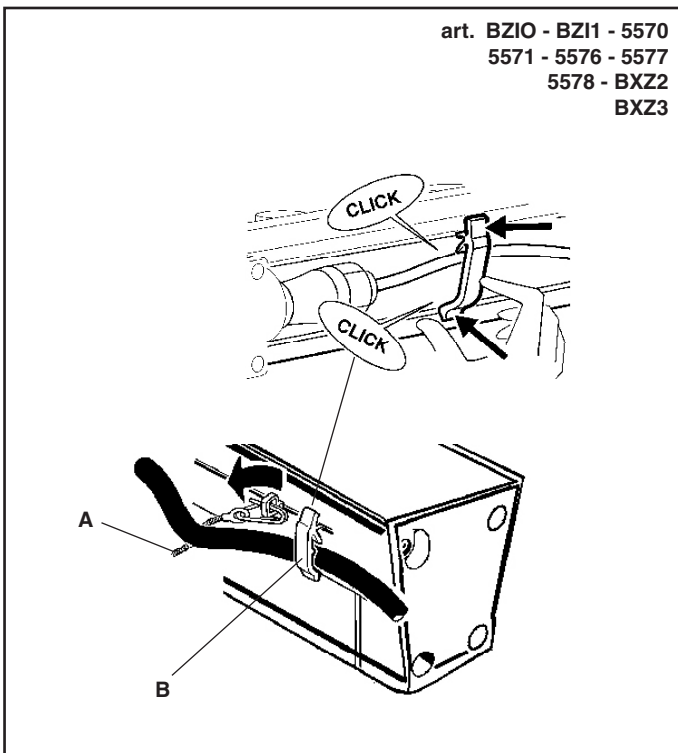

I Prima di bloccare il modulo al supporto meccanico, agganciare i cavetti d'acciaio "A" come indicato in figura. Utilizzare le clips "B" per sistemare i cavi elettrici perfettamente dietro al modulo.

GB Before locking the module onto the mechanical support, hook on the steel cables "A" as indicated in the figure. Use the clips "B" to tidy up the electric cables behind the module.

F Avant de bloquer le module à son support mécanique, accrochez les fils en acier «A» comme illustré. Utilisez les clips «B» pour bien ranger les câbles électriques derrière le module.

D Bevor Sie das Modul an der Haltevorrichtung festmachen, haken Sie die Stahldrähte „A“ ein (siehe Abbildung). Benützen Sie die Clips „B“, um die Stromkabel ordentlich hinter dem Modul festzumachen.

NL Voordat het armatuur aan de mechanische steun wordt bevestigd moeten de staaldraden "A" worden aangehaakt zoals aangegeven in de afbeelding.

E Antes de fijar el módulo al soporte mecánico, enganchar los cables de acero «A» según ilustrado en la figura. Utilizar las clips «B» para el perfecto alojamiento de los cables en el módulo.

DK Inden modulet fastgøres til det mekaniske beslag, skal stålklablerne "A" hægtes på, som vist i figuren. Brug klemmerne "B" til at samle de elektriske ledninger bag modulet.

N Før modulet låses på den mekaniske støtten, festes stålklablerna "A" slik som vist på figuren. Bruk klemmene "B" til å ordne de elektriske kablene bak modulet.

S Haka fast ståltrådarna A enligt figuren innan modulet sätts fast i den mekaniska hållaren. Använd klämmorna B för att placera elkablarna korrekt bakom modulet.

RUS Перед закреплением модуля на механической опоре подсоедините стальные тросы «А», как показано на схеме. Используйте зажимы «В» для крепления электрических проводов в точности позади модуля.

CN 在将模块锁到机械支架上前，如图所示将其钩在钢缆“A”上。用夹子“B”整理模块后的电缆。



N.B.: DURANTE L'INSTALLAZIONE DEL SISTEMA RISPETTARE SCRUPolosAMENTE LE NORME IMPIANTISTICHE VIGENTI.

N.B.: WHEN INSTALLING THE SYSTEM, STRICTLY COMPLY WITH ALL REGULATIONS ON INSTALLATION IN FORCE.

N.B.: LORS DE L'INSTALLATION DU SYSTÈME VEUILLEZ RESPECTER RIGOREUSEMENT LES NORMES EN VIGUEUR EN LA MATIÈRE.

NB: BEACHTEN SIE BEI DER INSTALLATION DES SYSTEMS GEWISSENHAFT DIE GÜLTIGEN BESTIMMUNGEN BEZÜGLICH DER ANLAGENTECHNIK.

N.B.: BIJ HET INSTALLEREN VAN HET SYSTEEM MOET U DE GELDEN DE INSTALLATIE-NORMEN STRIKT NALEVEN.

N.B.: DURANTE LA INSTALACIÓN DEL SISTEMA RESPETAR E SCRUPulosAMENTE LAS NORMAS DE INSTALACIÓN VIGENTES.

N.B.: UNDER INSTALLATION AF SYSTEMET SKAL MAN NØJE OVERHOLDE DE GÆLDENDE REGLER FOR DISSE ANLÆG.

N.B.: VED INSTALLASJON AV SYSTEMET SKAL ALLE FORSKRIFTER OM INSTALLASJON SOM GJELDER FØLGES STRENGT.

OBS! UNDER INSTALLATIONEN AV SYSTEMET SKA INSTALLATIONSFÖRESKRIFTERNA RESPEKTERAS I DETALJ.

ПРИМЕЧАНИЕ: В ПРОЦЕССЕ МОНТАЖА СИСТЕМЫ СТРОГО СОБЛЮДАЙТЕ НАЦИОНАЛЬНЫЕ ДЕЙСТВУЮЩИЕ НОРМАТИВЫ ПО ЭЛЕКТРОПРОВОДКЕ.

注意：在安装系统时请遵守设备的安装规定。

I N.B.: Per la sostituzione del LED contattare l'azienda iGuzzini.

GB N.B.: For information on LED replacement please contact iGuzzini.

F N.B.: Pour procéder au remplacement de la LED, adressez-vous à la société iGuzzini.

D Ñ.B.: Bezüglich des Austausches der LED kontaktieren Sie bitte die Firma iGuzzini.

NL N.B.: Voor het vervangen van de LED neemt u contact op met het bedrijf iGuzzini.

E NOTA: Para sustituir el LED llame a la empresa iGuzzini.

DK N.B.: For udskiftning af lysdioden, skal man kontakte iGuzzini.

N N.B.: For informasjon om skifte av LED, vennligst ta kontakt med iGuzzini.

S OBS! För byte av lysdioden, kontakta företaget iGuzzini.

RUS ПРИМЕЧАНИЕ: Для замены СИДов обращайтесь в компанию iGuzzini.

CN 注意：如需LED更换的信息，请联系iGuzzini。



I In caso di rottura delle lenti il prodotto non può essere utilizzato, contattare il costruttore per la sua sostituzione.

GB Should the lenses break, the product cannot be used. Contact the manufacturer for replacement.

F En cas de rupture des lentilles, le produit ne peut plus être utilisé. Contacter le fabricant pour procéder à son remplacement.

D Im Falle einer Beschädigung der Linsen darf das Produkt nicht verwendet werden. Setzen Sie sich bitte mit dem Hersteller in Verbindung, der für den Ersatz sorgen wird.

NL Indien de lenzen kapot zijn kan het product niet geïnstalleerd worden. Neem contact op met de fabrikant om ze te vervangen.

E En caso de rotura de las lentes, el producto no puede utilizarse y se debe contactar con el fabricante para su sustitución.

DK Hvis produktets linser ødelægges, kan det ikke anvendes. Kontakt producenten med henblik på udskiftning.

N Hvis linsene blir ødelagt kan ikke produktet brukes lenger. Ta kontakt med produsenten for å få det skiftet ut.

S Produktet kan inte användas vid brott på linser. Kontakta tillverkaren för byte av linser.

RUS В случае повреждения линз прибор нельзя использовать, обратиться к производителю для его замены.

CN 如果镜头破裂，请不要使用该产品。请联系制造商进行更换。



art. BZH7 - BZH8 - BZH9

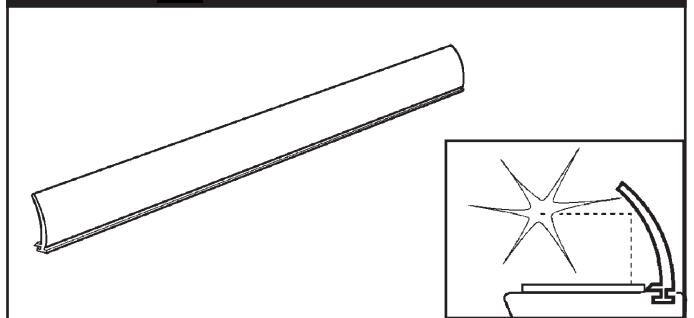

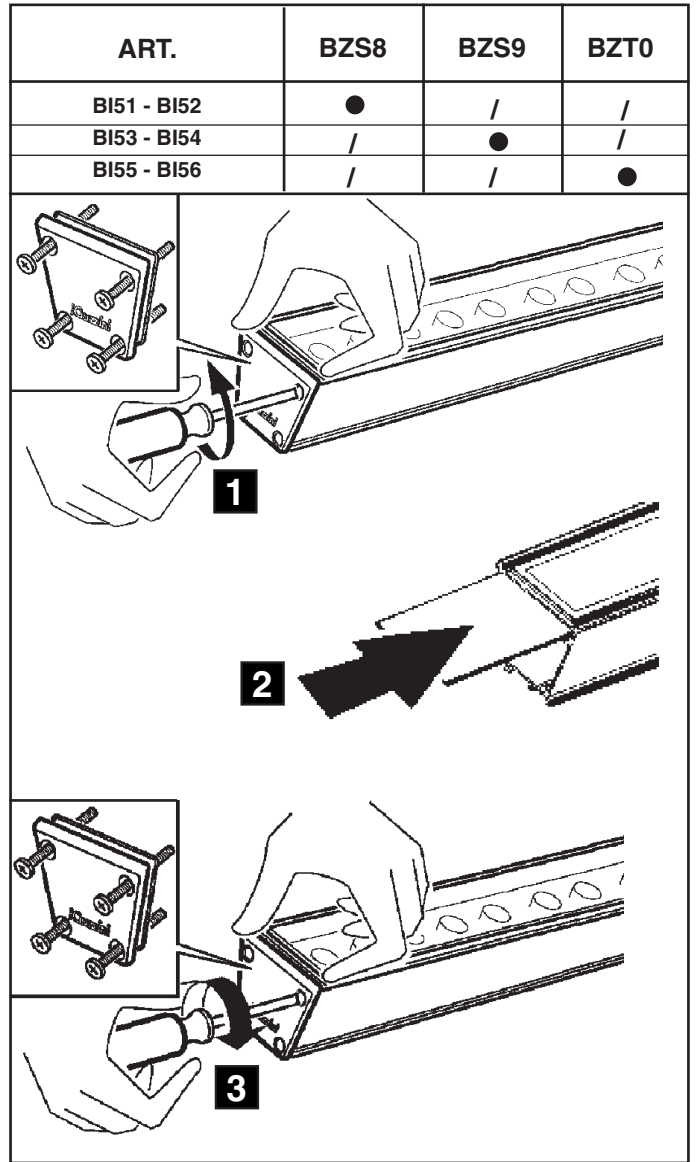
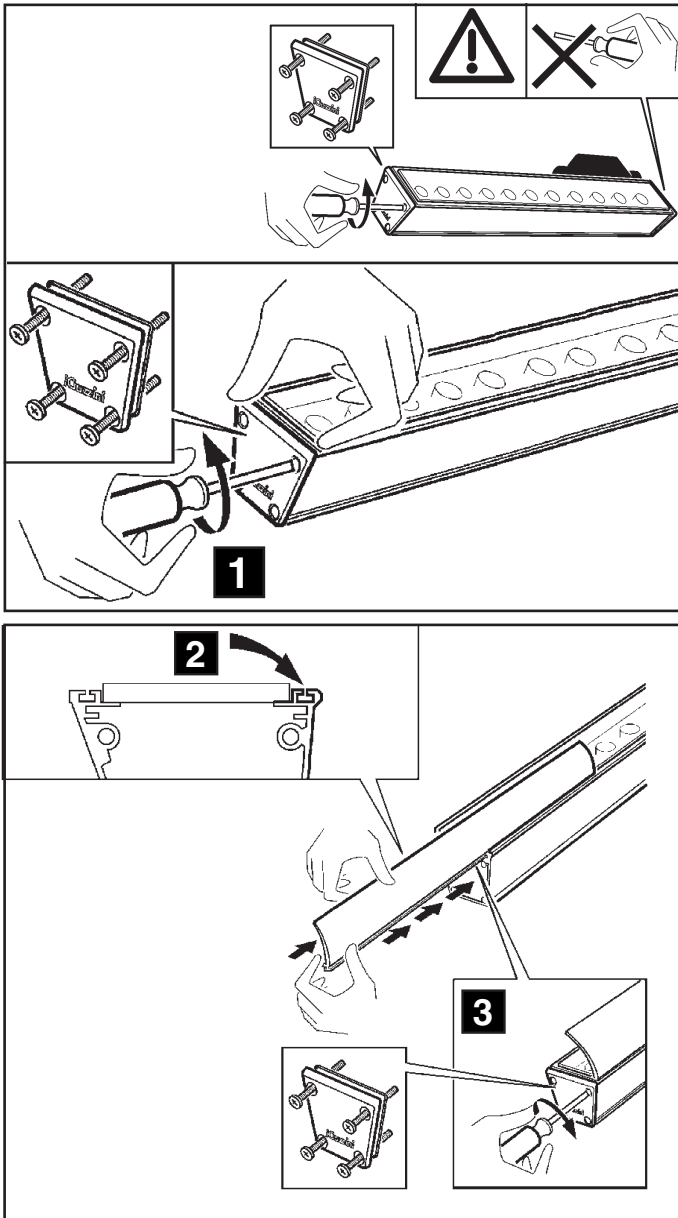

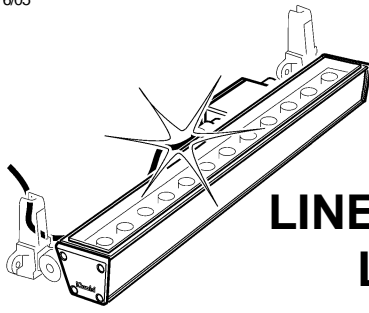

LINEALUCE LED

WARNING:

THE SAFETY OF THIS FIXTURE IS GUARANTEED ONLY IF YOU COMPLY WITH THESE INSTRUCTIONS; REMEMBER TO CONSERVE IN A SAFE PLACE.

ATTENTION:

LA SECURITE DE L'APPAREIL N'EST GARANTIE QU'EN CAS D'UTILISATION CORRECTE DES INSTRUCTIONS SUIVANTES; IL FAUT PAR CONSEQUENT LES CONSERVER.

ATENCION:

LA SEGURIDAD DEL APARATO SE GARANTIZA SOLO CUMPLIENDO CUIDADOSAMENTE LAS SIGUIENTES INSTRUCCIONES; POR ELLO, ES NECESARIO CONSERVARLAS.

ATTENZIONE:

LA SICUREZZA DELL'APPARECCHIO E' GARANTITA SOLO CON L'USO APPROPRIATO DELLE SEGUENTI ISTRUZIONI; PERTANTO E' NECESSARIO CONSERVARLE.

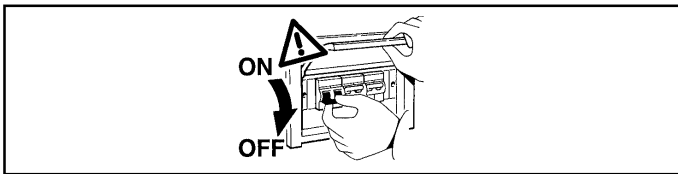

GB Install in accordance with National electric code, local and federal code specifications.

F Veuillez installer ce produit en conformité avec le code électrique national et les spécifications du code local et fédéral.

E Instalar el producto respetando las normas eléctricas nacionales y las especificaciones de las normas locales y federales.

I Installare il prodotto rispettando il codice elettrico nazionale, le specifiche del codice locale e federale.

	ART.	L
	BG96 - BG97 - BH02 - BH03 BH08 - BH09 - BI51 - BI52	529 mm 20 13/16 in
	BG98 - BG99 - BH04 - BH05 BH10 - BH11 - BI53 - BI54	1057 mm 41 5/8 in
	BH00 - BH01 - BH06 - BH07 BH12 - BH13 - BI55 - BI56	1586 mm 62 7/16 in

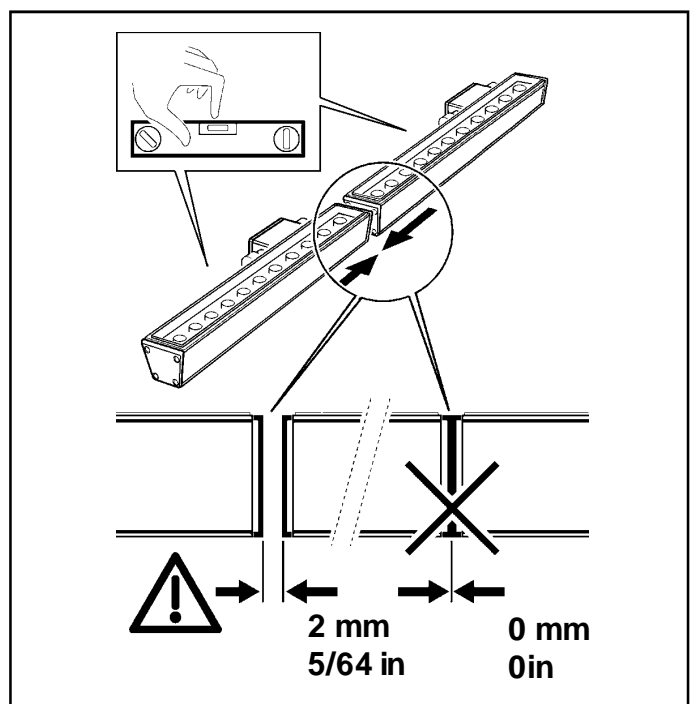
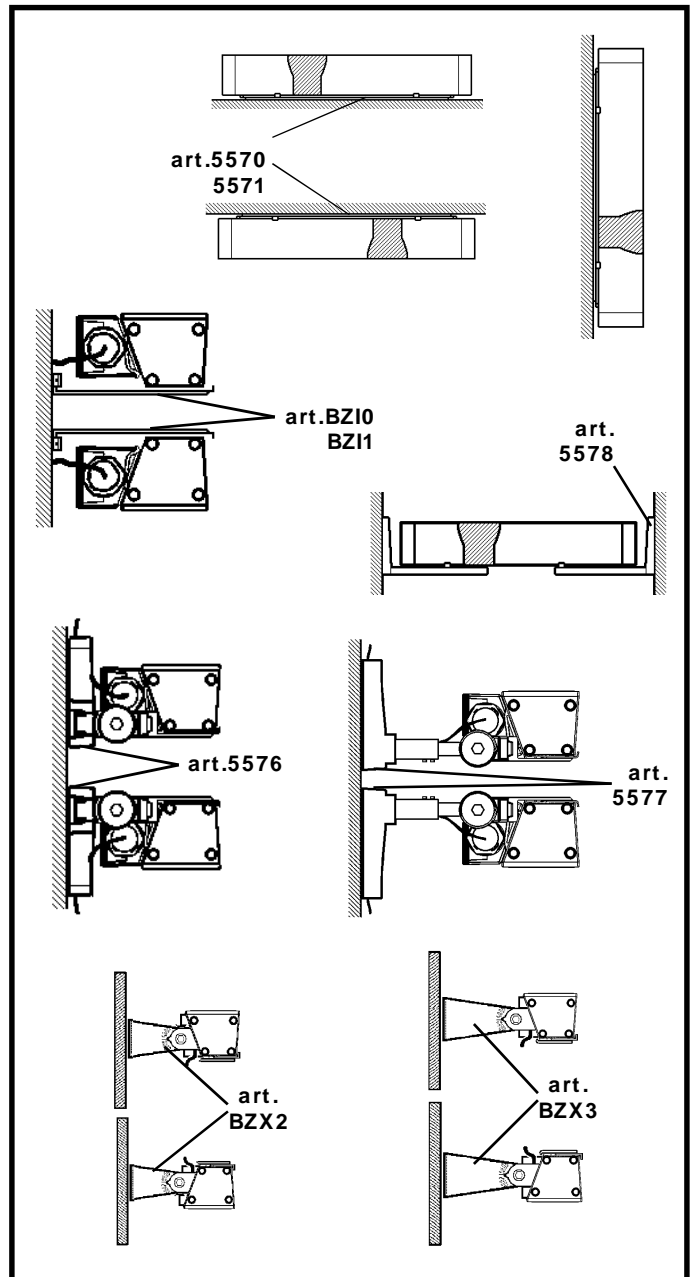
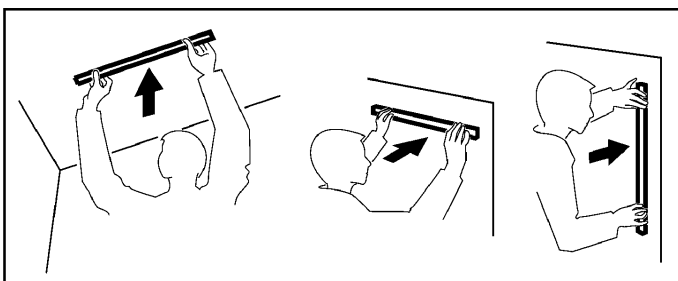
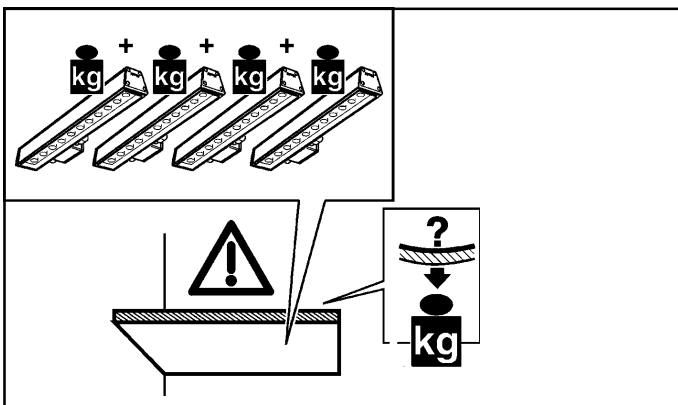

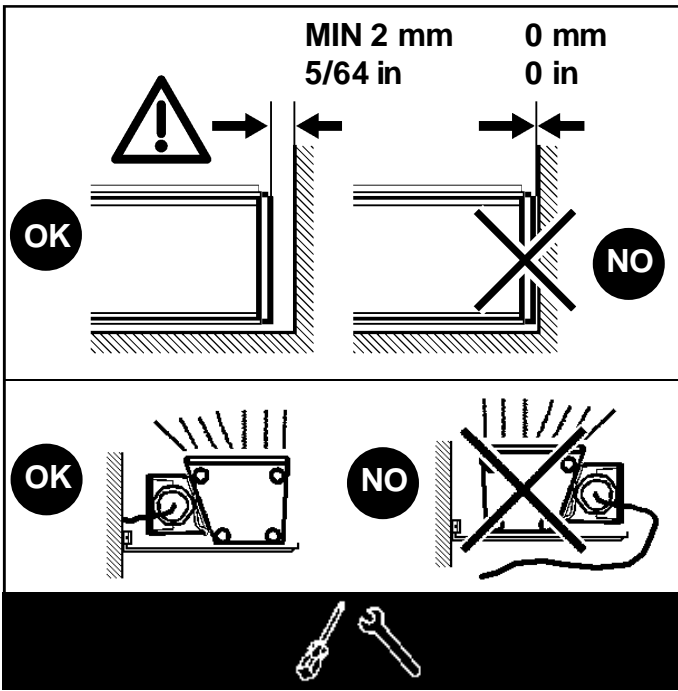

INSTALLAZIONE DEI SUPPORTI MECCANICI
 INSTALLATION OF THE MECHANICAL SUPPORTS
 INSTALLATION DES SUPPORTS MECANIQUES
 INSTALACIÓN DE LOS SOPORTES MECÁNICOS

TABLE OF CENTRE TO CENTRE - DISTANCES OF HOLING - TABLEAU DES ESPACEMENT
 DE PERCAGE - TABLA INTER-EJES DE PERFORACION - TABELLA INTERASSI DI FORATURA

ART.	BZ10	BZ11	5570	5576	5578
	K	K	5571 K	5577 K	5578 K
BG96 - BG97 - BH02 BH03 - BH08 - BH09 BI51 - BI52	240mm 9 7/16 in	-	265mm 10 7/16 in	220mm 8 11/16 in	600mm 23 5/8 in ÷ 900mm 35 7/16 in
BG98 - BG99 - BH04 BH05 - BH10 - BH11 BI53 - BI54	240mm 9 7/16 in	600mm 23 5/8 in	265mm 10 7/16 in	400mm 15 3/4 in	1094mm 43 1/16 in ÷ 1474mm 58 1/16 in
BH00 - BH01 - BH06 BH07 - BH12 - BH13 BI55 - BI56	240mm 9 7/16 in	600mm 23 5/8 in	600mm 23 5/8 in	400mm 15 3/4 in	1622mm 63 7/8 in ÷ 2002mm 78 13/16 in

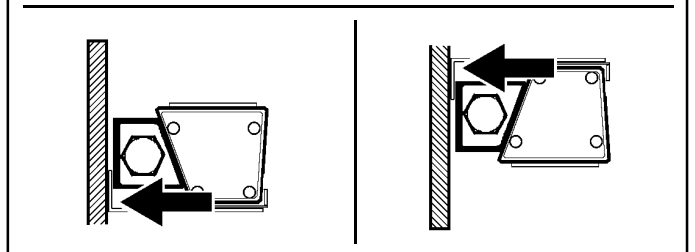
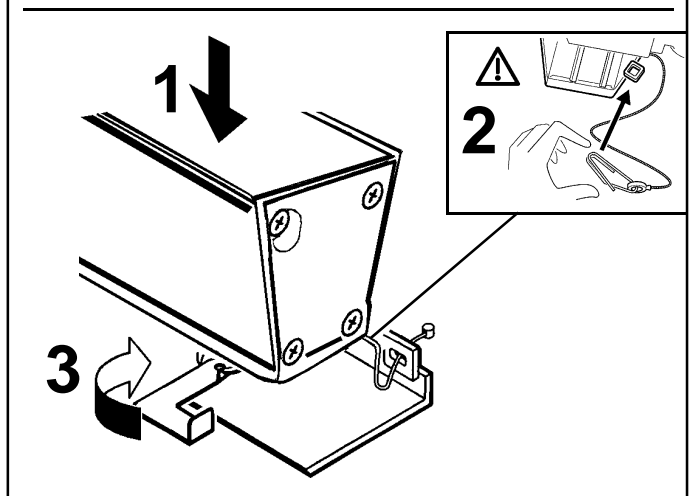
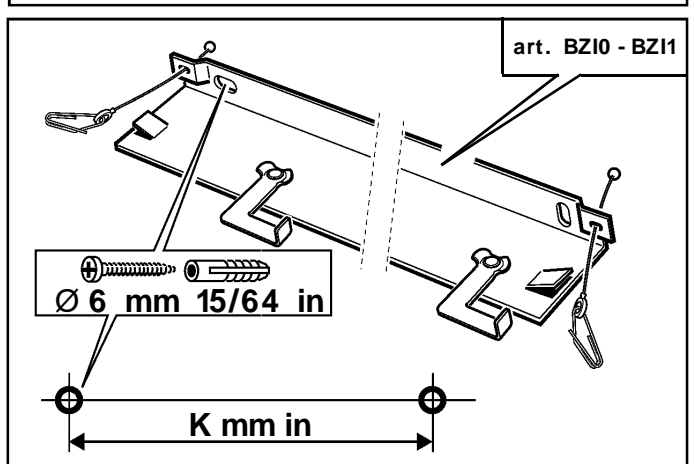
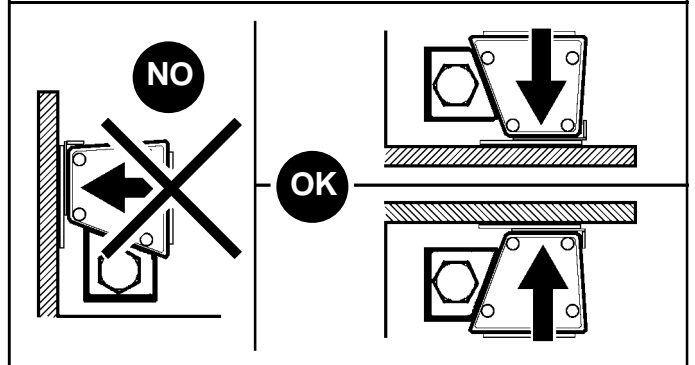
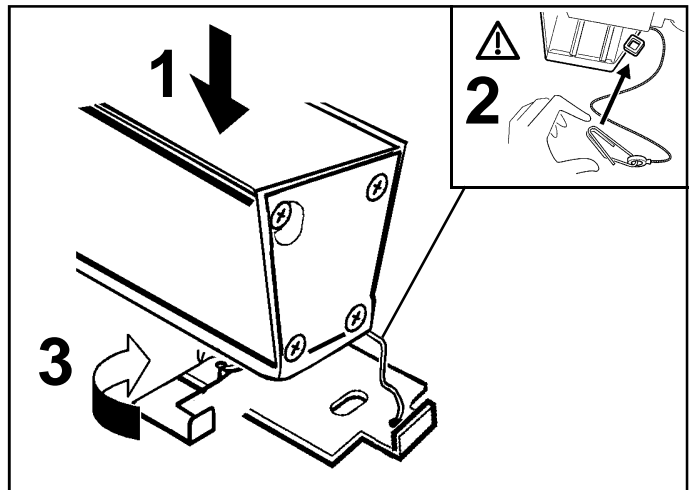
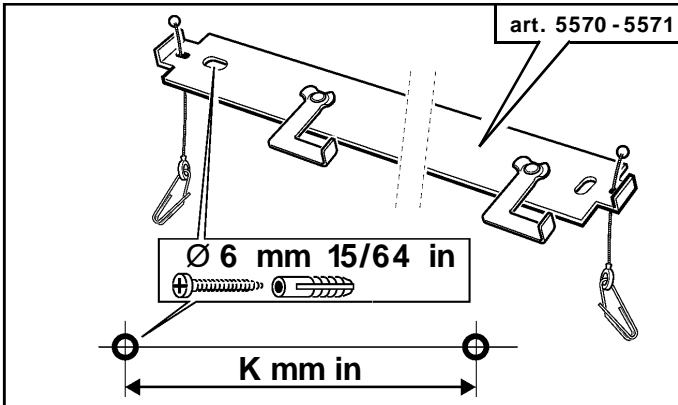
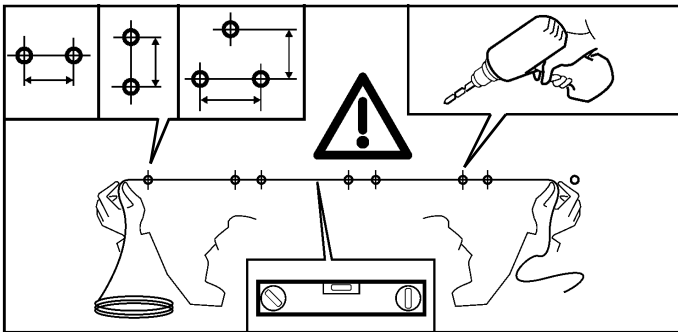

art. 5578

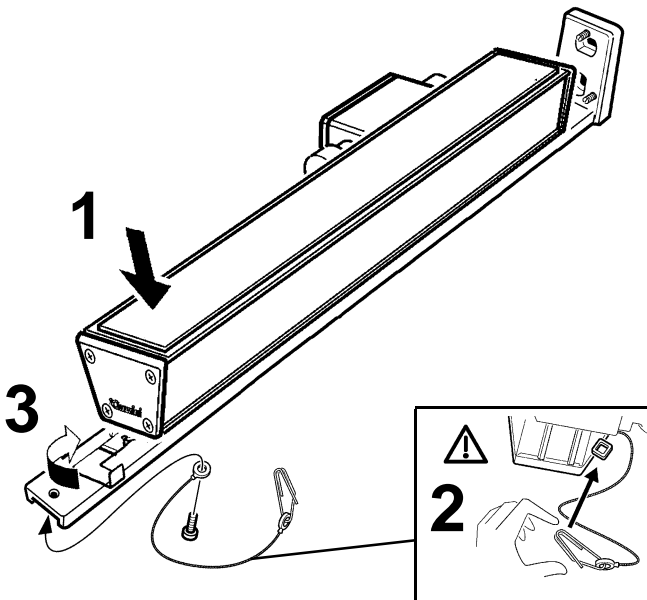
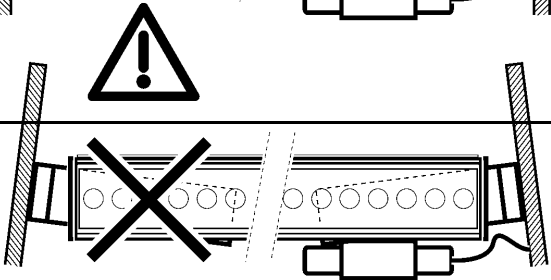
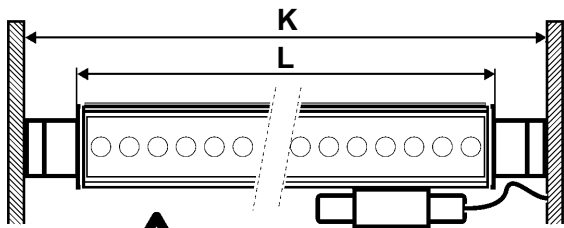
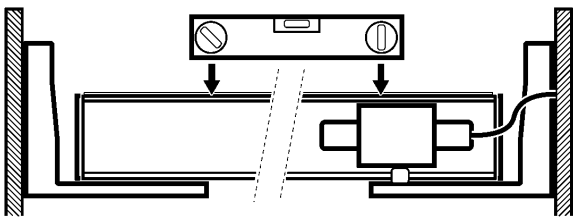
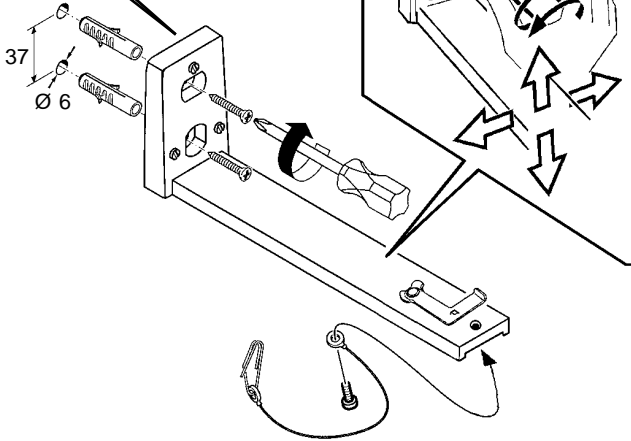

art. 5576

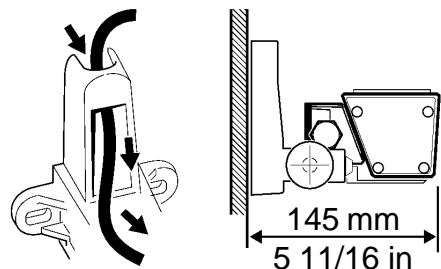
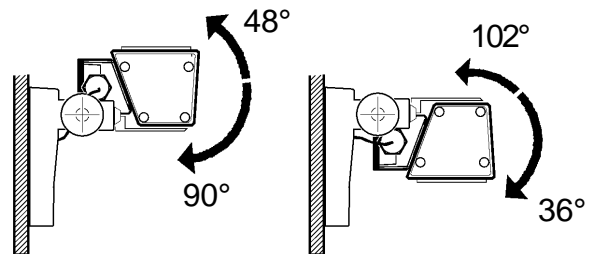
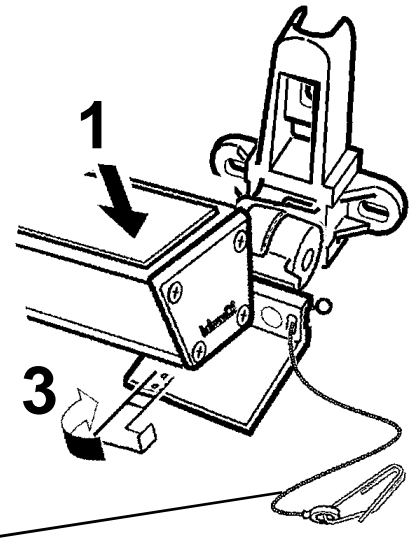
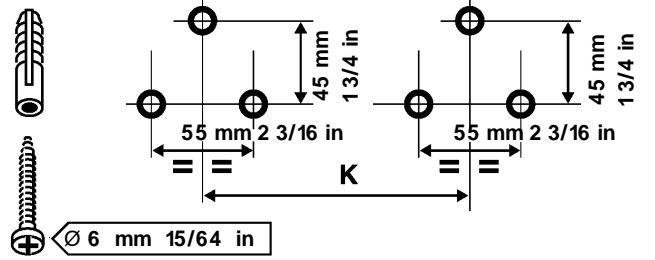
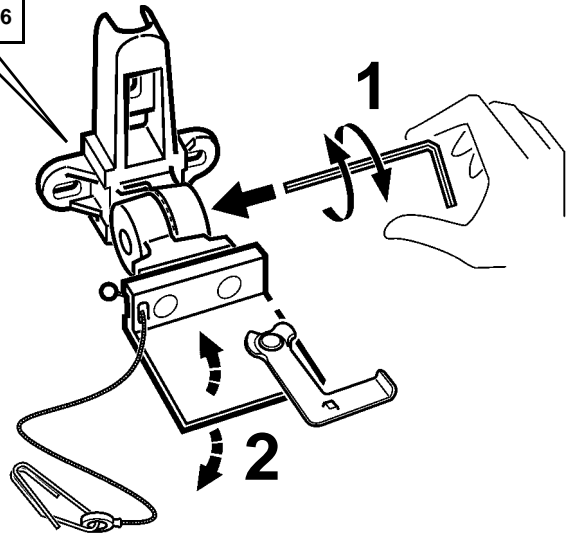

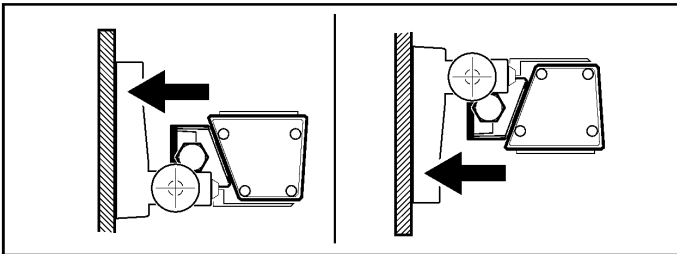

art. 5577

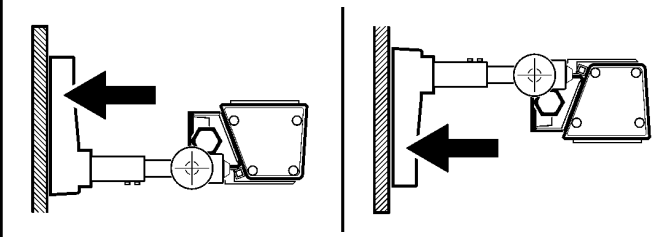
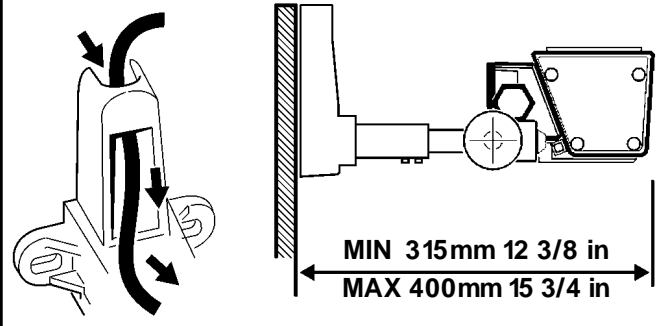
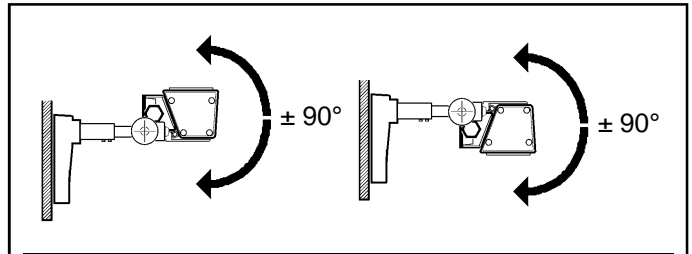
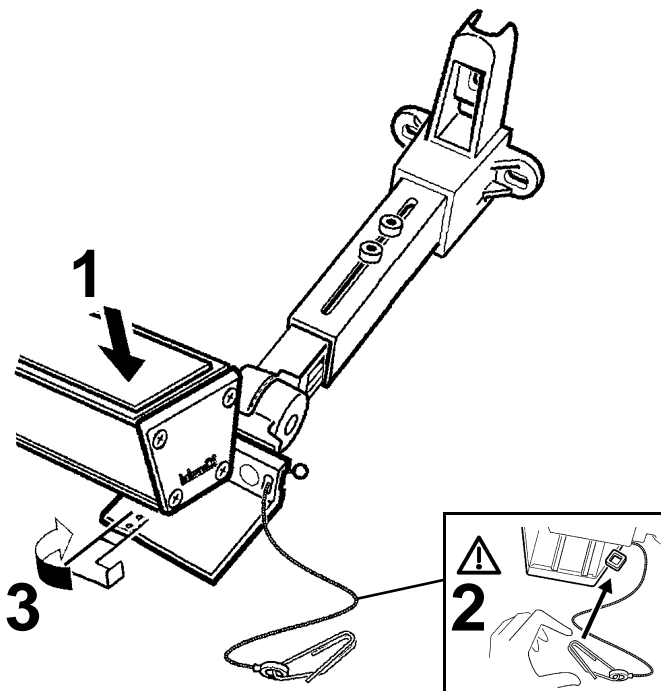
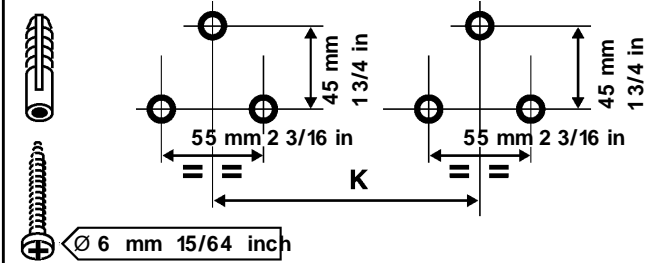
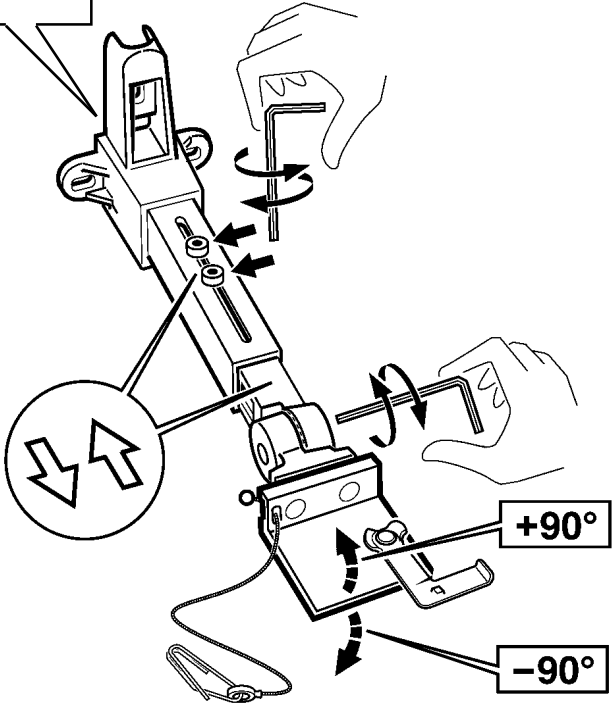

art. 5570 - 5571 - 5576
5577 - 5578 - BZIO
BZ11

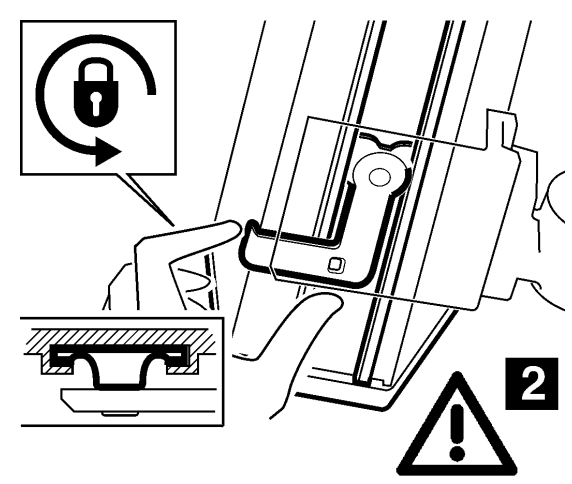
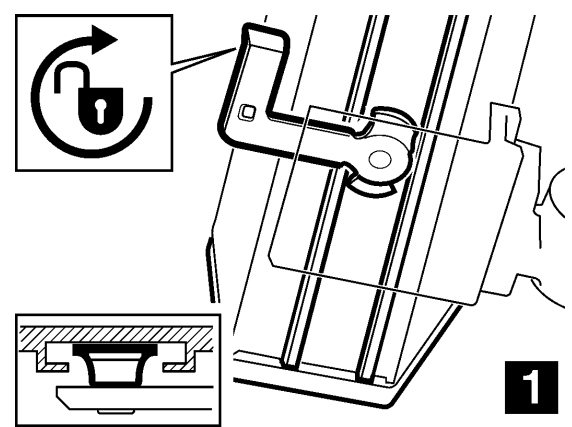

art. BZX2

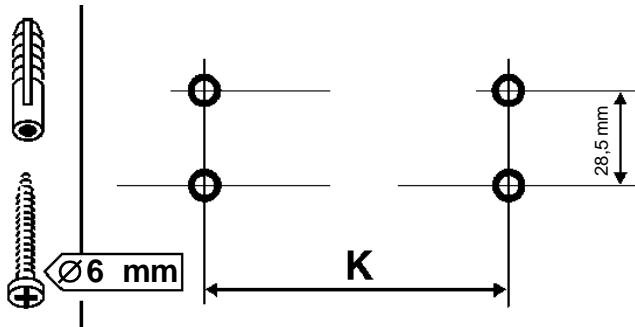
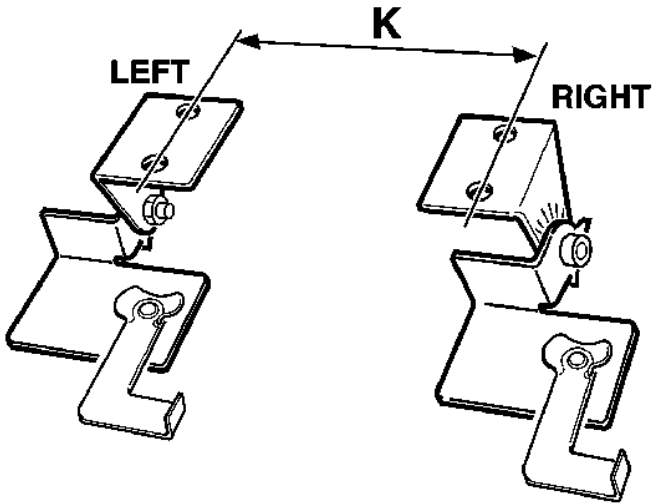

art. BZX3

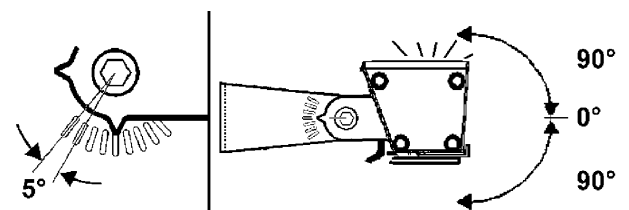
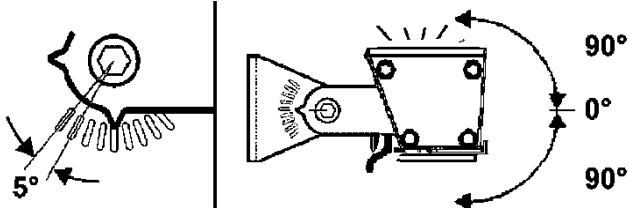
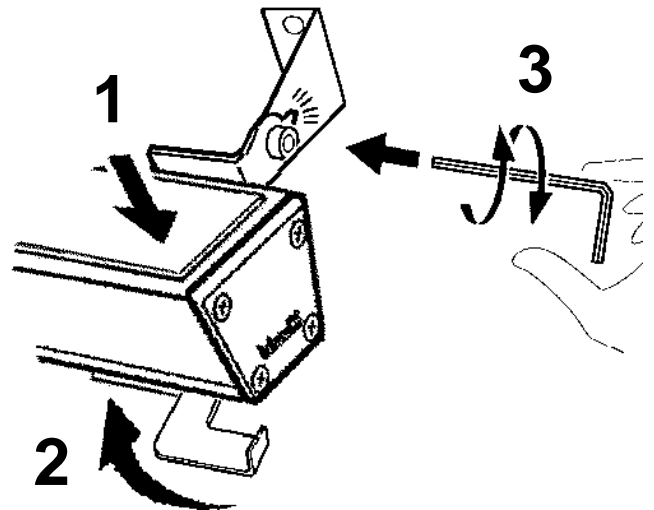
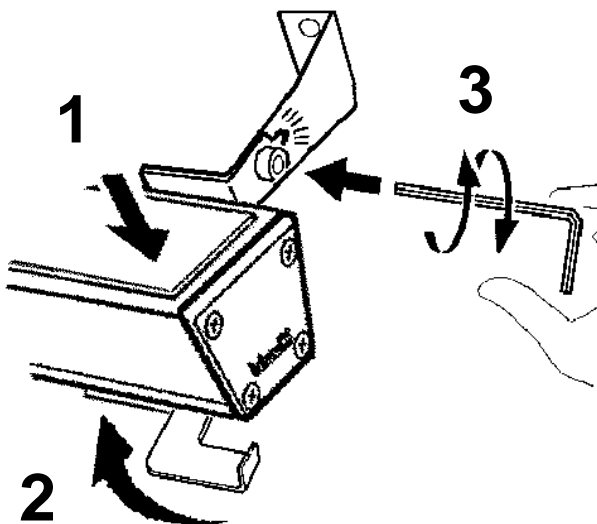
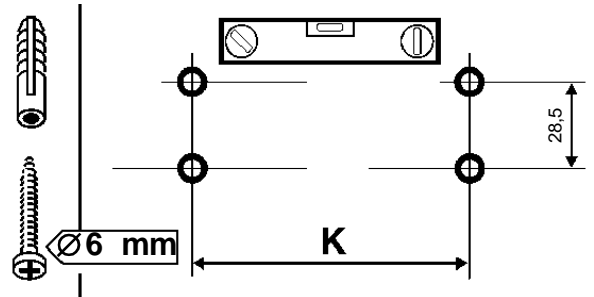
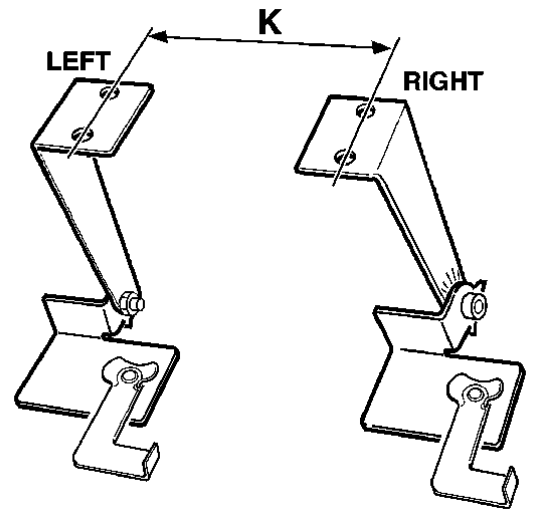

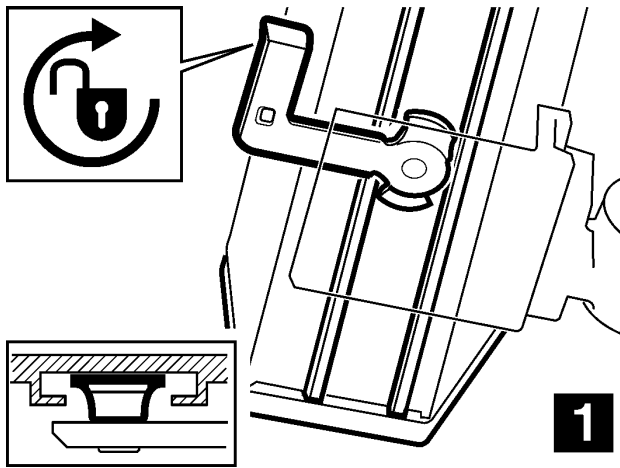

1

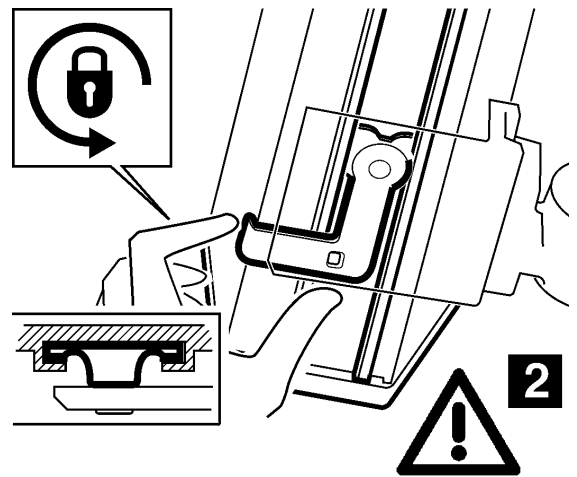

2

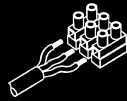

wet location connection or junction box (by others)
connessioni per luoghi umidi o junction box (non fornito)
connexion pour emplacement humide or boîte de jonction (non fourni)
conexión lugar húmedo caja de conexiones(no suministrado)

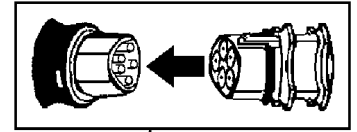
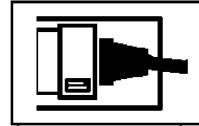
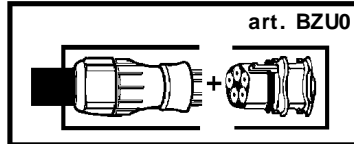
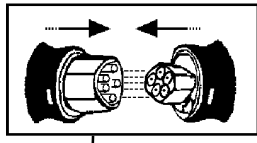
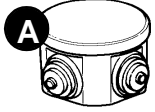

art. BZU2 - BZU3
BZU4

START

END

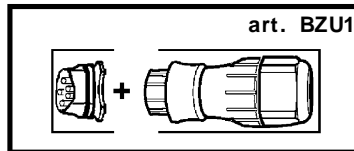
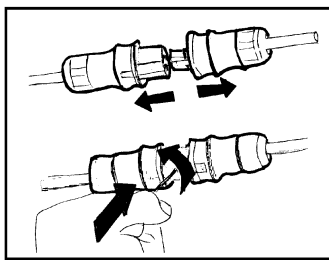

wet location connection or junction box (by others)
connessioni per luoghi umidi o junction box (non fornito)
connexion pour emplacement humide or boîte de jonction (non fourni)
conexión lugar húmedo caja de conexiones(no suministrado)

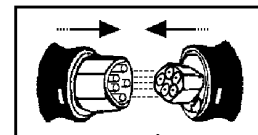
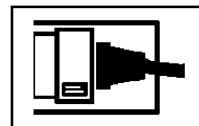
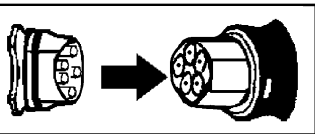
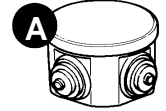

art. BZU2 - BZU3
BZU4

END

START

OK

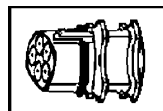

NO

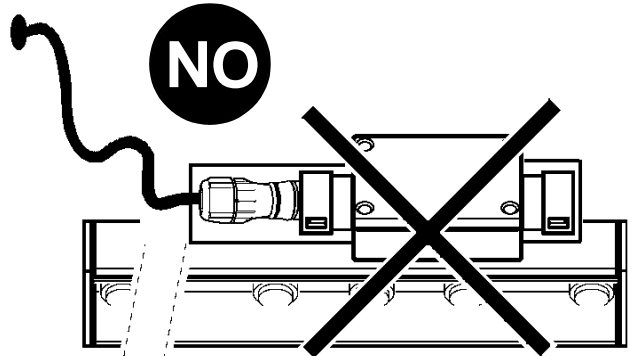

A

GB Make electrical connection: Connect grounding wire (green or bare copper) from the supply circuit to the bare copper wire from the fixture. Connect the white wire(s) from the fixture to the white wire of the supply circuit. Connect the black wire(s) from the fixture to the black wire of the supply circuit. Use U.L. listed wire connectors (by others). Secure wire connectors with U.L. listed electrical tape (by others).

F Réalisez la connexion électrique : reliez le fil de terre (vert ou cuivre nu) du circuit d'alimentation au fil en cuivre nu du luminaire. Reliez le fil (ou les fils) blanc du luminaire au fil blanc du circuit d'alimentation. Reliez le fil (ou les fils) noir du luminaire au fil noir du circuit d'alimentation. Utilisez exclusivement des connecteurs de câbles homologués U.L. (non fournis avec le luminaire). Fixez les connecteurs de câbles à l'aide d'adhésif isolant homologué U.L. (non fourni avec le luminaire).

E Realizar la conexión eléctrica: conectar el conductor de tierra (verde o cobre nudo) del circuito de alimentación con el conductor de cobre nudo del aparato. Conectar el conductor (o los conductores) blanco del aparato al conductor blanco del circuito de alimentación. Conectar el conductor (o los conductores) negro del aparato al conductor negro del circuito de alimentación. Utilizar solamente conectores para cables aprobados U.L. (no suministrados). Fijar los conectores para cables con cinta adhesiva aislante aprobada U.L. (no suministrada).

I Eseguire il collegamento elettrico: collegare il conduttore di terra (verde o rame nudo) del circuito di alimentazione al conduttore in rame nudo dell'apparecchio. Collegare il conduttore (o i conduttori) bianco dell'apparecchio al conduttore bianco del circuito di alimentazione. Collegare il conduttore (o i conduttori) nero dell'apparecchio al conduttore nero del circuito di alimentazione. Utilizzare unicamente connettori per cavi omologati U.L. (non forniti in dotazione). Fissare i connettori per cavi con nastro isolante omologato U.L. (non fornito in dotazione).

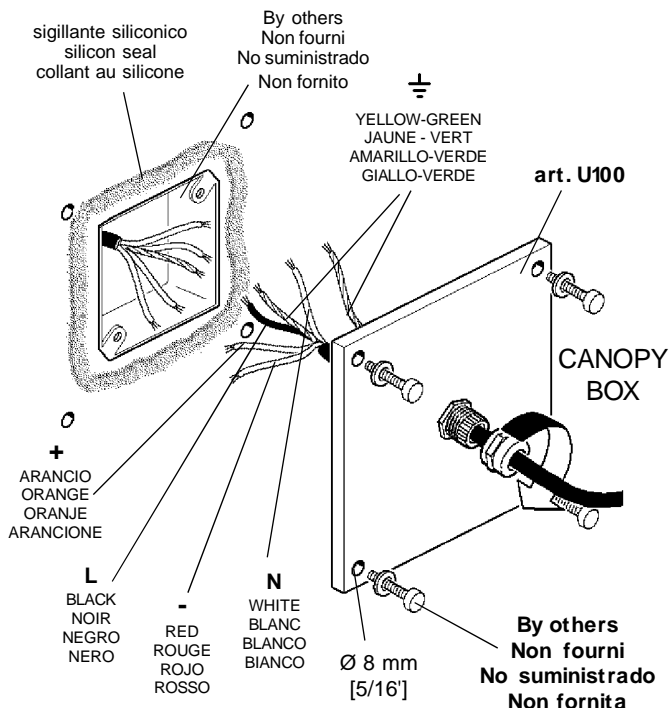
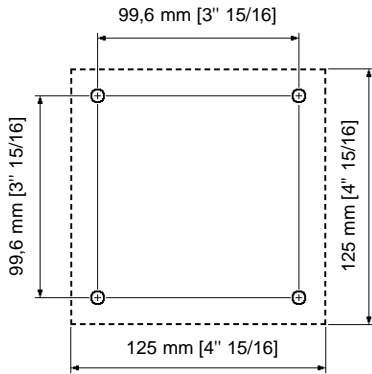

GB IMPORTANT: In order to comply with established electrical code, the installer must seal the area around the fixture canopy and the wall, with type of caulking compound such as GE 100% or Dow Corning 100% silicone to provide a watertight seal in accordance with the differing surface textures of the wall.

F IMPORTANT: Pour assurer la conformité aux normes électriques en vigueur, l'installateur doit isoler la zone autour du couvercle de protection de l'appareil et le mur à l'aide d'une colle pour sceller type silicone 100% GE ou Dow Corning pour assurer l'étanchéité suivant les différentes textures de la surface des murs.

E IMPORTANT: Para garantizar el cumplimiento de las normas vigentes sobre las instalaciones eléctricas el instalador tiene que aislar el área alrededor de la tapa de protección del aparato y la pared con un producto de aislamiento tipo silicona 100% GE o Dow Corning para garantizar la estanqueidad según el tipo de superficie de la pared.

I IMPORTANT: Per garantire la conformità alla normativa vigente in materia di impianti elettrici, l'installatore ha l'obbligo di isolare l'area circostante il coperchio di protezione dell'apparecchio e la parete con un materiale sigillante tipo silicone 100% GE o Dow Corning per garantire la tenuta stagna a seconda della diversa natura della superficie della parete.

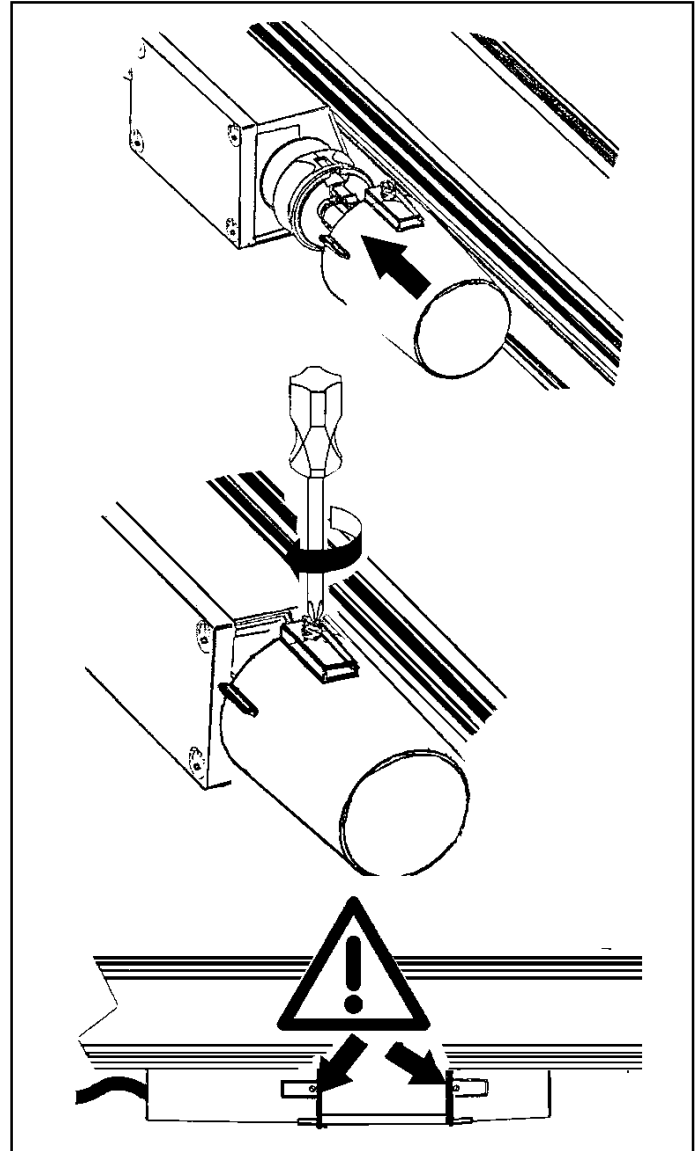

ART.	cable câble cable cavo	X (mm) [in]	L (mm) [in]
BZU2	AWG14	430 [16 15/16]	525 [20 11/16]
BZU3		960 [37 13/16]	1055 [41 9/16]
BZU4		1490 [58 11/16]	1580 [62 3/16]

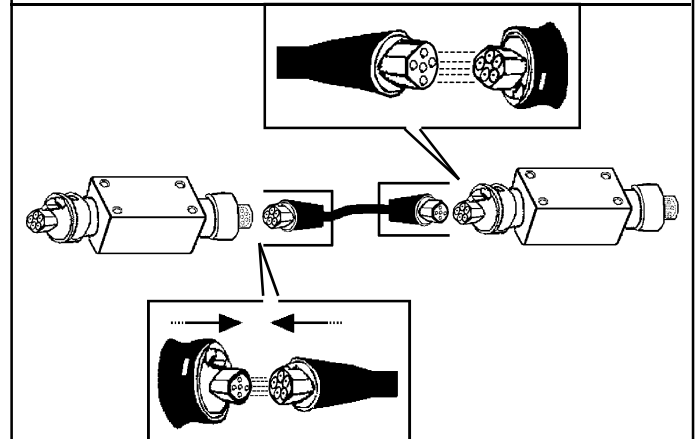
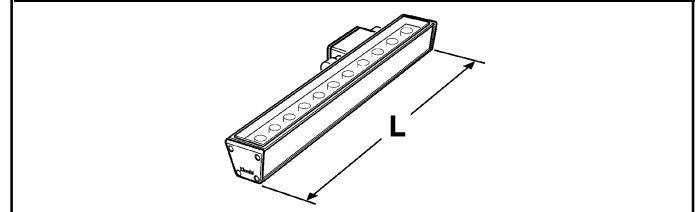

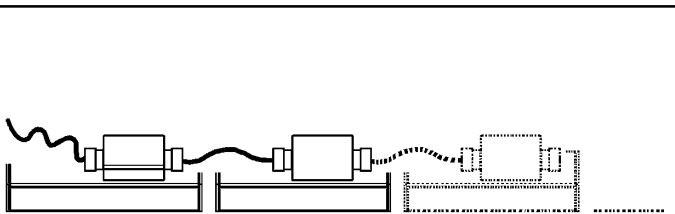

- GB** Calculate the maximum number of products connectable in cascade based on products' consumption, connectors' maximum current, cables' section and length (8A).
- F** Calculer le nombre maximum de produits raccordable en cascade en tenant compte de la puissance absorbée par les luminaires, de la section et de la longueur des câbles ainsi que du courant maximum des connecteurs (8A).
- E** Calcular el número máximo de productos conectables en cascada, teniendo en cuenta la absorción de los productos, la sección de los cables, la longitud de los cables y la corriente máxima de los conectores (8A).
- I** Calcolare il numero massimo dei prodotti collegabili in cascata, tenendo conto dell'assorbimento dei prodotti, della sezione dei cavi, della lunghezza dei cavi e della corrente max dei connettori (8A).

art. BZIO - BZ11 - 5570
5571 - 5576 - 5577
5578

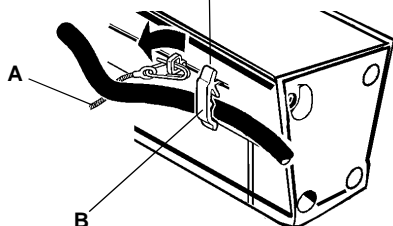
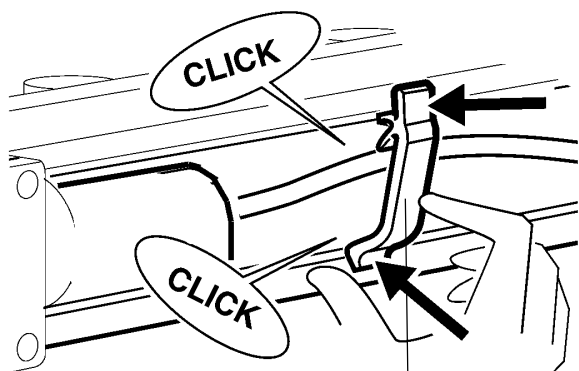

- GB** Before locking the module onto the mechanical support, hook on the steel cables "A" as indicated in the figure. Use the clips "B" to tidy up the electric cables behind the module.
- F** Avant de bloquer le module à son support mécanique, accrochez les filins en acier «A» comme illustré. Utilisez les clips «B» pour bien ranger les câbles électriques derrière le module.
- E** Antes de fijar el módulo al soporte mecánico, enganchar los cables de acero «A» según ilustrado en la figura. Utilizar las clips «B» para el perfecto alojamiento de los cables en el módulo.
- I** Prima di bloccare il modulo al supporto meccanico, agganciare i cavetti d'acciaio "A" come indicato in figura. Utilizzare le clips "B" per sistemare i cavi elettrici perfettamente dietro al modulo.

ART	power factor facteur de puissance factor de potencia fattore di potenza	absorbed current courant absorbé corriente absorbida corrente assorbita (A)	
		120V	277V
BG96	0,74	0,08	0,05
BG97			
BG98			
BG99	0,87	0,14	0,08
BH00	0,87	0,21	0,11
BH01			
BH02	0,92	0,14	0,07
BH03			
BH04			
BH05	0,91	0,26	0,13
BH06	0,90	0,39	0,20
BH07			
BH08	0,82	0,17	0,08
BH09			
BI51			
BI52	0,88	0,35	0,15
BH10			
BH11			
BI53	0,90	0,52	0,23
BI54			
BH12			
BH13	0,90	0,52	0,23
BI55			
BI56			



N.B.: WHEN INSTALLING THE "LINEALUCE LED" SYSTEM, MAKE SURE ALL CURRENT NATIONAL REGULATIONS RELATING TO INSTALLATION ARE OBSERVED.

N.B.: LORS DE L'INSTALLATION DU SYSTÈME "LINEALUCE LED" VEUILLEZ RESPECTER RIGOREUSEMENT LES NORMES EN VIGUEUR EN LA MATIÈRE DANS LE PAYS.

NOTA: DURANTE LA INSTALACIÓN DEL SISTEMA "LINEALUCE LED" RESPETAR ESCRUPULOSAMENTE LAS NORMAS NACIONALES DE INSTALACIÓN EN VIGOR.

N.B.: DURANTE L'INSTALLAZIONE DEL SISTEMA "LINEALUCE LED" RISPETTARE SCRUPOLOSAMENTE LE NORME IMPIANTISTICHE NAZIONALI VIGENTI.



GB Should the glass break, the product cannot be used and you should contact the manufacturer for its replacement.

F En cas d'endommagement de l'écran de protection le produit ne peut pas être utilisé, contactez le fabricant pour le remplacement.

E No utilizar el producto en caso de ruptura del vidrio y contactar el fabricante para la sustitución.

I In caso di rottura del vetro il prodotto non può essere utilizzato, contattare il costruttore per la sua sostituzione.

GB N.B.: For information on LED replacement please contact iGuzzini.

F N.B.: Pour procéder au remplacement de la LED, adressez-vous à la société iGuzzini..

E NOTA: Para sustituir el LED llame a la empresa iGuzzini.

I N.B.: Per la sostituzione del LED contattare l'azienda iGuzzini.

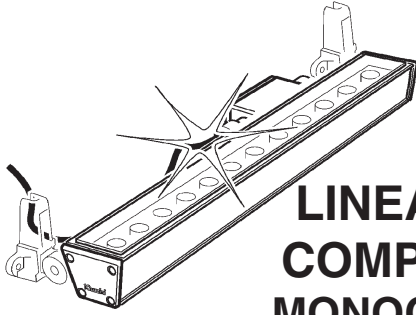

LINEALUCE COMPACT 75 MONOCHROME

تحذير :

لا يمكن ضمان سلامة هذا الجهاز إلا إذا التزمت بهذه التعليمات، يجب حفظها في مكان آمن.

ATTENZIONE:

LA SICUREZZA DELL'APPARECCHIO E' GARANTITA SOLO CON L'USO APPROPRIATO DELLE SEGUENTI ISTRUZIONI; PERTANTO E' NECESSARIO CONSERVARLE.

WARNING:

THE SAFETY OF THIS FIXTURE IS GUARANTEED ONLY IF YOU COMPLY WITH THESE INSTRUCTIONS; REMEMBER TO CONSERVE IN A SAFE PLACE.

ATENCION:

LA SEGURIDAD DEL APARATO SE GARANTIZA SOLO CUMPLIENDO CUIDADOSAMENTE LAS SIGUIENTES INSTRUCCIONES; POR ELLO, ES NECESARIO CONSERVARLAS.

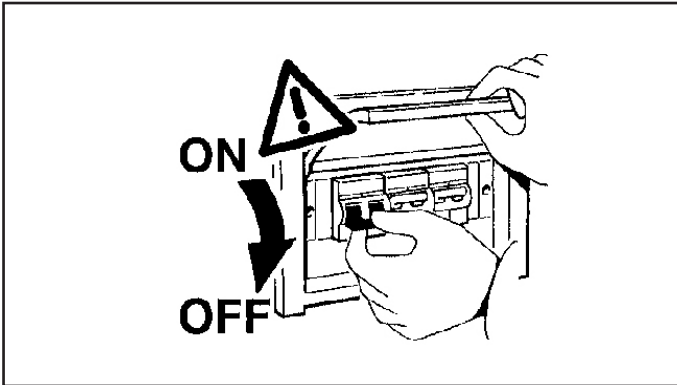

الصنف ART.	L (mm) ملم
BG98 - BG99 - BH04 - BH05 BH10 - BH11 - BI53 - BI54	1056
BH00 - BH01 - BH06 - BH07 BH12 - BH13 - BI55 - BI56	1585

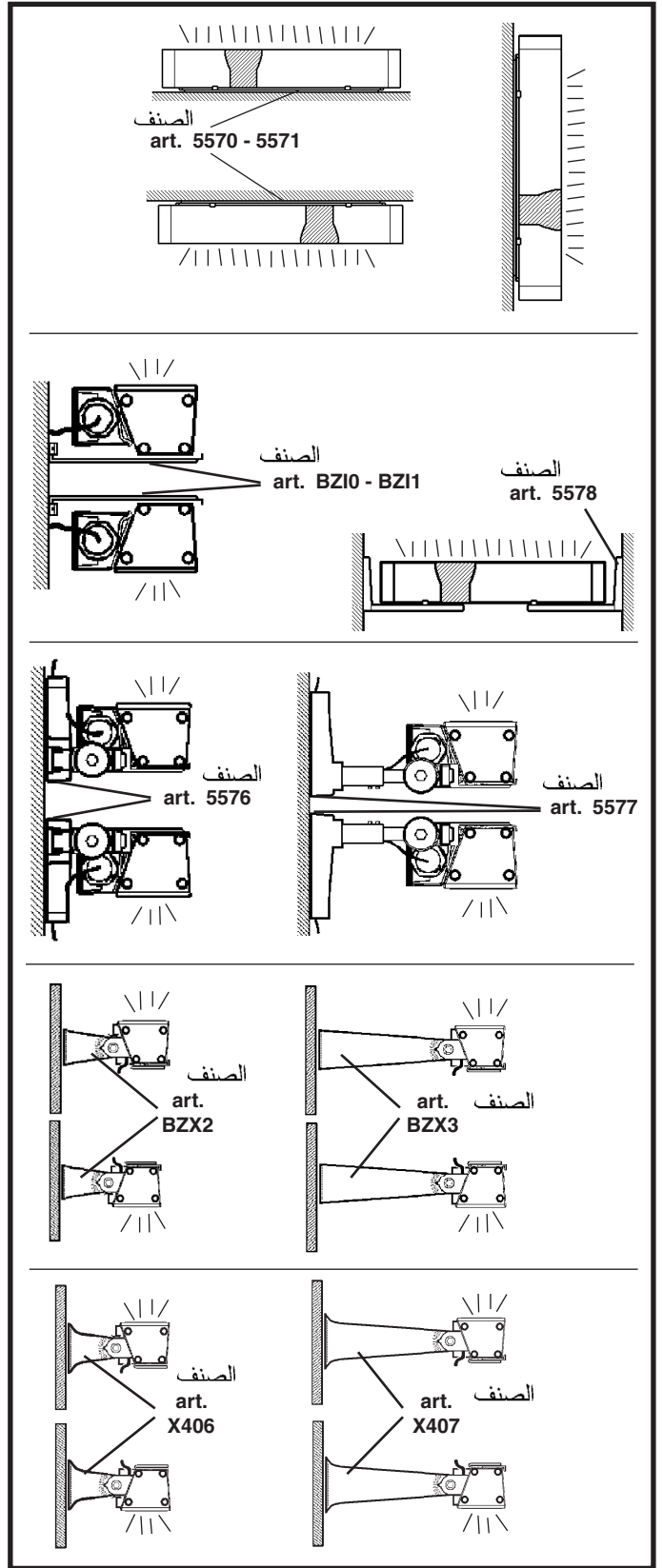
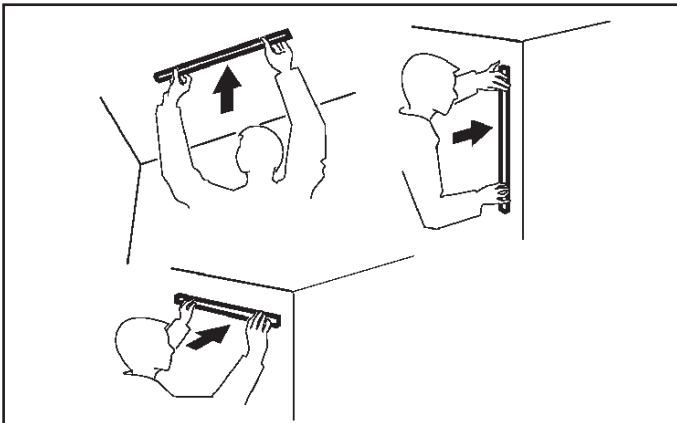

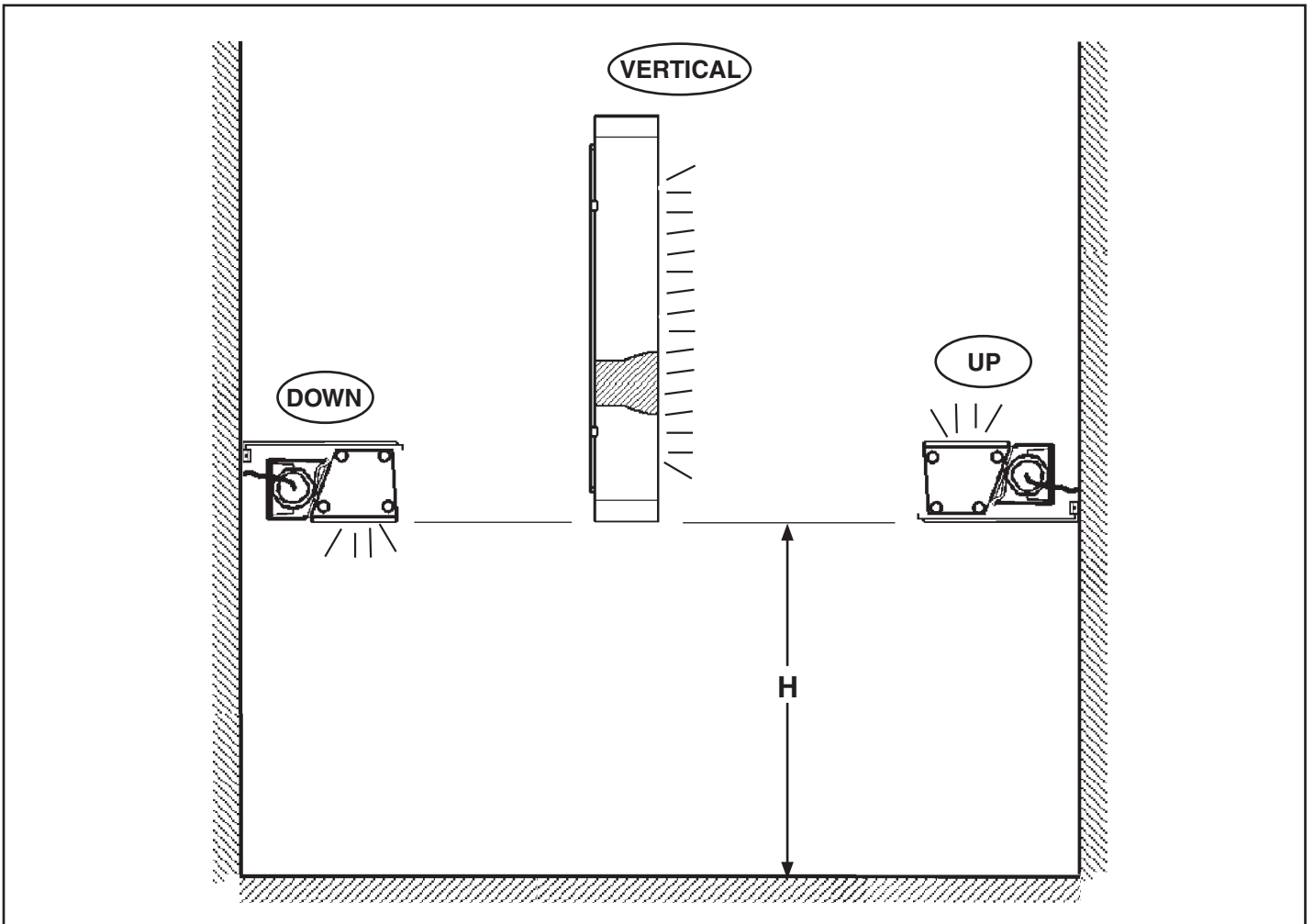

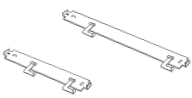
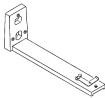
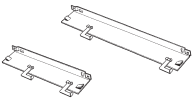
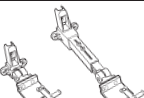
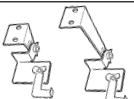
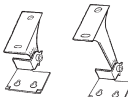
ACCESSORIES		H > 3m			H < 3m		
الاصنف art.		UP	DOWN	VERTICAL	UP	DOWN	VERTICAL
	5570 - 5571	✓	✗	✗	✓	✓	✓
	5578	✓	✗	✗	✓	✗	✗
	BZ10 - BZ11	✓	✗	✗	✓	✓	✗
	5576 - 5577	✓	✗	✗	✓	✓	✗
	BZX2 - BZX3	✓	✗	✗	✓	✓	✗
	X406 - X407	✓	✓	✗	✓	✓	✗

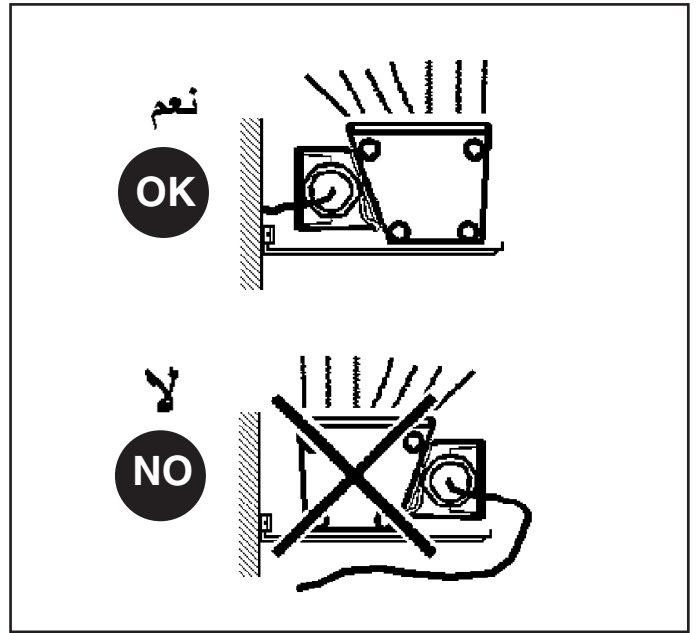
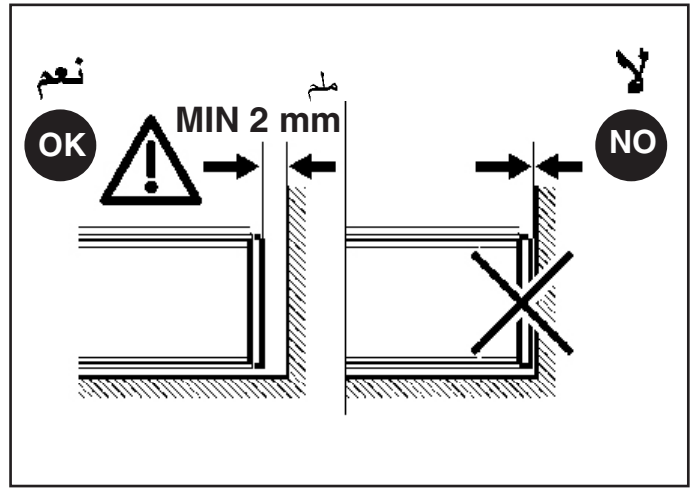
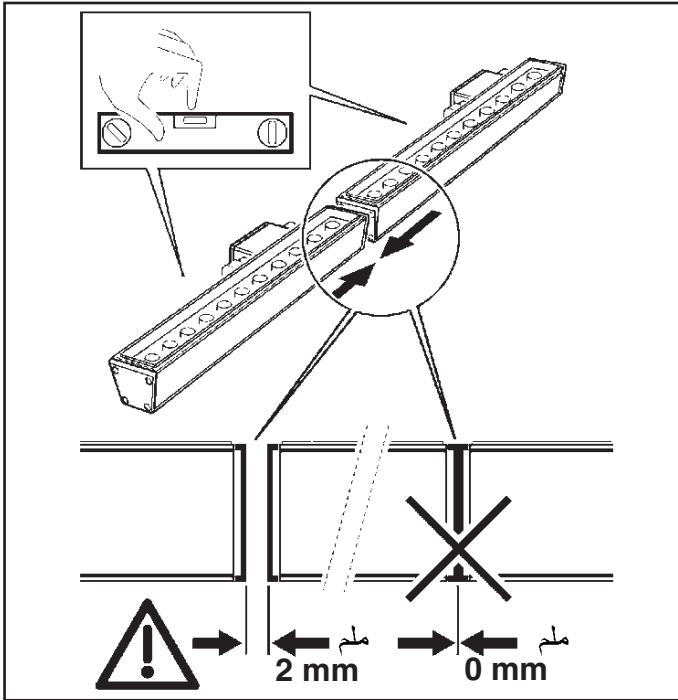
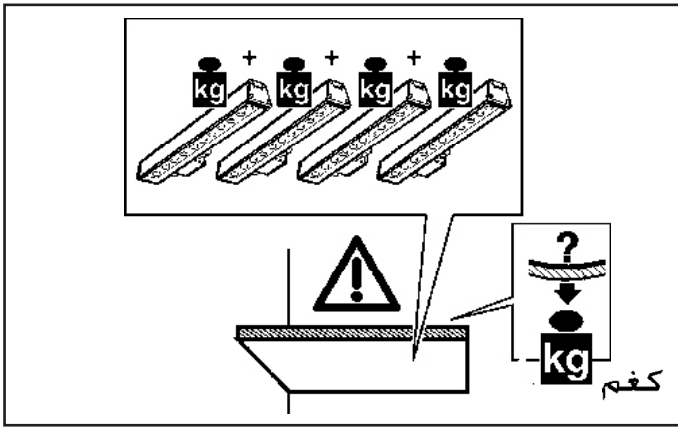

تركيب الدعام الميكانيكية

INSTALLAZIONE DEI SUPPORTI MECCANICI - INSTALLATION OF THE MECHANICAL SUPPORTS
INSTALACION DE LOS SOPORTES MECANICOS

جدول مسافات الفتحات من المركز للمركز

TABELLA INTERASSI DI FORATURA - TABLE CENTRE TO CENTRE DISTANCE BETWEEN HOLES
TALADRAR DISTANCIA ENTRE LOS EJES DE PERFORACION

ملم L (mm)	الصف ART.	ملم K(mm)	ملم K(mm)	ملم K(mm)	ملم K(mm)	ملم K(mm)	ملم Y(mm)	ملم K(mm)
528	BG96 - BG97 - BH02 - BH03 - BH08 - BH09 - BI51 - BI52	240	-	265	396	440	-	600 ÷ 900
1056	BG98 - BG99 - BH04 - BH05 - BH10 - BH11 - BI53 - BI54	240	600	265	924	970	-	1094 ÷ 1474
1585	BH00 - BH01 - BH06 - BH07 - BH12 - BH13 - BI55 - BI56	240	600	600	1453	1500	750	1622 ÷ 2002

ART. 5576 - 5577 - BZX2 - BZX3 - X406 - X407

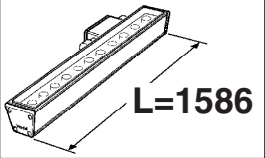

NO لا

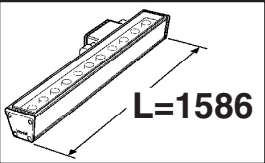
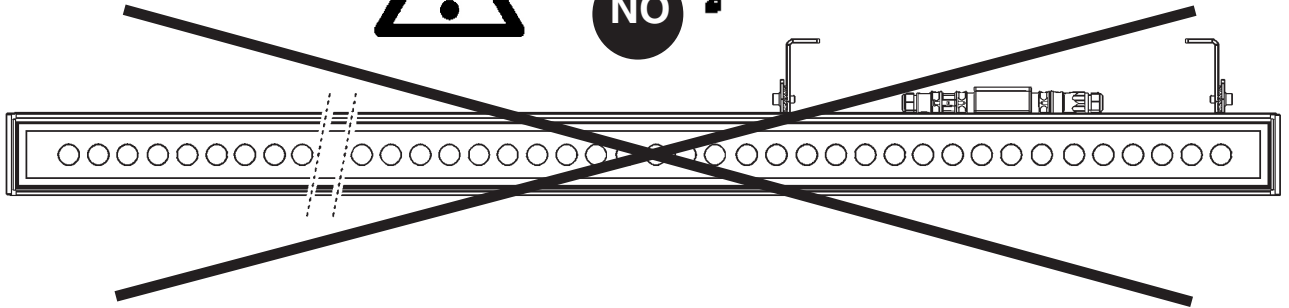

نعم
OK

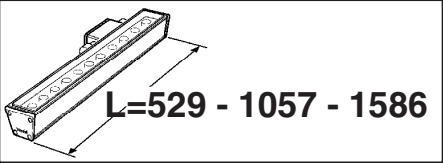
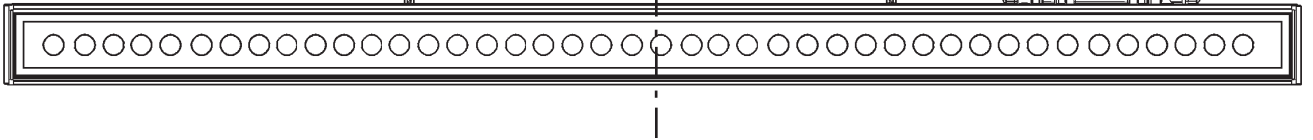
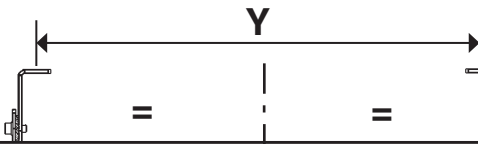

نعم
OK

K

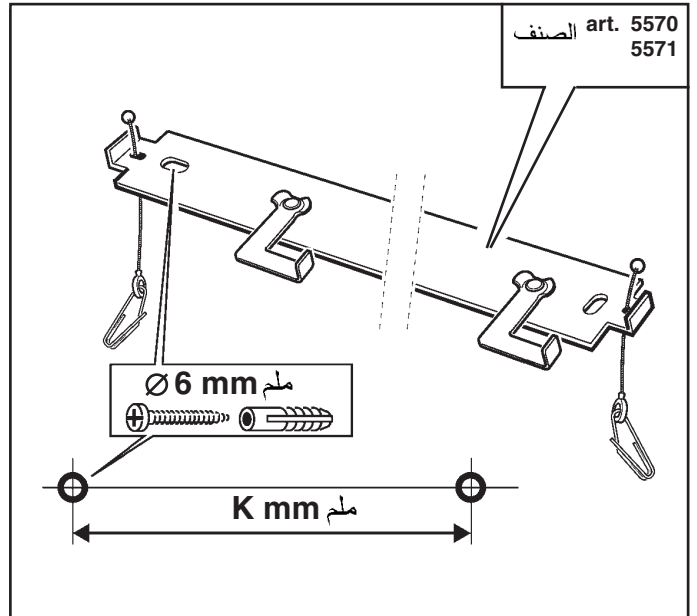
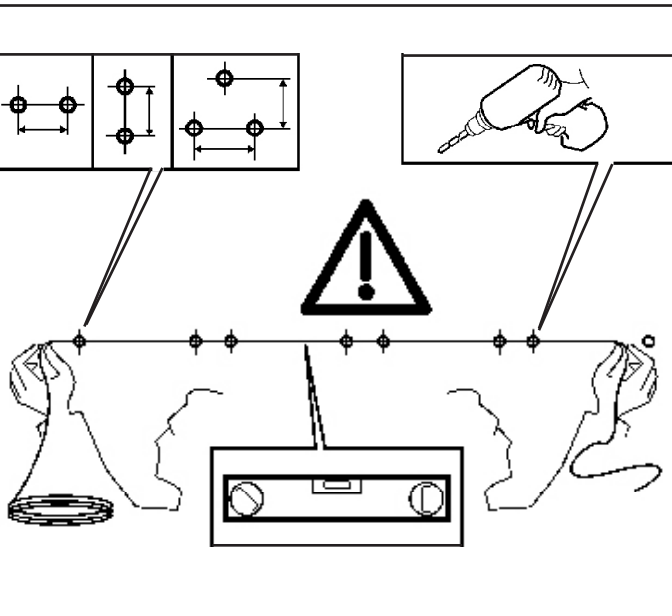
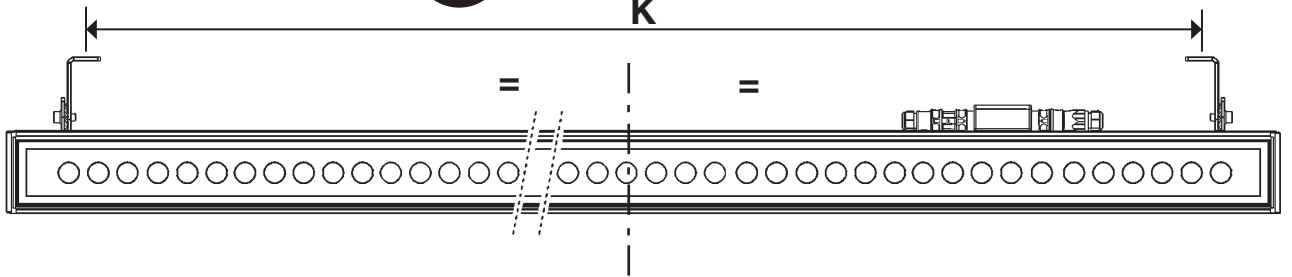

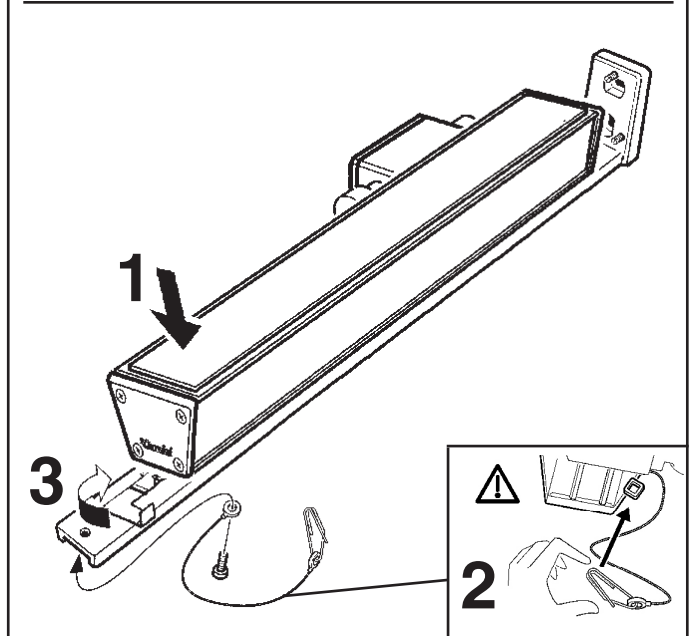
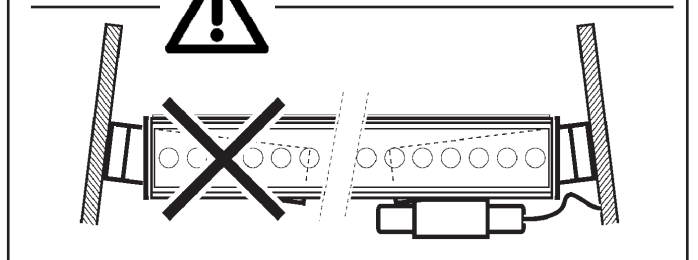
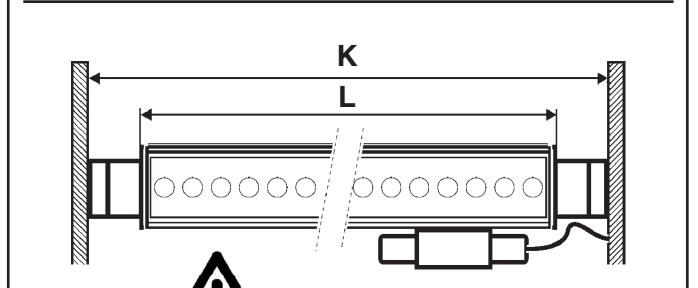
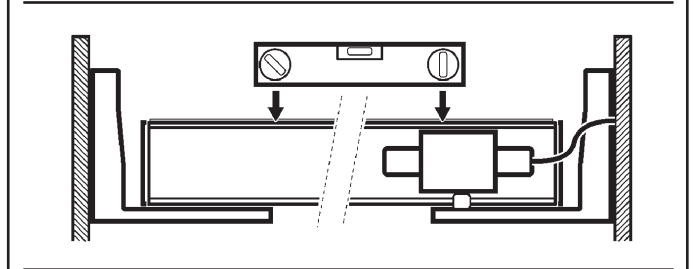
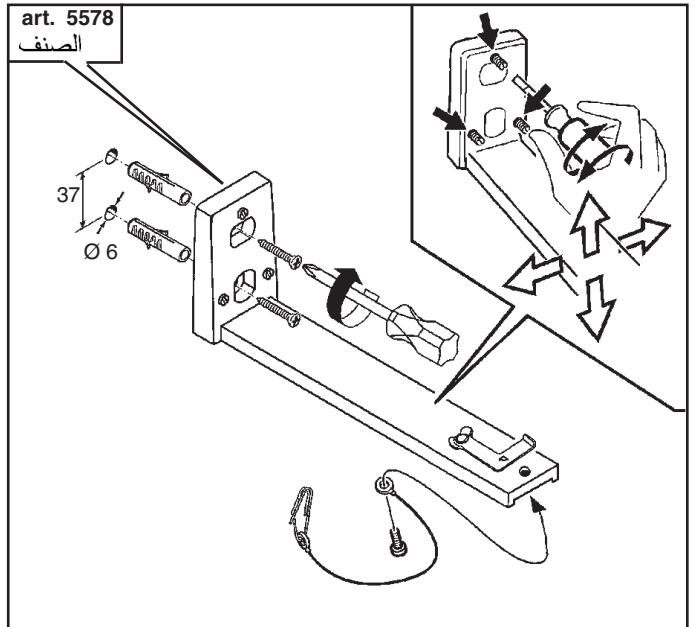
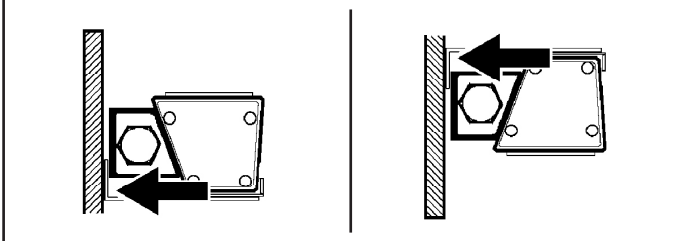
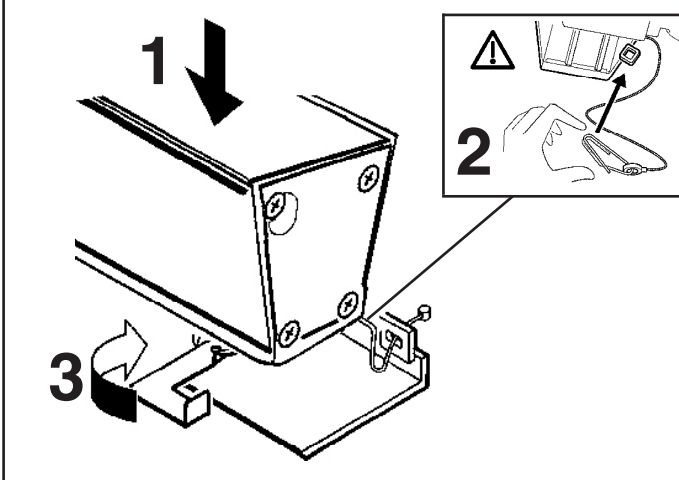
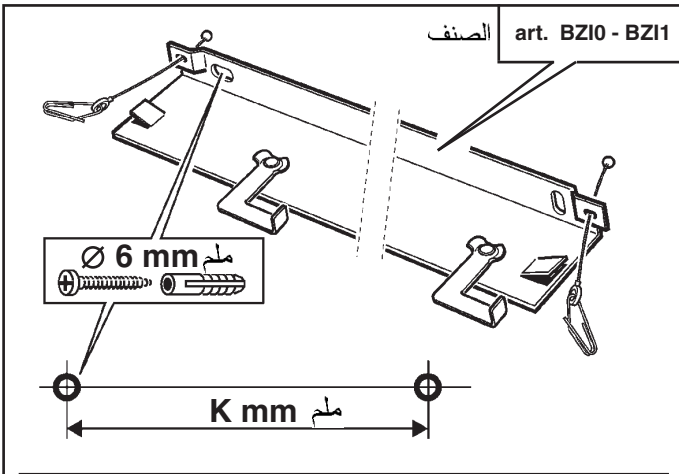
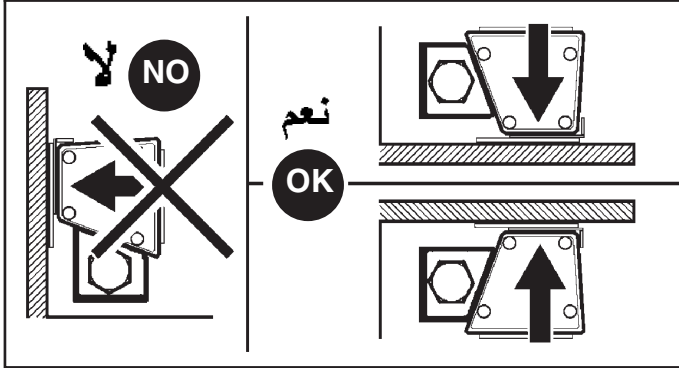
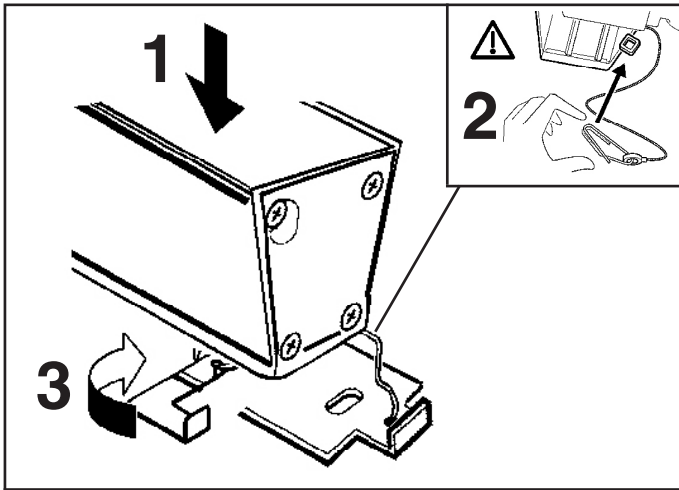

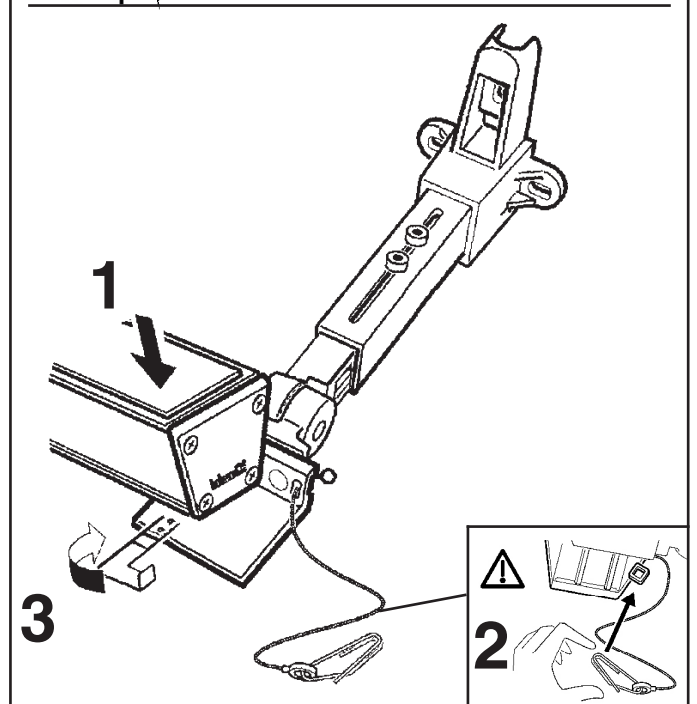
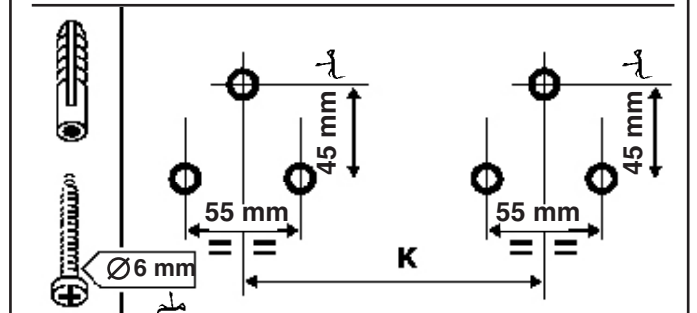
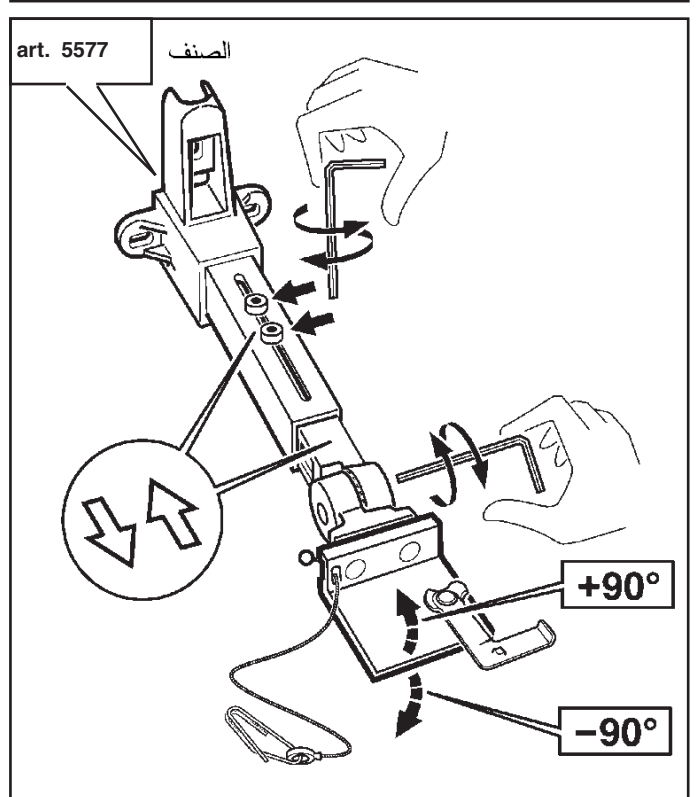
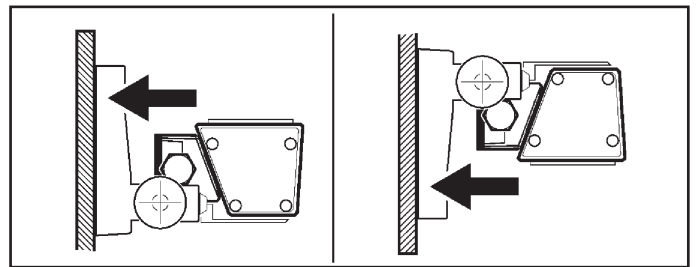
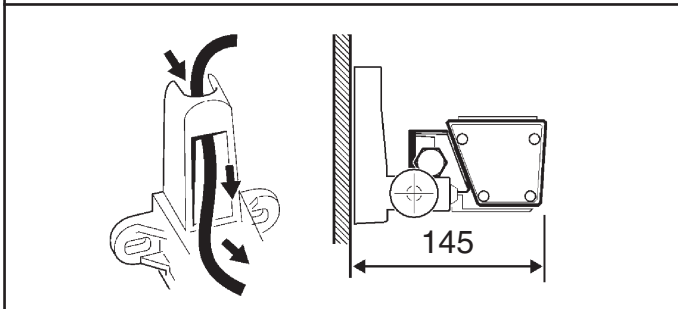
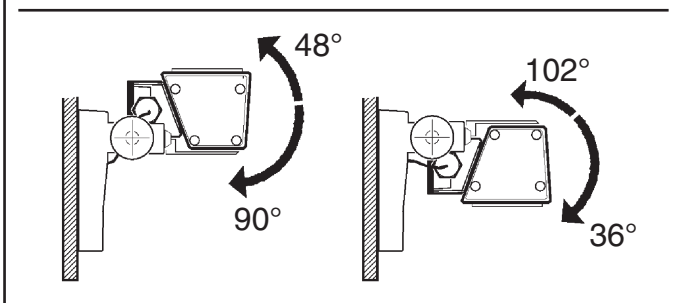
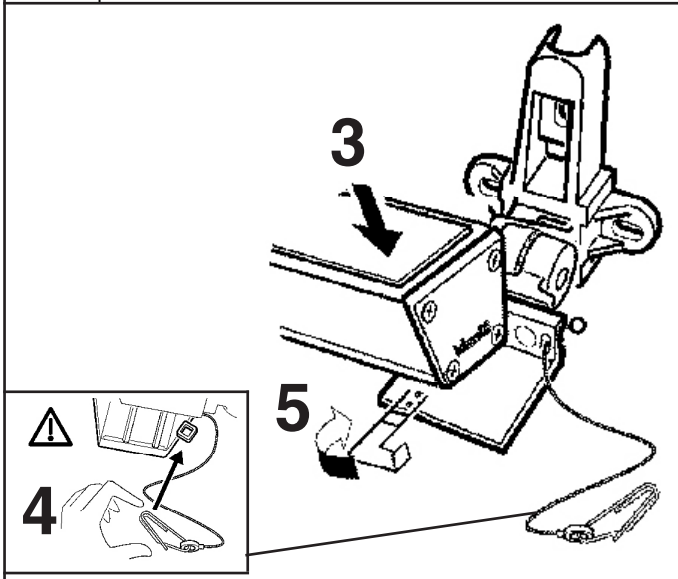
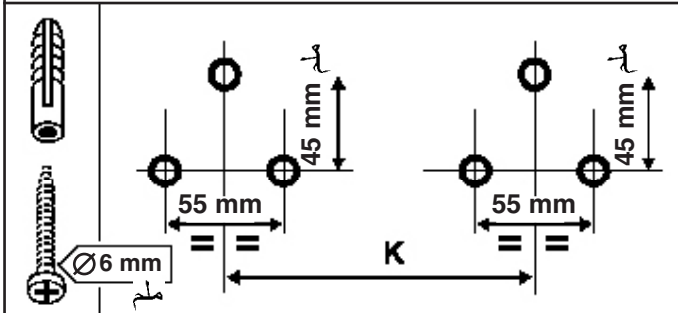
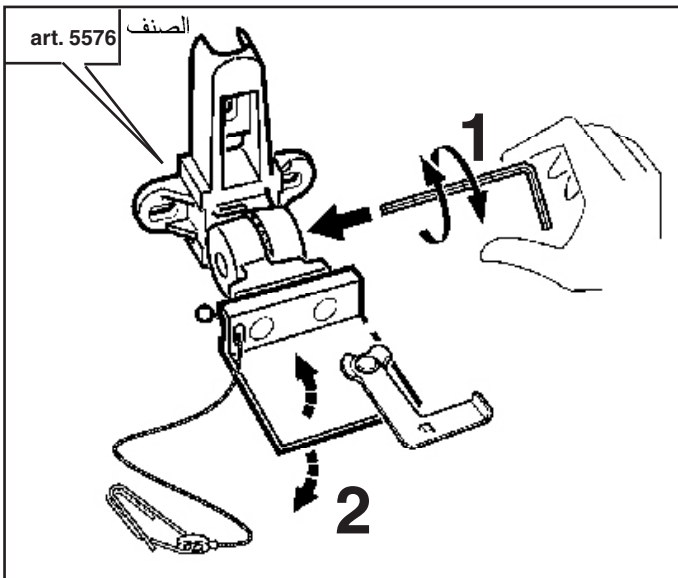

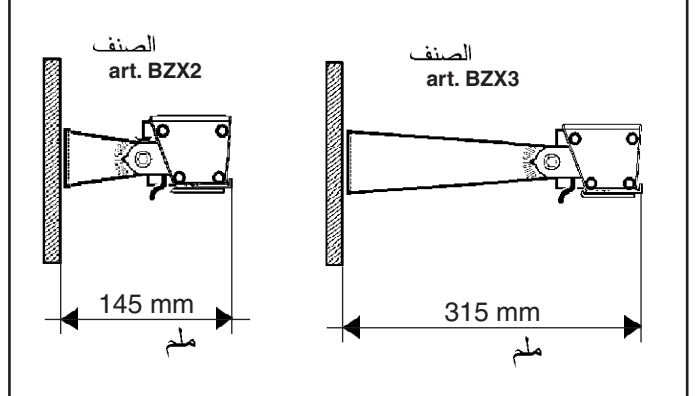
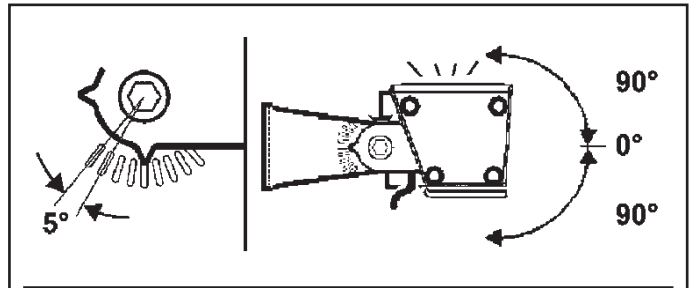
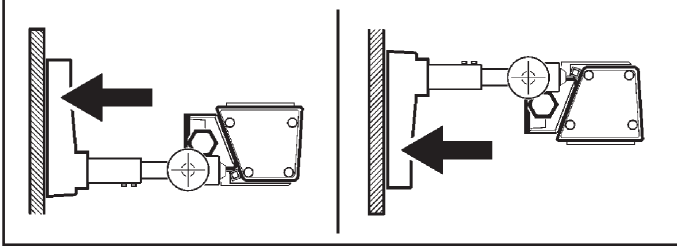
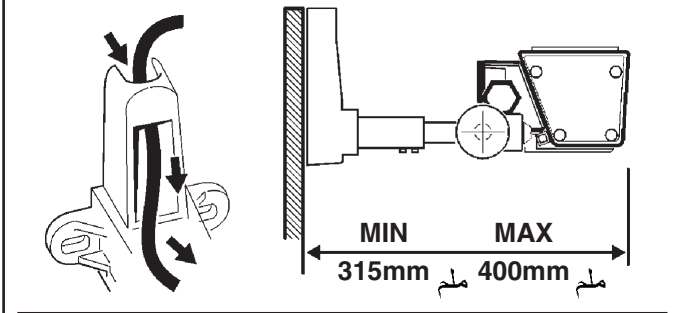
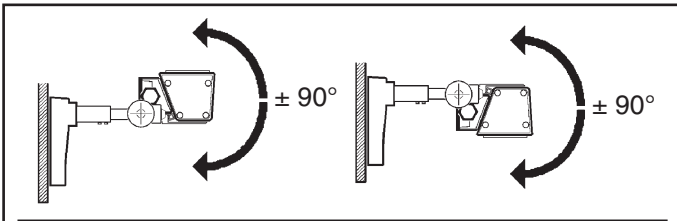

الصف art. 5570 - 5571 - 5576 - 5577 - 5578 - BZIO
BZI1 - BZX2 - BZX3

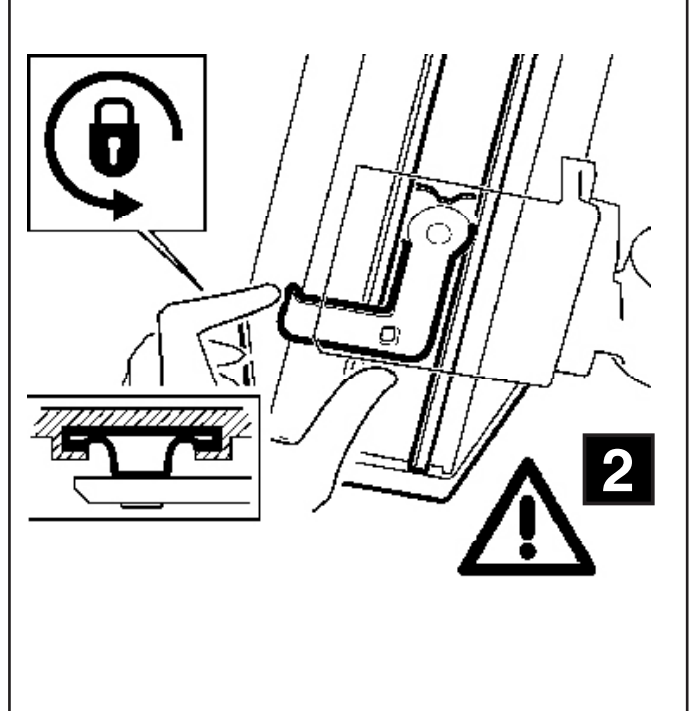
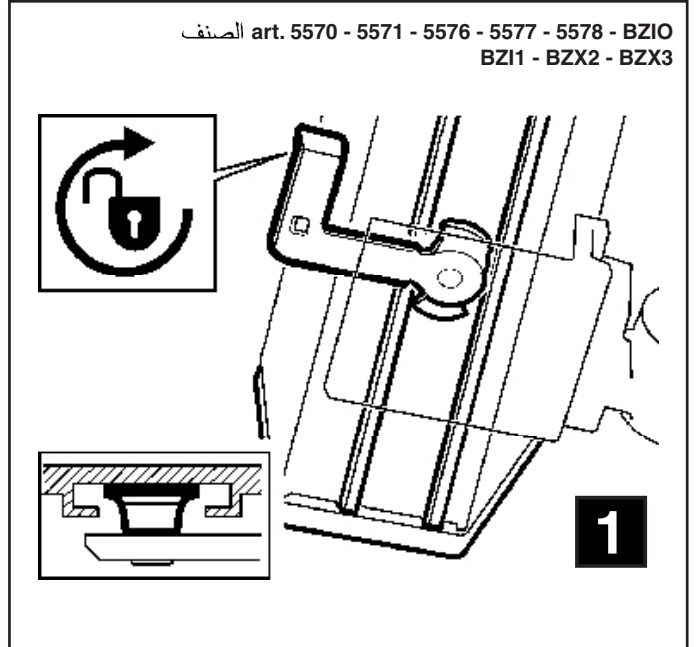
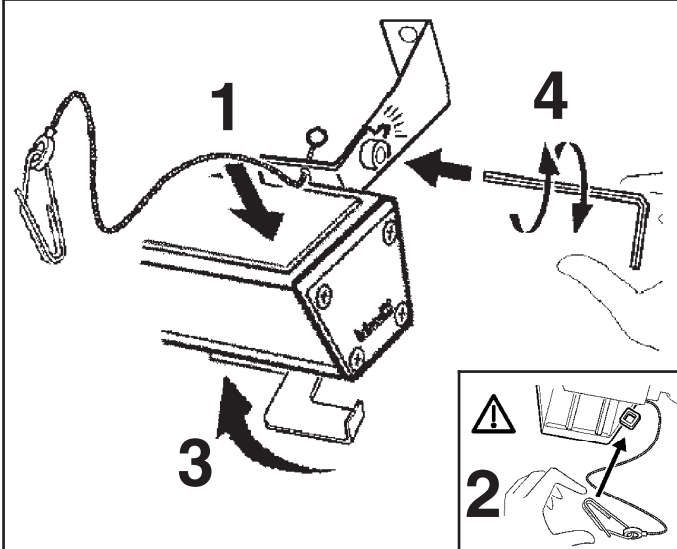
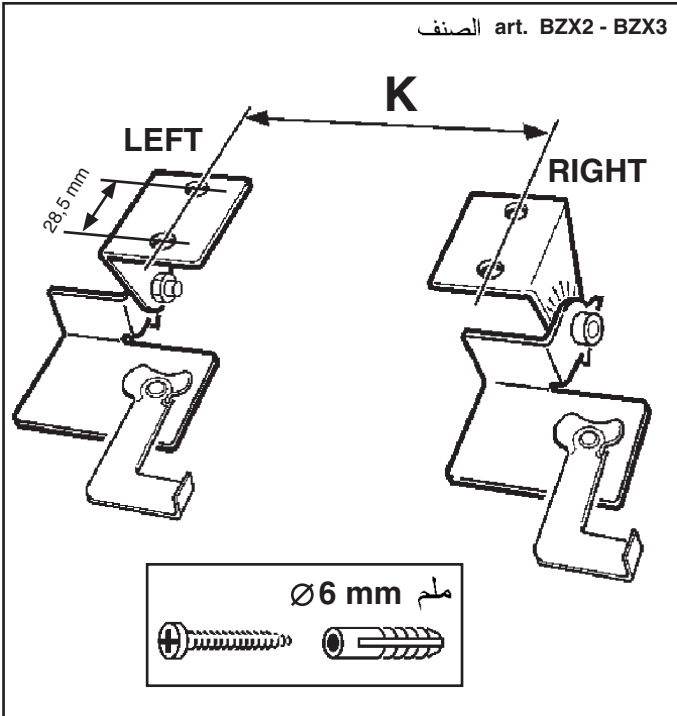

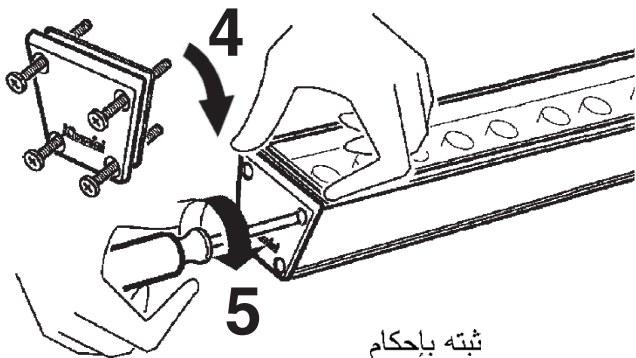
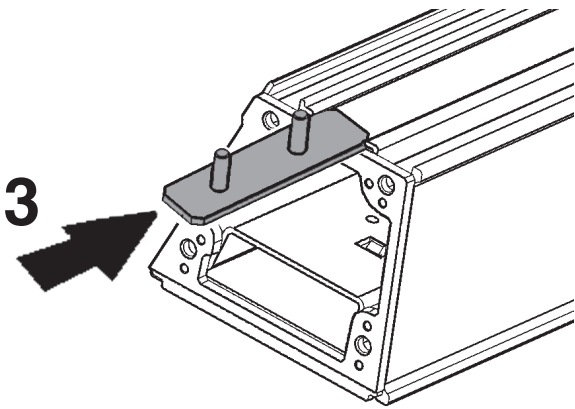
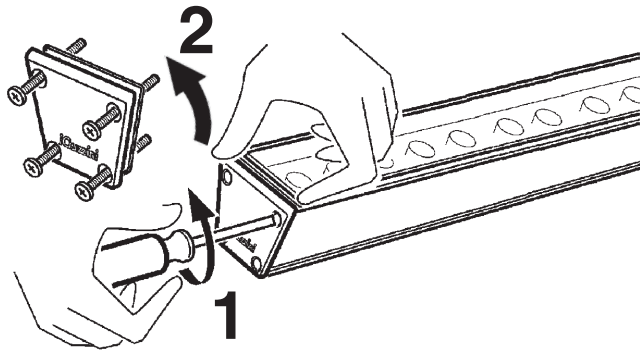
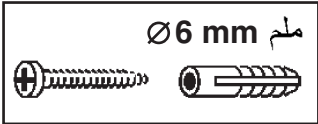
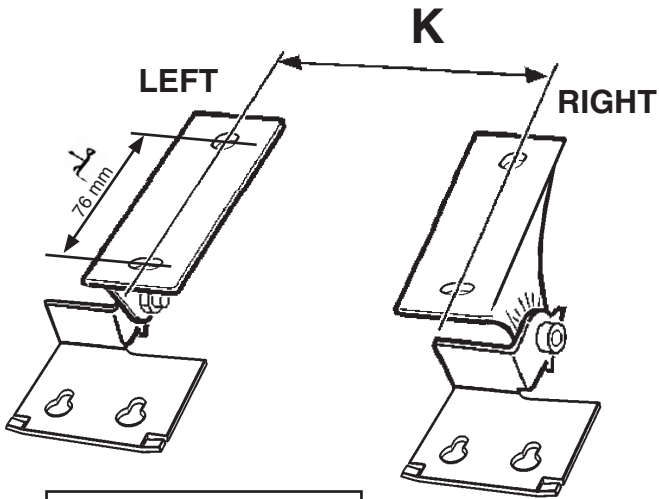

ثبته بإحكام
Serrare a fondo
Tighten firmly
Enroscar en firme

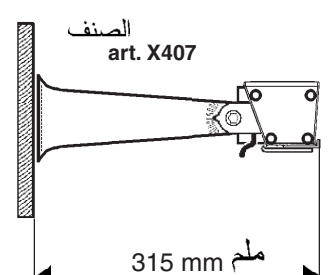
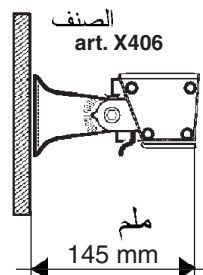
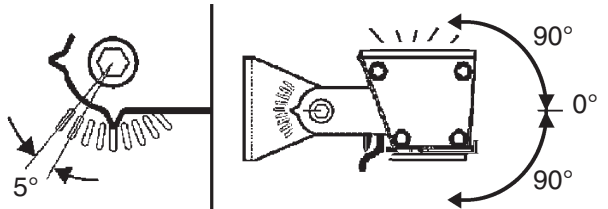
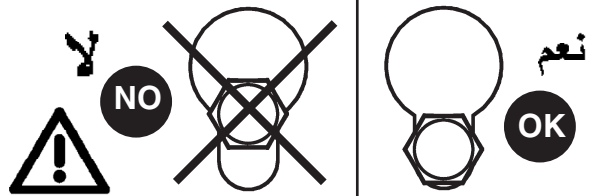
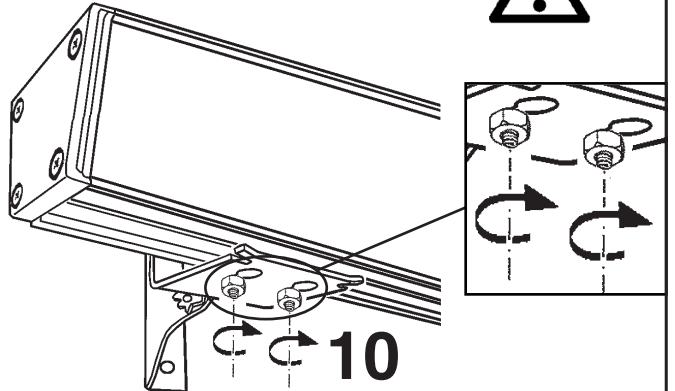
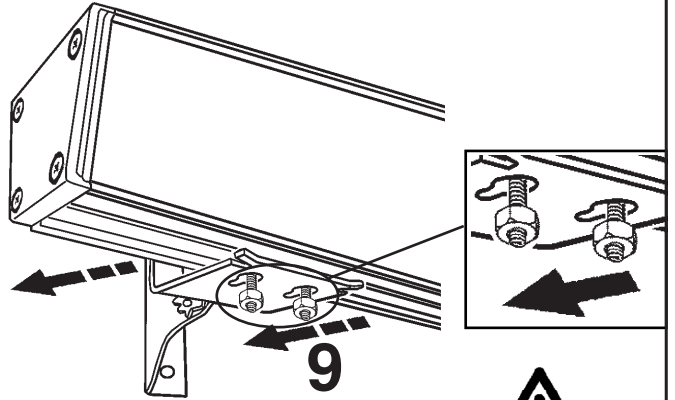
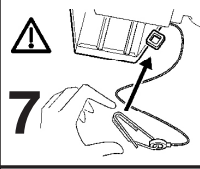
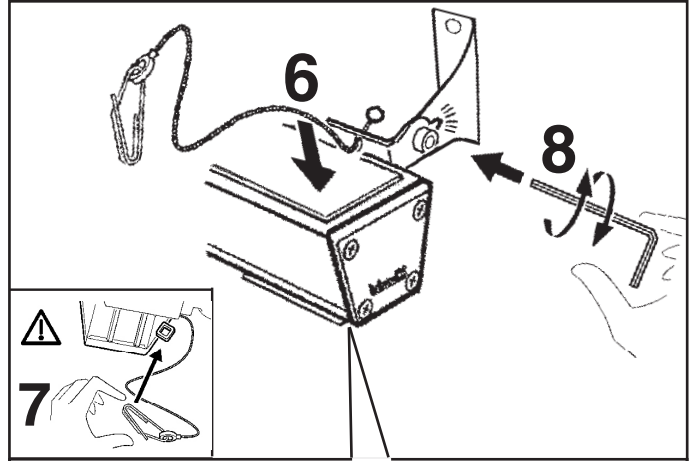

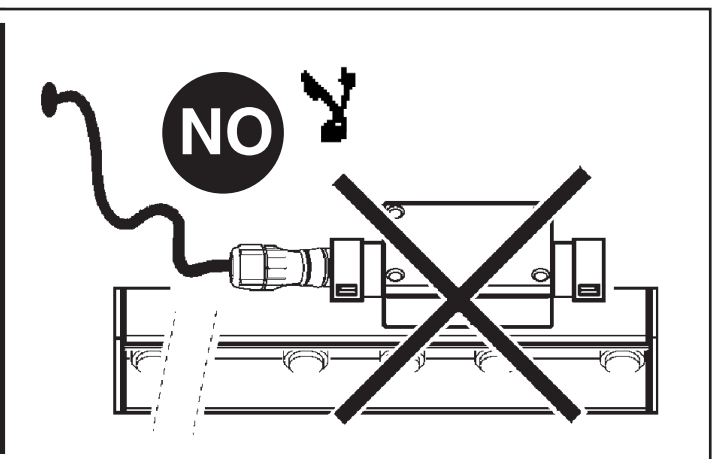
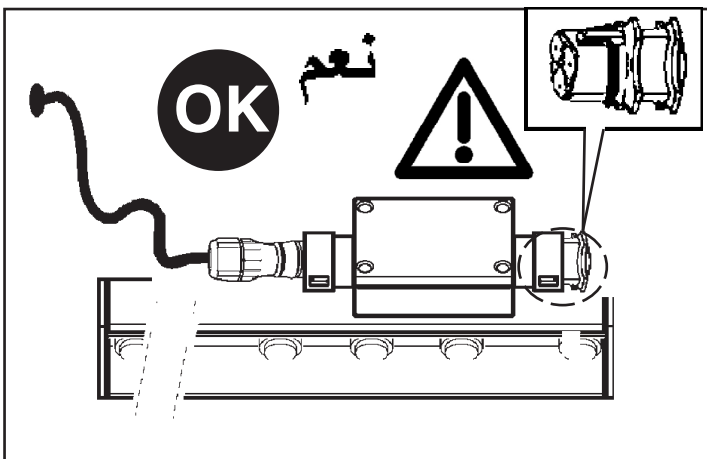
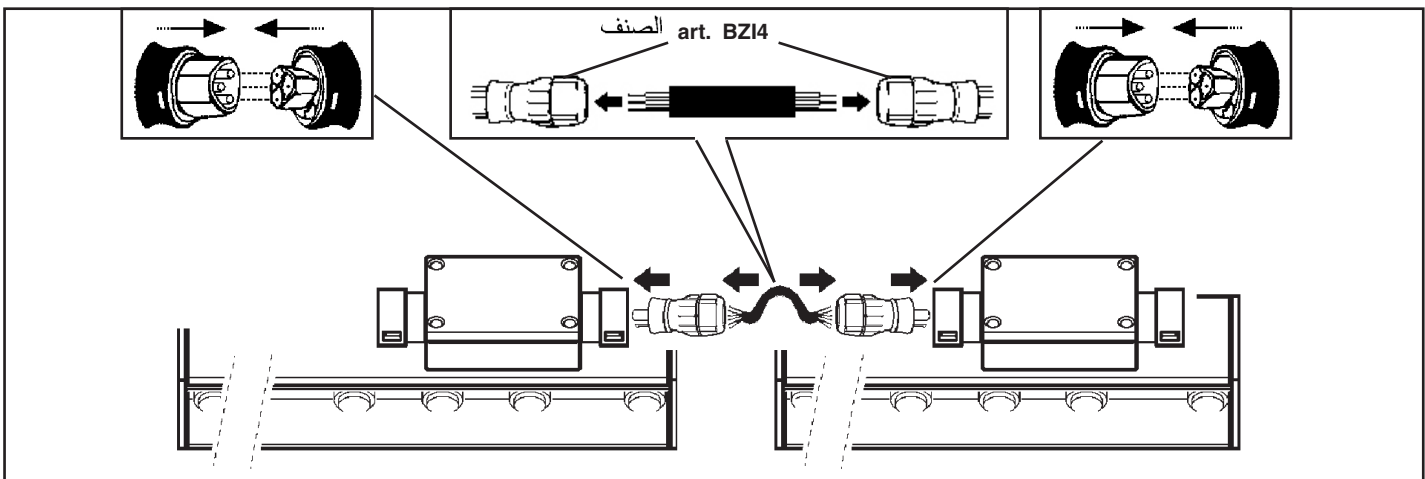
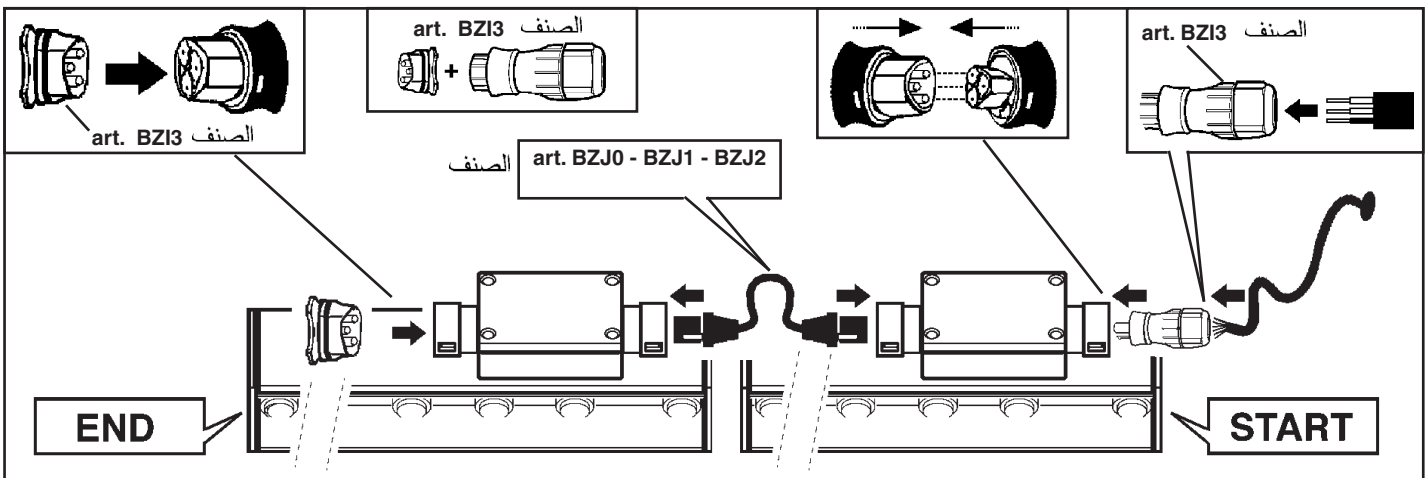
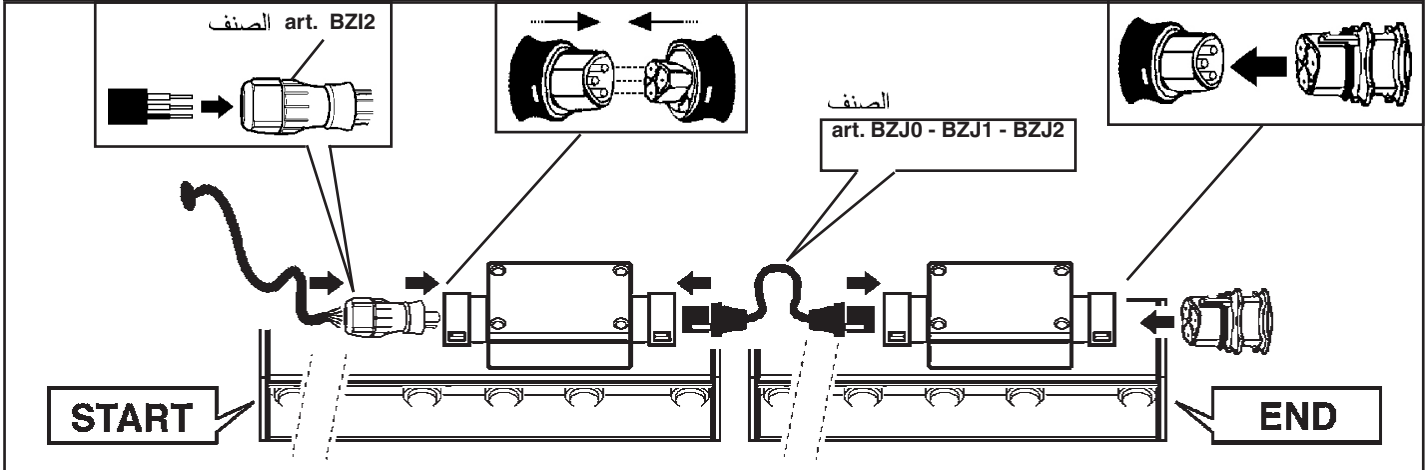
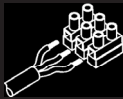

الصنف ART.	عدد الأقطاب n° poli n° poles n° polos	كابل cavo cable cable	المقطع Sezione Section Sección
BZI2	3	ملم Ø(mm)	ملم ² (mm ²)
BZI3		10 ÷ 14mm	2,5 ÷ 4 mm ² ملم ² (max 6A / mm ²)
BZI4			

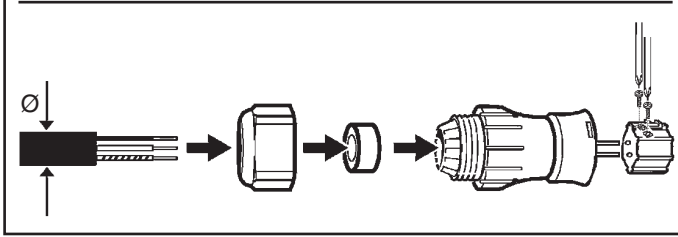
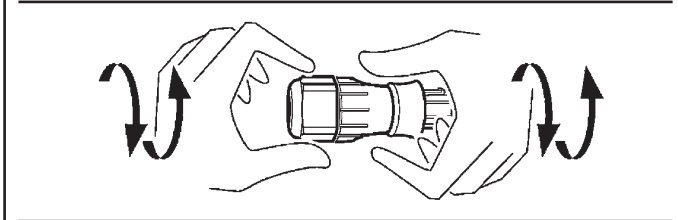
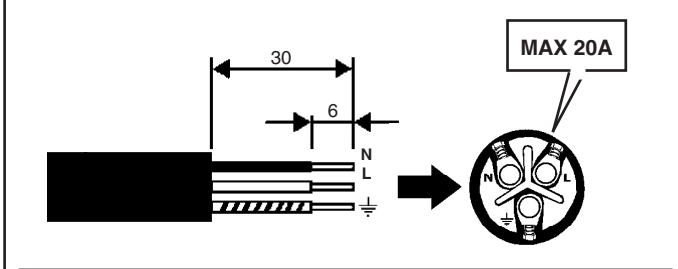

الصنف ART.	كابل cavo cable cable	X (mm) ملم	L (mm) ملم
BZJO	3x2,5mm ² (max 15A)	430	525
BZJ1		960	1055
BZJ2		1490	1580

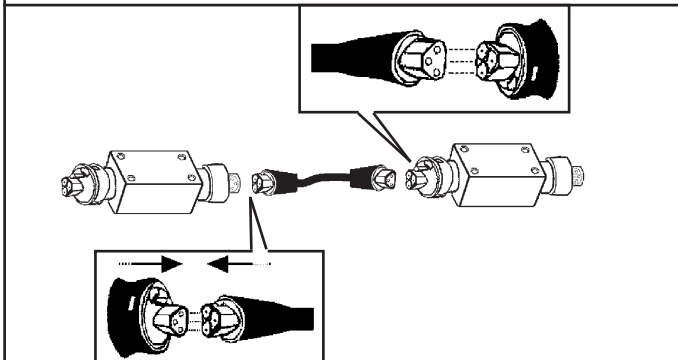
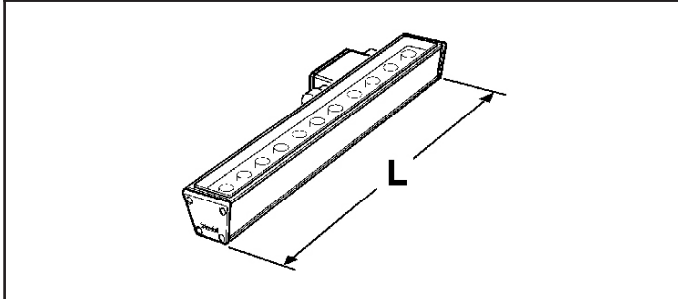

قم بحساب أقصى عدد من المنتجات التي يمكن توصيلها متعاقبة، مع الأخذ في الاعتبار لقدرة التيار الممتصة من الأجهزة، ومقطع الكابل، وطول الكابلات وأقصى تيار للموصلات.

I Calcolare il numero massimo dei prodotti collegabili in cascata, tenendo conto dell'assorbimento dei prodotti, della sezione dei cavi, della lunghezza dei cavi e della corrente max dei connettori .

GB Calculate the maximum number of products connectable in cascade based on products' consumption, connectors' maximum current, cables' section and length.

E Calcular el número máximo de productos conectables en cascada, teniendo en cuenta la absorción de los productos, la sección de los cables, la longitud de los cables y la corriente máxima de los conectores.

تعامل مع المنتج بعناية وحرص، ولا تُعرّضه للإجهادات الميكانيكية

I Maneggiare con cura e non sottoporre a tensioni meccaniche.

GB Handle with care and do not subject to mechanical stress.

E Manejar con cuidado y no someter a tensiones mecánicas.

الصفحة art. BZIO - BZ11 - 5570
5571 - 5576 - 5577
5578 - BXZ2
BXZ3

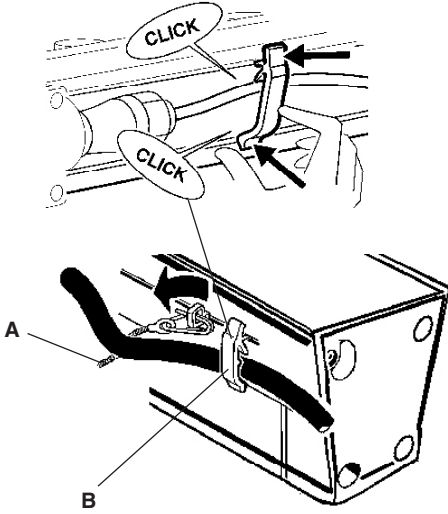

قبل تثبيت الوحدة على الدعامة الميكانيكية، الشبك كبلات التولاد «A» حسب ما هو مبين في الشكل. استخدم المشابك «B» لترتيب الكبلات الكهربائية بشكل تام خلف الوحدة.

I Prima di bloccare il modulo al supporto meccanico, agganciare i cavetti d'acciaio "A" come indicato in figura. Utilizzare le clips "B" per sistemare i cavi elettrici perfettamente dietro al modulo.

GB Before locking the module onto the mechanical support, hook on the steel cables "A" as indicated in the figure. Use the clips "B" to tidy up the electric cables behind the module.

E Antes de fijar el módulo al soporte mecánico, enganchar los cables de acero «A» según ilustrado en la figura. Utilizar las clips «B» para el perfecto alojamiento de los cables en el módulo.



ملاحظة: ملاحظة: أثناء تركيب نظام "LINEALUCE LED". يجب التقيد
بحرص بالنظم السائدة المتعلقة بالشبكة الكهربائية.

N.B.: DURANTE L'INSTALLAZIONE DEL SISTEMA RISPETTARE SCRUPolosAMENTE LE NORME IMPIANTISTICHE VIGENTI.

N.B.: WHEN INSTALLING THE SYSTEM, STRICTLY COMPLY WITH ALL REGULATIONS ON INSTALLATION IN FORCE.

N.B.: DURANTE LA INSTALACIÓN DEL SISTEMA RESPETAR E SCRUPolosAMENTE LAS NORMAS DE INSTALACIÓN VIGENTES.

تنبيه: لاستبدال الضوء LED اتصل بشركة iGuzzini . عر

I N.B.: Per la sostituzione del LED contattare l'azienda iGuzzini.

GB N.B.: For information on LED replacement please contact iGuzzini.

E NOTA: Para sustituir el LED llame a la empresa iGuzzini.



لا يمكن استخدام هذا المنتج في حالة وجود كسر في العدسات، ومن ثم
يجب الاتصال بالشركة المصنعة لاستبدال العدسات المكسورة.

I In caso di rottura delle lenti il prodotto non può essere utilizzato, contattare il costruttore per la sua sostituzione.

GB Should the lenses break, the product cannot be used. Contact the manufacturer for replacement.

E En caso de rotura de las lentes, el producto no puede utilizarse y se debe contactar con el fabricante para su sustitución.

⊕ art. BZH7 - BZH8 - BZH9

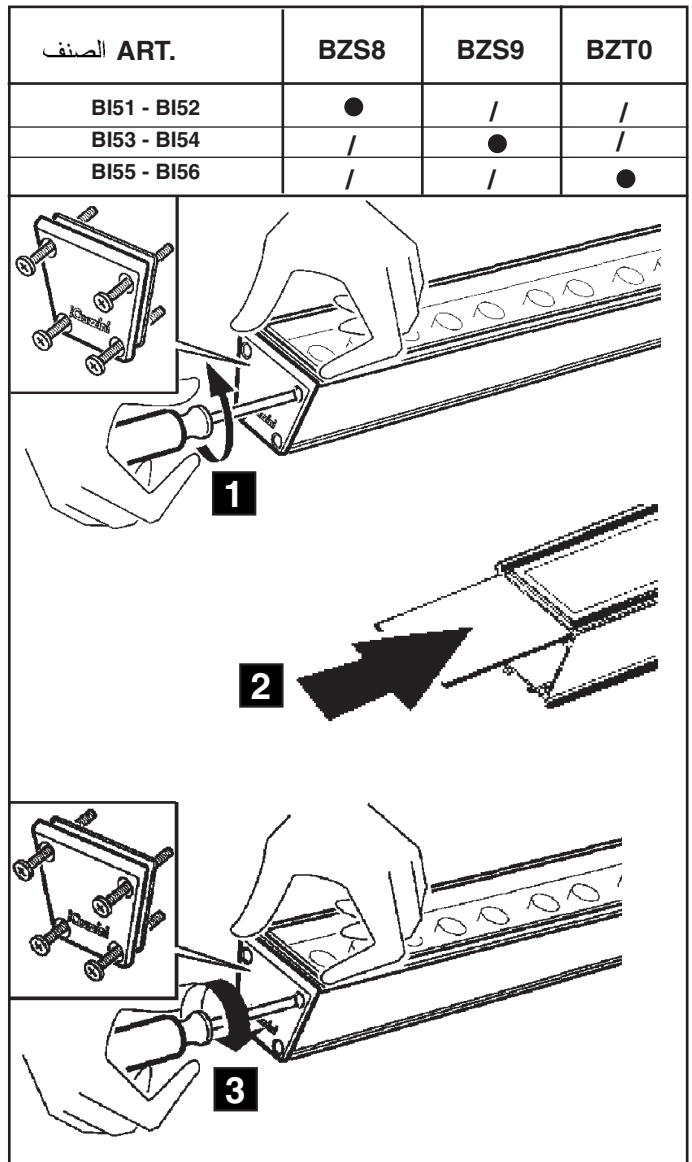
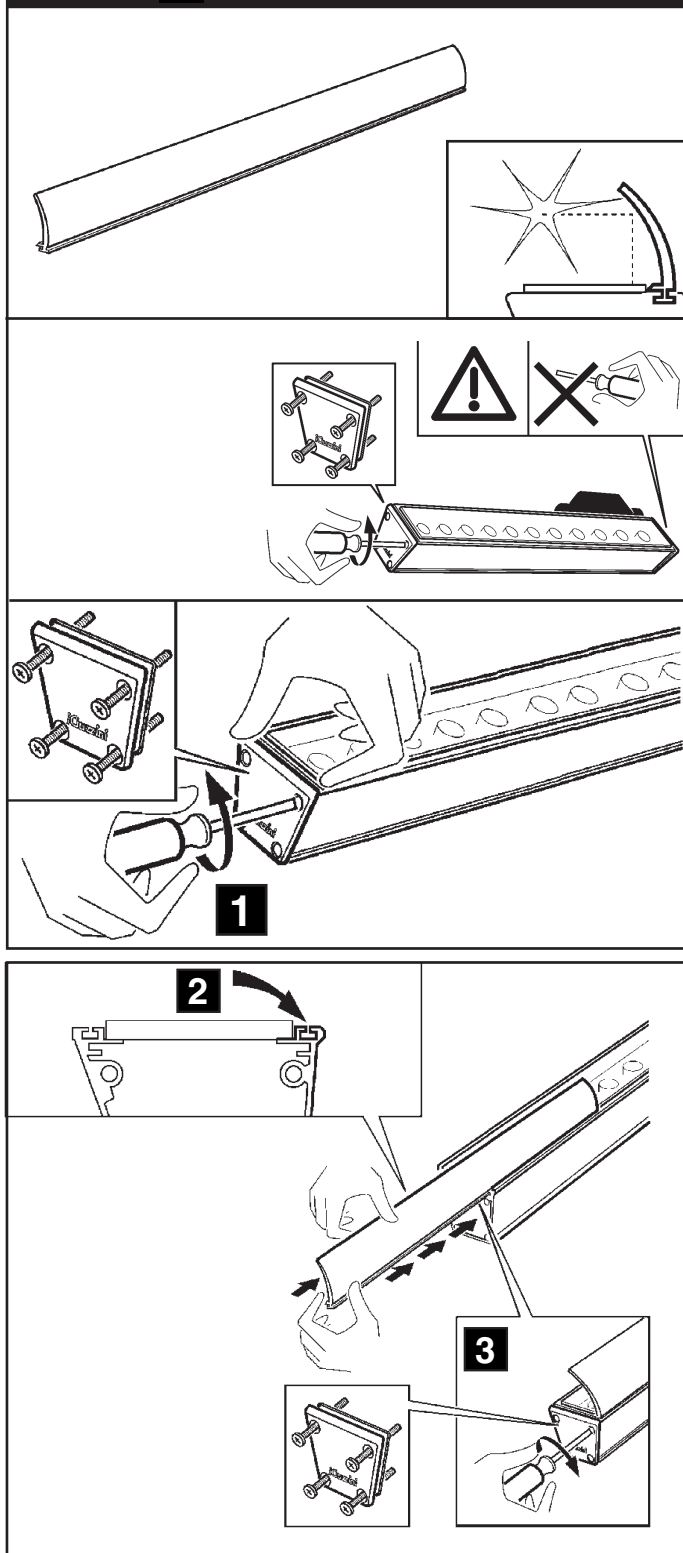

1.154.596.00
ISO6196/01

iGuzzini

I NON SOLLECITARE IL PRODOTTO A TORSIONE
GB DO NOT SUBMIT THE PRODUCT TO TWISTING
FR NE PAS SOUMETTRE LE PRODUIT À TORSION
DE LEUCHTE AUF KEINEN FALL IN LÄNGSRICHTUNG VERDREHEN!
NL BEWEEG HET PRODUCT NIET TERWIJL HET ONDERHEVIG IS AAN TORSIE
E NO FORZAR LA TORSIÓN DEL PRODUCTO
DK UDSÆ T IKKE PRODUKTET FOR VRIDNINGER
N IKKE UTSETT PRODUKTET FOR VRIDNING
S VRIDBELASTA INTE PRODUKTEN
RUS НЕ СКРУЧИВАТЬ ИЗДЕЛИЕ
CN 切勿使产品发生扭曲。

1.154.596.00
ISO6196/01

iGuzzini

I NON SOLLECITARE IL PRODOTTO A TORSIONE
GB DO NOT SUBMIT THE PRODUCT TO TWISTING
FR NE PAS SOUMETTRE LE PRODUIT À TORSION
DE LEUCHTE AUF KEINEN FALL IN LÄNGSRICHTUNG VERDREHEN!
NL BEWEEG HET PRODUCT NIET TERWIJL HET ONDERHEVIG IS AAN TORSIE
E NO FORZAR LA TORSIÓN DEL PRODUCTO
DK UDSÆ T IKKE PRODUKTET FOR VRIDNINGER
N IKKE UTSETT PRODUKTET FOR VRIDNING
S VRIDBELASTA INTE PRODUKTEN
RUS НЕ СКРУЧИВАТЬ ИЗДЕЛИЕ
CN 切勿使产品发生扭曲。

1.154.596.00
ISO6196/01

iGuzzini

I NON SOLLECITARE IL PRODOTTO A TORSIONE
GB DO NOT SUBMIT THE PRODUCT TO TWISTING
FR NE PAS SOUMETTRE LE PRODUIT À TORSION
DE LEUCHTE AUF KEINEN FALL IN LÄNGSRICHTUNG VERDREHEN!
NL BEWEEG HET PRODUCT NIET TERWIJL HET ONDERHEVIG IS AAN TORSIE
E NO FORZAR LA TORSIÓN DEL PRODUCTO
DK UDSÆ T IKKE PRODUKTET FOR VRIDNINGER
N IKKE UTSETT PRODUKTET FOR VRIDNING
S VRIDBELASTA INTE PRODUKTEN
RUS НЕ СКРУЧИВАТЬ ИЗДЕЛИЕ
CN 切勿使产品发生扭曲。

1.154.596.00
ISO6196/01

iGuzzini

I NON SOLLECITARE IL PRODOTTO A TORSIONE
GB DO NOT SUBMIT THE PRODUCT TO TWISTING
FR NE PAS SOUMETTRE LE PRODUIT À TORSION
DE LEUCHTE AUF KEINEN FALL IN LÄNGSRICHTUNG VERDREHEN!
NL BEWEEG HET PRODUCT NIET TERWIJL HET ONDERHEVIG IS AAN TORSIE
E NO FORZAR LA TORSIÓN DEL PRODUCTO
DK UDSÆ T IKKE PRODUKTET FOR VRIDNINGER
N IKKE UTSETT PRODUKTET FOR VRIDNING
S VRIDBELASTA INTE PRODUKTEN
RUS НЕ СКРУЧИВАТЬ ИЗДЕЛИЕ
CN 切勿使产品发生扭曲。

iGuzzini 2.519.534.02 IS07064/02	fattore di potenza power factor facteur de puissance Leistungsfaktor vermogensfactor factor de potencia effektfaktor effektfaktor effektfaktor фактор мощности 功率因数	corrente assorbita absorbed current courant absorbé Stromaufnahme stroomopname corriente absorbida absorberet strøm absorbert strøm tillförd ström поглощаемая мощность 电源电流 (A)
ART		
BG96	>0,9	0,040
BG97		
BG98		
BG99	>0,9	0,080
BH00		
BH01		
BH02	>0,9	0,110
BH03		
BH04		
BH05	>0,9	0,070
BH06		
BH07		
BH08	>0,9	0,130
BH09		
BI51		
BI52	>0,95	0,190
BH10		
BH11		
BI53	>0,95	0,09
BI54		
BH12		
BH13	>0,95	0,180
BI55		
BI56		
BI57 - BI58 - BI63 - BI64	>0,95	0,300
BI59 - BI60 - BI65 - BI66		
BI61 - BI62 - BI67 - BI68 - BN91 - BN88		
BI69 - BI72 - BP12 - BP14 - BM63 - BM66	>0,9	0,114
BI70 - BI73 - BP13 - BP15 - BM64 - BM67	>0,9	0,170
BI71 - BI74 - BM65 - BM68	>0,95	0,217
BM42 - BM45	>0,9	0,133
BM43 - BM46	>0,9	0,190
BM44 - BM47	>0,95	0,245
BN87 - BN90	-	0,119
BN89 - BN92	-	0,186
	-	0,16
	-	-
	-	-

iGuzzini 2.519.534.02 IS07064/02	fattore di potenza power factor facteur de puissance Leistungsfaktor vermogensfactor factor de potencia effektfaktor effektfaktor effektfaktor фактор мощности 功率因数	corrente assorbita absorbed current courant absorbé Stromaufnahme stroomopname corriente absorbida absorberet strøm absorbert strøm tillförd ström поглощаемая мощность 电源电流 (A)
ART		
BG96	>0,9	0,040
BG97		
BG98		
BG99	>0,9	0,080
BH00		
BH01		
BH02	>0,9	0,110
BH03		
BH04		
BH05	>0,9	0,130
BH06		
BH07		
BH08	>0,95	0,190
BH09		
BI51		
BI52	>0,95	0,09
BH10		
BH11		
BI53	>0,95	0,180
BI54		
BH12		
BH13	>0,95	0,300
BI55		
BI56		
BI57 - BI58 - BI63 - BI64	>0,95	0,114
BI59 - BI60 - BI65 - BI66		
BI61 - BI62 - BI67 - BI68 - BN91 - BN88		
BI69 - BI72 - BP12 - BP14 - BM63 - BM66	>0,9	0,170
BI70 - BI73 - BP13 - BP15 - BM64 - BM67	>0,9	0,217
BI71 - BI74 - BM65 - BM68	>0,95	0,133
BM42 - BM45	>0,9	0,190
BM43 - BM46	>0,9	0,245
BM44 - BM47	>0,95	0,119
BN87 - BN90	-	0,186
BN89 - BN92	-	0,16
	-	-
	-	-
	-	-

I PERIODO GIORNALIERO DI ACCENSIONE AMMESSO

GB ALLOWED DAILY OPERATION PERIOD

F DURÉE QUOTIDIENNE D'ALLUMAGE ADMISSIBLE

D ERLAUBTE TÄGLICHE EINSCHALTDAUER

NL DAGELIJKSE ONTSTEKINGSPERIODE TOEGESTAAN

E PERIODO DIARIO DE ENCENDIDO PERMITIDO

DK TILLADT TIDSRUM FOR DAGLIG TÆNDING

N TILLÄTT TENNINGSTID PR. DAG

S TILLÄTEN DAGLIG PERIOD SOM PRODUKTEN KAN VARA TÄND

RUS ЕЖЕДНЕВНАЯ ДОПУСТИМАЯ ПРОДОЛЖИТЕЛЬНОСТЬ РАБОТЫ

CN 允许的日常运营周期

iGuzzini

1.154.627.01
IS09175/01

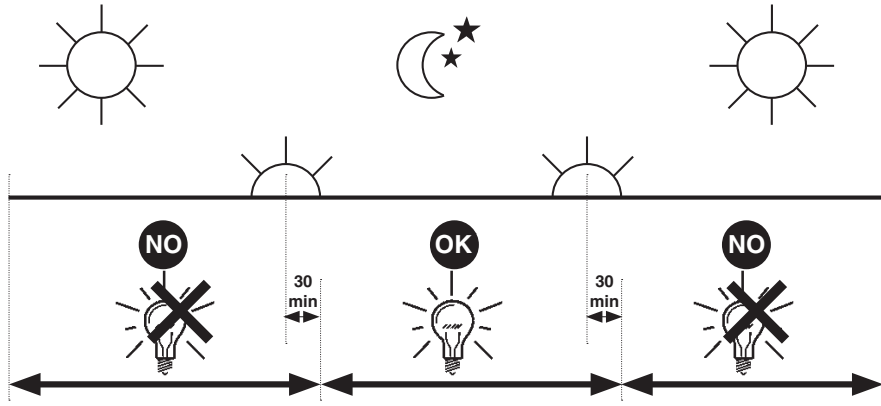

I PERIODO GIORNALIERO DI ACCENSIONE AMMESSO

GB ALLOWED DAILY OPERATION PERIOD

F DURÉE QUOTIDIENNE D'ALLUMAGE ADMISSIBLE

D ERLAUBTE TÄGLICHE EINSCHALTDAUER

NL DAGELIJKSE ONTSTEKINGSPERIODE TOEGESTAAN

E PERIODO DIARIO DE ENCENDIDO PERMITIDO

DK TILLADT TIDSRUM FOR DAGLIG TÆNDING

N TILLÄTT TENNINGSTID PR. DAG

S TILLÄTEN DAGLIG PERIOD SOM PRODUKTEN KAN VARA TÄND

RUS ЕЖЕДНЕВНАЯ ДОПУСТИМАЯ ПРОДОЛЖИТЕЛЬНОСТЬ РАБОТЫ

CN 允许的日常运营周期

iGuzzini

1.154.627.01
IS09175/01

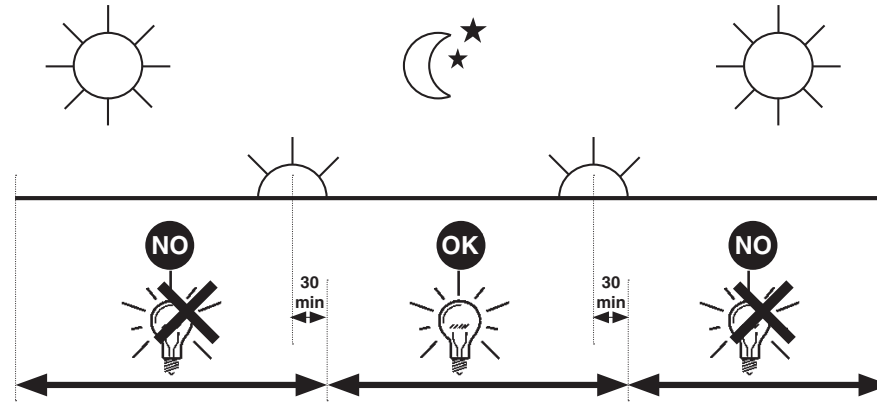

I PERIODO GIORNALIERO DI ACCENSIONE AMMESSO

GB ALLOWED DAILY OPERATION PERIOD

F DURÉE QUOTIDIENNE D'ALLUMAGE ADMISSIBLE

D ERLAUBTE TÄGLICHE EINSCHALTDAUER

NL DAGELIJKSE ONTSTEKINGSPERIODE TOEGESTAAN

E PERIODO DIARIO DE ENCENDIDO PERMITIDO

DK TILLADT TIDSRUM FOR DAGLIG TÆNDING

N TILLÄTT TENNINGSTID PR. DAG

S TILLÄTEN DAGLIG PERIOD SOM PRODUKTEN KAN VARA TÄND

RUS ЕЖЕДНЕВНАЯ ДОПУСТИМАЯ ПРОДОЛЖИТЕЛЬНОСТЬ РАБОТЫ

CN 允许的日常运营周期

iGuzzini

1.154.627.01
IS09175/01

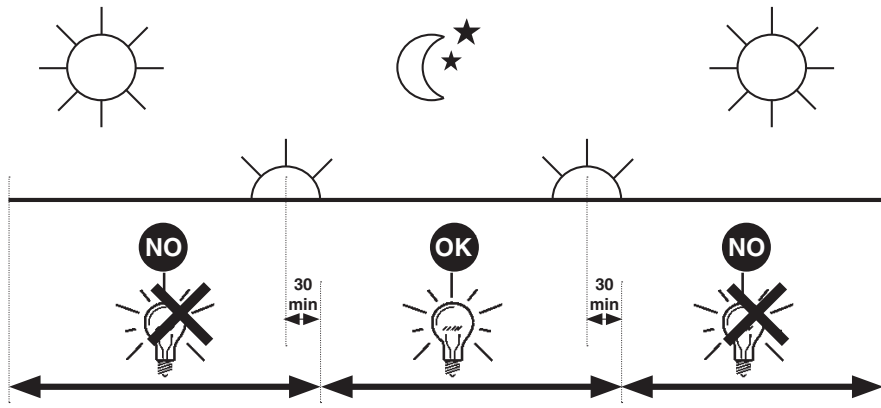

I PERIODO GIORNALIERO DI ACCENSIONE AMMESSO

GB ALLOWED DAILY OPERATION PERIOD

F DURÉE QUOTIDIENNE D'ALLUMAGE ADMISSIBLE

D ERLAUBTE TÄGLICHE EINSCHALTDAUER

NL DAGELIJKSE ONTSTEKINGSPERIODE TOEGESTAAN

E PERIODO DIARIO DE ENCENDIDO PERMITIDO

DK TILLADT TIDSRUM FOR DAGLIG TÆNDING

N TILLÄTT TENNINGSTID PR. DAG

S TILLÄTEN DAGLIG PERIOD SOM PRODUKTEN KAN VARA TÄND

RUS ЕЖЕДНЕВНАЯ ДОПУСТИМАЯ ПРОДОЛЖИТЕЛЬНОСТЬ РАБОТЫ

CN 允许的日常运营周期

iGuzzini

1.154.627.01
IS09175/01

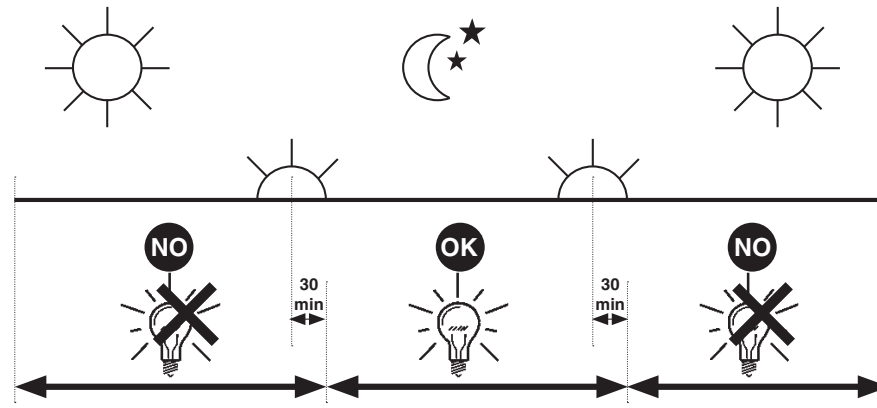

عر

لا تعرض المنتج للالتواء

- I NON SOLLECITARE IL PRODOTTO A TORSIONE
- GB DO NOT SUBMIT THE PRODUCT TO TWISTING
- E NO FORZAR LA TORSIÓN DEL PRODUCTO

عر

لا تعرض المنتج للالتواء

- I NON SOLLECITARE IL PRODOTTO A TORSIONE
- GB DO NOT SUBMIT THE PRODUCT TO TWISTING
- E NO FORZAR LA TORSIÓN DEL PRODUCTO

عر

لا تعرض المنتج للالتواء

- I NON SOLLECITARE IL PRODOTTO A TORSIONE
- GB DO NOT SUBMIT THE PRODUCT TO TWISTING
- E NO FORZAR LA TORSIÓN DEL PRODUCTO

عر

لا تعرض المنتج للالتواء

- I NON SOLLECITARE IL PRODOTTO A TORSIONE
- GB DO NOT SUBMIT THE PRODUCT TO TWISTING
- E NO FORZAR LA TORSIÓN DEL PRODUCTO

عر

لا تعرض المنتج للالتواء

- I NON SOLLECITARE IL PRODOTTO A TORSIONE
- GB DO NOT SUBMIT THE PRODUCT TO TWISTING
- E NO FORZAR LA TORSIÓN DEL PRODUCTO

عر

منتج للالتواء

- I NON SOLLECITARE IL PRODOTTO A TORSIONE
- GB DO NOT SUBMIT THE PRODUCT TO TWISTING
- E NO FORZAR LA TORSIÓN DEL PRODUCTO

عر

منتج للالتواء

- I NON SOLLECITARE IL PRODOTTO A TORSIONE
- GB DO NOT SUBMIT THE PRODUCT TO TWISTING
- E NO FORZAR LA TORSIÓN DEL PRODUCTO

عر

منتج للالتواء

- I NON SOLLECITARE IL PRODOTTO A TORSIONE
- GB DO NOT SUBMIT THE PRODUCT TO TWISTING
- E NO FORZAR LA TORSIÓN DEL PRODUCTO

عر

منتج للالتواء

- I NON SOLLECITARE IL PRODOTTO A TORSIONE
- GB DO NOT SUBMIT THE PRODUCT TO TWISTING
- E NO FORZAR LA TORSIÓN DEL PRODUCTO

عر

منتج للالتواء

- I NON SOLLECITARE IL PRODOTTO A TORSIONE
- GB DO NOT SUBMIT THE PRODUCT TO TWISTING
- E NO FORZAR LA TORSIÓN DEL PRODUCTO

iGuzzini

2.509.386.00
ISO9176/01

الفترة الزمنية اليومية للتشغيل المسموح بها

- I PERIODO GIORNALIERO DI ACCENSIONE AMMESSO
- GB ALLOWED DAILY OPERATION PERIOD
- E PERIODO DIARIO DE ENCENDIDO PERMITIDO

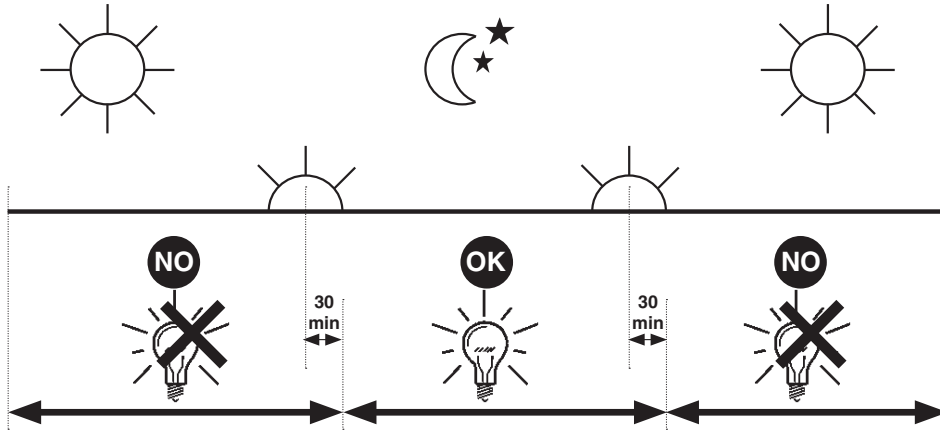

iGuzzini

2.509.386.00
ISO9176/01

الفترة الزمنية اليومية للتشغيل المسموح بها

- I PERIODO GIORNALIERO DI ACCENSIONE AMMESSO
- GB ALLOWED DAILY OPERATION PERIOD
- E PERIODO DIARIO DE ENCENDIDO PERMITIDO



iGuzzini

2.509.386.00
ISO9176/01

الفترة الزمنية اليومية للتشغيل المسموح بها

- I PERIODO GIORNALIERO DI ACCENSIONE AMMESSO
- GB ALLOWED DAILY OPERATION PERIOD
- E PERIODO DIARIO DE ENCENDIDO PERMITIDO

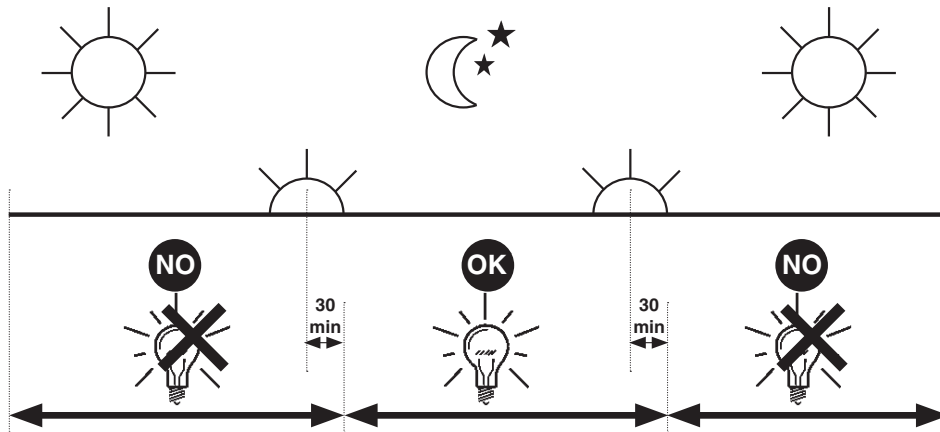

iGuzzini

2.509.386.00
ISO9176/01

الفترة الزمنية اليومية للتشغيل المسموح بها

- I PERIODO GIORNALIERO DI ACCENSIONE AMMESSO
- GB ALLOWED DAILY OPERATION PERIOD
- E PERIODO DIARIO DE ENCENDIDO PERMITIDO



- I Istruzioni per le operazioni di servizio per l'apparecchio di illuminazione**
GB Instructions on luminaire service operations
F Instructions pour les opérations de service du luminaire
D Wartungsanleitung für die Leuchte
NL Instructies voor de onderhoudsoperaties op de verlichtingsarmatuur
E Instrucciones para las operaciones de servicio del aparato de alumbrado
DK Anvisninger i serviceindgreb på belysningsarmatur
N Anvisninger for betjening av lysapparatet
S Instruktioner för användning av belysningsanordningen
RUS Инструкции по эксплуатации осветительного прибора
CN 照明装置检修操作说明

Sostituire la lampada parzialmente esausta
 Replace the partly exhausted lamp
 Remplacer la lampe partiellement épuisée
 Die teilweise erschöpfte Lampe austauschen
 Vervang de gedeeltelijk lege lamp
 Sustituir la lámpara parzialmente agotada
 Udskift den delvist udtjente pære
 Skifte ut den delvis utbrente lyspæren
 Byt ut den delvis förbrukade lampan
 Замена частично отработанной лампочки
 更换部分老化的灯泡



Spegnimento
 Switch it off
 Extinction
 Ausschaltung
 Uitschakeling
 Apagado
 Slukning
 Slukking
 Släckning
 Выключение
 关灯

Interrompere l'alimentazione dell'apparecchio
 Cut the power supply to the luminaire
 Couper l'alimentation du luminaire
 Stromversorgung der Leuchte unterbrechen
 Onderbreek de voeding van het apparaat
 Interrumpir la alimentación del aparato
 Afbryd armaturets strømforsyning
 Avbryte strømtilførselen til apparatet
 Koppla från anordningens strömförsörjning
 Отключить электропитание прибора
 中断装置供电



Aprire l'apparecchio
 Open the fixture
 Ouvrir le luminaire
 Das Gerät öffnen
 Open het apparaat
 Abrir el aparato
 Åbn armaturet
 Åpne apparatet
 Öppna anordningen
 Раскрыть прибор
 打开装置



Rimuovere la lampada esausta
 Remove the exhausted lamp
 Retirer la lampe épuisée
 Die alte Lampe entnehmen
 Verwijder de lege lamp
 Quitar la lámpara agotada
 Tag den udtjente pære ud
 Fjerne den utbrente lyspæren
 Ta bort den förbrukade lampan
 Вынуть старую лампочку
 取出老化的灯泡

Portarla in un centro di riciclaggio
 Carry it to a recycling centre
 La porter dans une déchetterie pour son recyclage
 Ordnungsgemäß entsorgen
 Breng de lamp naar een recyclingcentrum
 Llevarla a un centro de reciclaje
 Aflever den på en genbrugsstation
 Lever den til en miljøstasjon
 Lämna in den till en återvinningsanläggning
 Сдать ее в пункт приема утильсырья
 将其送往回收中心

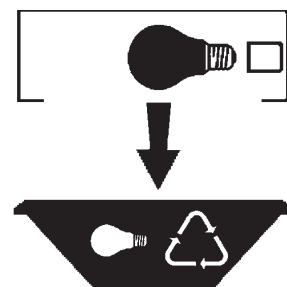

Inserire la nuova lampada
 Introduce the new lamp
 Installer la lampe neuve
 Die neue Lampe einsetzen
 Doe de nieuwe lamp op zijn plek
 Montar la nueva lámpara
 Sæt den nye pære i
 Sette i den nye pæren
 Sätt i den nya lampan
 Вставить новую лампочку
 装入新灯泡

Inserire la nuova lampada nel portalampana
 Fit the new lamp into the socket
 Installer la nouvelle lampe dans le support de lampe
 Die neue Lampe in den Sockel einsetzen
 Doe de nieuwe lamp in de lamphouder
 Montar la nueva lámpara en el portalampana
 Sæt den nye pære i fatningen
 Sette den nye pæren inn i lampeholderen
 Sätt i den nya lampan i lamphållaren
 Вставить новую лампочку в патрон
 将新灯泡插入灯泡架中



Riposizionare ottica
 Re-place the optic
 Remettre l'optique à sa place
 Die Optik wieder einsetzen
 Doe de optiek weer op zijn plaats
 Volver a montar la óptica
 Sæt den optiske enhed på plads
 Innstille linsen
 Flytta om optiken
 Отрегулировать линзы
 重新定位光头



Effettuare prova di funzionamento
 Perform operative test
 Procéder à un essai de fonctionnement
 Eine Funktionsprüfung durchführen
 Controleer de correcte werking
 Hacer una prueba de funcionamiento
 Afprøv funktionen
 Prøve om den fungerer
 Utför funktionstest
 Выполнить проверку исправности работы
 执行功能测试



I Istruzioni per la pulizia dell'apparecchio di illuminazione
GB Instructions on luminaire cleaning operations
F Instructions pour le nettoyage du luminaire
D Anweisungen zur Reinigung der Leuchte
NL Instructies voor de reiniging van de verlichtingsarmatuur
E Instrucciones para limpiar el aparato de alumbrado
DK Anvisninger i rengøring af belysningsarmaturet
N Anvisninger for rengjøring av lysapparatet
S Instruktioner för rengöring av belysningsanordningen
RUS Инструкции по чистке осветительного прибора
CN 照明装置清洁说明

Pulire l'apparecchio
Clean the fixture
Nettoyer le luminaire
Das Gerät reinigen
Reinig het apparaat
Limpiar el aparato
Rengør armaturet
Rengjøre apparatet
Rengör anordningen
Чистка прибора
清洁装置



Spegnimento
Switch it off
Extinction
Ausschaltung
Uitschakeling
Apagado
Slukning
Slukking
Släckning
Выключение
关灯

Interrompere l'alimentazione dell'apparecchio
Cut the power supply to the luminaire
Couper l'alimentation du luminaire
Stromversorgung der Leuchte unterbrechen
Onderbreek de voeding van het apparaat
Interrumpir la alimentación del aparato
Afbryd armaturets strømforstyrning
Avbryt strømtilførselen til apparatet
Koppla från anordningens strömförsörjning
Отключить электропитание прибора
中断装置供电



Spolverare l'ottica esterna
Remove dust from the external optic
Dépoussiérer l'optique extérieure
Die externe Optik abstauben
Stof de externe optiek af
Quitar el polvo de la óptica exterior
Tør støvet af den udvendige optiske enhed
Fjerne støv fra den eksterne lysenheden
Damma av den yttre optiken
Вытереть пыль с внешней стороны линз
为外侧光头掸尘



Lavare l'ottica esterna
Wash the external optic
Laver l'optique extérieure
Die externe Optik waschen
Was de externe optiek
Lavar la óptica exterior
Vask den udvendige optiske enhed
Vaske den eksterne lysenheden
Rengör den yttre optiken
Вымыть линзы с внешней стороны
清洁外光头



Rimuovere l'ottica
Remove the optic
Retirer l'optique
Die Optik abnehmen
Verwijder de optiek
Quitar la óptica
Tag den optiske enhed af
Fjerne lysenheden
Ta bort optiken
Снять линзы
取下光头

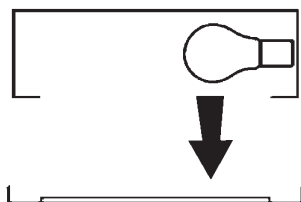

Pulire la parte interna dell'apparecchio di illuminazione
Clean the inside of the fixture
Nettoyer l'intérieur du luminaire
Die Innenseite der Leuchte reinigen
Reinig de binnenzijde van de verlichtingsarmatuur
Limpiar el interior del aparato de alumbrado
Rengør belysningsarmaturets indvendige dele
Rengjøre lysapparatet innvendig
Rengör belysningsanordningen invändigt
Протереть осветительный прибор изнутри
清洁照明装置内部



Riposizionare ottica
Re-place the optic
Remettre l'optique à sa place
Die Optik wieder einsetzen
Doe de optiek weer op zijn plaats
Volver a montar la óptica
Sæt den optiske enhed på plads
Innstille linsen
Flytta om optiken
Отрегулировать линзы
重新定位光头

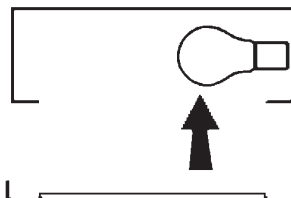

Effettuare prova di funzionamento
Perform operative test
Procéder à un essai de fonctionnement
Eine Funktionsprüfung durchführen
Controleer de correcte werking
Hacer una prueba de funcionamiento
Afprov funktionen
Prøve om den fungerer
Utför funktionstest
Выполнить проверку исправности работы
执行功能测试

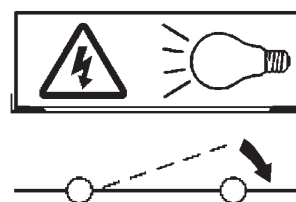

- I** Istruzioni per il fine vita e lo smaltimento dei componenti
GB Instructions on end-of-life and component disposal
F Instructions pour la gestion des composants en fin de vie et leur mise au rebut
D Anweisungen zur Entsorgung der Leuchtenkomponenten
NL Instructies voor het verwijderen van de armatuur en het recyclen van de onderdelen
E Instrucciones para el final de vida y la eliminación los componentes
DK Anvisninger i udtjent armatur og bortskaffelse af komponenter
N Anvisninger for endt levetid og avfallsbehandling av delene
S Instruktioner vid bortskaffning och kassering av komponenter
RUS Инструкции по утилизации прибора и его комплектующих по окончании его срока службы
CN 寿命期结束与零件废弃处置说明

<p>Spegnimento Switch it off Extinction Ausschaltung Uitschakeling Apagado Slukning Slukking Släckning Выключение 关灯</p> <p>Interrompere l'alimentazione dell'apparecchio Cut the power supply to the luminaire Couper l'alimentation du luminaire Stromversorgung der Leuchte unterbrechen Onderbreek de voeding van het apparaat Interrompirla alimentación del aparato Afbryd armaturets strømforsyning Avbryt strømtilførselen til apparatet Koppla från anordningens strömförsörjning Отключить электропитание прибора 中断装置供电</p> 	<p>Rimuovere la/e lampada/e per la dismissione Remove the lamp(s) for decommissioning Retirer la(les) lampe(s) pour sa(leur) mise au rebut Die Lampe/n ordnungsgemäß entsorgen Verwijder de lamp(en) voor het recyclen Quitar la(s) lámpara(s) para el desecho Tag pæren/pærerne ud til bortskaffelse Fjerne lampen/-e som skal kastes Ta bort lampan/-orna för bortskaffningen Вынуть лампочку/и для утилизации прибора 取出需要丢弃的灯泡</p> 	<p>Rimuovere la batteria per la dismissione Remove the battery for decommissioning Retirer la batterie pour sa mise au rebut Die Batterie ordnungsgemäß entsorgen Verwijder de batterij voor het recyclen Quitar la batería para el desecho Tag batteriet ud til bortskaffelse Fjerne batteriet som skal kastes Ta bort batteriet för bortskaffningen Вынуть батарейку для утилизации прибора 取出需要丢弃的电池</p> 	<p>Rimuovere l'apparecchio per la dismissione Remove the fixture for decommissioning Enlever le luminaire pour sa mise au rebut Das Gerät ordnungsgemäß entsorgen Verwijder het apparaat voor het recyclen Quitar el aparato para el desecho Tag armaturet ud til bortskaffelse Fjerne apparatet som skal kastes Ta bort anordningen för bortskaffningen Снять прибор для утилизации 取出需要丢弃的装置</p> 
---	--	--	--

<p>Inviare i materiali ad un centro di raccolta RAEE Send the materials to a WEEE collection centre Envoyer les matériaux dans une déchetterie DEEE Die Materialien in einem WEEE-Zentrum entsorgen Zend de materialen naar een recyclingscentrum voor de AEEA Enviar los materiales a un centro de recogida RAEE Afløver materialerne på et indsamlingscenter for elektronisk udstyr Sende materialene til en miljøstasjon for resirkulering av EE-avfall Skicka materialet till en RAEE uppsamlingscentral Сдать материалы в пункт приема утильсырья 将材料送往电气和电子垃圾回收中心</p> 			
--	--	--	--