

iN90 LED

I ATTENZIONE:

LA SICUREZZA DELL'APPARECCHIO E' GARANTITA SOLO CON L'USO APPROPRIATO DELLE SEGUENTI ISTRUZIONI; PERTANTO E' NECESSARIO CONSERVARLE.

GB WARNING:

THE SAFETY OF THIS FIXTURE IS GUARANTEED ONLY IF YOU COMPLY WITH THESE INSTRUCTIONS; REMEMBER TO CONSERVE IN A SAFE PLACE.

F ATTENTION:

LA SECURITE DE L'APPAREIL N'EST GARANTIE QU'EN CAS D'UTILISATION CORRECTE DES INSTRUCTIONS SUIVANTES; IL FAUT PAR CONSEQUENT LES CONSERVER.

D ACHTUNG:

DIE SICHERHEIT DES GERÄTES WIRD NUR DURCH SACHGEMÄSSE BEFOLGUNG NACHSTEHENDER ANWEISUNGEN GEWÄHRLEISTET; IHRE AUFBEWAHRUNG IST DESHALB SEHR WICHTIG.

NL OPGELET:

DE VEILIGHEID VAN DI ATOESTEL IS SLECHTS DAN GEGARANDEERD ALS INDIEN DE VOLGENDE INSTRUCTIES STRIKT WORDEN TOEGEPAST: DAAROM MOET MEN ZE OOK BEWAREN.

E ATENCION:

LA SEGURIDAD DEL APARATO SE GARANTIZA SOLO CUMPLIENDO CUIDADOSAMENTE LAS SIGUIENTES INSTRUCCIONES; POR ELLO, ES NECESARIO CONSERVARLAS.

DK BEMÆRK:

SIKKERHEDEN VED BRUG AF ARMATURET KAN KUN GARANTERES, HVIS DISSE ANVISNINGER FØLGES; SØRG DERFOR FOR AT GEMME DEM.

N ADVARSEL:

SIKKERHETEN TIL DETTE APPARATET GARANTERES KUN HVIS DU OVERHOLDER DISSE INSTRUKSJONENE; HUSK Å OPPBEVARE DEM PÅ ET TRYGT STED.

S OBSERVERA!

UTRUSTNINGENS SÄKERHET KAN ENDAST GARANTERAS OM DESSA ANVISNINGAR RESPEKTERAS I DETALJ. SPARA DÄRFÖR DESSA ANVISNINGAR FÖR FRAMTIDA KONSULTATION.

RUS ВНИМАНИЕ:

МЫ ГАРАНТИРУЕМ БЕЗОПАСНУЮ ЭКСПЛУАТАЦИЮ ИЗДЕЛИЯ ТОЛЬКО ПРИ СОБЛЮДЕНИИ СПЕДУЮЩИХ ИНСТРУКЦИЙ; С ЭТОЙ ЦЕЛЬЮ НЕОБХОДИМО СОХРАНИТЬ ДАННУЮ БРОШЮРУ.

CN 警告

为确保该装置安全，请遵守操作指示；并于安全场所放置。

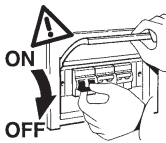

N.B.: DURANTE L'INSTALLAZIONE DEL SISTEMA "iN 90 LED" RISPETTARE SCRUPOLOSAMENTE LE NORME IMPIANTISTICHE NAZIONALI VIGENTI.

N.B.: WHEN INSTALLING THE "iN 90 LED" SYSTEM, MAKE SURE ALL CURRENT NATIONAL REGULATIONS RELATING TO INSTALLATION ARE OBSERVED.

N.B.: LORS DE L'INSTALLATION DU SYSTÈME "iN 90 LED" VEUILLEZ RESPECTER RIGOREUSEMENT LES NORMES EN VIGUEUR EN LA MATIÈRE DANS LE PAYS.

N.B.: BEACHTEN SIE BEI DER INSTALLATION DES SYSTEMS "iN 90 LED" UNBEDINGT DIE IM LAND GELTENDEN ANLAGETECHNISCHEN VORSCHRIFTEN.

N.B.: BIJ HET INSTALLEREN VAN HET "iN 90 LED" SYSTEEM MOET U DE GELDENDE NATIONALE INSTALLATIENORMEN STRIKT NALEVEN.

NOTA: DURANTE LA INSTALACIÓN DEL SISTEMA "iN 90 LED" RESPETAR ESCRUPULOSAMENTE LAS NORMAS NACIONALES DE INSTALACIÓN EN VIGOR.

N.B.: UNDER INSTALLATION AF "iN 90 LED" SYSTEMET SKAL MAN NØJE OVERHOLDE DE GÆLDENDE REGLER FOR DISSE ANLÆG.

N.B.: UNDER INSTALLASJON AV SYSTEMET "iN 90 LED" MÅ DE NASJONALE ANLEGGSFORSKRIFTENE OVERHOLDES NØYE.

OBS! UNDER INSTALLATIONEN AV SYSTEMET "iN 90 LED" SKA GÄLLANDE NATIONELLA INSTALLATIONSFÖRESKRIFTER RESPEKTERAS I DETALJ.

ПРИМЕЧАНИЕ: В ПРОЦЕССЕ МОНТАЖА СИСТЕМЫ "iN 90 LED" СТРОГО СОБЛЮДАЙТЕ НАЦИОНАЛЬНЫЕ ДЕЙСТВУЮЩИЕ НОРМАТИВЫ ПО ЭЛЕКТРОПРОВОДКЕ.

重要：安装 "iN 90 LED" 系统时请始终参照标准系统

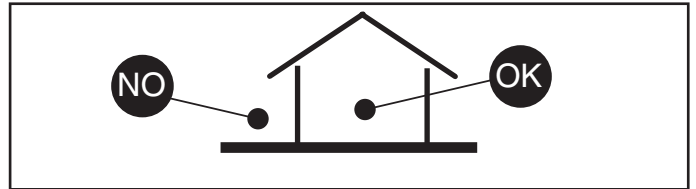

INSTALLAZIONE SUL CONTROSOFFITTO
INSTALLATION ON CEILING
INSTALLATION AU FAUX-PLAFOND
INSTALLATION AN DER HÄNGEDECKE
HET INSTALLEREN IN HET VERLAAGDE PLAFOND
INSTALACION SOBRE FALSO TECHO
INSTALLATION PÅ FORSÆNKET LOFT
MONTERING I TAKET
INSTALLATION I UNDERTAK
МОНТАЖ В ФАЛЬШ-ПОТОЛКЕ
吸顶式安装天花板上的安装

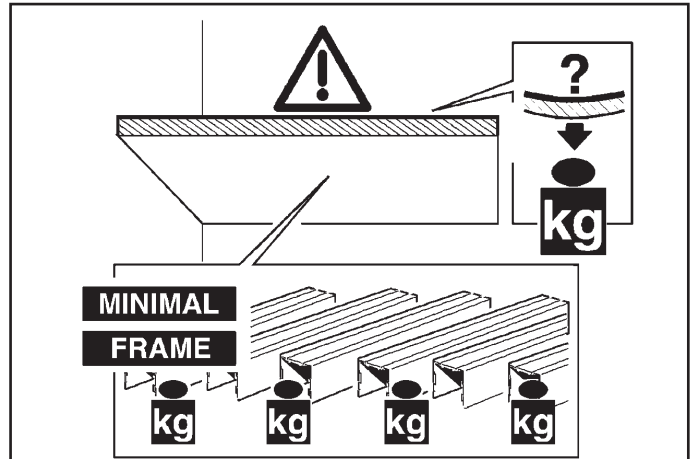

I N.B.: E' responsabilità dell'utente verificare la resistenza del controsoffitto, in funzione del peso degli apparecchi installati.

GB N.B.: It is the user's responsibility to check the strength of the false ceiling with respect to the weight of the fixtures installed.

F N.B.: Il appartient à l'utilisateur de vérifier la résistance du faux plafond en fonction du poids des appareils installés.

D N.B.: Es obliegt dem Verbraucher sicherzustellen, daß die Deckenverkleidung das Gewicht der Einbauleuchte aufnehmen kann.

NL N.B.: Het is de verantwoordelijkheid van de koper zich ervan te verzekeren dat het verlaagde plafond stevig genoeg is voor het dragen van het gewicht van de geïnstalleerde apparaten.

E NOTA: Corresponde al usuario efectuar las pruebas en el falso techo, en función del peso de los aparatos instalados.

DK N.B.: Det er brugerens ansvar, at kontrollere loftets modstanddygtighed, ud fra de installerede apparaters vægt.

N N.B.: Det er brukerens ansvar å kontrollere himlingens/takets motstandskraft, på grunnlag av de installerte apparatens vekt.

S OBS! Det är användarens ansvar att kontrollera takets hållfasthet i förhållande till vikten på installerad utrustning.

RUS ПРИМЕЧАНИЕ: Пользователь должен проверить прочность фальш-потолка в соответствии с весом устанавливаемых в него приборов.

CN 注意：用户须根据安装装置的重量 检查天花板的强度。

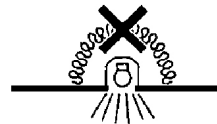

I N.B.: Apparecchi non idonei ad essere coperti di materiale termicamente isolante

GB N.B.: Fixtures not suitable to be covered in thermally-insulating material.

F N.B.: Appareils ne pouvant pas être couverts de matériau d'isolation thermique

D N.B.: Geräte nicht geeignet, um mit wärmeisolierendem Material abgedeckt zu werden

NL N.B.: Deze apparaten zijn niet geschikt om te worden bedekt met thermisch isolerend materiaal

E NOTA: Aparatos no aptos para ser cubiertos de material térmicamente aislante

DK N.B.: Armaturerne må ikke dækkes af varmeisolerende materiale.

N N.B.: Apparaten passer ikke til å dekkes av termoisolerende materialer.

S OBS! Utrustningen får inte täckas över med värmeisolerande material

RUS Внимание: Приборы непригодны для покрытия термоизоляционным материалом.

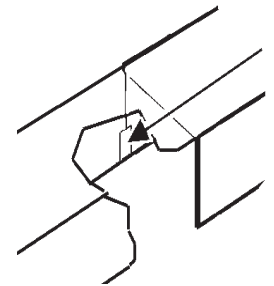
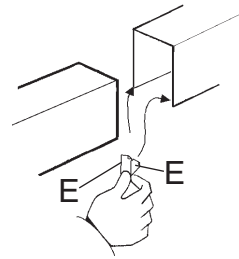
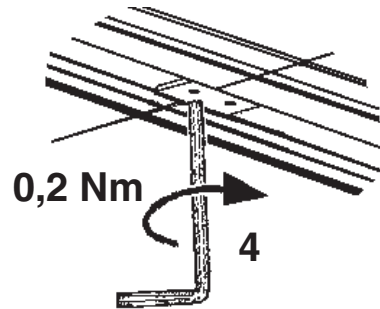
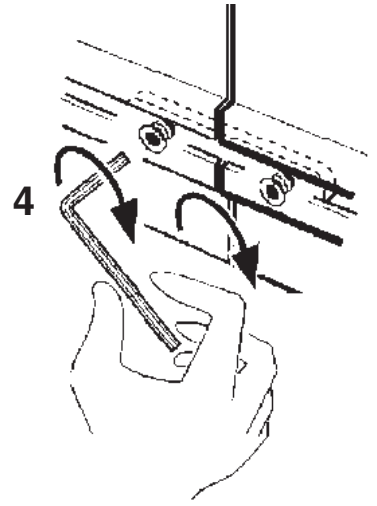
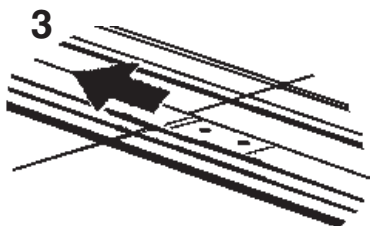
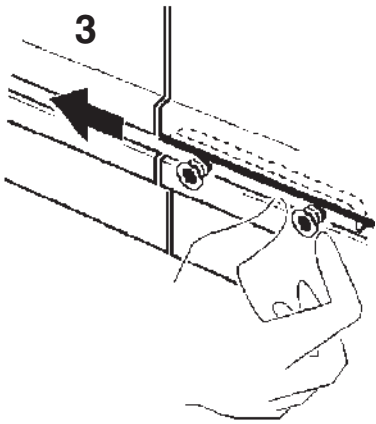
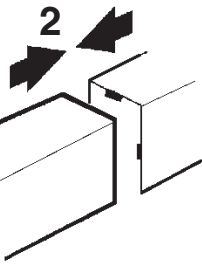
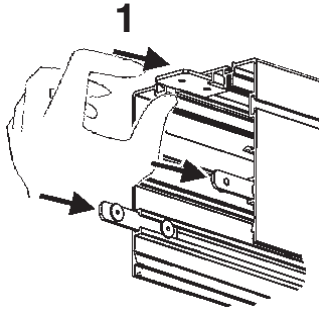
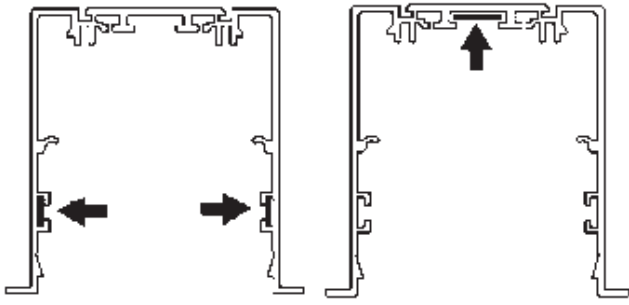

CN 灯具不适宜用隔热材料加以覆盖。



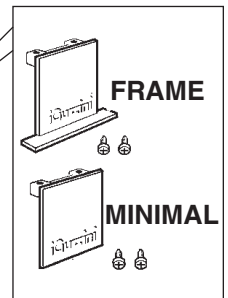
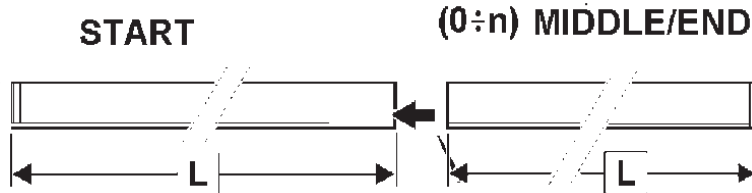
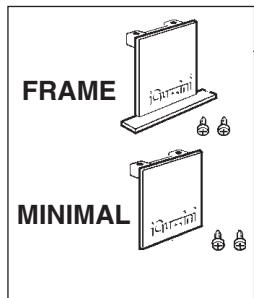

- I Applicare l'etichetta "E" come mostrato in figura.
- GB Apply label "E" as shown in the figure.
- F Appliquez l'étiquette "E" comme illustré (voir figure).
- D Bringen Sie das Etikett "E" wie in der Abbildung dargestellt an.
- NL Bevestig het etiket "E" zoals aangegeven in de figuur.
- E Aplicar la etiqueta "E" según ilustrado en la figura.
- DK Sæt mærkatet "E" på, som vist i figuren.
- N Innrett merke "E" slik som vist på figuren.
- S Applicera etiketten "E" enligt figuren.
- RUS Нанесите этикетку «Е», как показано на схеме.
- CN 按表中所示贴上标签“E”。

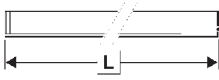
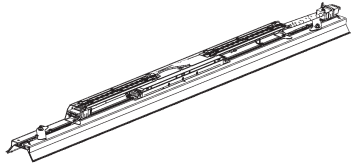

UP/ DOWN

TYPE	L (mm)	 ART.	START	MIDDLE/END	
 GENERAL LIGHTING LOW CONTRAST	1208	Q368	●		Q416 - Q417 - Q418 - Q419
	2397	Q369	●		2xQ416 - 2xQ417 - 2xQ418 - 2xQ419
	3596	Q370	●		3xQ416 - 3xQ417 - 3xQ418 - 3xQ419
	3596	Q371		●	3xQ416 - 3xQ417 - 3xQ418 - 3xQ419
 UGR <19°	1208	Q432	●		Q456 - Q457 - Q458 - Q459
	2397	Q433	●		2xQ456 - 2xQ457 - 2xQ458 - 2xQ459
	3596	Q434	●		3xQ456 - 3xQ457 - 3xQ458 - 3xQ459
	3596	Q435		●	3xQ456 - 3xQ457 - 3xQ458 - 3xQ459

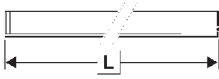
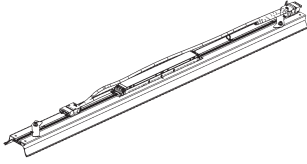
DOWN

TYPE	L (mm)	 ART.	START	MIDDLE/END	
 GENERAL LIGHTING LOW CONTRAST	612	Q356 - Q362	●		Q404 - Q407 - Q410 - Q413
	898	Q360 - Q366		●	Q405 - Q408 - Q411 - Q414
	1208	Q357 - Q363	●		Q406 - Q409 - Q412 - Q415
	2397	Q358 - Q364	●		2xQ406 - 2xQ409 - 2xQ412 - 2xQ415
	3596	Q359 - Q365	●		3xQ406 - 3xQ409 - 3xQ412 - 3xQ415
	3596	Q361 - Q367		●	3xQ406 - 3xQ409 - 3xQ412 - 3xQ415
 UGR <19°	612	Q420 - Q426	●		Q444 - Q447 - Q450 - Q453
	898	Q424 - Q430		●	Q445 - Q448 - Q451 - Q454
	1208	Q421 - Q427	●		Q446 - Q449 - Q452 - Q455
	2397	Q422 - Q428	●		2xQ446 - 2xQ449 - 2xQ452 - 2xQ455
	3596	Q423 - Q429	●		3xQ446 - 3xQ449 - 3xQ452 - 3xQ455
	3596	Q425 - Q431		●	3xQ446 - 3xQ449 - 3xQ452 - 3xQ455

ALIMENTAZIONE
 POWER SUPPLY
 ALIMENTATION
 EINSPEISUNG
 STROOMVERZORGING
 ALIMENTACION
 STRØMFORSYNING
 STRØMFORSYNING
 ELFÖRSÖRJNING
 ЭЛЕКТРОПИТАНИЕ
 电源



START

(0:n) MIDDLE/END ...

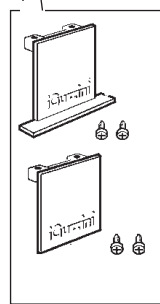
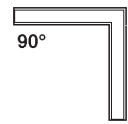

(0:n) MIDDLE/END ...

START

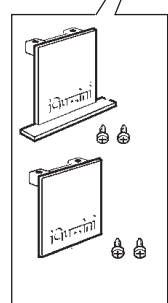

ALIMENTAZIONE
 POWER SUPPLY
 ALIMENTATION
 EINSPEISUNG
 STROOMVERZORGING
 ALIMENTACION
 STRØMFORSYNING
 STRØMFORSYNING
 ELFÖRSÖRJNING
 ЭЛЕКТРОПИТАНИЕ
 电源



START

(0:n) MIDDLE/END ...

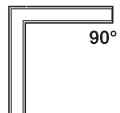
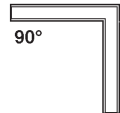

START
 (0:n) MIDDLE/END ...

START
 (0:n) MIDDLE/END ...

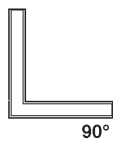

START

(0:n) MIDDLE/END ...



DETERMINAZIONE DELLE CORRENTI MASSIME AMMISSIBILI
 DETERMINING THE MAXIMUM PERMITTED CURRENT
 DETERMINATION DES COURANTS MAXIMAUX ADMISSIBLES
 BESTIMMUNG DER ZULÄSSIGEN HÖCHSTSTRÖME
 VASTSTELLEN VAN DE MAXIMAAL TOEGESTANE STROOMTOEVOER
 DETERMINACIÓN DE LAS CORRIENTES MÁXIMAS PERMITIDAS
 BESTEMMELSE AF MAKS. TILLADT STRØMSTYRKE
 BESTEMME MAKSIMAL TILLATT STRØM
 FASTSTÄLLANDE MAX. TILLÅTEN STRÖM
 ОПРЕДЕЛЕНИЕ МАКСИМАЛЬНОГО ДОПУСТИМОГО ТОКА
 确定最大通过电流

- I** Nella progettazione dell'impianto illuminotecnico ed elettrico, determinare le correnti massime ammissibili, considerando i seguenti fattori:
 - 9A corrente nominale ammessa dai morsetti
 - coefficiente di sicurezza per tenere conto delle sovratensioni e contemporaneità;
 - corrente nominale assorbita dai singoli moduli (vedi tabella)
- GB** When planning the lighting and electrical system, determine the maximum permitted current, taking into account the following factors:
 - 9A the nominal current permitted by terminal block
 - safety coefficient to allow for excess voltage and contemporaneity
 - the nominal current absorbed by single modules (see table)
- F** Lors de l'étude de projet de l'installation d'éclairage et de l'installation électrique, déterminer les courants maximaux admissibles en tenant compte des facteurs suivants :
 - 9A courant maximal admis par le bornier
 - coefficient de sécurité tenant compte des surtensions et de la simultanéité;
 - courant nominal absorbé par les différents modules (voir tableau)
- D** Bei der Planung einer Beleuchtungs- und Elektroanlage bestimmen Sie die zulässigen Höchstströme unter Berücksichtigung folgender Faktoren:
 - 9A von den Klemmleiste zugelassener Nennstrom
 - Sicherheitskoeffizient zur Einbeziehung von Überspannung und Gleichzeitigkeit;
 - von den einzelnen Modulen aufgenommenen Nennstrom (siehe Tabelle)
- NL** Bij het ontwerpen van de verlichtingstechnische en elektrische installatie moet u de maximaal toegestane stroomtoevoer vaststellen door rekening te houden met de volgende factoren:
 - 9A nominale stroom toegestaan op klemmenstroken
 - veiligheidscoëfficiënt om rekening te houden met overspanning en gelijktijdigheid;
 - nominale opgenomen stroom van de enkele modules (zie tabel)
- E** Durante la proyectación de la instalación luminotécnica y eléctrica, determinar las corrientes máximas permitidas, en consideración de los factores siguientes:
 - 9A corriente nominal permitida de la bornera
 - coeficiente de seguridad para considerar sobretensiones y contemporaneidades
 - corriente nominal absorbida por los módulos individuales (ver tabla)
- DK** I projekteringen af det belysningstekniske og elektriske anlæg, skal man undersøge den maks. tilladte strømstyrke, idet man tager højde for følgende:
 - 9A den nominelle, tilladte strømstyrke fra klæmkerne
 - sikkerhedsfaktor for at sikre mod overspænding og samtidighedsfaktor
 - absorberet nominal strømstyrke på de enkelte moduler (se tabellen).
- N** Ved planlegging av lys- og elektrisk system, bestem maksimalt tillatt strøm, ta med i betraktningen følgende faktorer:
 - 9A nominell strøm tillatt av terminalblokkene
 - sikkerhetskoeffisiens for å tillate overflødig spenning og aktualitet,
 - nominell strøm absorbert av enkeltmoduler (se tabell)
- S** Vid projekteringen av belysningsssystemet och det elektriska systemet ska max. tillåten ström fastställas. Ta hänsyn till följande faktorer:
 - 9A Tillåten nominell ström från kopplingsplintarna
 - Säkerhetskoefficient för att ta hänsyn till överspänningar och sammanlagningar.
 - Tillförd nominell ström från enskilda moduler (se tabell).
- RUS** При расчёте светотехнической системы и электропроводки определите максимальный допустимый ток с учетом следующих факторов:
 - 9А номинальный допустимый ток на клеммных колодках
 - коэффициент безопасности для учета перенапряжения и одновременного включения различных приборов;
 - номинальный ток, поглощаемый отдельными модулями (см. таблицу)
- CN** 规划照明和电路系统时，确定最大允许电流，并考虑下列因素：
 - 9A 接线排 允许的正常工作电流
 - 允许超过规定电压和同时性的安全系数；
 - 为单个模块使用的常规电流（见表）

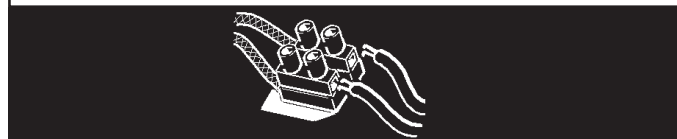
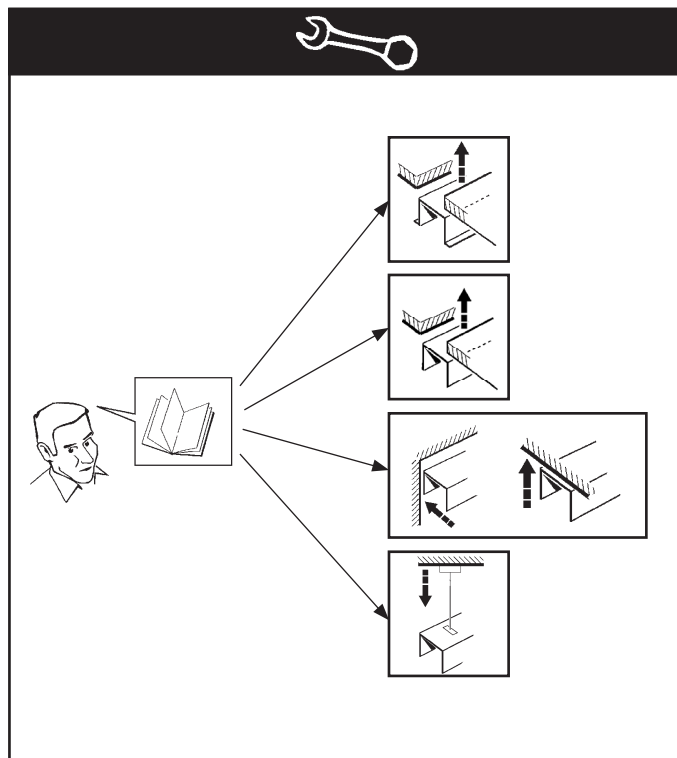
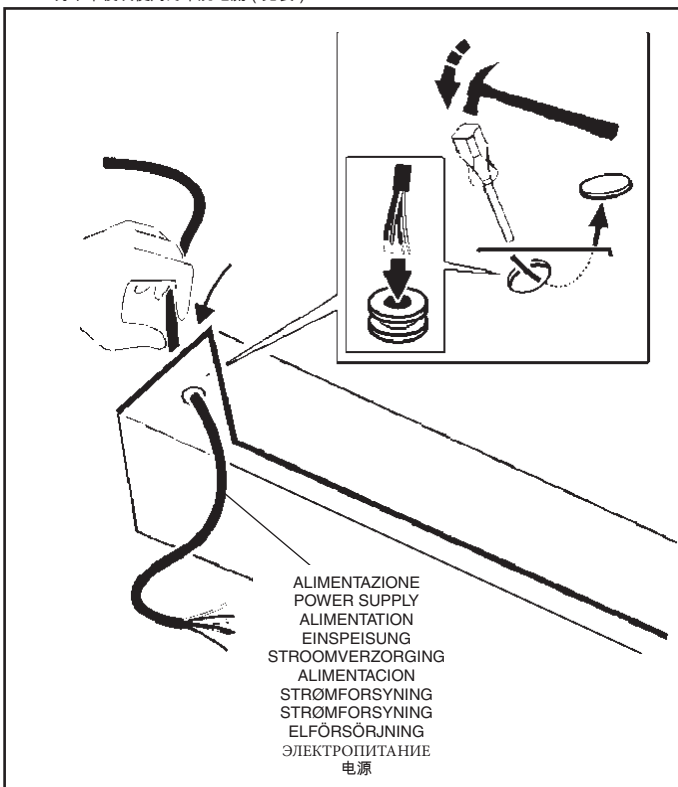

- I** Utilizzare l'art. MY44 ogni qual volta è necessario effettuare una nuova calata di alimentazione . (vedere tabella delle correnti massime ammissibili.)
- GB** Use item MY44 whenever it is necessary to effect a new power extension. (see maximum tolerable currents table)
- F** Utiliser l'art. MY44 chaque fois qu'il faut réaliser une nouvelle arrivée d'alimentation (voir le tableau des courants maximaux admissibles).
- D** Für jede neue Aufhängung zur Stromversorgung muss der Art. MY44 verwendet werden. (siehe Tabelle der zulässigen Höchstströme.)
- NL** Gebruik het art. MY44 elke keer dat het noodzakelijk is een nieuwe directe bekabeling uit te voeren vanaf het lichtnet. (zie tabel van de maximaal toegestane stroom.)
- E** Utilizar el art. MY44 cada vez que se necesita efectuar una nueva alimentación intermedia. (véase tabla de las corrientes máximas permitidas)
- DK** Anvend art. MY44, når det er nødvendigt at udføre et nyt forsyningsfald (se tabel over maksimalt tilladte strøm).
- N** Bruk art.MY44 hver gang du trenger å redusere strømtilførselen igjen (se tabellen for maks. tillatt strømstyrke).
- S** Använd art. MY44 varje gång som det är nödvändigt att utföra en ny nätslutning. (se tabellen för tillåten maximiström.)
- RUS** Использовать арт. MY44 для каждого независимого подвода питания (см. таблицу максимально допустимого тока).
- CN** 每次执行新的电源下降时使用零件MY44 (参见最大允许电流表格) 。

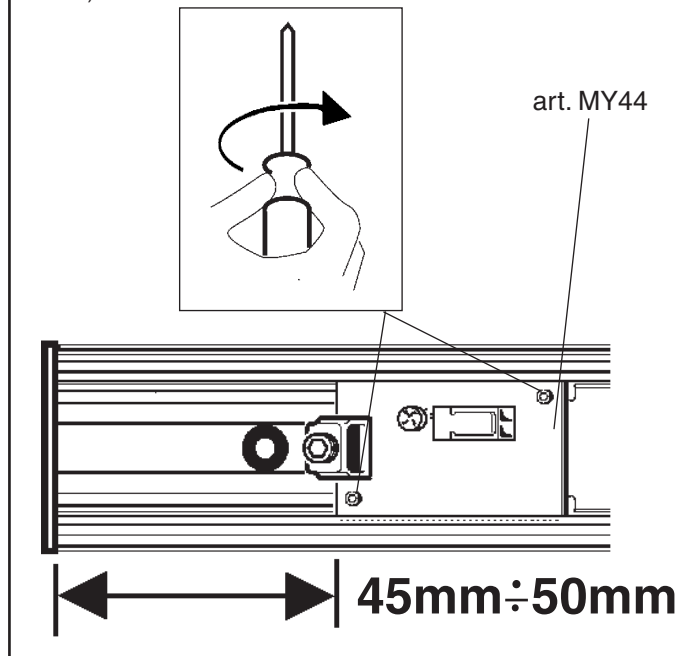

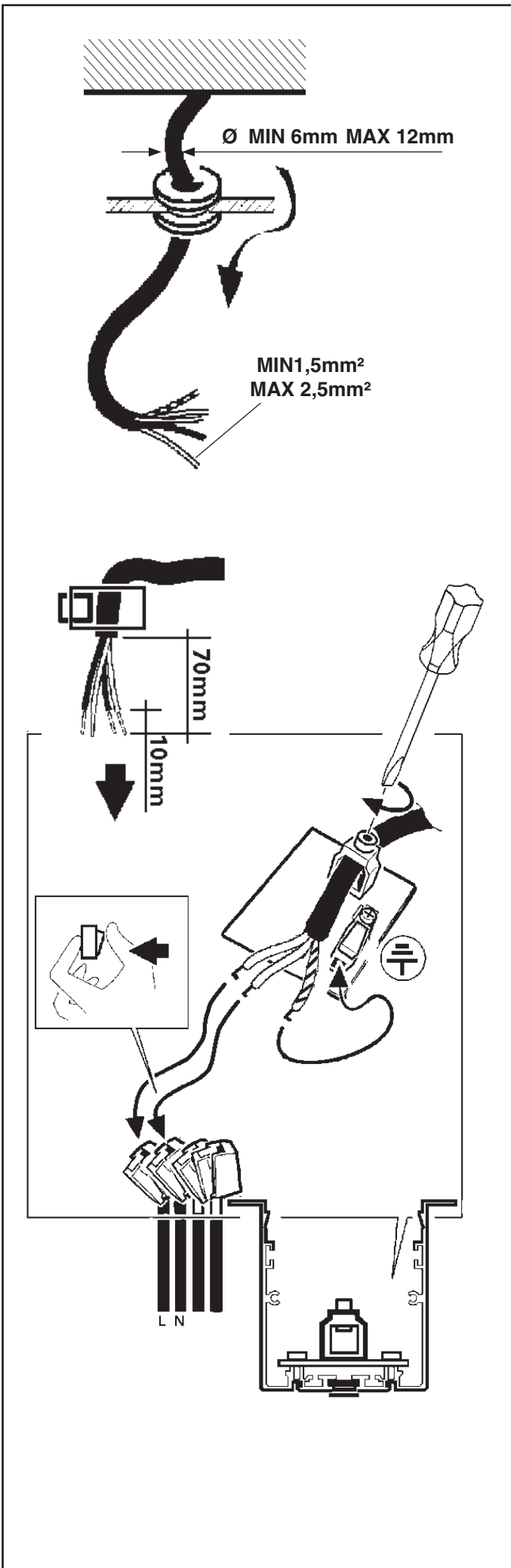

DALI

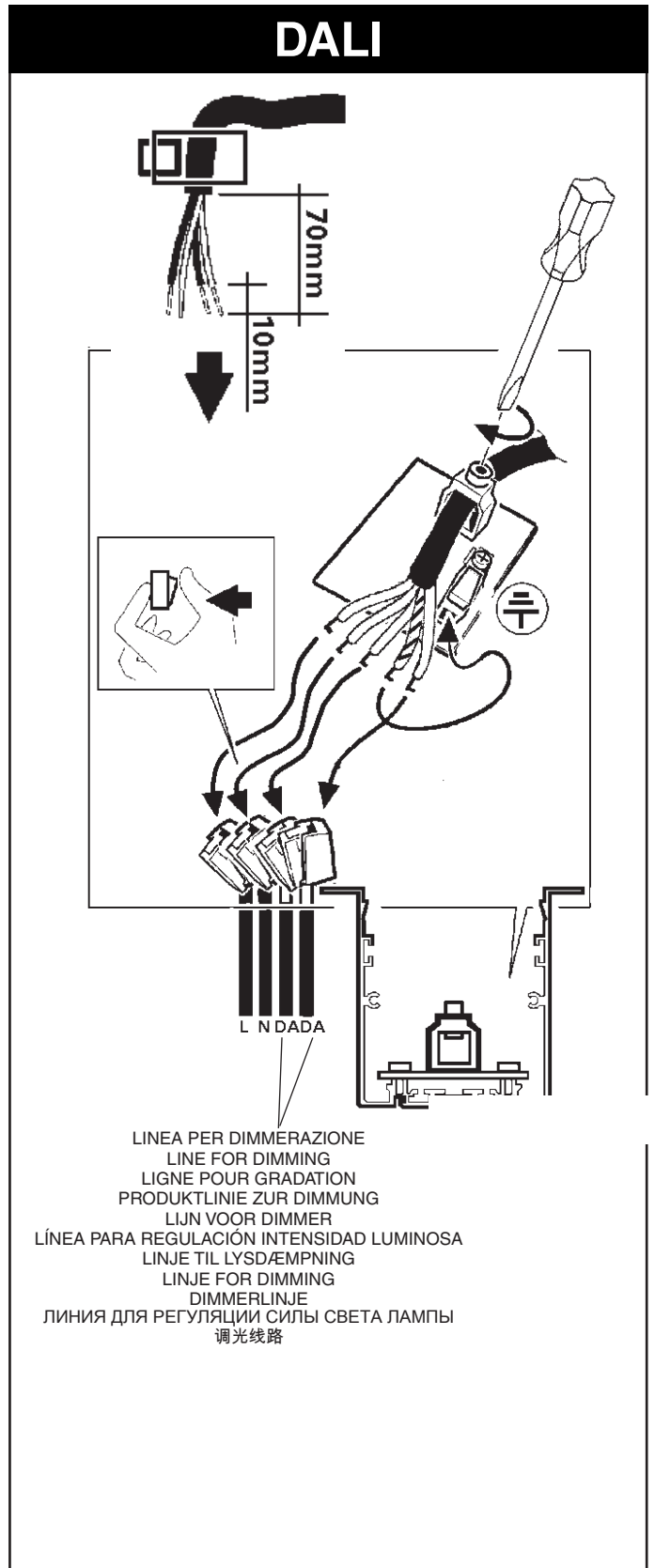

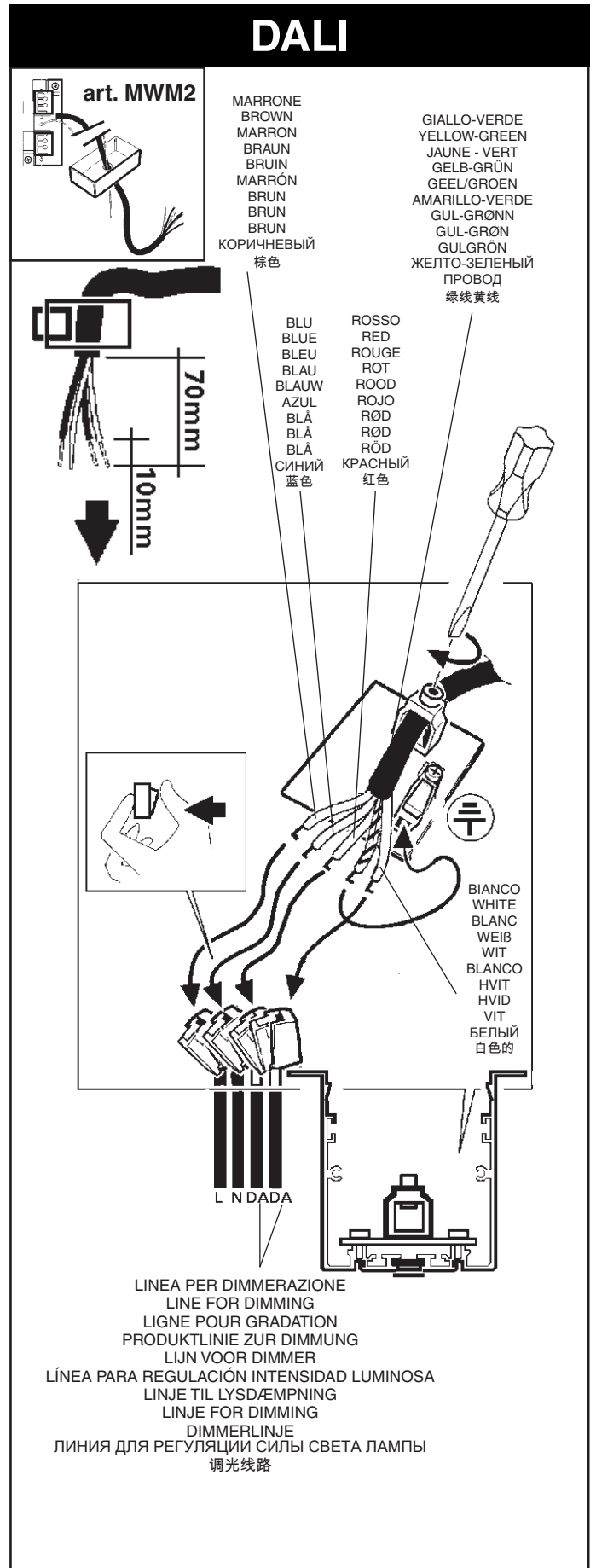
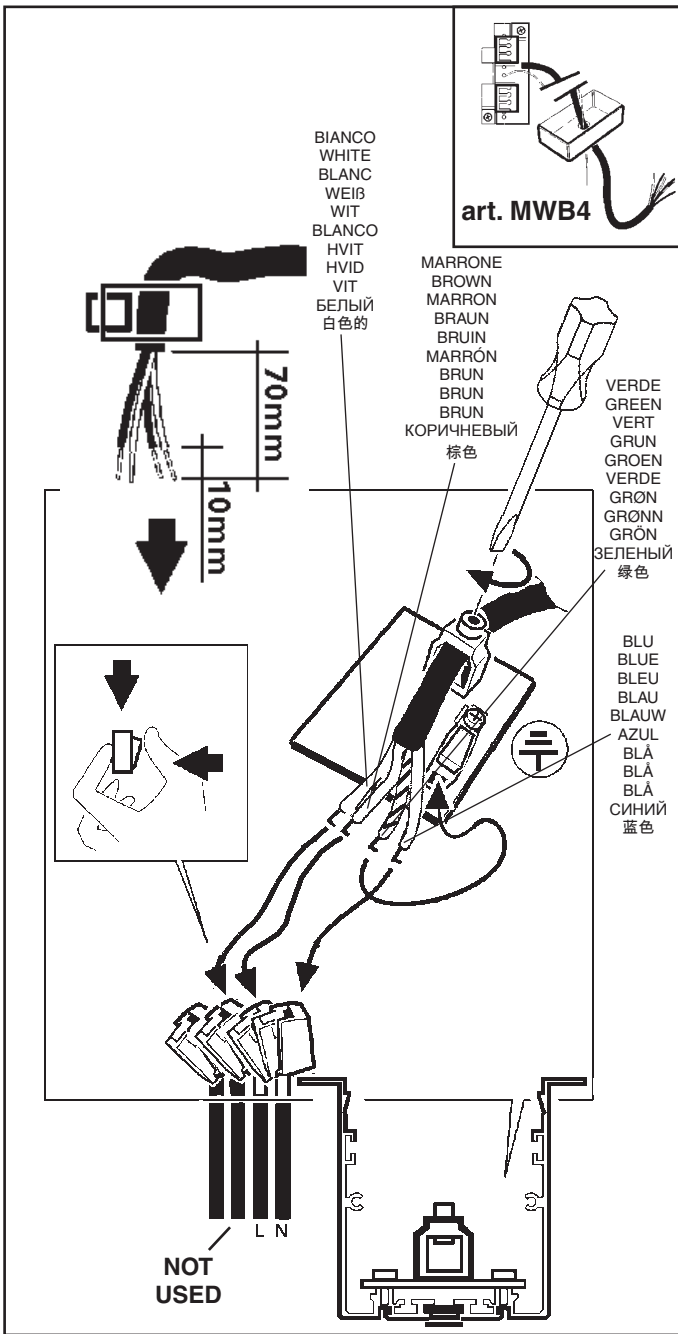

TOUCH DIM

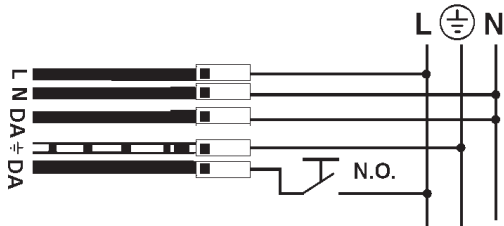

- I I dispositivi con cablaggio digitale possono essere dimmerati con dispositivi DALI o con pulsante normalmente aperto (N.O.) da collegare come da schema.
- GB Devices with digital control gear may be dimmed using DALI devices or a normally-open button (N.O.) to be connected as shown in the diagram.
- F Les articles à câblage numérique peuvent fonctionner avec des variateurs à dispositifs DALI ou à bouton poussoir normalement ouvert (N.O.) à relier conformément au schéma.
- D Die Geräte mit digitaler Verkabelung können mit Hilfe von DALI-Vorrichtungen oder mit Hilfe eines gemäß Schaltplan anzuschließenden Schließers (N.O.) gedimmt werden.
- NL De producten met digitale bekabeling kunnen worden gedimd met DALI systemen of met een N.O. (normally open) knop, die moet worden aangesloten volgens schema.
- E Los dispositivos con cableado digital pueden regularse con dispositivos DALI o con un interruptor de botón normalmente abierto (N.O.) que se conecta según ilustrado en el esquema.
- DK Produkter med digital kabelføring kan dæmpes med DALI-anordninger eller med kontakten, som normalt er åben (N.O.) og som skal tilsluttes, som vist.
- N Produkter med digitalkabler kan dimmes med DALI-anordninger eller med en normalt åpen (NO) trykkbryter som kobles som vist i koblingsskjema.
- S Produkter med digital kabeldragning kan förösas med dimmer. Detta kan göras med DALI-anordningarna eller med en normalt öppen kontakt (N.O.) som ska anslutas enligt schemat.
- RUS Интенсивность приборов с цифровой проводкой может регулироваться посредством устройств DALI или нормально разомкнутой кнопкой (Н.Р.), подсоединяемой согласно схеме.
- CN 带有数字控制装置的设备可以通过 DALI (数字化可寻址调光接口) 设备或者一个连接方式如图中所示的常开按钮 (N.O.) 进行亮度调节

- I Pilotare diversi prodotti DALI tramite pulsante (es: Touch-dim, Switch-dim, Push-dim, Direct-dim, etc.) potrebbe causare dei problemi di sincronizzazione tra gli stessi. È possibile ovviare a questo problema dotandosi di dispositivi aggiuntivi. Per maggiori informazioni vi invitiamo a contattarci direttamente.
- GB Controlling different DALI products through buttons (e.g.: Touch-dim, Switch-dim, Push-dim, Direct-dim, etc.) may lead to product synchronisation problems. This problem can be overcome by using additional devices. For further information, please contact us directly.
- F Pilotez plusieurs produits DALI par bouton (ex : Touch-dim, Switch-dim, Push-dim, Direct-dim, etc.) pourrait causer des problèmes de synchronisation entre eux. Ce problème peut être évité en s'équipant de dispositifs supplémentaires. Pour de plus amples renseignements, veuillez nous contacter directement.
- D Die Steuerung verschiedener DALI-Produkte mittels Taste (z.B.: Touch-dim, Switch-dim, Push-dim, Direct-dim etc.) kann eventuell zu Synchronisierungsproblemen zwischen diesen führen. Dieses Problem lässt sich durch den Einsatz von zusätzlichen Geräten beheben. Wenn Sie weitere Informationen wünschen, setzen Sie sich bitte direkt mit uns in Verbindung.
- NL Het besturen van verschillende DALI producten m.b.v. dezelfde knop (bv.: Touch-dim, Switch-dim, Push-dim, Direct-dim, etc.) kan synchronisatieproblemen tussen de producten opleveren. Men kan dit probleem voorkomen door extra systemen aan te sluiten. Voor verdere informatie raden we u aan direct contact met ons op te nemen.
- E El mando de varios productos DALI por tecla (ej: Touch-dim, Switch-dim, Push-dim, Direct-dim, etc.) podría causar problemas de sincronización entre ellos. Es posible prevenir este problema utilizando dispositivos adicionales. Para más información, contacte directamente con nosotros.
- DK Hvis DALI-produkterne styres ved hjælp af knapperne (fx. Touch-dim, Switch-dim, Push-dim, Direct-dim osv.), kan det skabe problemer med synkronisering af samme. Dette problem kan undgås, hvis man køber ekstra enheder. For yderligere oplysninger, kontakt os direkte.
- N Å styre ulike DALI-produkter ved hjelp av en trykknappbryter (f.eks. touch-dim, switch-dim, push-dim, direct-dim, osv.) vil kunne føre til problemer med synkroniseringen mellom dem. Dette problemet kan løses ved hjelp av noen tilleggsinnretninger. Ta gjerne kontakt med oss for mer informasjon om dette.
- S Styrning av olika DALI-produkter med knapp (t.ex.: Touch-dim, Switch-dim, Push-dim, Direct-dim o.s.v.) kan orsaka synkroniseringsproblem mellan dessa. Detta problem kan åtgärdas med tilläggsanordningar. För mer information kan du kontakta oss direkt.
- RUS Управление различными продуктами DALI с помощью кнопки (напр.: Touch-dim, Switch-dim, Push-dim, Direct-dim и пр.) может вызвать проблемы синхронизации между ними. Эту проблему можно устранить путем задействования дополнительных устройств. За получением более подробной информации просим Вас связаться с нами непосредственно.
- CN 通过按钮控制不同的 DALI 产品 (例如: 触摸调光、切换调光、按压调光、直接调光等) 可能会导致产品的同步问题。该问题可通过使用其他额外的装置加以克服。如需了解更多信息, 请直接与我们联系。

CARICO DALI / DALI LOAD CHARGE DALI (COURANT MAXI ADMISSIBLE) DALI-LAST DALI VERMOGEN CARGA DALI DALI STRØMSTYRKE BELASTNING FOR "DALI" DALI-BELASTNING МАКС. ТОК СИСТЕМЫ DALI С РЕГУЛЯЦИЕЙ ИНТЕНСИВНОСТИ СВЕТА DALI 智能调光系统允许的最大电流值	INDIRIZZI DALI DALI ADDRESSES ADRESSES DALI DALI-ADRESSEN DALI ADRESSEN DIRECCIONES DALI DALI ADRESSER ADRESSER TIL "DALI" DALI-ADRESSER СИСТЕМЫ DALI DALI 智能调光系统计算机指定控制参数
1 (2 mA)	1

Es.



START

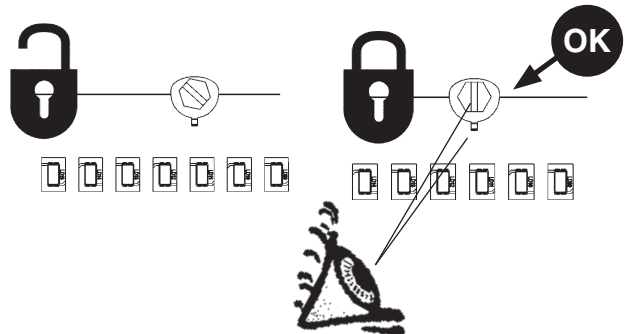
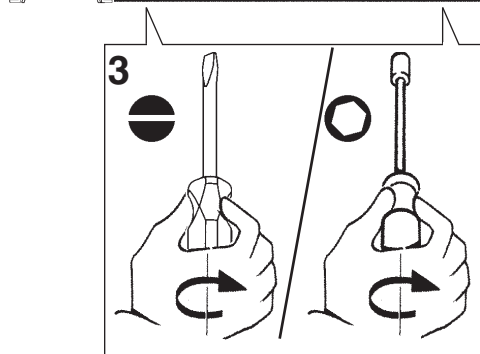
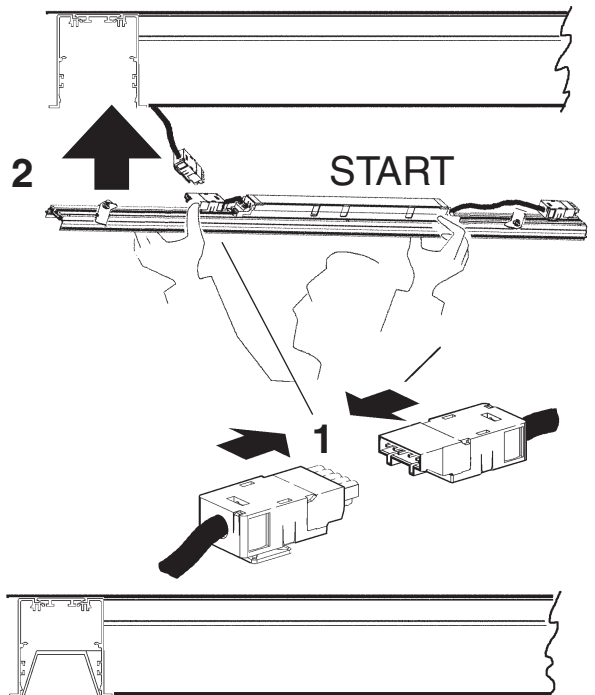

Es.  START (0:n) MIDDLE/END END

START/ MIDDLE

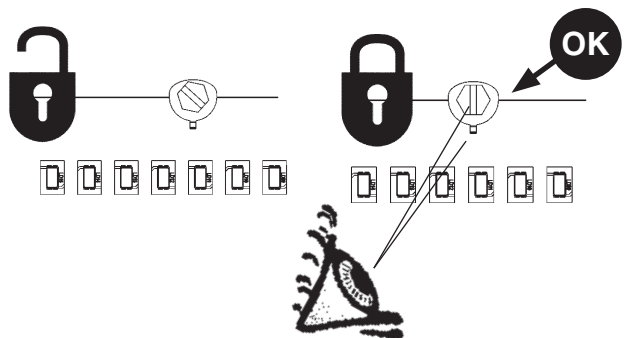
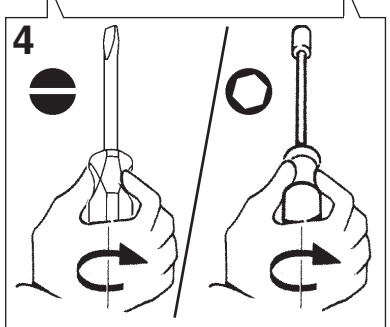
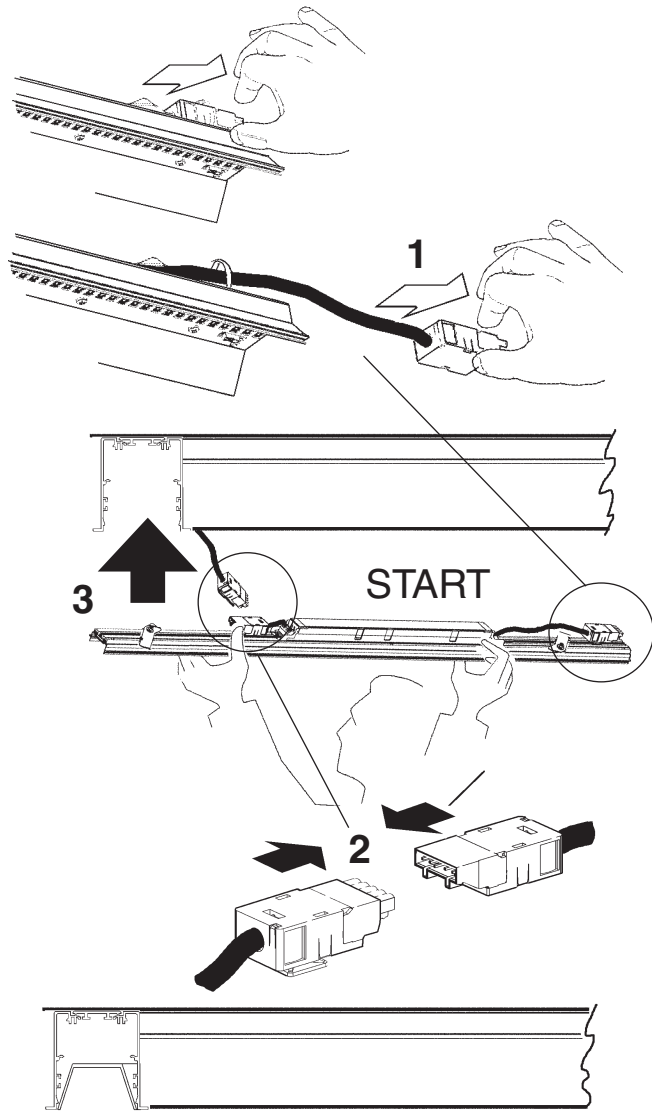

END

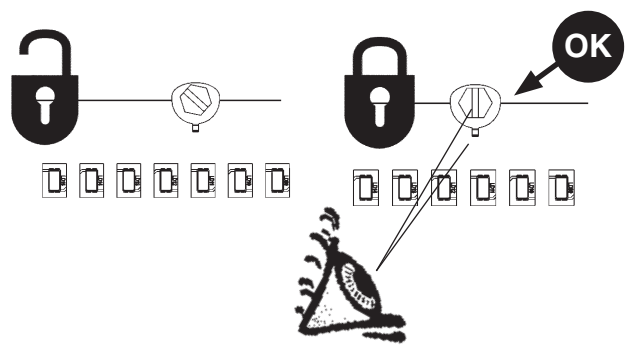
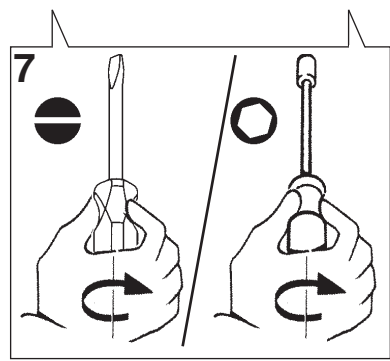
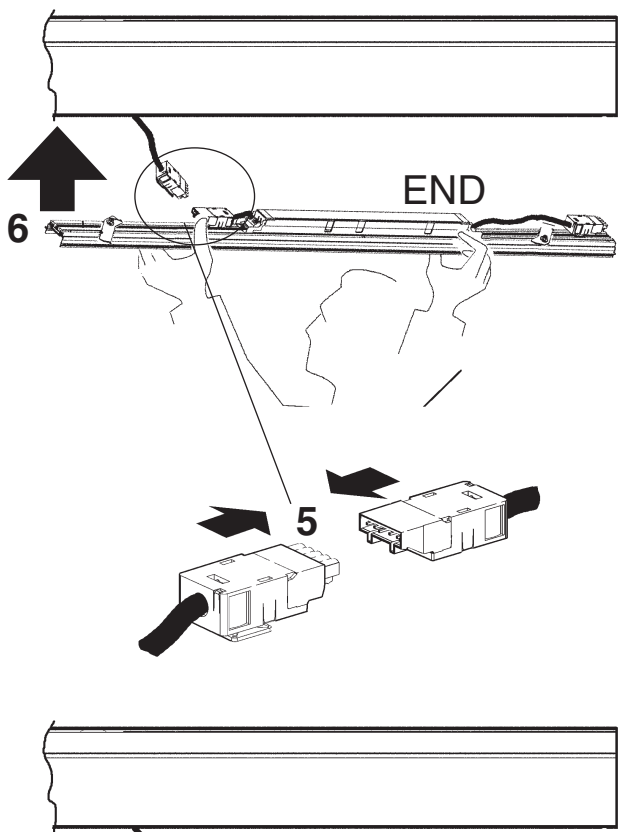

Es.

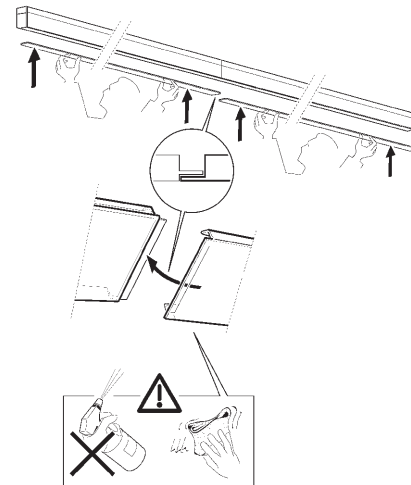
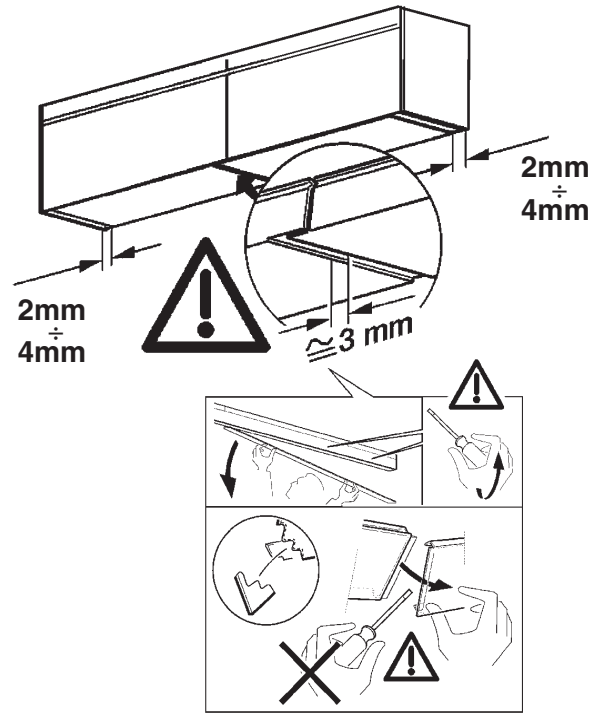
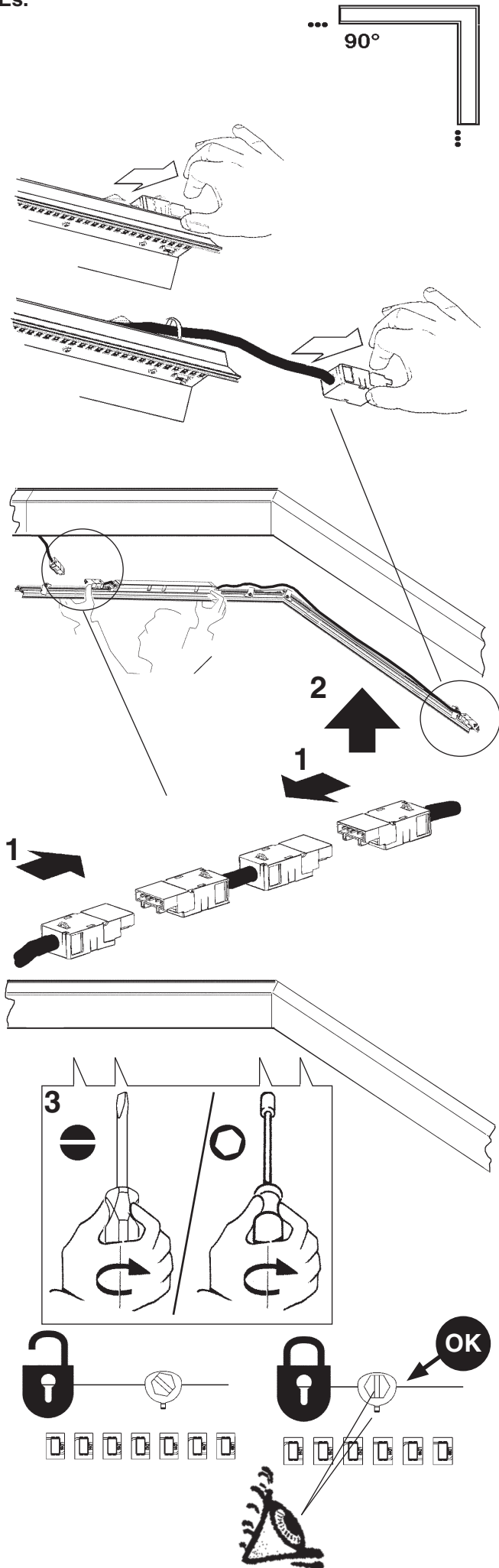

I N.B.: Per l'eventuale pulizia non utilizzare acqua o solventi vari, usare esclusivamente panni morbidi asciutti.

GB N.B.: When cleaning, do not use water or any type of solvent. Use only soft dry cloths.

F N.B.: En cas de nettoyage, n'utiliser ni eau ni solvants en général, n'utiliser que des chiffons doux et secs.

D N.B.: Zur eventuellen Reinigung weder Wasser noch Lösungsmittel, sondern ausschließlich ein weiches, trockenes Tuch verwenden.

NL N.B.: Gebruik voor het schoonmaken geen water of oplosmiddelen, maar uitsluitend zachte stofdoeken.

E NOTA: Para la limpieza eventual no usar agua ni solventes de cualquier género, sino exclusivamente un pano suave y seco.

DK N.B.: Ved rengøring skal man undgå brug af vand eller forskellige opløsningsmidler. Brug udelukkende en tør, blød klud.

N N.B.: For en eventuell rengjøring, ikke benytt vann eller ymse løsemidler, bruk kun tørre, myke kluter.

S OBS! Använd inte vatten eller diverse lösningsmedel vid eventuell rengöring. Använd endast mjuka och torra trasor.

RUS ПРИМЕЧАНИЕ: При необходимости произвести чистку не используйте воду или различные растворители, а исключительно сухие мягкие тряпки.

CN 注意：不要用水或任何类型的溶剂进行清洗。只能使用干燥的软布。

I N.B.: Per la sostituzione del LED contattare l'azienda iGuzzini.

GB N.B.: For information on LED replacement please contact iGuzzini.

F N.B.: Pour procéder au remplacement de la LED, adressez-vous à la société iGuzzini.

D N.B.: Bezüglich des Austausches der LED kontaktieren Sie bitte die Firma iGuzzini.

NL N.B.: Voor het vervangen van de LED neemt u contact op met het bedrijf iGuzzini.

E NOTA: Para sustituir el LED llame a la empresa iGuzzini.

DK N.B.: For udskiftning af lysdioden, skal man kontakte iGuzzini.

N N.B.: For informasjon om skifte av LED, vennligst ta kontakt med iGuzzini.

S OBS! För byte av lysdioden, kontakta företaget iGuzzini.

RUS ПРИМЕЧАНИЕ: Для замены СИДов обращайтесь в компанию iGuzzini.

CN 注意：如需LED更换的信息，请联系iGuzzini。

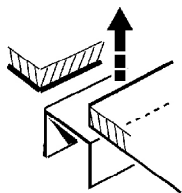

iN90 Led (MINIMAL)

I ATTENZIONE:

LA SICUREZZA DELL'APPARECCHIO E' GARANTITA SOLO CON L'USO APPROPRIATO DELLE SEGUENTI ISTRUZIONI; PERTANTO E' NECESSARIO CONSERVARLE.

GB WARNING:

THE SAFETY OF THIS FIXTURE IS GUARANTEED ONLY IF YOU COMPLY WITH THESE INSTRUCTIONS; REMEMBER TO CONSERVE IN A SAFE PLACE.

F ATTENTION:

LA SECURITE DEL'APPAREIL N'EST GARANTIE QU'EN CAS D'UTILISATION CORRECTE DES INSTRUCTIONS SUIVANTES; IL FAUT PAR CONSEQUENT LES CONSERVER.

D ACHTUNG:

DIE SICHERHEIT DES GERÄTES WIRD NUR DURCH SACHGEMÄSSE BEFOLGUNG NACHSTEHENDER ANWEISUNGEN GEWÄHRLEISTET; IHRE AUFBEWAHRUNG IST DESHALB SEHR WICHTIG.

NL OPGELET:

DE VEILIGHEID VAN DI ATOESTEL IS SLECHTS DAN GEGARANDEERD ALS INDIEN DE VOLGENDE INSTRUCTIES STRIKT WORDEN TOEGEPAST: DAAROM MOET MEN ZE OOK BEWAAREN.

E ATENCION:

LA SEGURIDAD DEL APARATO SE GARANTIZA SOLO CUMPLIENDO CUIDADOSAMENTE LAS SIGUIENTES INSTRUCCIONES; POR ELLO, ES NECESARIO CONSERVARLAS.

DK BEMÆRK:

SIKKERHEDEN VED BRUG AF ARMATURET KAN KUN GARANTERES, HVIS DISSE ANVISNINGER FØLGES; SØRG DERFOR FOR AT GEMME DEM.

N ADVARSEL:

SIKKERHETEN TIL DETTE APPARATET GARANTERES KUN HVIS DU OVERHOLDER DISSE INSTRUKSJONENE; HUSK Å OPPBEVARE DEM PÅ ET TRYGT STED.

S OBSERVERA!

UTRUSTNINGENS SÄKERHET KAN ENDAST GARANTERAS OM DESSA ANVISNINGAR RESPEKTERAS I DETALJ. SPARA DÄRFÖR DESSA ANVISNINGAR FÖR FRAMTIDA KONSULTATION.

RUS ВНИМАНИЕ:

МЫ ГАРАНТИРУЕМ БЕЗОПАСНУЮ ЭКСПЛУАТАЦИЮ ИЗДЕЛИЯ ТОЛЬКО ПРИ СОБЛЮДЕНИИ СЛЕДУЮЩИХ ИНСТРУКЦИЙ; С ЭТОЙ ЦЕЛЬЮ НЕОБХОДИМО СОХРАНИТЬ ДАННУЮ БРОШЮРУ.

CN 警告

为确保该装置安全，请遵守操作指示；并于安全场所放置。

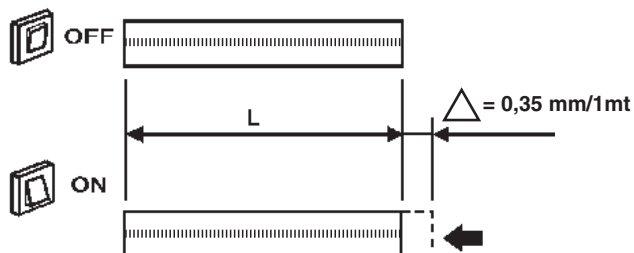
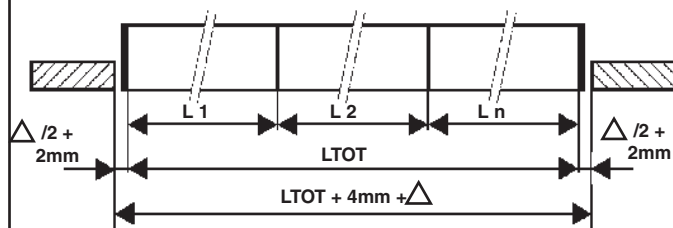
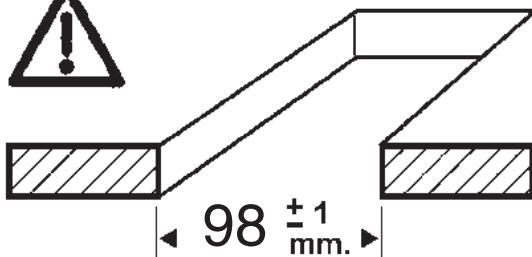
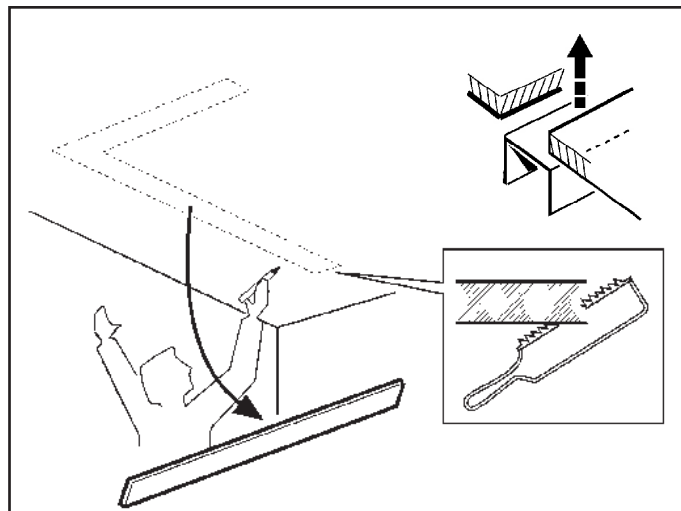
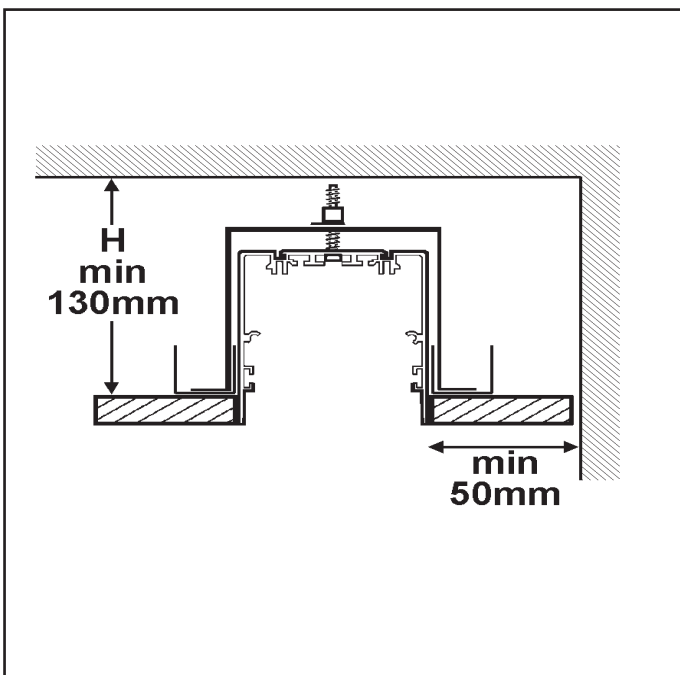

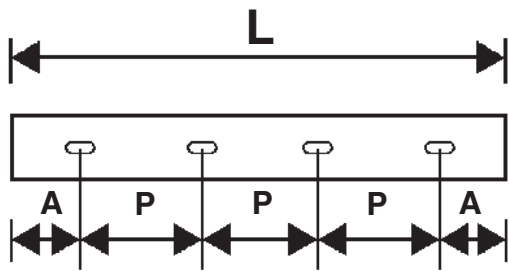

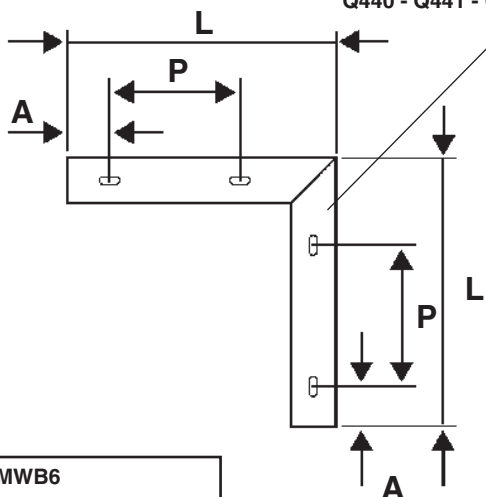

Q392 - Q393 - Q394 - Q395
Q440 - Q441 - Q442 - Q443

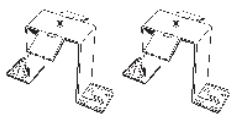

art. MWB6



ART.	L (mm)	P (mm)	A (mm)	
Q362 - Q426	612	250	181	2
Q363 - Q368 - Q427 - Q432	1208	500	354	2
Q364 - Q369 - Q428 - Q433	2397	1000	198,5	3
Q365 - Q370 - Q429 - Q434	3596	1000	298	4
Q366 - Q430	898	500	199	2
Q367 - Q371 - Q431 - Q435	3596	1000	298	4
Q392 - Q393 Q394 - Q395 Q440 - Q441 Q442 - Q443	658 x 658	250	181	4

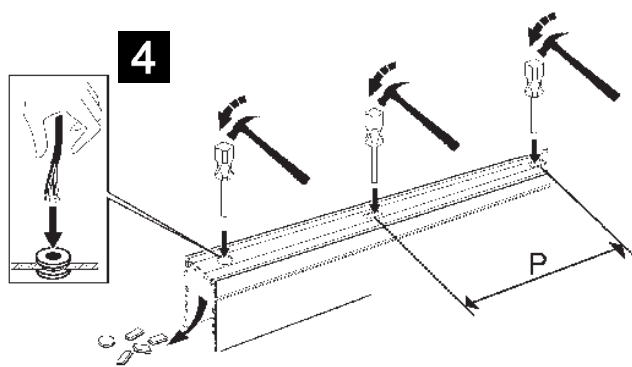
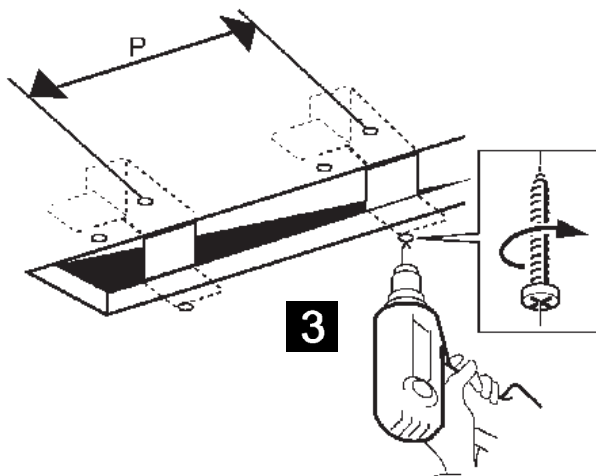
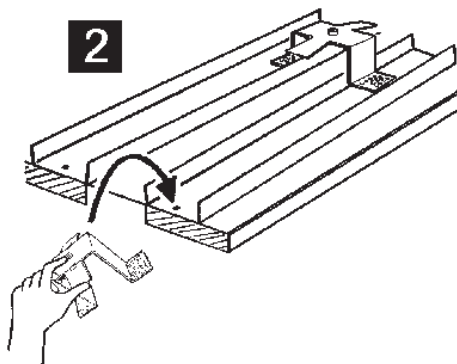
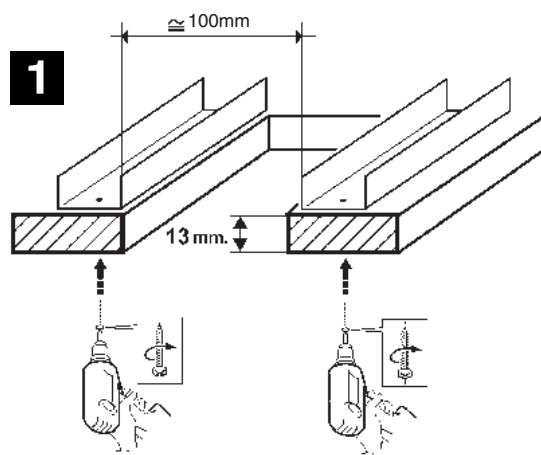

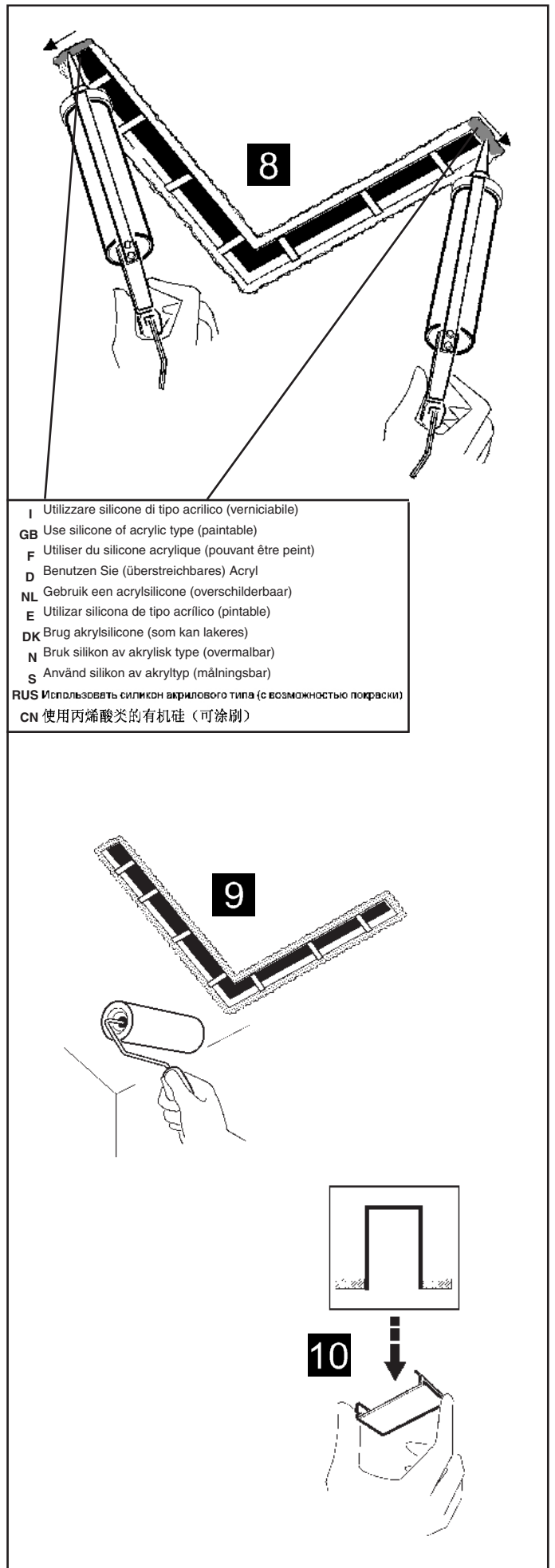
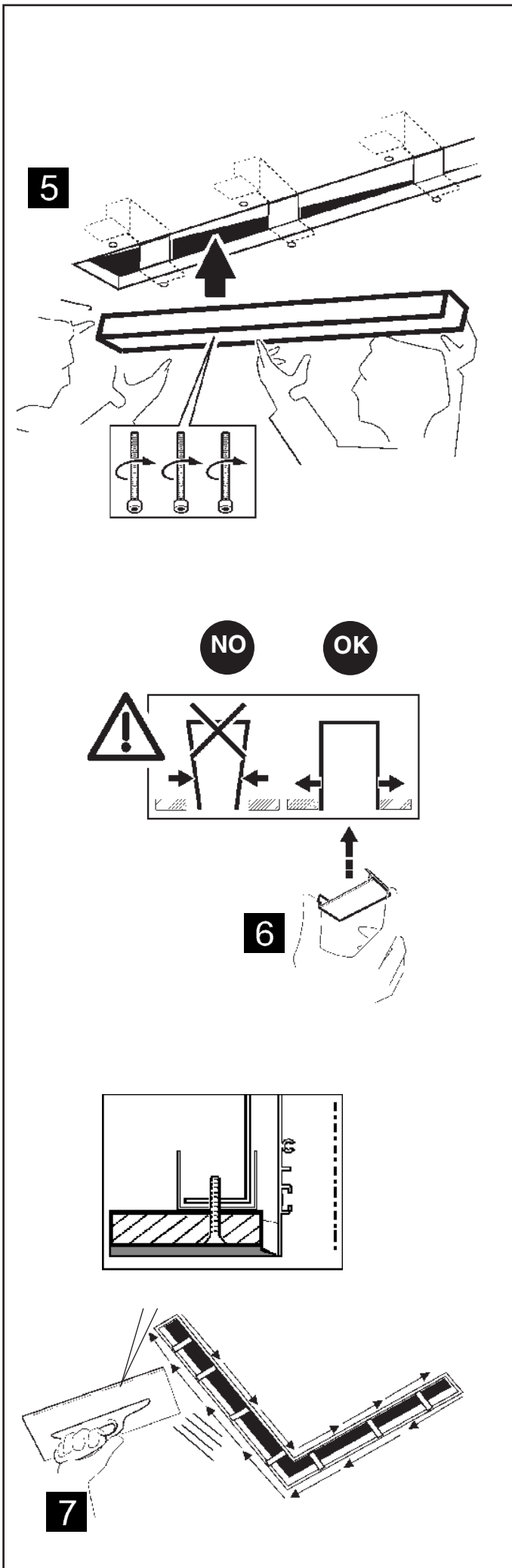

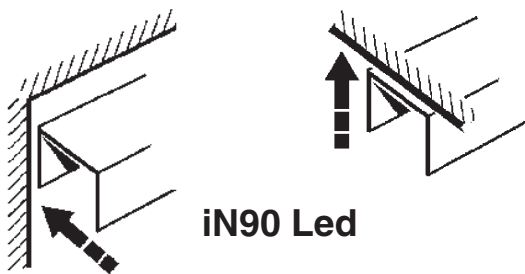

iN90 Led

I ATTENZIONE:

LA SICUREZZA DELL'APPARECCHIO E' GARANTITA SOLO CON L'USO APPROPRIATO DELLE SEGUENTI ISTRUZIONI; PERTANTO E' NECESSARIO CONSERVARLE.

GB WARNING:

THE SAFETY OF THIS FIXTURE IS GUARANTEED ONLY IF YOU COMPLY WITH THESE INSTRUCTIONS; REMEMBER TO CONSERVE IN A SAFE PLACE.

F ATTENTION:

LA SECURITE DEL L'APPAREIL N'EST GARANTIE QU'EN CAS D'UTILISATION CORRECTE DES INSTRUCTIONS SUIVANTES; IL FAUT PAR CONSEQUENT LES CONSERVER.

D ACHTUNG:

DIE SICHERHEIT DES GERÄTES WIRD NUR DURCH SACHGEMÄSSE BEFOLGUNG NACHSTEHENDER ANWEISUNGEN GEWÄHRLEISTET; IHRE AUFBEWAHRUNG IST DESHALB SEHR WICHTIG.

NL OPGELET:

DE VEILIGHEID VAN DI ATOESTEL IS SLECHTS DAN GEGARANDEERD ALS INDIEN DE VOLGENDE INSTRUCTIES STRIKT WORDEN TOEGEPAST: DAAROM MOET MEN ZE OOK BEWAREN.

E ATENCION:

LA SEGURIDAD DEL APARATO SE GARANTIZA SOLO CUMPLIENDO CUIDADOSAMENTE LAS SIGUIENTES INSTRUCCIONES; POR ELLO, ES NECESARIO CONSERVARLAS.

DK BEMÆRK:

SIKKERHEDEN VED BRUG AF ARMATURET KAN KUN GARANTERES, HVIS DISSE ANVISNINGER FØLGES; SØRG DERFOR FOR AT GEMME DEM.

N ADVARSEL:

SIKKERHETEN TIL DETTE APPARATET GARANTERES KUN HVIS DU OVERHOLDER DISSE INSTRUKSJONENE; HUSK Å OPPBEVARE DEM PÅ ET TRYGT STED.

S OBSERVERA!

UTRUSTNINGENS SÄKERHET KAN ENDAST GARANTERAS OM DESSA ANVISNINGAR RESPEKTERAS I DETALJ. SPARA DÄRFÖR DESSA ANVISNINGAR FÖR FRAMTIDA KONSULTATION.

RUS ВНИМАНИЕ:

МЫ ГАРАНТИРУЕМ БЕЗОПАСНУЮ ЭКСПЛУАТАЦИЮ ИЗДЕЛИЯ ТОЛЬКО ПРИ СОБЛЮДЕНИИ СЛЕДУЮЩИХ ИНСТРУКЦИЙ; С ЭТОЙ ЦЕЛЬЮ НЕОБХОДИМО СОХРАНИТЬ ДАННУЮ БРОШЮРУ.

CN 警告

为确保该装置安全，请遵守操作指示；并于安全场所放置。



art. Q426 - Q427
Q428 - Q429
Q430 - Q431
Q432 - Q433
Q434 - Q435

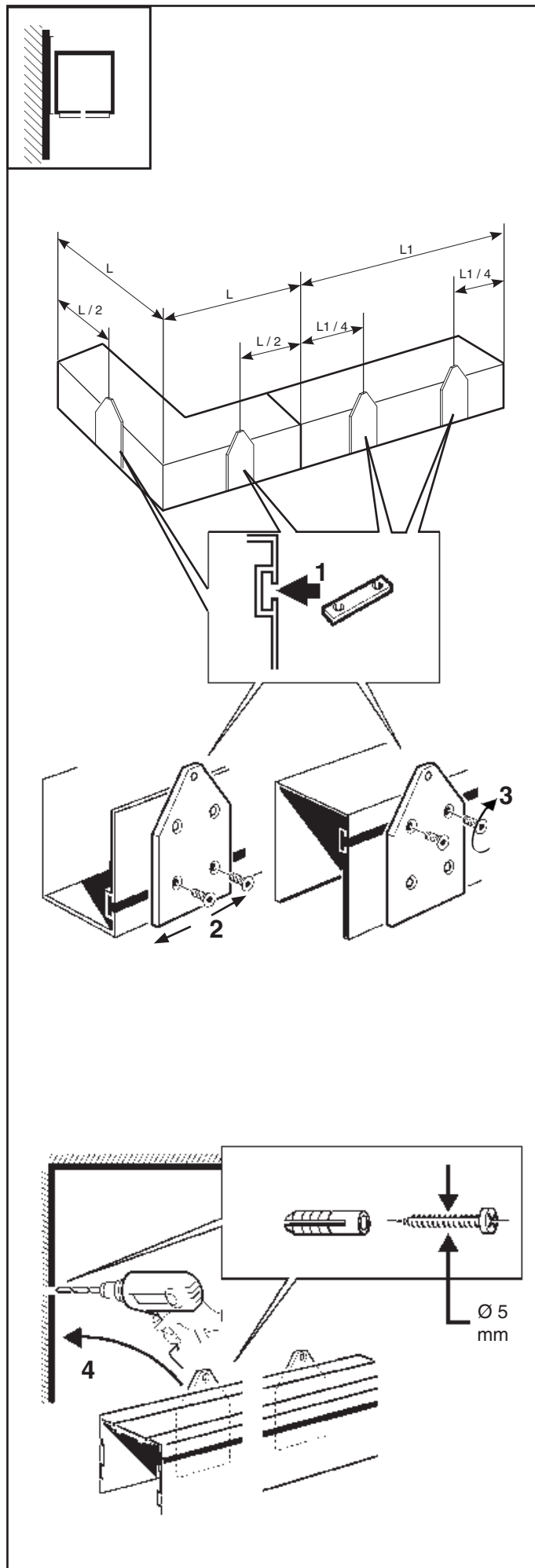

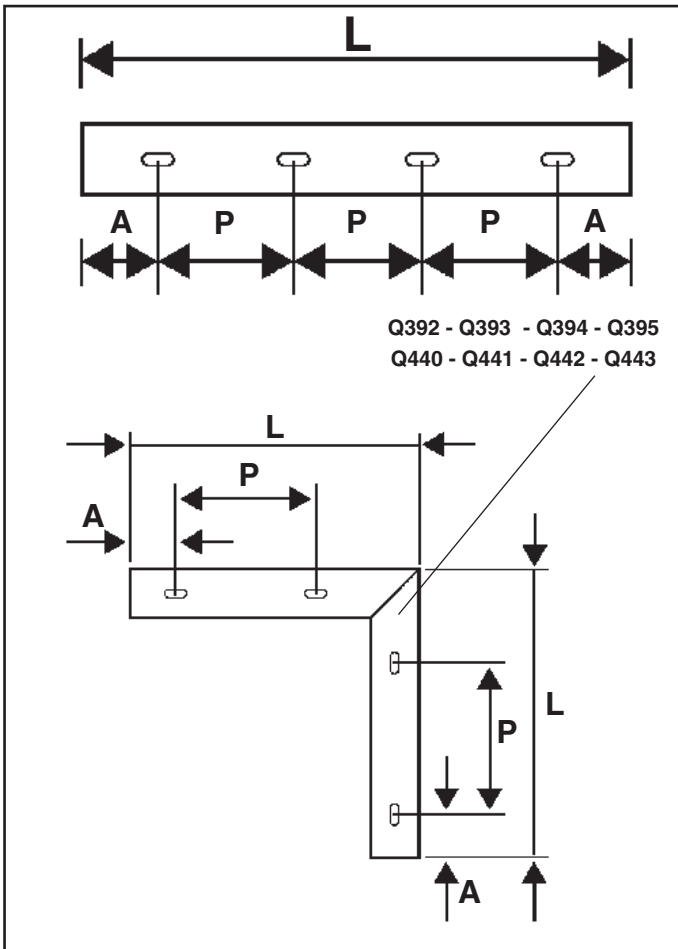
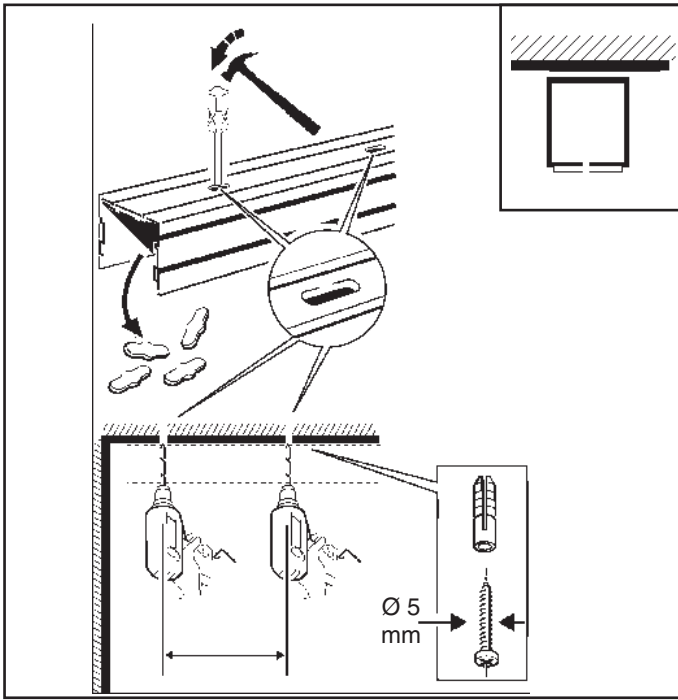

ART.	L (mm)	P (mm)	A (mm)	
Q362 - Q426	612	250	181	2
Q363 - Q368 - Q427	1208	500	354	2
Q364 - Q369 - Q428	2397	1000	198,5	3
Q365 - Q370 - Q429	3596	1000	298	4
Q366 - Q430	898	500	199	2
Q367 - Q371 - Q431	3596	1000	298	4
Q392 - Q393 Q394 - Q395 Q440 - Q441 Q442 - Q443	658 x 658	250	181	4

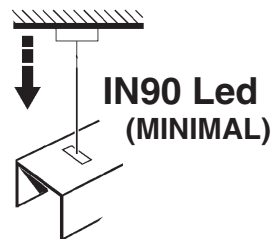

I ATTENZIONE:

LA SICUREZZA DELL'APPARECCHIO E' GARANTITA SOLO CON L'USO APPROPRIATO DELLE SEGUENTI ISTRUZIONI; PERTANTO E' NECESSARIO CONSERVARLE.

GB WARNING:

THE SAFETY OF THIS FIXTURE IS GUARANTEED ONLY IF YOU COMPLY WITH THESE INSTRUCTIONS; REMEMBER TO CONSERVE IN A SAFE PLACE.

F ATTENTION:

LA SECURITE DE L'APPAREIL N'EST GARANTIE QU'EN CAS D'UTILISATION CORRECTE DES INSTRUCTIONS SUIVANTES; IL FAUT PAR CONSEQUENT LES CONSERVER.

ACHTUNG:

DIE SICHERHEIT DES GERÄTES WIRD NUR DURCH SACHGEMÄSSE BEFOLGUNG NACHSTEHENDER ANWEISUNGEN GEWÄHRLEISTET; IHRE AUFBEWAHRUNG IST DESHALB SEHR WICHTIG.

NL OPGELET:

DEVEILIGHEID VAN DI ATOESTEL IS SLECHTS DAN GEGARANDEERD ALS INDIEN DE VOLGENDE INSTRUCTIES STRIKT WORDEN TOEGEPAST; DAAROM MOET MEN ZE OOK BEWAREN.

E ATENCION:

LA SEGURIDAD DEL APARATO SE GARANTIZA SOLO CUMPLIENDO CUIDADOSAMENTE LAS SIGUIENTES INSTRUCCIONES; POR ELLO, ES NECESARIO CONSERVARLAS.

DK BEMÆRK:

SIKKERHEDEN VED BRUG AF ARMATURET KAN KUN GARANTERES, HVIS DISSE ANVISNINGER FØLGES; SØRG DERFOR FOR AT GEMME DEM.

N ADVARSEL:

SIKKERHETEN TIL DETTE APPARATET GARANTERES KUN HVIS DU OVERHOLDER DISSE INSTRUKSJONENE; HUSK Å OPPBEVARE DEM PÅ ET TRYGT STED.

S OBSERVERA!

UTRUSTNINGENS SÄKERHET KAN ENDAST GARANTERAS OM DESSA ANVISNINGAR RESPEKTERAS I DETALJ. SPARA DÄRFÖR DESSA ANVISNINGAR FÖR FRAMTIDA KONSULTATION.

RUS ВНИМАНИЕ:

МЫ ГАРАНТИРУЕМ БЕЗОПАСНУЮ ЭКСПЛУАТАЦИЮ ИЗДЕЛИЯ ТОЛЬКО ПРИ СОБЛЮДЕНИИ СЛЕДУЮЩИХ ИНСТРУКЦИЙ; С ЭТОЙ ЦЕЛЬЮ НЕОБХОДИМО СОХРАНИТЬ ДАННУЮ БРОШЮРУ.





CN 警告

为确保该装置安全，请遵守操作指示；并于安全场所放置。

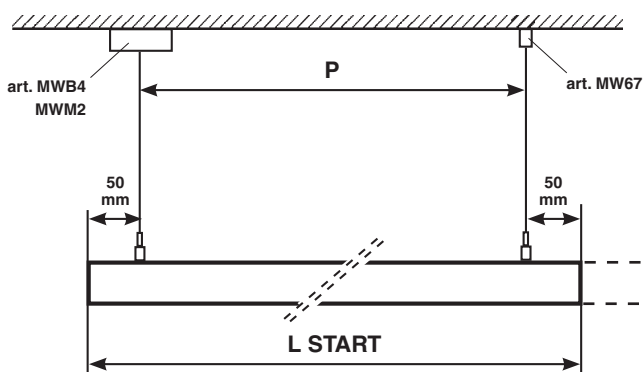
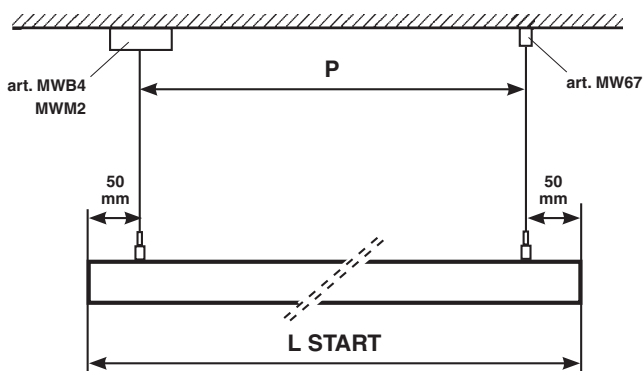
INSTALLAZIONE A SOSPENSIONE
SUSPENSION INSTALLATION
INSTALLATION EN SUSPENSION
INSTALLATION MIT STAHLSEILAUFHÄNGUNG
HET OPHANGEN
INSTALACION COLGADA
PENDLENDE OPHÆNG
HENGINSTALLASJON
HÄNGANDE INSTALLATION
ПОДВЕСНОЙ МОНТАЖ
吊頂式安裝



START

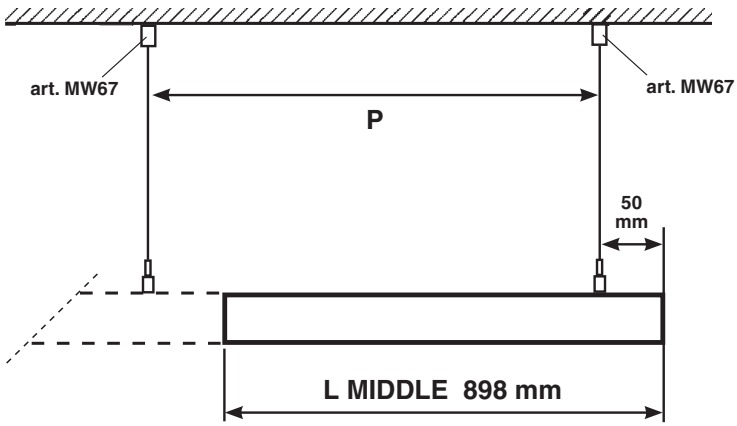

	L START (mm)	P (mm)
2 x 	612	512
	1208	1108
	2397	2297
	3596	3496

MIDDLE/END



	L MIDDLE (mm)	P (mm)
1 x 	898	898
2 x 	3596	1798

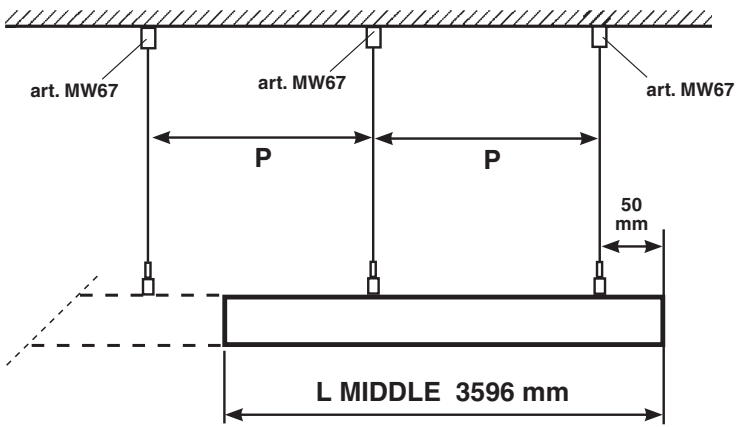

90°

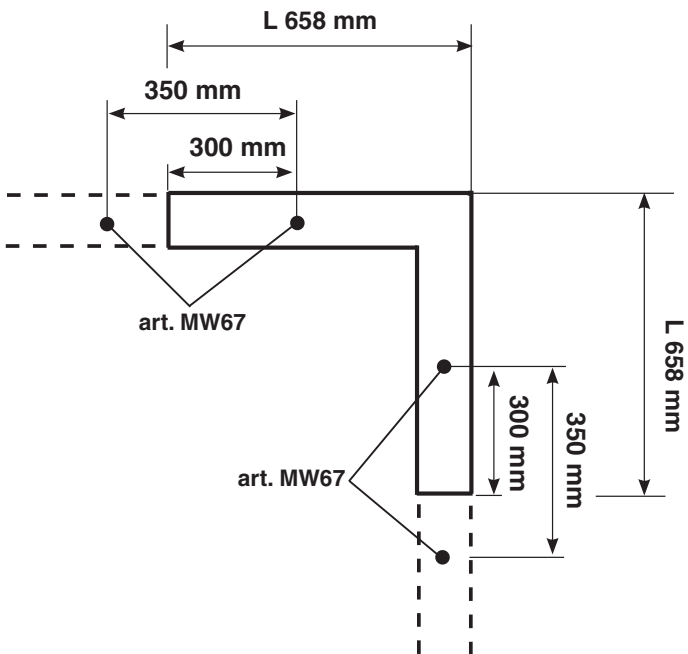

	L (mm)
2 x 	658 x 658

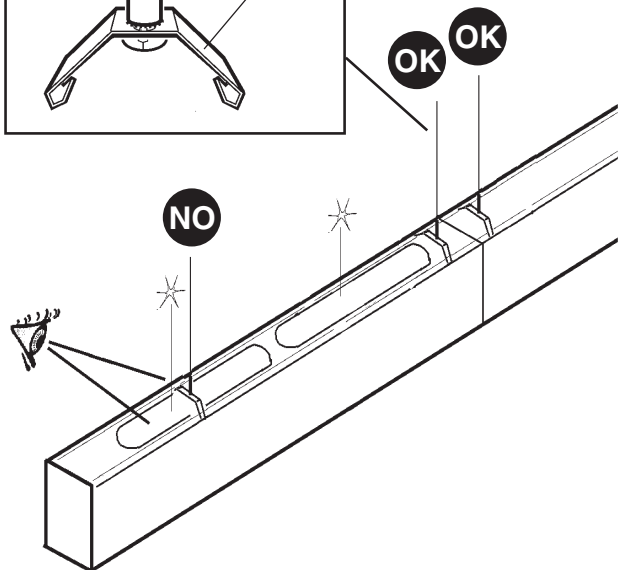
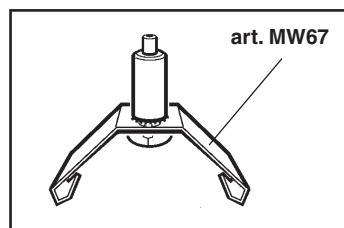
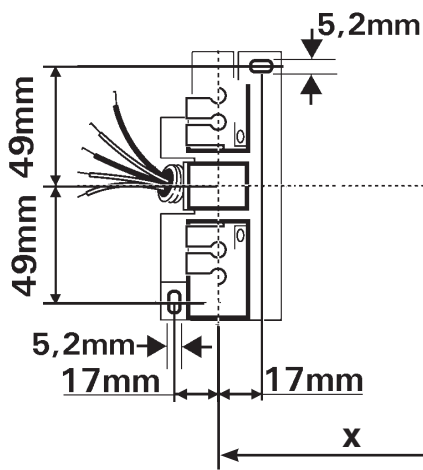
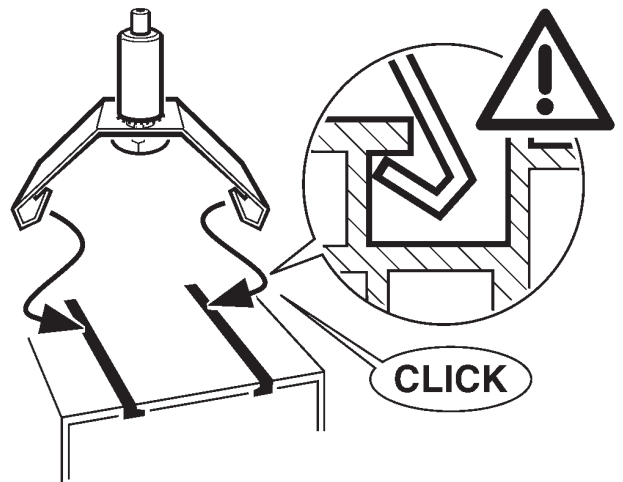
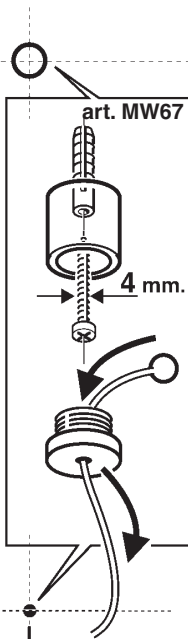
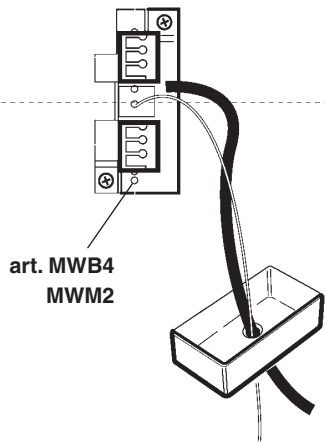
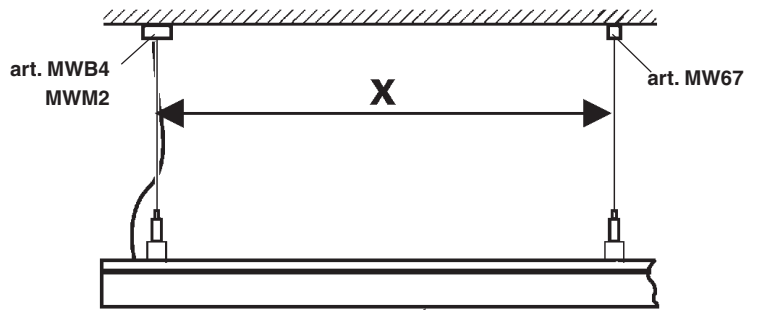
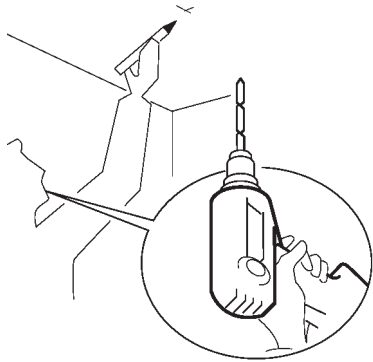

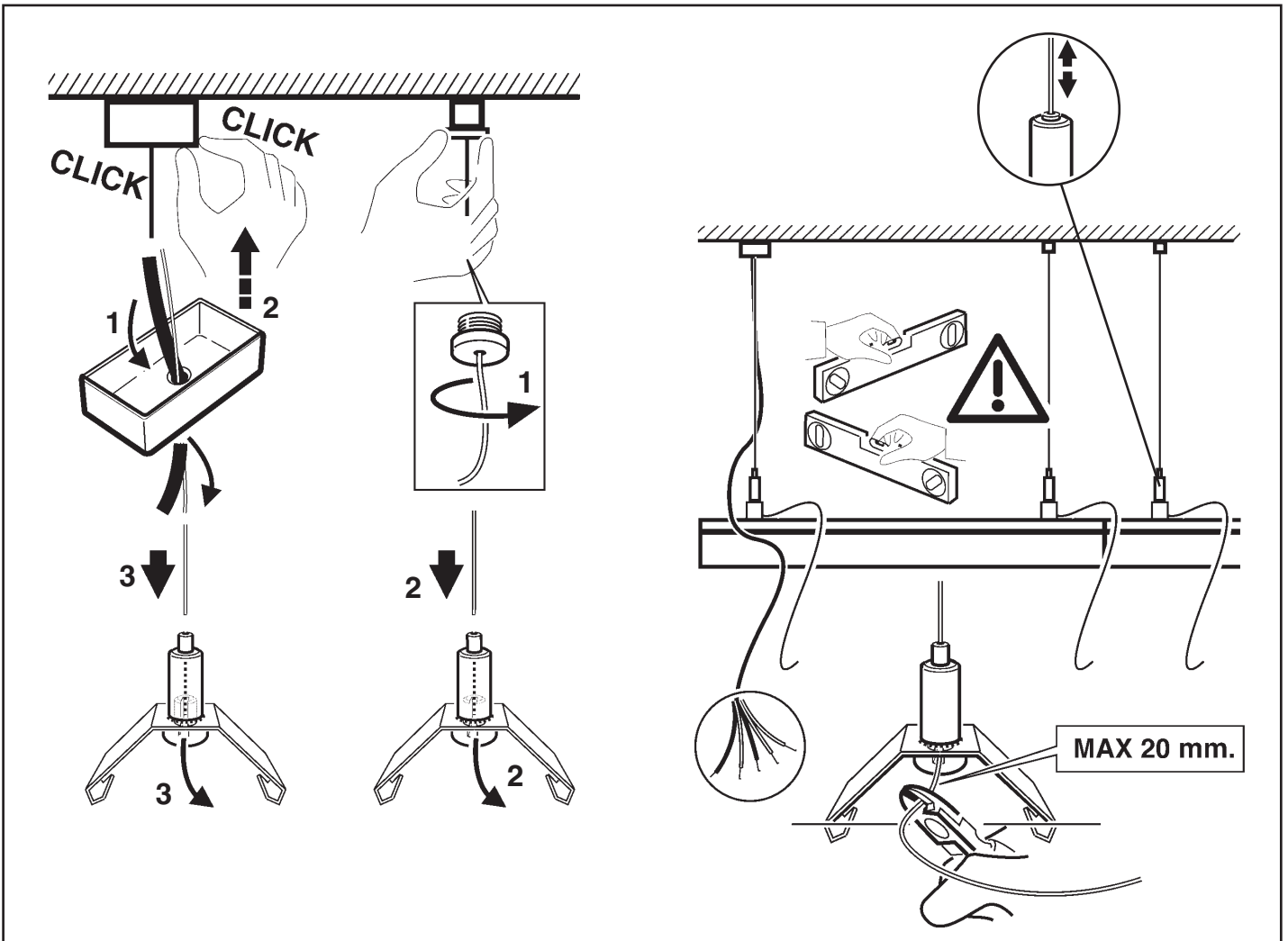
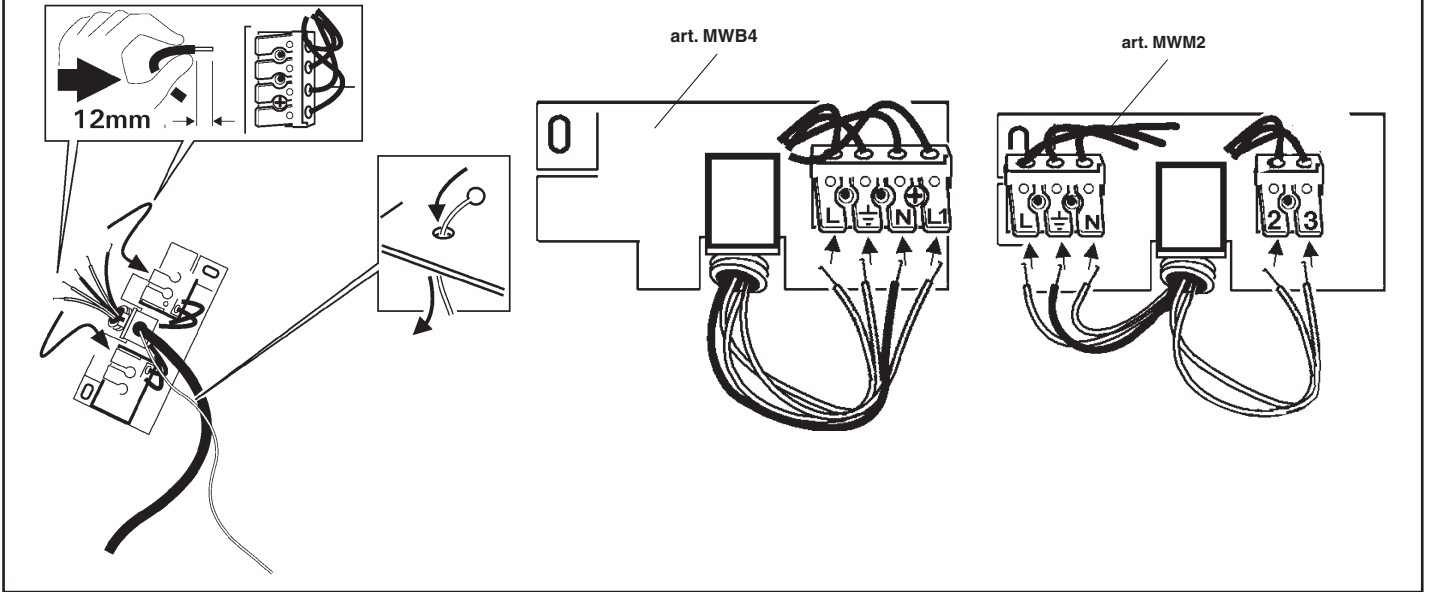

iGuzzini 2.510.113.00 IS11381/00	corrente assorbita absorbed current courant absorbé Stromaufnahme stroomopname corriente absorbida absorberet strøm absorbert strøm tillförd ström поглощаемая мощность 电源电流	fattore di potenza power factor facteur de puissance Leistungsfaktor vermogensfactor factor de potencia effektfaktor effektfaktor effektfaktor фактор мощности 功率因数
	ART.	A
Q388 - Q390 - Q392 - Q394	0,169	>0,95
Q389 - Q391 - Q393 - Q395	0,17	>0,95
Q404 - Q410	0,088	>0,95
Q405 - Q411	0,129	>0,95
Q406 - Q412	0,169	>0,95
Q407 - Q413	0,091	>0,95
Q408 - Q414	0,132	>0,95
Q409 - Q415	0,179	>0,95
Q416 - Q418	0,269	>0,95
Q417 - Q419	0,257	>0,95
Q436 - Q438 - Q440 - Q442	0,073	>0,95
Q437 - Q439 - Q441 - Q443	0,075	>0,95
Q444 - Q450	0,042	>0,9
Q445 - Q451	0,056	>0,9
Q446 - Q452	0,073	>0,95
Q447 - Q453	0,045	>0,9
Q448 - Q454	0,06	>0,9
Q449 - Q455	0,075	>0,95
Q456 - Q458	0,104	>0,95
Q457 - Q459	0,108	>0,95

iGuzzini 2.510.113.00 IS11381/00	corrente assorbita absorbed current courant absorbé Stromaufnahme stroomopname corriente absorbida absorberet strøm absorbert strøm tillförd ström поглощаемая мощность 电源电流	fattore di potenza power factor facteur de puissance Leistungsfaktor vermogensfactor factor de potencia effektfaktor effektfaktor effektfaktor фактор мощности 功率因数
	ART.	A
Q388 - Q390 - Q392 - Q394	0,169	>0,95
Q389 - Q391 - Q393 - Q395	0,17	>0,95
Q404 - Q410	0,088	>0,95
Q405 - Q411	0,129	>0,95
Q406 - Q412	0,169	>0,95
Q407 - Q413	0,091	>0,95
Q408 - Q414	0,132	>0,95
Q409 - Q415	0,179	>0,95
Q416 - Q418	0,269	>0,95
Q417 - Q419	0,257	>0,95
Q436 - Q438 - Q440 - Q442	0,073	>0,95
Q437 - Q439 - Q441 - Q443	0,075	>0,95
Q444 - Q450	0,042	>0,9
Q445 - Q451	0,056	>0,9
Q446 - Q452	0,073	>0,95
Q447 - Q453	0,045	>0,9
Q448 - Q454	0,06	>0,9
Q449 - Q455	0,075	>0,95
Q456 - Q458	0,104	>0,95
Q457 - Q459	0,108	>0,95

iGuzzini 2.510.113.00 IS11381/00	corrente assorbita absorbed current courant absorbé Stromaufnahme stroomopname corriente absorbida absorberet strøm absorbert strøm tillförd ström поглощаемая мощность 电源电流	fattore di potenza power factor facteur de puissance Leistungsfaktor vermogensfactor factor de potencia effektfaktor effektfaktor effektfaktor фактор мощности 功率因数
	ART.	A
Q388 - Q390 - Q392 - Q394	0,169	>0,95
Q389 - Q391 - Q393 - Q395	0,17	>0,95
Q404 - Q410	0,088	>0,95
Q405 - Q411	0,129	>0,95
Q406 - Q412	0,169	>0,95
Q407 - Q413	0,091	>0,95
Q408 - Q414	0,132	>0,95
Q409 - Q415	0,179	>0,95
Q416 - Q418	0,269	>0,95
Q417 - Q419	0,257	>0,95
Q436 - Q438 - Q440 - Q442	0,073	>0,95
Q437 - Q439 - Q441 - Q443	0,075	>0,95
Q444 - Q450	0,042	>0,9
Q445 - Q451	0,056	>0,9
Q446 - Q452	0,073	>0,95
Q447 - Q453	0,045	>0,9
Q448 - Q454	0,06	>0,9
Q449 - Q455	0,075	>0,95
Q456 - Q458	0,104	>0,95
Q457 - Q459	0,108	>0,95

iGuzzini 2.510.113.00 IS11381/00	corrente assorbita absorbed current courant absorbé Stromaufnahme stroomopname corriente absorbida absorberet strøm absorbert strøm tillförd ström поглощаемая мощность 电源电流	fattore di potenza power factor facteur de puissance Leistungsfaktor vermogensfactor factor de potencia effektfaktor effektfaktor effektfaktor фактор мощности 功率因数
	ART.	A
Q388 - Q390 - Q392 - Q394	0,169	>0,95
Q389 - Q391 - Q393 - Q395	0,17	>0,95
Q404 - Q410	0,088	>0,95
Q405 - Q411	0,129	>0,95
Q406 - Q412	0,169	>0,95
Q407 - Q413	0,091	>0,95
Q408 - Q414	0,132	>0,95
Q409 - Q415	0,179	>0,95
Q416 - Q418	0,269	>0,95
Q417 - Q419	0,257	>0,95
Q436 - Q438 - Q440 - Q442	0,073	>0,95
Q437 - Q439 - Q441 - Q443	0,075	>0,95
Q444 - Q450	0,042	>0,9
Q445 - Q451	0,056	>0,9
Q446 - Q452	0,073	>0,95
Q447 - Q453	0,045	>0,9
Q448 - Q454	0,06	>0,9
Q449 - Q455	0,075	>0,95
Q456 - Q458	0,104	>0,95
Q457 - Q459	0,108	>0,95

- I Istruzioni per le operazioni di servizio per l'apparecchio di illuminazione**
GB Instructions on luminaire service operations
F Instructions pour les opérations de service du luminaire
D Wartungsanleitung für die Leuchte
NL Instructies voor de onderhoudsoperaties op de verlichtingsarmatuur
E Instrucciones para las operaciones de servicio del aparato de alumbrado
DK Anvisninger i serviceindgreb på belysningsarmatur
N Anvisninger for betjening av lysapparatet
S Instruktioner för användning av belysningsanordningen
RUS Инструкция по эксплуатации осветительного прибора
CN 照明装置检修操作说明

Sostituire la lampada parzialmente esausta
 Replace the partly exhausted lamp
 Remplacer la lampe partiellement épuisée
 Die teilweise erschöpfte Lampe austauschen
 Vervang de gedeeltelijk lege lamp
 Sustituir la lámpara parzialmente agotada
 Udskift den delvist udtjente pære
 Skifte ut den delvis utbrente lyspæren
 Byt ut den delvis förbrukade lampan
 Замена частично отработавшей лампочки
 更换部分老化的灯泡

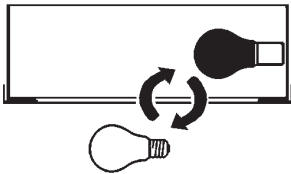

Spegnimento
 Switch it off
 Extinction
 Ausschaltung
 Uitschakeling
 Apagado
 Slukning
 Slukking
 Släckning
 Выключение
 关灯

Interrompere l'alimentazione dell'apparecchio
 Cut the power supply to the luminaire
 Couper l'alimentation du luminaire
 Stromversorgung der Leuchte unterbrechen
 Onderbreek de voeding van het apparaat
 Interrumpir la alimentación del aparato
 Afbryd armaturets strømforsyning
 Avbryt strømtilførselen til apparatet
 Koppla från anordningens strömförsörjning
 Отключить электропитание прибора
 中断装置供电

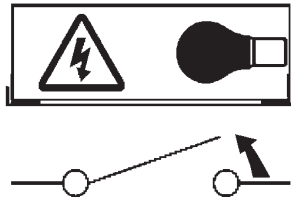

Aprire l'apparecchio
 Open the fixture
 Ouvrir le luminaire
 Das Gerät öffnen
 Open het apparaat
 Abrir el aparato
 Åbn armaturet
 Åpne apparatet
 Öppna anordningen
 Раскрыть прибор
 打开装置

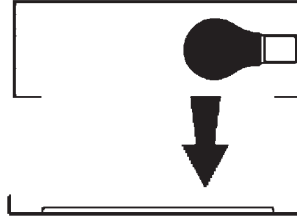

Rimuovere la lampada esausta
 Remove the exhausted lamp
 Retirer la lampe épuisée
 Die alte Lampe entnehmen
 Verwijder de lege lamp
 Quitar la lámpara agotada
 Tag den udtjente pære ud
 Fjerne den utbrente lyspæren
 Ta bort den förbrukade lampan
 Вынуть старую лампочку
 取出老化的灯泡

Portarla in un centro di riciclaggio
 Carry it to a recycling centre
 La porter dans une déchetterie pour son recyclage
 Ordnungsgemäß entsorgen
 Breng de lamp naar een recyclingcentrum
 Llevarla a un centro de reciclaje
 Aflever den på en genbrugsstation
 Lever den til en miljøstasjon
 Lämna in den till en återvinningsanläggning
 Сдать ее в пункт приема утильсырья
 将其送往回收中心

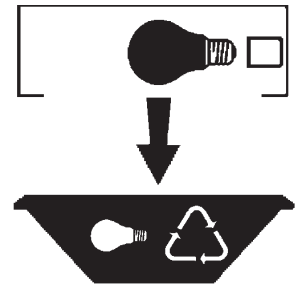

Inserire la nuova lampada
 Introduce the new lamp
 Installer la lampe neuve
 Die neue Lampe einsetzen
 Doe de nieuwe lamp op zijn plek
 Montar la nueva lámpara
 Sæt den nye pære i
 Sette i den nye pæren
 Sätt i den nya lampan
 Вставить новую лампочку
 装入新灯泡

Inserire la nuova lampada nel portalampada
 Fit the new lamp into the socket
 Installer la nouvelle lampe dans le support de lampe
 Die neue Lampe in den Sockel einsetzen
 Doe de nieuwe lamp in de lamphouder
 Montar la nueva lámpara en el portalámpara
 Sæt den nye pære i fatningen
 Sette den nye pæren inn i lampeholderen
 Sätt i den nya lampan i lamphållaren
 Вставить новую лампочку в патрон
 将新灯泡插入灯泡架中



Riposizionare ottica
 Re-place the optic
 Remettre l'optique à sa place
 Die Optik wieder einsetzen
 Doe de optiek weer op zijn plaats
 Volver a montar la óptica
 Sæt den optiske enhed på plads
 Innstille linsen
 Flytta om optiken
 Отрегулировать линзы
 重新定位光头

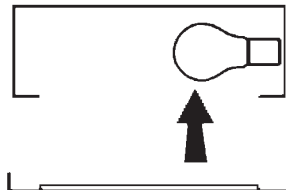

Effettuare prova di funzionamento
 Perform operative test
 Procéder à un essai de fonctionnement
 Eine Funktionsprüfung durchführen
 Controleer de correcte werking
 Hacer una prueba de funcionamiento
 Afprøv funktionen
 Prøve om den fungerer
 Utför funktionstest
 Выполнить проверку исправности работы
 执行功能测试

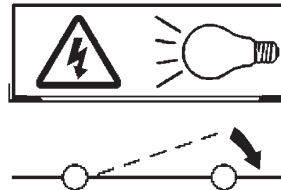

I Istruzioni per la pulizia dell'apparecchio di illuminazione
GB Instructions on luminaire cleaning operations
F Instructions pour le nettoyage du luminaire
D Anweisungen zur Reinigung der Leuchte
NL Instructies voor de reiniging van de verlichtingsarmatuur
E Instrucciones para limpiar el aparato de alumbrado
DK Anvisninger i rengøring af belysningsarmaturet
N Anvisninger for rengjøring av lysapparatet
S Instruktioner för rengöring av belysningsanordningen
RUS Инструкции по чистке осветительного прибора
CN 照明装置清洁说明

Pulire l'apparecchio
Clean the fixture
Nettoyer le luminaire
Das Gerät reinigen
Reinig het apparaat
Limpiar el aparato
Rengør armaturet
Rengjøre apparatet
Rengör anordningen
Чистка прибора
清洁装置

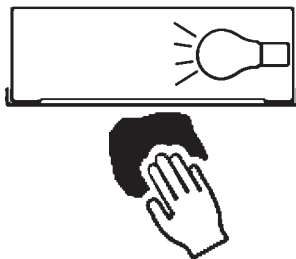

Spegnimento
Switch it off
Extinction
Ausschaltung
Uitschakeling
Apagado
Slukning
Slukking
Släckning
Выключение
关灯

Interrompere l'alimentazione dell'apparecchio
Cut the power supply to the luminaire
Couper l'alimentation du luminaire
Stromversorgung der Leuchte unterbrechen
Onderbreek de voeding van het apparaat
Interrumpir la alimentación del aparato
Afbryd armaturets strømforstyrning
Avbryt strømtilførselen til apparatet
Koppla från anordningens strömförsörjning
Отключить электропитание прибора
中断装置供电



Spolverare l'ottica esterna
Remove dust from the external optic
Dépoussiérer l'optique extérieure
Die externe Optik abstauben
Stof de externe optiek af
Quitar el polvo de la óptica exterior
Tør støvet af den udvendige optiske enhed
Fjerne støv fra den eksterne lysenheten
Damma av den yttre optiken
Вытереть пыль с внешней стороны линз
为外侧光头掸尘



Lavare l'ottica esterna
Wash the external optic
Laver l'optique extérieure
Die externe Optik waschen
Was de externe optiek
Lavar la óptica exterior
Vask den udvendige optiske enhed
Vaske den eksterne lysenheten
Rengör den yttre optiken
Вымыть линзы с внешней стороны
清洁外光头



Rimuovere l'ottica
Remove the optic
Retirer l'optique
Die Optik abnehmen
Verwijder de optiek
Quitar la óptica
Tag den optiske enhed af
Fjerne lysenheten
Ta bort optiken
Снять линзы
取下光头

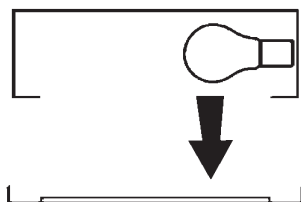

Pulire la parte interna dell'apparecchio di illuminazione
Clean the inside of the fixture
Nettoyer l'intérieur du luminaire
Die Innenseite der Leuchte reinigen
Reinig de binnenzijde van de verlichtingsarmatuur
Limpiar el interior del aparato de alumbrado
Rengør belysningsarmaturets indvendige dele
Rengjøre lysapparatet innvendig
Rengör belysningsanordningen invändigt
Протереть осветительный прибор изнутри
清洁照明装置内部



Riposizionare ottica
Re-place the optic
Remettre l'optique à sa place
Die Optik wieder einsetzen
Doe de optiek weer op zijn plaats
Volver a montar la óptica
Sæt den optiske enhed på plads
Innstille linsen
Flytta om optiken
Отрегулировать линзы
重新定位光头



Effettuare prova di funzionamento
Perform operative test
Procéder à un essai de fonctionnement
Eine Funktionsprüfung durchführen
Controleer de correcte werking
Hacer una prueba de funcionamiento
Afprøv funktionen
Prøve om den fungerer
Utför funktionstest
Выполнить проверку исправности работы
执行功能测试

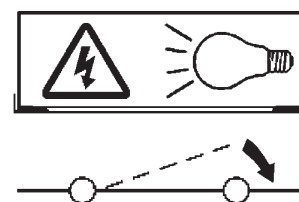

- I** Istruzioni per il fine vita e lo smaltimento dei componenti
GB Instructions on end-of-life and component disposal
F Instructions pour la gestion des composants en fin de vie et leur mise au rebut
D Anweisungen zur Entsorgung der Leuchtenkomponenten
NL Instructies voor het verwijderen van de armatuur en het recyclen van de onderdelen
E Instrucciones para el final de vida y la eliminación los componentes
DK Anvisninger i udtjent armatur og bortskaffelse af komponenter
N Anvisninger for endt levetid og avfallsbehandling av delene
S Instruktioner vid bortskaffning och kassering av komponenter
RUS Инструкции по утилизации прибора и его комплектующих по окончании его срока службы
CN 寿命期结束与零件废弃处置说明

<p>Spegnimento Switch it off Extinction Ausschaltung Uitschakeling Apagado Slukning Slukking Släckning Выключение 关灯</p> <p>Interrompere l'alimentazione dell'apparecchio Cut the power supply to the luminaire Couper l'alimentation du luminaire Stromversorgung der Leuchte unterbrechen Onderbreek de voeding van het apparaat Interrompirla alimentación del aparato Afbryd armaturets strømforsyning Avbryt strømtilførselen til apparatet Koppla från anordningens strömförsörjning Отключить электропитание прибора 中断装置供电</p> 	<p>Rimuovere la/e lampada/e per la dismissione Remove the lamp(s) for decommissioning Retirer la(les) lampe(s) pour sa(leur) mise au rebut Die Lampe/n ordnungsgemäß entsorgen Verwijder de lamp(en) voor het recyclen Quitar la(s) lámpara(s) para el desecho Tag pæren/pærerne ud til bortskaffelse Fjerne lampen/-e som skal kastes Ta bort lampan/-orna för bortskaffningen Вынуть лампочку/и для утилизации прибора 取出需要丢弃的灯泡</p> 	<p>Rimuovere la batteria per la dismissione Remove the battery for decommissioning Retirer la batterie pour sa mise au rebut Die Batterie ordnungsgemäß entsorgen Verwijder de batterij voor het recyclen Quitar la batería para el desecho Tag batteriet ud til bortskaffelse Fjerne batteriet som skal kastes Ta bort batteriet för bortskaffningen Вынуть батарейку для утилизации прибора 取出需要丢弃的电池</p> 	<p>Rimuovere l'apparecchio per la dismissione Remove the fixture for decommissioning Enlever le luminaire pour sa mise au rebut Das Gerät ordnungsgemäß entsorgen Verwijder het apparaat voor het recyclen Quitar el aparato para el desecho Tag armaturet ud til bortskaffelse Fjerne apparatet som skal kastes Ta bort anordningen för bortskaffningen Снять прибор для утилизации 取出需要丢弃的装置</p> 
---	--	--	--

<p>Inviare i materiali ad un centro di raccolta RAEE Send the materials to a WEEE collection centre Envoyer les matériaux dans une déchetterie DEEE Die Materialien in einem WEEE-Zentrum entsorgen Zend de materialen naar een recyclingscentrum voor de AEEA Enviar los materiales a un centro de recogida RAEE Afløver materialerne på et indsamlingscenter for elektronisk udstyr Sende materialene til en miljøstasjon for resirkulering av EE-avfall Skicka materialet till en RAEE uppsamlingscentral Сдать материалы в пункт приема утильсырья 将材料送往电气和电子垃圾回收中心</p> 			
--	--	--	--