

## iPRO PLAFONE

### ATTENZIONE:

LA SICUREZZA DELL'APPARECCHIO E' GARANTITA SOLO CON L'USO APPROPRIATO DELLE SEGUENTI ISTRUZIONI; PERTANTO E' NECESSARIO CONSERVARLE.

### WARNING:

THE SAFETY OF THIS FIXTURE IS GUARANTEED ONLY IF YOU COMPLY WITH THESE INSTRUCTIONS; REMEMBER TO CONSERVE IN A SAFE PLACE.

### ATTENTION:

LA SECURITE DEL'APPAREIL N'EST GARANTIE QU'EN CAS D'UTILISATION CORRECTE DES INSTRUCTIONS SUIVANTES; IL FAUT PAR CONSEQUENT LES CONSERVER.

### ACHTUNG:

DIE SICHERHEIT DES GERÄTES WIRD NUR DURCH SACHGEMÄSSE BEFOLGUNG NACHSTEHENDER ANWEISUNGEN GEWÄHRLEISTET; IHRE AUFBEWAHRUNG IST DESHALB SEHR WICHTIG.

### ATTENTIE:

DE VEILIGHEID VAN DE APPARATUUR IS SLECHTS DAN GEGARANDEERD ALS MEN DE VOLGENDE INSTRUKTIES STRIKT OPVOLGT; DAAROM MOET MEN ZE OOK BEWAREN.

### ATENCION:

LA SEGURIDAD DEL APARATO SE GARANTIZA SOLO CUMPLIENDO CUIDADOSAMENTE LAS SIGUIENTES INSTRUCCIONES; POR ELLO, ES NECESARIO CONSERVARLAS.

### BEMÆRK:

SIKKERHEDEN VED BRUG AF ARMATURET KAN KUN GARANTERES, HVIS DISSE ANVISNINGER FØLGES; SØRG DERFOR FOR AT GEMME DEM.

### ADVARSEL:

SIKKERHETEN TIL DETTE APPARATET GARANTERES KUN HVIS DU OVERHOLDER DISSE INSTRUKSJONENE; HUSK Å OPPBEVARE DEM PÅ ET TRYGT STED.

### OBSERVERA!

UTRUSTNINGENS SÄKERHET KAN ENDAST GARANTERAS OM DESSA ANVISNINGAR RESPEKTERAS I DETALJ. SPARA DÄRFÖR DESSA ANVISNINGAR FÖR FRAMTIDA KONSULTATION.

### ВНИМАНИЕ:

МЫ ГАРАНТИРУЕМ БЕЗОПАСНУЮ ЭКСПЛУАТАЦИЮ ИЗДЕЛИЯ ТОЛЬКО ПРИ СОБЛЮДЕНИИ СЛЕДУЮЩИХ ИНСТРУКЦИЙ; С ЭТОЙ ЦЕЛЬЮ НЕОБХОДИМО СОХРАНИТЬ ДАННУЮ БРОШЮРУ.

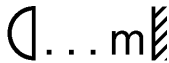
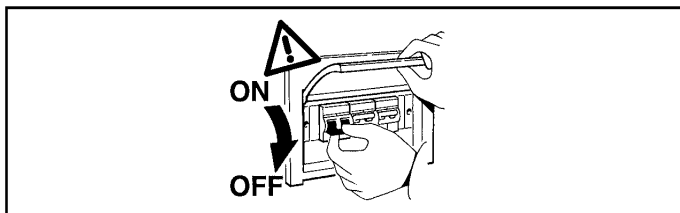

### 警告:

为确保该装置安全, 请遵守操作指示, 并于安全场所放置。

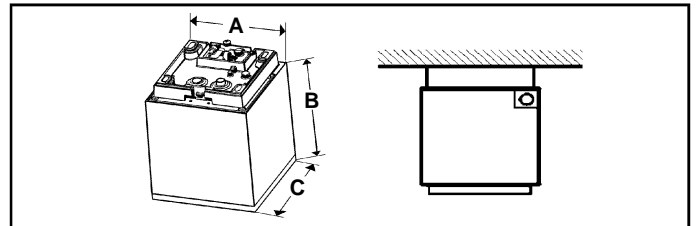

- I Rispettare la distanza minima dall'oggetto illuminato, misurata lungo l'asse ottico della lampada.
- GB Respect the minimum distance from the illuminated object, measured along the optical axis of the lamp.
- F Respectez la distance minimum de l'objet éclairé, mesurée le long de l'axe optique de la lampe.
- D Halten Sie bitte den längs zur optischen Achse der Leuchte gemessenen Mindestabstand zum beleuchteten Gegenstand ein.
- NL Respecteer de minimum afstand van het verlichte object, gemeten langs de optische as van de lamp.
- E Respetar la distancia mínima respecto del objeto iluminado, medida a lo largo del eje óptico de la lámpara.
- DK Minimumsafstanden til det oplyste objekt skal overholdes, målt langs lyskildens optiske akse.
- N Overhold minsteavstanden fra den opplyste gjenstanden, målt langs den optiske aksene til lampen.
- S Respektera minimiavståndet från det belysta föremålet, uppmätt längs lampans optiska axel.
- RUS Соблюдайте минимальное расстояние от освещенного объекта, измеренное вдоль оптической оси лампы.
- CN 保持照明物体沿光源的光轴测量的最小距离。



ART.	Peso Weight Poids Gewicht Gewicht Peso VÆGT VEKT VIKT BEC 重量 (Kg)	Dimensioni Dimensions Dimensions Abmessungen Afmetingen Dimensiones Mål - Mål - Mått Размеры 尺寸 a x b x c (mm)	Superficie Surface Surface Oberfläche Oppervlak Superficie Overflade Поверхность 面积 
	8,4	192 x 202 x 192	(mq) 0,042
	4,6	155 x 165 x 155	0,026

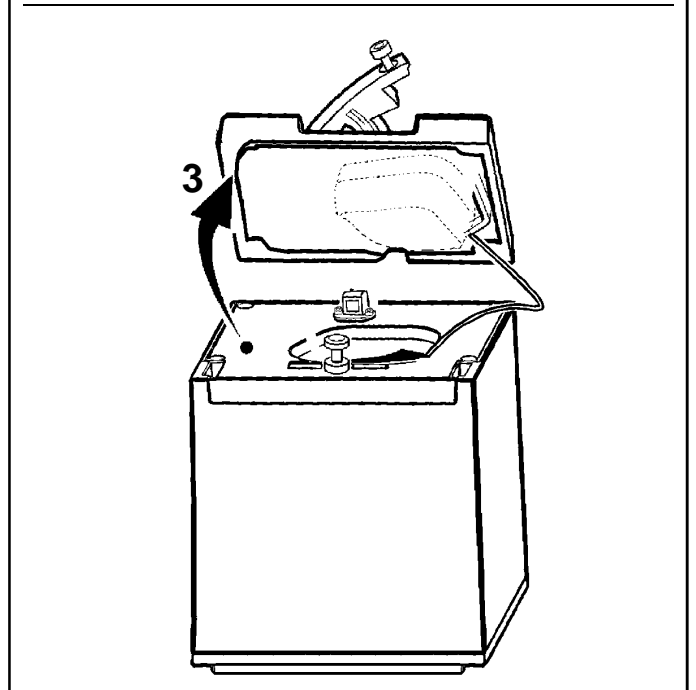
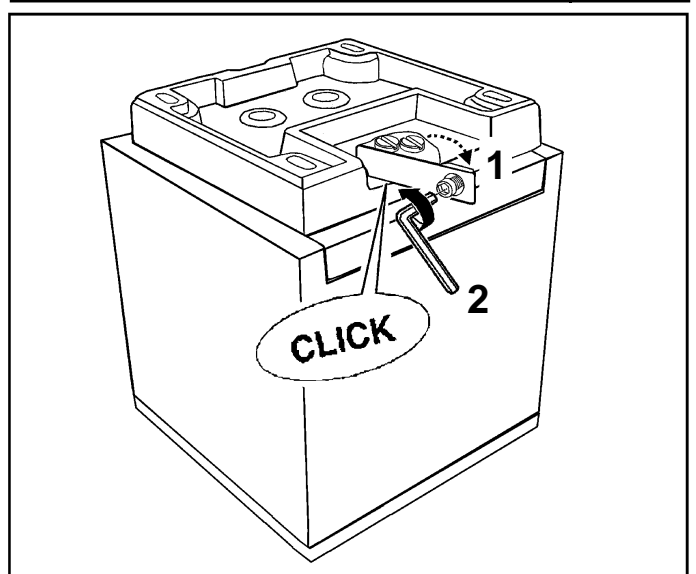

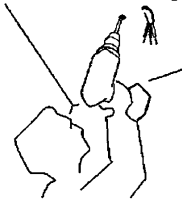
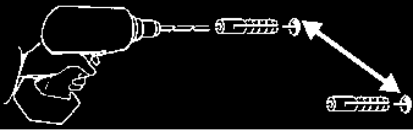

**M**

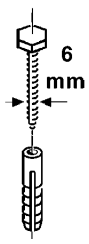
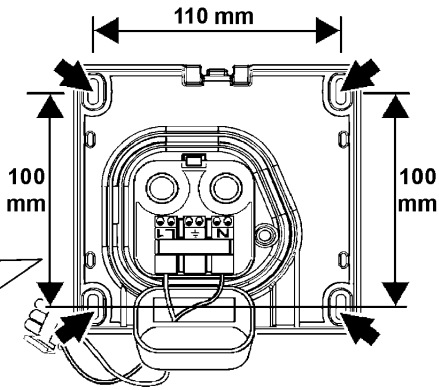

**L**

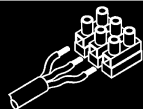
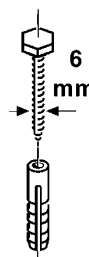
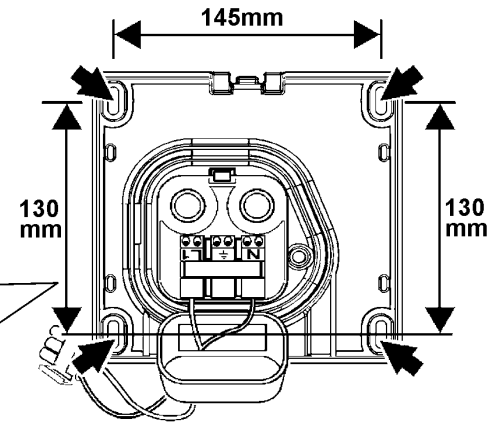

art. BI31 - BI32 - BI33  
BI34 - BI38 - BI39  
BI40 - BL22 - BL23  
BL24 - BL25 - BL26  
BL27

I Per esigenze di collaudo, il prodotto è stato munito dei cavi indicati in figura.  
N.B.: Asportare tali cavi prima di effettuare il cablaggio del prodotto.

GB In order to test the product, it was fitted with the cables indicated in the figure.  
N.B.: Remove these cables before wiring the product.

F Pour des nécessités d'essai, le produit est fourni avec les câbles indiqués dans la figure.  
N.B.: Enlevez ces câbles avant d'effectuer le câblage du produit.

D Aufgrund von Prüfungserfordernissen wurde das Produkt mit den auf der Abbildung ersichtlichen Kabeln bestückt.  
N.B.: Diese Kabel sind vor der Verkabelung des Produkts abzunehmen.

NL Zoals voor de keuring vereist is het product voorzien van de in de afbeelding aangegeven kabels.  
N.B.: Verwijder deze voordat u het product gaat bedraden.

E Debido a exigencias de ensayo, el producto ha sido provisto de los cables indicados en la figura.  
NOTA: Extraer dichos cables antes de realizar el cableo del producto.

DK Med henblik på afprøvning er produktet forsynet med ledningerne, som vist i figuren.  
N.B.: Disse ledninger skal fjernes, inden produktet tilsluttes.

N For å kunne teste produktet, ble dette montert med kablene som indikeres på figuren.  
N.B.: Fjern disse kablene før produktet installeres.

S På grund av provkörnings skull har produkten försetts med kablar som indikeras i figuren.  
OBS! Ta bort dessa kablar innan ledningsdragningen för produkten görs.

RUS Для тестирования прибор оснащен проводами, показанными на схеме.  
ПРИМЕЧАНИЕ: Отсоедините эти провода перед монтажом кабелепроводки при бора.

CN 为检测产品，产品配备了图中所示的电缆。  
注意：为产品配线前，拆掉这些电缆。

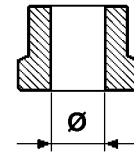
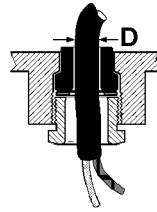
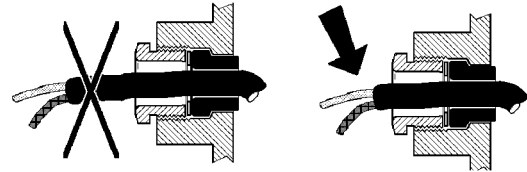

D ( mm )	Ø ( mm )
8,5 ÷ 11	10
10,5 ÷ 12,5	12

art. BI31 - BI32 - BI33  
BI34 - BI35 - BI36  
BI37 - BI38 - BI39  
BI40 - BL22 - BL23  
BL24 - BL25 - BL26  
BL27

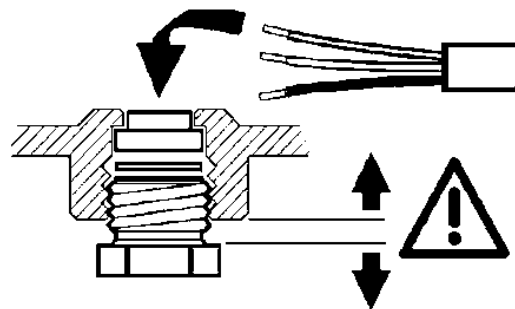
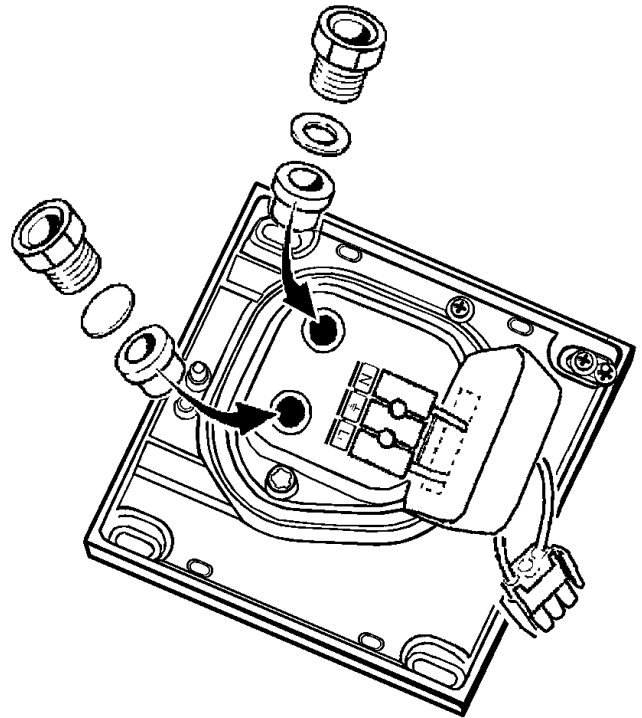

art. BL27

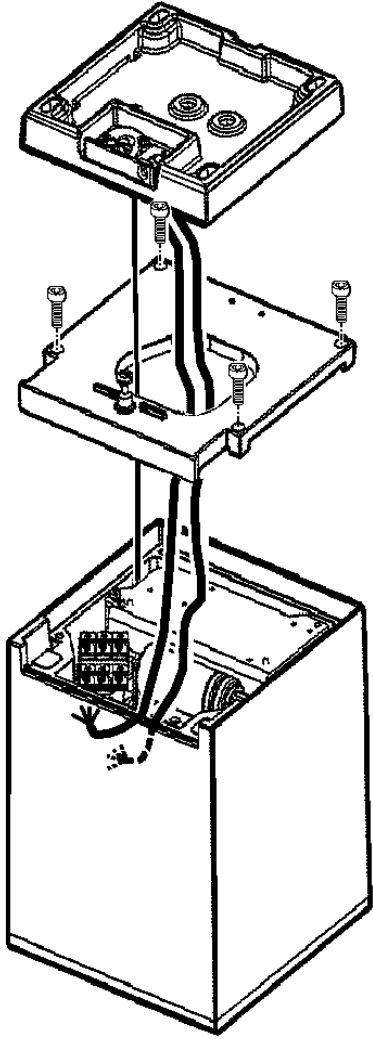

ART.	A mm	B mm	C mm
art. BI35 - BI36 - BI37			9 ÷ 10
art. BI31 - BI32 - BI33 BI34 - BI38 - BI39 BI40 - BL22 - BL23 BL24 - BL25 - BL26	3 ÷ 4	50	10 ÷ 11
art. BL27		300	

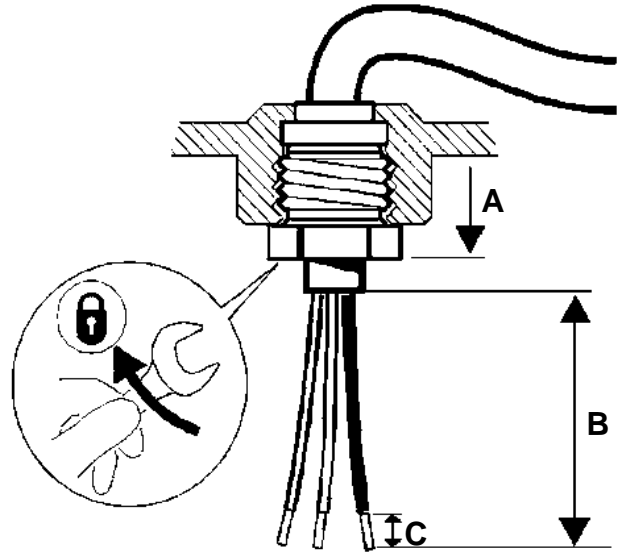

art. BI31 - BI32 - BI33  
BI34 - BI35 - BI36  
BI37 - BI38 - BI39  
BI40 - BL22 - BL23  
BL24 - BL25 - BL26

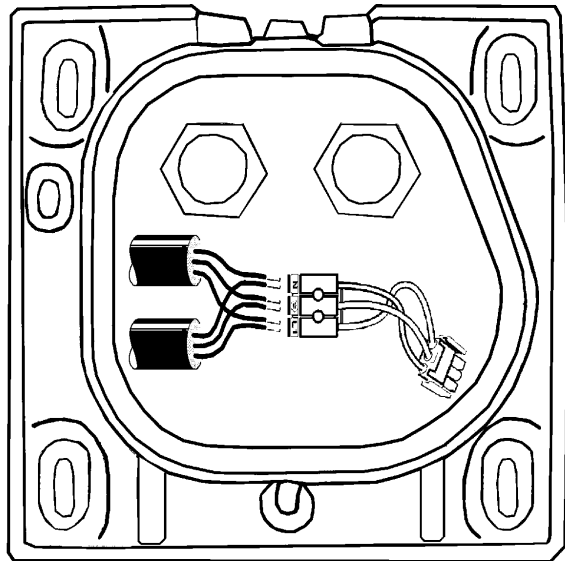
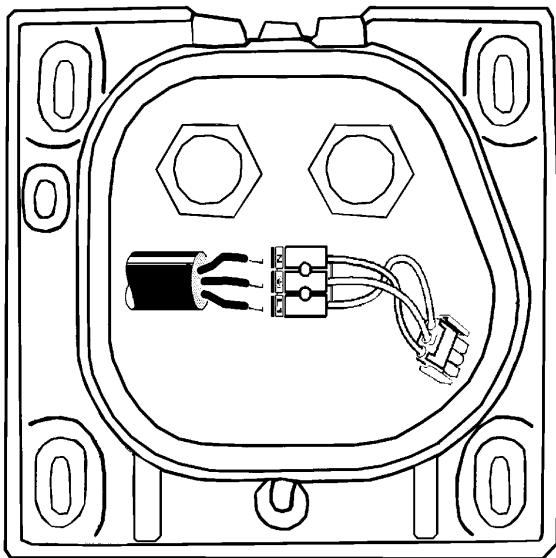

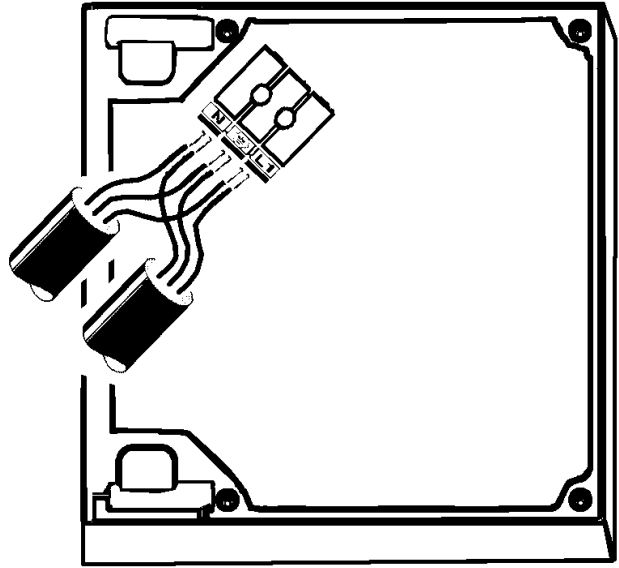
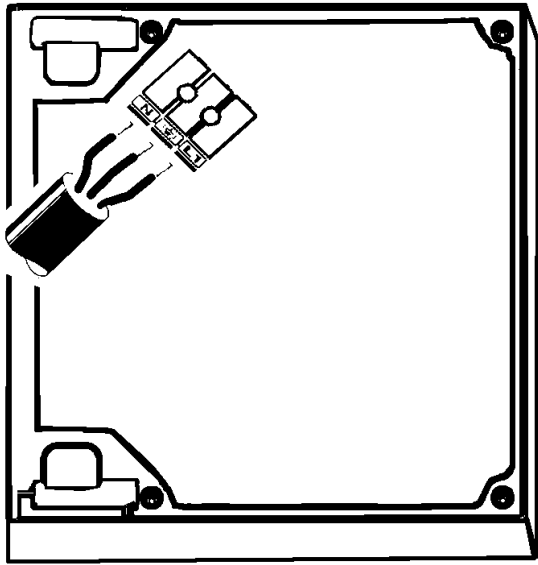

art. BI31 - BI32 - BI33  
BI34 - BI35 - BI36  
BI37 - BI38 - BI39  
BI40 - BL22 - BL23  
BL24 - BL25 - BL26  
BL27

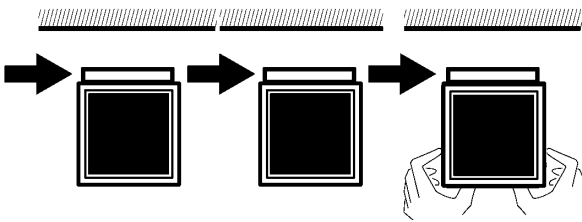

2,5 mm<sup>2</sup>

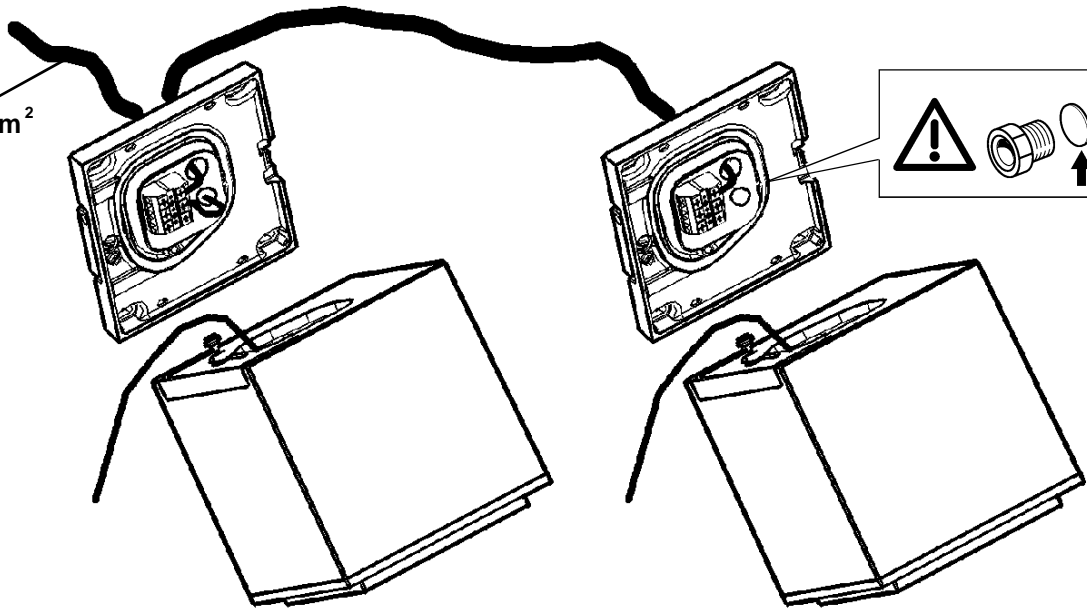

art. BI31 - BI32 - BI33  
 BI34 - BI35 - BI36  
 BI37 - BI38 - BI39  
 BI40 - BL22 - BL23  
 BL24 - BL25 - BL26  
 BL27

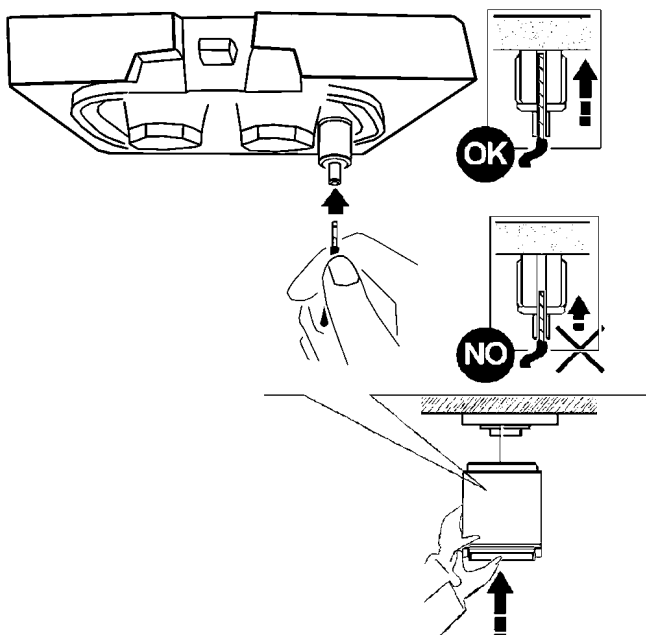

art. BI31 - BI32 - BI33  
 BI34 - BI35 - BI36  
 BI37 - BI38 - BI39  
 BI40 - BL22 - BL23  
 BL24 - BL25 - BL26

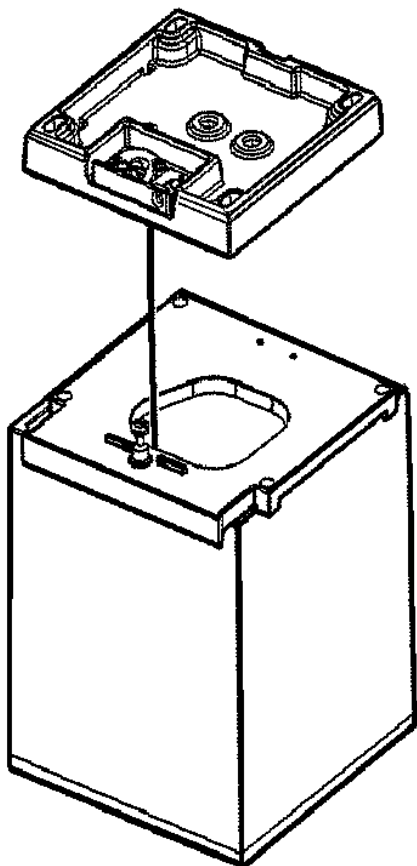

art. BI31 - BI32 - BI33  
 BI34 - BI35 - BI36  
 BI37 - BI38 - BI39  
 BI40 - BL22 - BL23  
 BL24 - BL25 - BL26

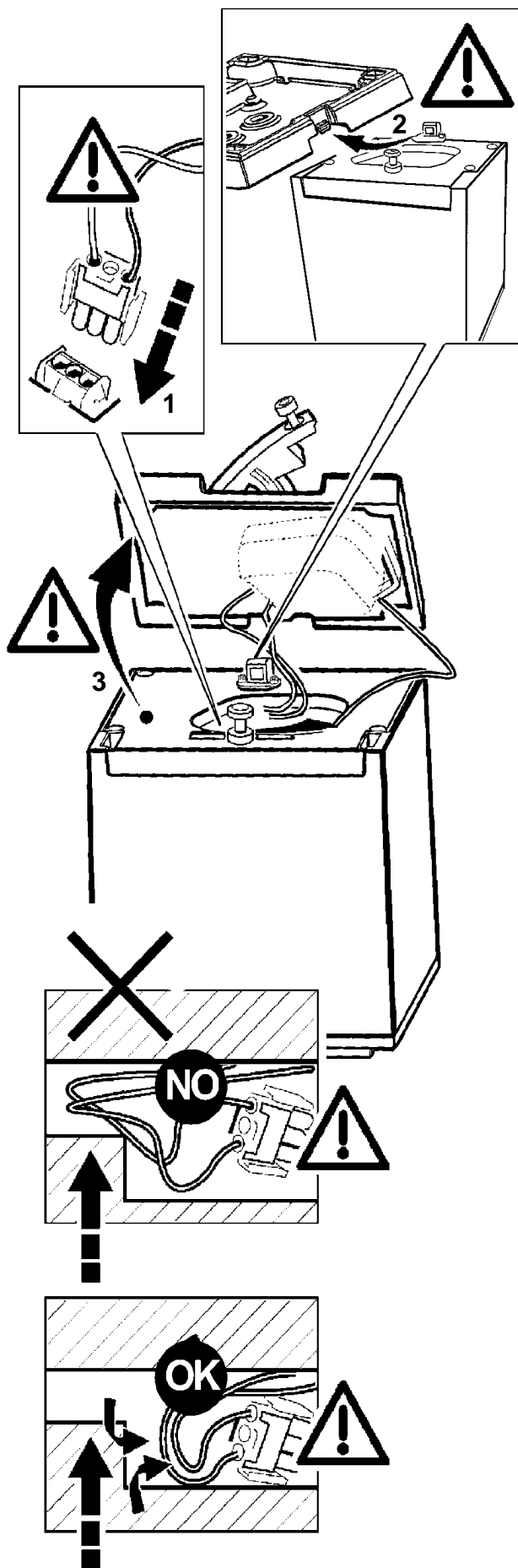

art. BL27

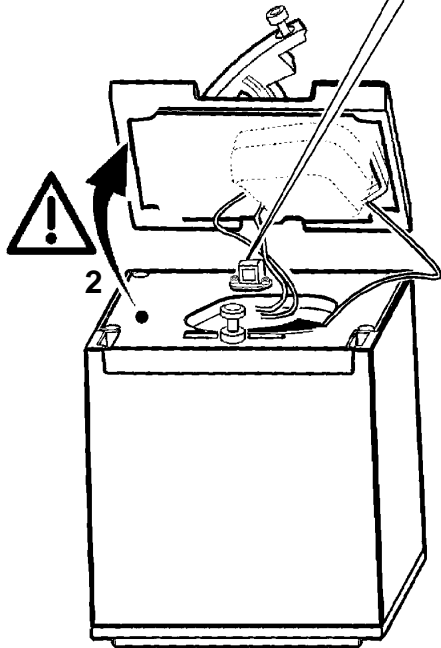
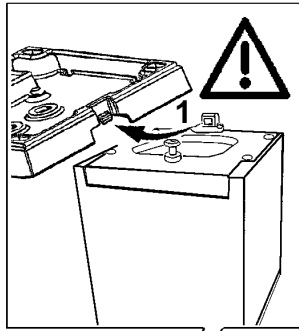

art. BI31 - BI32 - BI33  
BI34 - BI35 - BI36  
BI37 - BI38 - BI39  
BI40 - BL22 - BL23  
BL24 - BL25 - BL26  
BL27

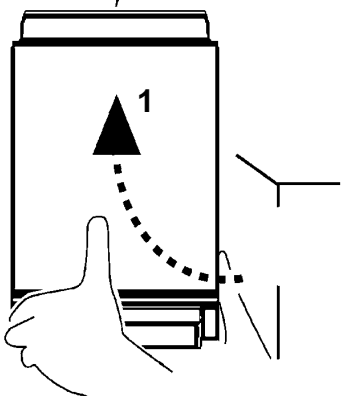
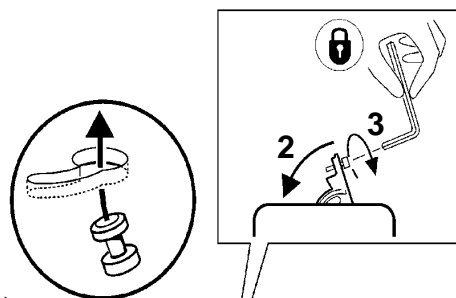

I Nella progettazione dell'impianto illuminotecnico ed elettrico, determinare le correnti massime ammissibili, considerando i seguenti fattori:

- 16A: corrente nominale ammessa dalle morsettiere (BI35);
- 20A: corrente nominale ammessa dalle morsettiere (BI31 - BI32 - BI33 - BI34 - BI38 - BI39 - BI40 - BL22 - BL23 - BL24 - BL25 - BL26 - BL27);
- coefficiente di sicurezza per tenere conto delle sovratensioni e contemporaneità;
- corrente nominale assorbita dai singoli art.

E' buona norma evitare di far lavorare i conduttori dei cavi ai massimi valori.

GB When planning the lighting and electrical system, determine the maximum permitted current, taking into account the following factors:

- 16A: the nominal current permitted by terminal blocks (BI35);
- 20A: the nominal current permitted by terminal blocks (BI31 - BI32 - BI33 - BI34 - BI38 - BI39 - BI40 - BL22 - BL23 - BL24 - BL25 - BL26 - BL27);
- safety coefficient to allow for excess voltage and contemporaneity;
- the nominal current absorbed by single art.

It is recommended that the wires inside the cables are made to operate at the maximum values.

F Lors de l'étude de projet de l'installation d'éclairage et de l'installation électrique, déterminer les courants maximaux admissibles en tenant compte des facteurs suivants :

- 16A: courant maximal admis par les borniers (BI35);
- 20A: courant maximal admis par les borniers (BI31 - BI32 - BI33 - BI34 - BI38 - BI39 - BI40 - BL22 - BL23 - BL24 - BL25 - BL26 - BL27);
- coefficient de sécurité tenant compte des surtensions et de la simultanéité;
- courant nominal absorbé par les différents art.

Il est conseillé de ne pas faire fonctionner les câbles aux valeurs maximales.

D Bei der Planung einer Beleuchtungs- und Elektroanlage bestimmen Sie die zulässigen Höchstströme unter Berücksichtigung folgender Faktoren:

- 16A: von den Klemmleisten zugelassener Nennstrom (BI35);
- 20A: von den Klemmleisten zugelassener Nennstrom (BI31 - BI32 - BI33 - BI34 - BI38 - BI39 - BI40 - BL22 - BL23 - BL24 - BL25 - BL26 - BL27);
- Sicherheitskoeffizient zur Einbeziehung von Überspannung und Gleichzeitigkeit;
- von den einzelnen art. aufgenommener Nennstrom.

Es ist bewährte Praxis, die Leiter der Kabel möglichst nicht den Höchstwerten auszusetzen.

NL Bij het ontwerpen van de verlichtingstechnische en elektrische installatie moet u de maximaal toegestane stroomtoevoer vaststellen door rekening te houden met de volgende factoren:

- 16A: nominale stroom toegestaan op klemmenstroken (BI35);
- 20A: nominale stroom toegestaan op klemmenstroken (BI31 - BI32 - BI33 - BI34 - BI38 - BI39 - BI40 - BL22 - BL23 - BL24 - BL25 - BL26 - BL27);
- veiligheidscoëfficiënt om rekening te houden met overspanning en gelijktijdigheid;
- nominale opgenomen stroom van de enkele Art.

We raden u aan de kabelgeleiders nooit op maximaal vermogen te laten functioneren.

E Durante la proyectación de la instalación luminotécnica y eléctrica, determinar las corrientes máximas permitidas, en consideración de los factores siguientes:

- 16A: corriente nominal permitida de las borneras (BI35);
- 20A: corriente nominal permitida de las borneras (BI31 - BI32 - BI33 - BI34 - BI38 - BI39 - BI40 - BL22 - BL23 - BL24 - BL25 - BL26 - BL27);
- coeficiente de seguridad para considerar sobretensiones y contemporaneidades;
- corriente nominal absorbida por los art. individuales.

Se aconseja evitar que los conductores de cables trabajen con valores máximos.

N I projekteringen af det belysningstekniske og elektriske anlæg, skal man undersøge den maks. tilladte strømstyrke, idet man tager højde for følgende:

- 16A: nominal tilladt strømstyrke fra klemrækkerne (BI35);
- 20A: nominal tilladt strømstyrke fra klemrækkerne (BI31 - BI32 - BI33 - BI34 - BI38 - BI39 - BI40 - BL22 - BL23 - BL24 - BL25 - BL26 - BL27);
- sikkerhedskoefficient for at sikre mod overspænding og samtidighed
- nominal absorberet strømstyrke på de enkelte dele

Man bør undgå at udsætte ledningerne for maks. belastning.

DK Under projektering af det belysningstekniske og elektriske anlæg, må maksimal tilladt strøm beregnes, ved å ta med i betragtningen følgende faktorer:

- 16A: merkestrøm godtaget av klemmebrettene (BI35);
- 20A: merkestrøm godtaget av klemmebrettene (BI31 - BI32 - BI33 - BI34 - BI38 - BI39 - BI40 - BL22 - BL23 - BL24 - BL25 - BL26 - BL27);
- sikkerhedskoefficient for å holde oversikt over overstrøm og samtidig påslåing;
- merkestrøm som opptas av de enkelte modulene.

Det er en god regel å ikke bruke kablenes ledere ved maksimale verdier.

S Vid projekteringen av belysningsssystemet och det elektriska systemet ska max. tillåten ström fastställas. Ta hänsyn till följande faktorer:

- 16A: Tillåten nominell ström från kopplingsplintarna (BI35);
- 20A: Tillåten nominell ström från kopplingsplintarna (BI31 - BI32 - BI33 - BI34 - BI38 - BI39 - BI40 - BL22 - BL23 - BL24 - BL25 - BL26 - BL27);
- Säkerhetskoefficient för att ta hänsyn till överspänningar och sammanlagringar.
- Tillförd nominell ström från enskilda artiklar.

Det rekommenderas att undvika att låta kablabarnas ledare arbeta med maximala värden.

RUS При расчёте светотехнической системы и электропроводки определите максимальный допустимый ток с учётом следующих факторов:

- 16А: номинальный допустимый ток, допустимый в клеммных колодках; (BI35)
- 20А: номинальный допустимый ток, допустимый в клеммных колодках; (BI31 - BI32 - BI33 - BI34 - BI38 - BI39 - BI40 - BL22 - BL23 - BL24 - BL25 - BL26 - BL27)
- коэффициент безопасности для учёта перенапряжения и одновременного включения;
- номинальный ток, поглощаемый отдельными изделиями.

Не следует подвергать провода кабелей рабочему режиму с максимальными значениями.

CN 设计电器、照明设备的时候必须参照下列数据，确定允许的最大电流：

- 16A: 接头允许的额定电流 (BI35)
- 20A: 接头允许的额定电流 (BI31 - BI32 - BI33 - BI34 - BI38 - BI39 - BI40 - BL22 - BL23 - BL24 - BL25 - BL26 - BL27)
- 为监控超电压与同时性的安全系数；
- 每个组件的额定吸收电流。

请避免让电缆的导体在最高数据下运行。



art. BI35 - BI36 - BI37  
BL25 - BL26 - BL27

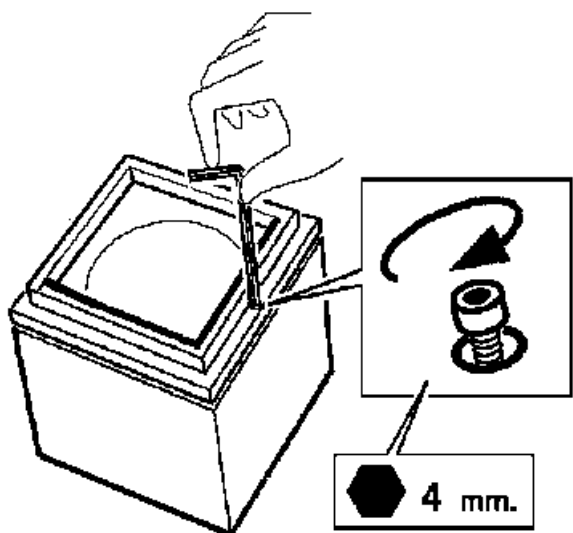
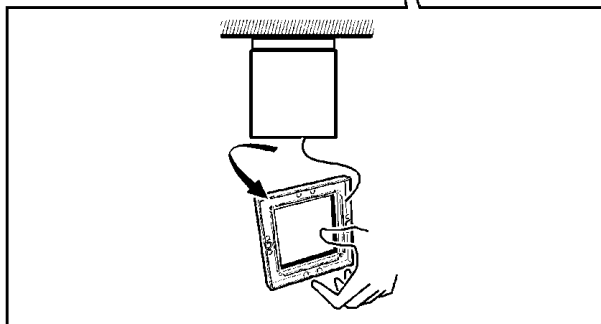
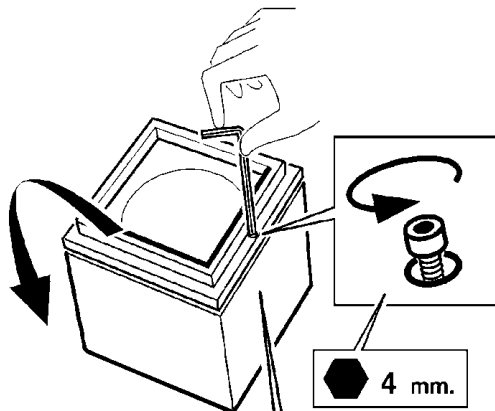

N.B.: DURANTE L'INSTALLAZIONE DEL SISTEMA "iPRO" RISPETTARE SCRUPOLOSAMENTE LE NORME IMPIANTISTICHE VIGENTI.

N.B.: WHEN INSTALLING THE SYSTEM "iPRO", STRICTLY COMPLY WITH ALL REGULATIONS ON INSTALLATION IN FORCE.

N.B.: LORS DE L'INSTALLATION DU SYSTÈME "iPRO" VEUILLEZ RESPECTER RIGOREUSEMENT LES NORMES EN VIGUEUR EN LA MATIÈRE.

NB: BEACHTEN SIE BEI DER INSTALLATION DES SYSTEMS "iPRO" GEWISSENHAFT DIE GÜLTIGEN BESTIMMUNGEN BEZÜGLICH DER ANLAGENTECHNIK.

N.B.: BIJ HET INSTALLEREN VAN HET "iPRO" SYSTEEM MOET U DE GELDENDE INSTALLATIENORMEN STRIKT NALEVEN.

N.B.: DURANTE LA INSTALACIÓN DEL SISTEMA "iPRO" RESPETAR ESCRUPULOSAMENTE LAS NORMAS DE INSTALACIÓN VIGENTES.

N.B.: UNDER INSTALLATION AF "iPRO" SYSTEMET SKAL MAN NØ JE OVERHOLDE DE GÆLDENDE REGLER FOR DISSE ANLÆG.

N.B.: VED INSTALLASJON AV SYSTEMET "iPRO" SKAL ALLE FORSKRIFTER OM INSTALLASJON SOM GJELDER FØLGES STRENGT.

OBS! UNDER INSTALLATIONEN AV SYSTEMET "iPRO" SKA INSTALLATIONSFÖRESKRIFTERNA RESPEKTERAS I DETALJ.

ПРИМЕЧАНИЕ: В ПРОЦЕССЕ МОНТАЖА СИСТЕМЫ "iPRO" СТРОГО СОБЛЮДАЙТЕ НАЦИОНАЛЬНЫЕ ДЕЙСТВУЮЩИЕ НОРМАТИВЫ ПО ЭЛЕКТРОПРОВОДКЕ.

注意: 在安装 "iPRO" 系统时请遵守设备的安装规定。

I N.B.: Per la sostituzione del LED contattare l'azienda iGuzzini.

GB N.B.: For information on LED replacement please contact iGuzzini.

F N.B.: Pour procéder au remplacement de la LED, adressez-vous à la société iGuzzini.

D N.B.: Bezüglich des Austausches der LED kontaktieren Sie bitte die Firma iGuzzini.

NL N.B.: Voor het vervangen van de LED neemt u contact op met het bedrijf iGuzzini.

E NOTA: Para sustituir el LED llame a la empresa iGuzzini.

DK N.B.: For udsifting af den lysemitterende dioden ta kontakt med firmaet iGuzzini.

N N.B.: For udskiftning af lysdioden, skal man kontakte iGuzzini.

S OBS! För byte av lysdioden, kontakta företaget iGuzzini.

RUS ПРИМЕЧАНИЕ: Для замены СИДов обращайтесь в компанию iGuzzini.

CN 注意: 有关发光二极管照明替换信息, 请联系 iGuzzini 公司。

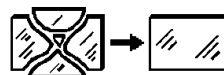

I In caso di rottura del vetro il prodotto non può essere utilizzato, contattare il costruttore per la sua sostituzione.

GB Should the glass break, the product cannot be used and you should contact the manufacturer for its replacement.

F En cas d'endommagement de l'écran de protection le produit ne peut pas être utilisé, contactez le fabricant pour le remplacement.

D Falls das Glas kaputt sein sollte, kann das Produkt nicht verwendet werden. Kontaktieren Sie in dem Fall den Hersteller, um das Glas zu ersetzen.

NL Als het glas gebroken is kan het apparaat niet worden gebruikt en moet u zich tot de fabrikant wenden voor het vervangen van het glas.

E No utilizar el producto en caso de ruptura del vidrio y contactar el fabricante para la sustitución.

DK Hvis produktets glas ødelægges, kan det ikke anvendes. Kontakt forhandleren med henblik på udskiftning.

N Hvis glasset skulle knuses, kan ikke produktet brukes, og du må ta kontakt med produsenten for å få det skiftet.

S Om glaset går sönder kan inte produkten användas. Kontakta tillverkaren för att byta ut glaset.

RUS В случае разбивания стекла не используйте прибор, обратитесь к его производителю для замены. GB

CN 一旦玻璃破碎后产品将不能再使用, 须联系生产商予以更换。

⊕ art.

ART.					
	art. BZ78	art. BZ79	art. BZ78 1154 + art. BZ77	art. BZ79 + art. BZ77	art. BZ78 + art. BZ79 BZ80 + art. BZ77
BI38	X	X	✓	✓	✓
BI39	X	X	✓	✓	✓
BI40	X	X	✓	✓	✓
BL22	X	X	✓	✓	✓
BL23	X	X	✓	✓	✓
BL24	X	X	✓	✓	✓
BL25	X	✓	✓	✓	✓
BL26	X	✓	✓	✓	✓
BL27	X	✓	X	✓	X

ART.					
	art. BZ64	art. BZ65 BZ66 **	art. BZ64 + art. BZ63	art. BZ65 BZ66 ** + art. BZ63	art. BZ64 + art. BZ65 BZ66 BZ67 ** + art. BZ63
BI31	X	X	✓	✓	✓
BI32	X	X	✓	✓	✓
BI33	X	X	✓	✓	✓
BI34	X	X	✓	✓	✓
BI35	✓	✓	✓	✓	✓
BI36	✓	✓	✓	✓	✓
BI37	X	✓	✓	✓	✓

\*\*

- I N.B.: L'art. BZ52- BZ66 - 1154 può essere installato soltanto sugli articoli BI31- BI32 - BI33 - BI34 - BI38 - BI39 - BI40 - BL22 - BL23
- GB N.B.: Art. BZ52- BZ66 - 1154 may only be fitted on art. BI31- BI32 - BI33 - BI34 - BI38 - BI39 - BI40 - BL22 - BL23
- F N.B.: Les art. BZ52- BZ66 - 1154 ne peut être installé que sur les art. BI31 - BI32 - BI33 - BI34 - BI38 - BI39 - BI40 - BL22 - BL23
- D N.B.: Art. BZ52- BZ66 - 1154 kann nur auf Art. BI31- BI32 - BI33 - BI34 - BI38 - BI39 - BI40 - BL22 - BL23 installiert werden.
- NL N.B.: Art. BZ52- BZ66 - 1154 kan allen worden geïnstalleerd op art. BI31- BI32 - BI33 - BI34 - BI38 - BI39 - BI40 - BL22 - BL23
- E NOTA: art. BZ52- BZ66 - 1154 puede instalarse únicamente en los art. BI31- BI32 - BI33 - BI34 - BI38 - BI39 - BI40 - BL22 - BL23.
- DK N.B.: Art. BZ52- BZ66 - 1154 kan kun installeres på artiklerne BI31- BI32 - BI33 - BI34 - BI38 - BI39 - BI40 - BL22 - BL23.
- N N.B.: Art. BZ52- BZ66 - 1154 kan kun monteres på art. BI31- BI32 - BI33 - BI34 - BI38 - BI39 - BI40 - BL22 - BL23.
- S OBS! Art. BZ52- BZ66 - 1154 kan endast installeras på artiklarna BI31- BI32 - BI33 - BI34 - BI38 - BI39 - BI40 - BL22 - BL23.
- RUS ПРИМЕЧАНИЕ: Арт. BZ52 - BZ66 - 1154 может быть установлен только на артикулах BI31 - BI32 - BI33 - BI34 - BI38 - BI39 - BI40 - BL22 - BL23.
- CN 注意事项: BZ52 - BZ66 - 1154 号产品只可以安装在 BD31 - BD32 - BD33 - BD34 - BD38 - BD39 - BD40 - BL22 - BL23 产品上。

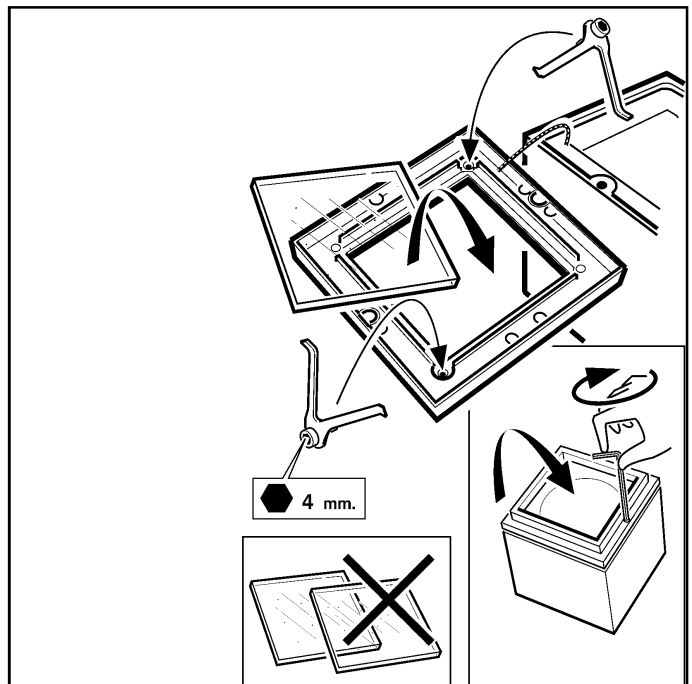
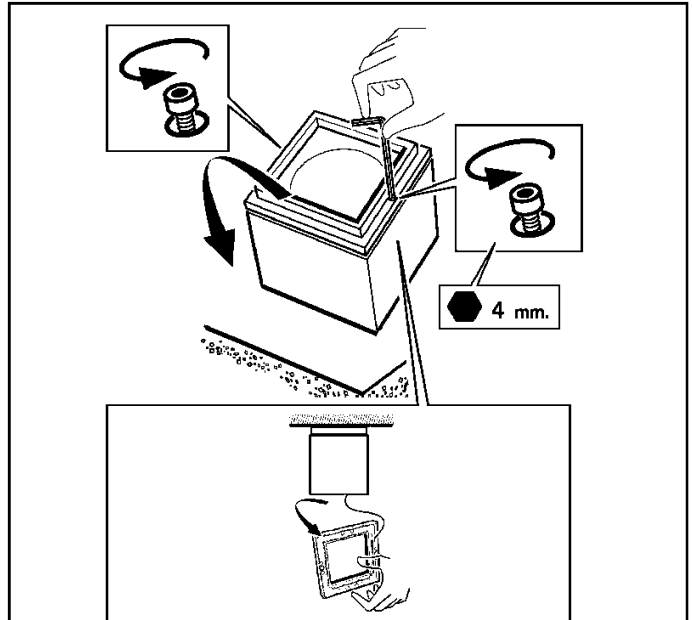
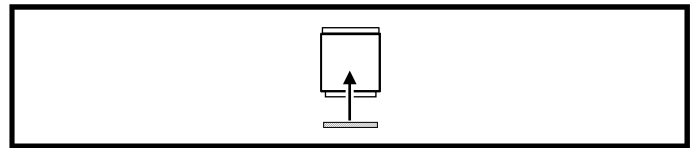



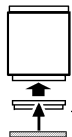

art. BZ77  
BZ63 - BZ49

art. BZ67

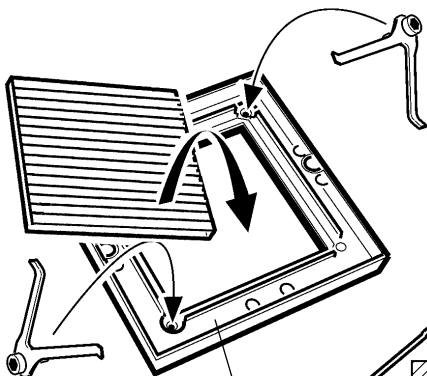
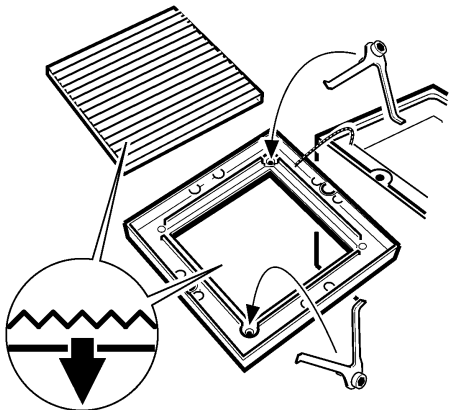
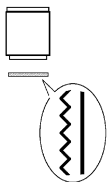

art. BZ77  
BZ63 - BZ49

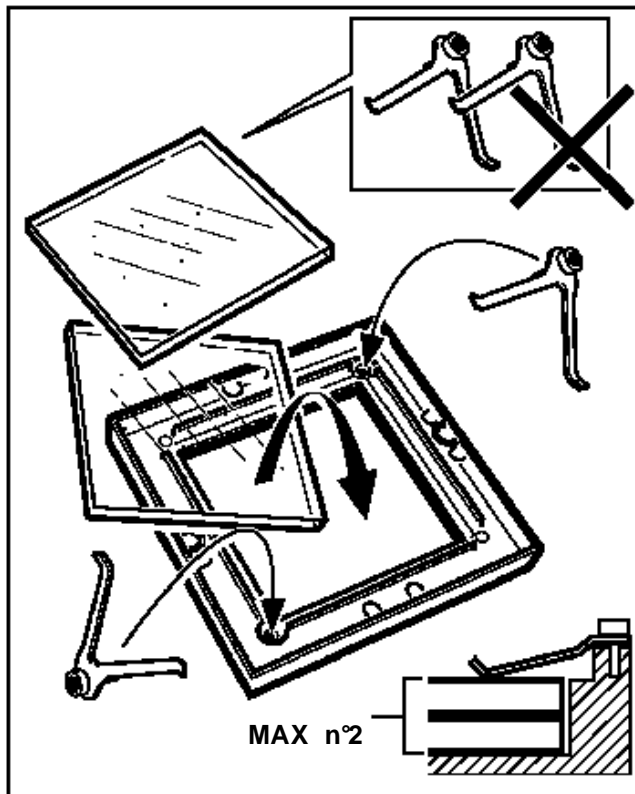
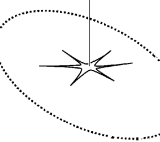
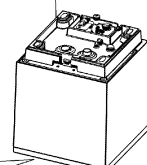
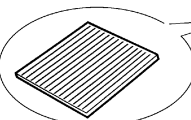
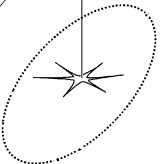
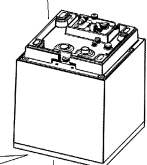
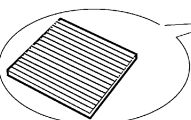
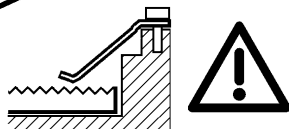

MAX n°2

art. BZ77  
BZ63 - BZ49

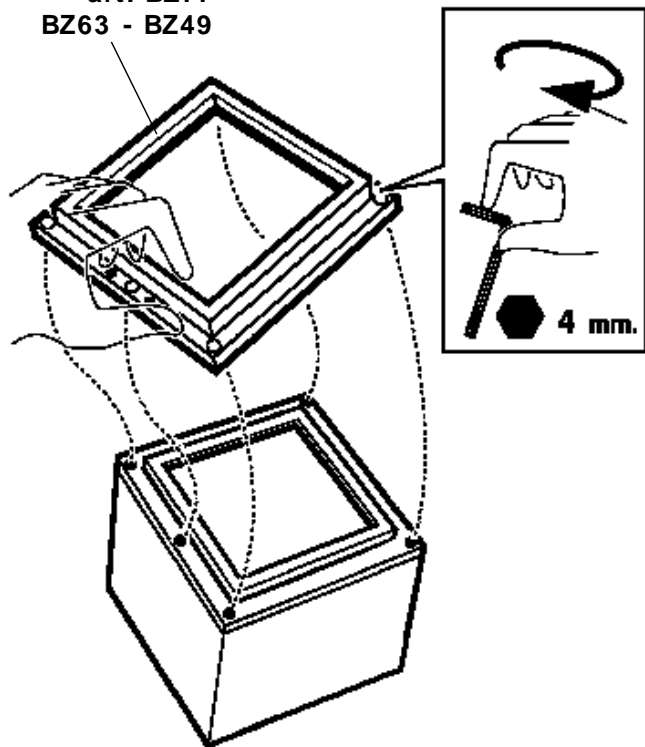

4 mm.

ART.	fattore di potenza power factor facteur de puissance Leistungsfaktor vermogensfactor factor de potencia effektfaktor effektfaktor effektfaktor фактор мощности 功率因数	corrente assorbita absorbed current courant absorbé Stromaufnahme stroomopname corriente absorbida absorberet strøm absorbert strøm tillförd ström поглощаемая мощность 电源电流  (A)
BD32 - BD33	> 0,9	0,125
BD38	> 0,95	0,210
BD39 - BD50	1	-
BD40 - BD41 - BD42 - BD43 - BI37	> 0,95	0,200
BD44 - BD45	> 0,9	0,230
BD51 - BI35	0,6	0,140
BD52 - BD53 - BD54 - BD55 - BD56 - BL26	> 0,95	0,350
BD57 - BD58	> 0,9	0,420
BD59 - BD61 - BL27	> 0,9	0,800
BG35 - BG36 - BG37 - BG38 - BI38 - BI39 - BI40 - BL22 BL23 - BL24 - BD34 - BD35 - BD36 - BD37 - BD46 - BD47 BD48 - BD49 - BI31 - BI32 - BI33 - BI34	0,9	> 0,15
BI36	0,95	> 0,11
BL25	0,93	> 0,12

ART.	fattore di potenza power factor facteur de puissance Leistungsfaktor vermogensfactor factor de potencia effektfaktor effektfaktor effektfaktor фактор мощности 功率因数	corrente assorbita absorbed current courant absorbé Stromaufnahme stroomopname corriente absorbida absorberet strøm absorbert strøm tillförd ström поглощаемая мощность 电源电流  (A)
BD32 - BD33	> 0,9	0,125
BD38	> 0,95	0,210
BD39 - BD50	1	-
BD40 - BD41 - BD42 - BD43 - BI37	> 0,95	0,200
BD44 - BD45	> 0,9	0,230
BD51 - BI35	0,6	0,140
BD52 - BD53 - BD54 - BD55 - BD56 - BL26	> 0,95	0,350
BD57 - BD58	> 0,9	0,420
BD59 - BD61 - BL27	> 0,9	0,800
BG35 - BG36 - BG37 - BG38 - BI38 - BI39 - BI40 - BL22 BL23 - BL24 - BD34 - BD35 - BD36 - BD37 - BD46 - BD47 BD48 - BD49 - BI31 - BI32 - BI33 - BI34	0,9	> 0,15
BI36	0,95	> 0,11
BL25	0,93	> 0,12

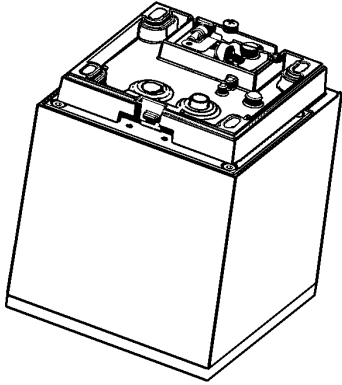

## iPRO PLAFONE

تحذير:

لا يمكن ضمان سلامة هذا الجهاز إلا إذا التزمت بهذه التعليمات. يجب حفظها في مكان آمن.

### ATTENZIONE:

LA SICUREZZA DELL'APPARECCHIO E' GARANTITA SOLO CON L'USO APPROPRIATO DELLE SEGUENTI ISTRUZIONI; PERTANTO E' NECESSARIO CONSERVARLE.

### WARNING:

THE SAFETY OF THIS FIXTURE IS GUARANTEED ONLY IF YOU COMPLY WITH THESE INSTRUCTIONS; REMEMBER TO CONSERVE IN A SAFE PLACE.

### ATENCION:

LA SEGURIDAD DEL APARATO SE GARANTIZA SOLO CUMPLIENDO CUIDADOSAMENTE LAS SIGUIENTES INSTRUCCIONES; POR ELLO, ES NECESARIO CONSERVARLAS.

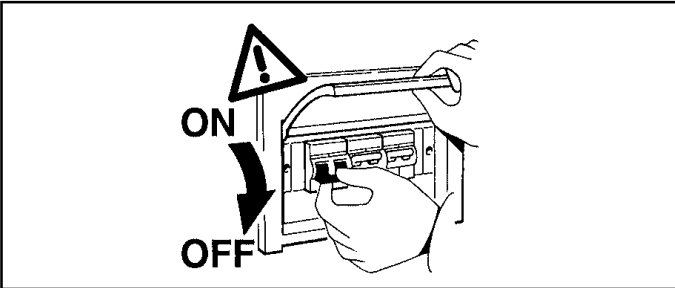

⊙...m

الترزم بالحد الأدنى من المسافة عن التركيبية الضوئية، المقاس عر على امتداد المحاور المرئية في اللمبة.

I Rispettare la distanza minima dall'oggetto illuminato, misurata lungo l'asse ottico della lampada.

GB Respect the minimum distance from the illuminated object, measured along the optical axis of the lamp.

E Respetar la distancia mínima respecto del objeto iluminado, medida a lo largo del eje óptico de la lámpara.

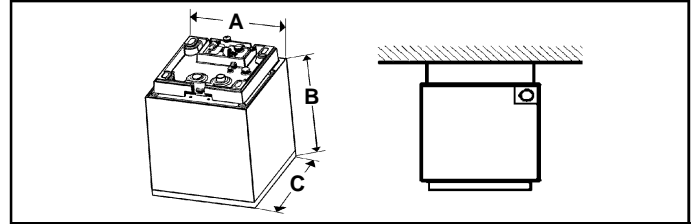

الصنف ART.	الوزن PESO WEIGHT PESO (Kg) كغم	الأبعاد Dimensioni Dimensions Dimensiones	السطح Superficie Surface Superficie
L	8,4	192 x 202 x 192 ملم	(mq) م <sup>2</sup>
M	4,6	155 x 165 x 155	0,026

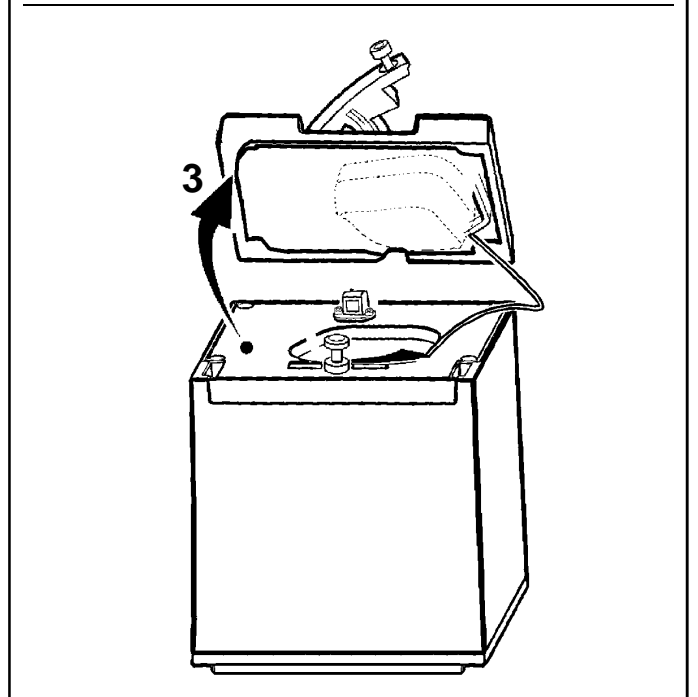
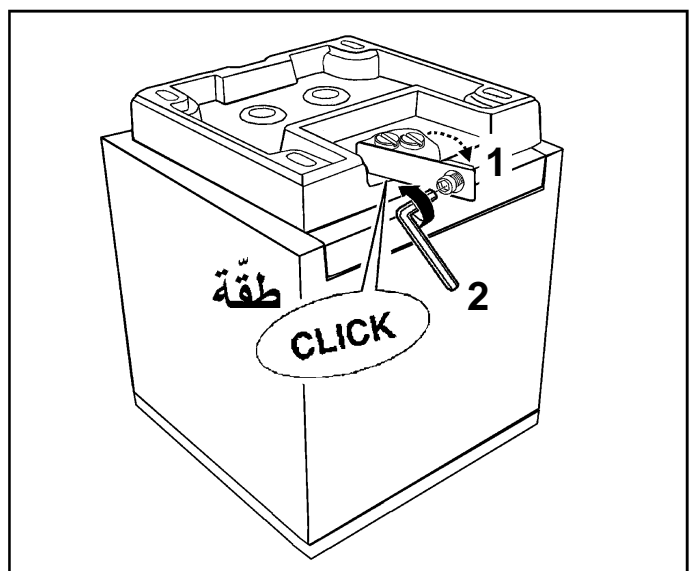

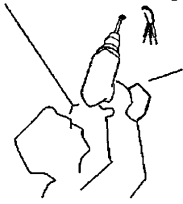
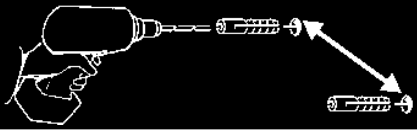

**M**

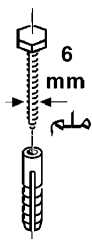
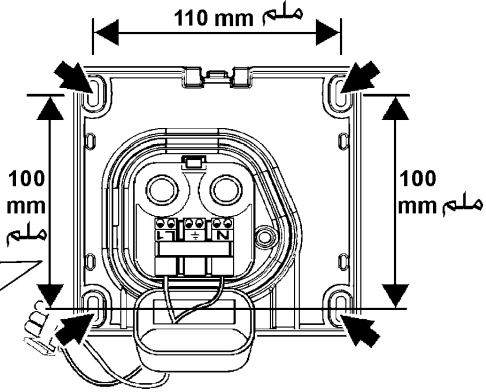

**L**

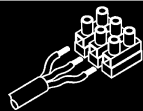
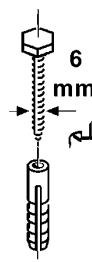
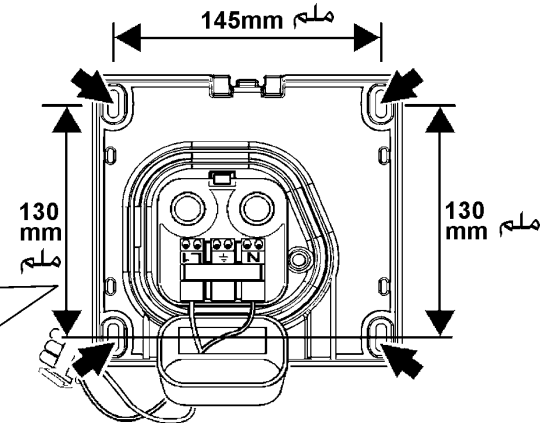

الصف art. BI31 - BI32 - BI33  
BI34 - BI38 - BI39  
BI40 - BL22 - BL23  
BL24 - BL25 - BL26  
BL27

بهدف اختبار المنتج، تم ملائمة للكبلات المبينة في الرسم. عر  
ملاحظة: أزل هذه الكبلات قبل توصيل المنتج.

I Per esigenze di collaudo, il prodotto è stato munito dei cavi indicati in figura.  
N.B.: Asportare tali cavi prima di effettuare il cablaggio del prodotto.

GB In order to test the product, it was fitted with the cables indicated in the figure.  
N.B.: Remove these cables before wiring the product.

E Debido a exigencias de ensayo, el producto ha sido provisto de los cables indicados en la figura.  
NOTA: Extraer dichos cables antes de realizar el cableo del producto.

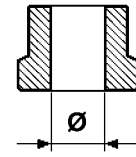
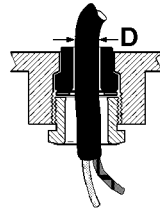
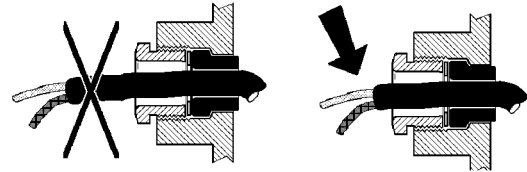

D ( mm ) ملم	Ø ( mm ) ملم
8,5 ÷ 11	10
10,5 ÷ 12,5	12

الصف art. BI31 - BI32 - BI33  
BI34 - BI35 - BI36  
BI37 - BI38 - BI39  
BI40 - BL22 - BL23  
BL24 - BL25 - BL26  
BL27

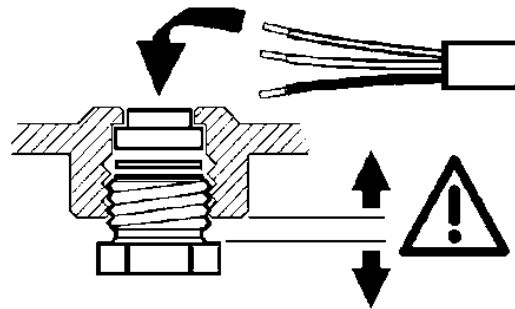
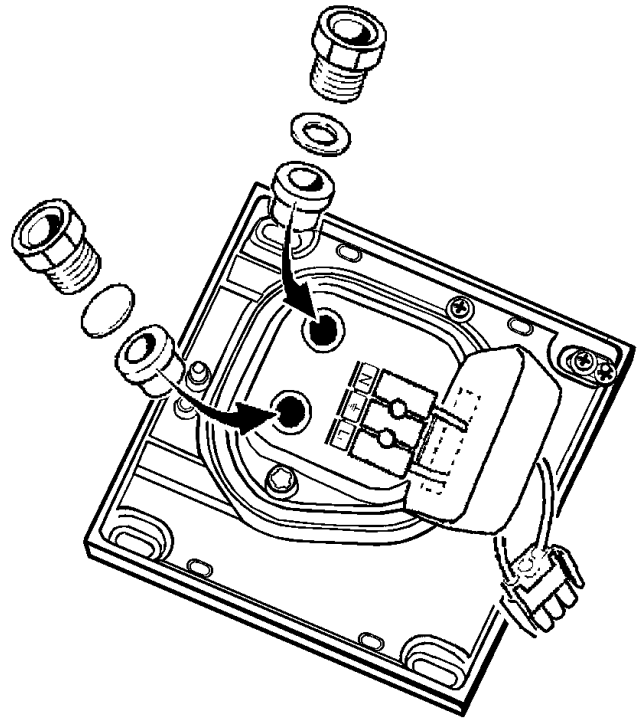

الصنف art. BL27

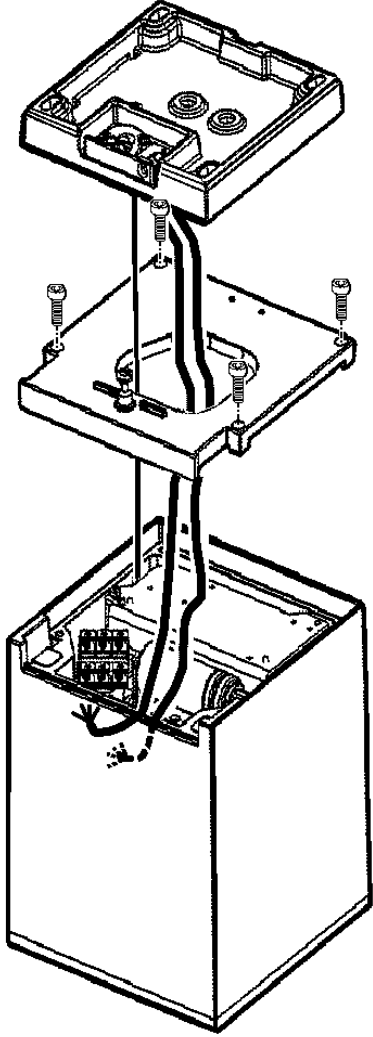

الصنف ART.	A mm ملم	B mm ملم	C mm ملم
art. BI35 - BI36 - BI37			9 ÷ 10
art. BI31 - BI32 - BI33 BI34 - BI38 - BI39 BI40 - BL22 - BL23 BL24 - BL25 - BL26	3 ÷ 4	50	10 ÷ 11
art. BL27		300	

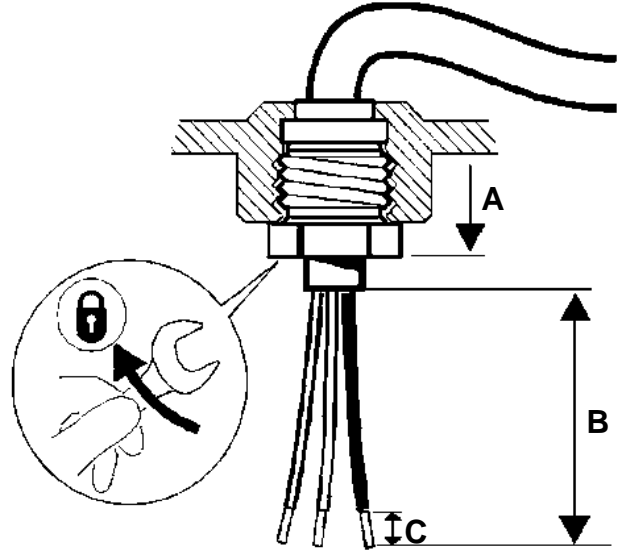

الصنف art. BI31 - BI32 - BI33  
BI34 - BI35 - BI36  
BI37 - BI38 - BI39  
BI40 - BL22 - BL23  
BL24 - BL25 - BL26

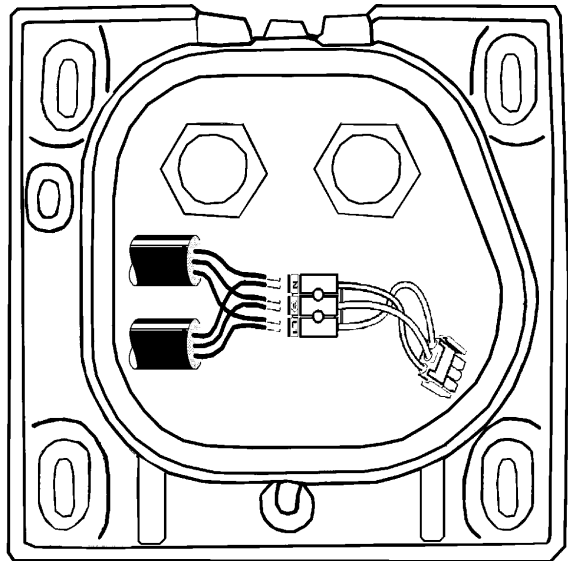
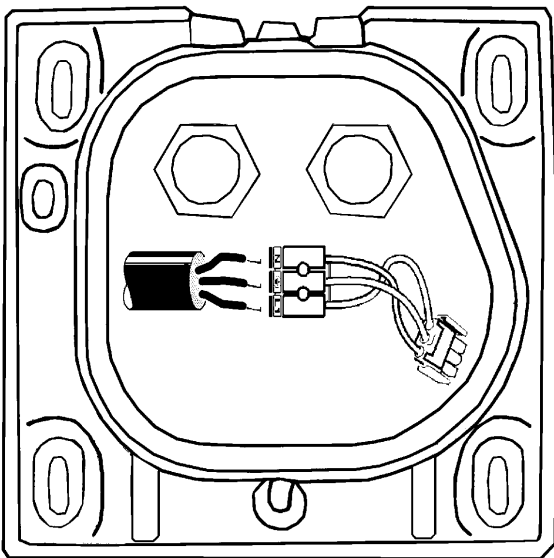

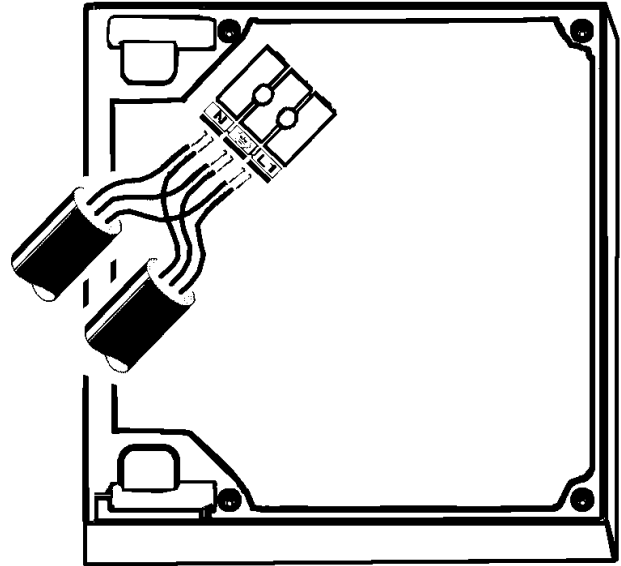
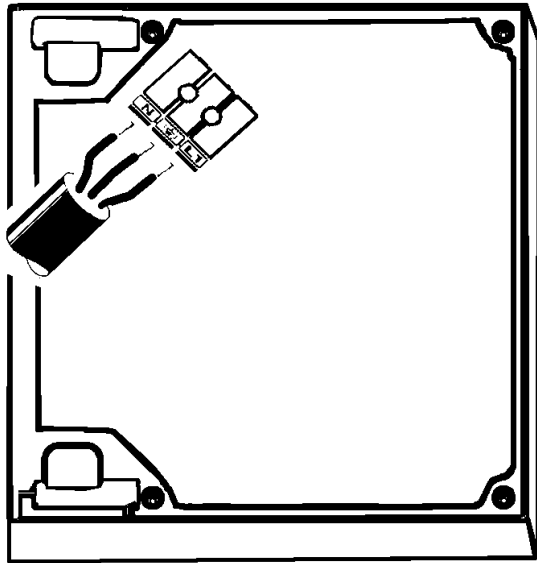

الصنف art. BI31 - BI32 - BI33  
BI34 - BI35 - BI36  
BI37 - BI38 - BI39  
BI40 - BL22 - BL23  
BL24 - BL25 - BL26  
BL27

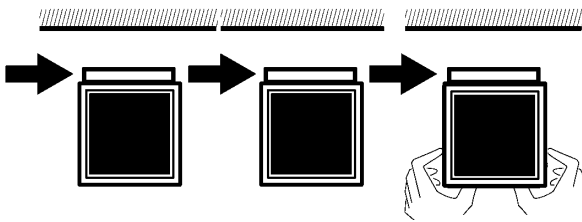

2,5 mm<sup>2</sup>  
ملم<sup>2</sup>

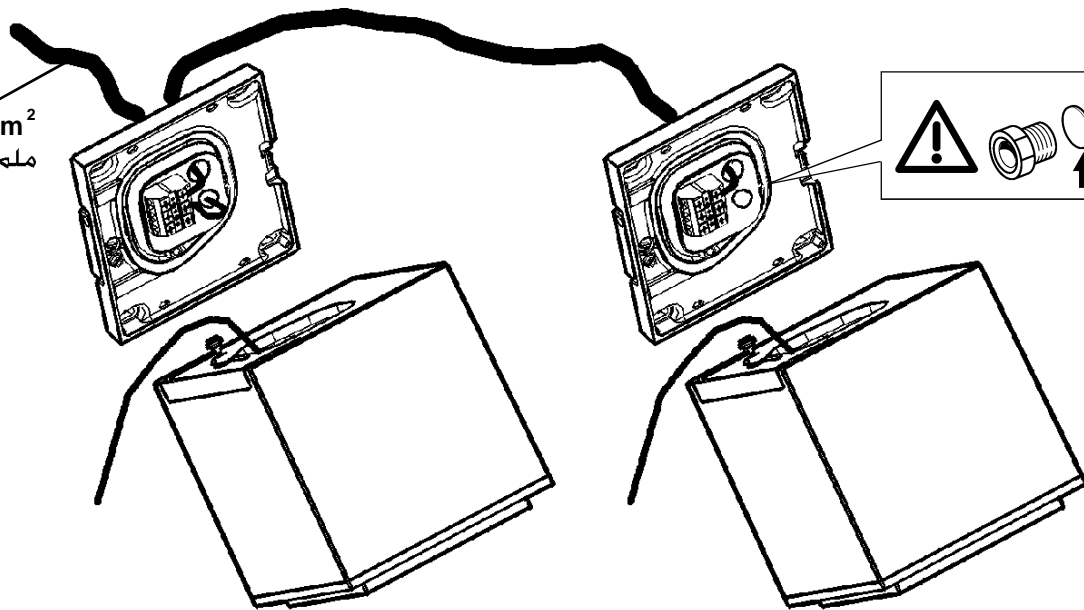

الصف art. BI31 - BI32 - BI33  
 BI34 - BI35 - BI36  
 BI37 - BI38 - BI39  
 BI40 - BL22 - BL23  
 BL24 - BL25 - BL26  
 BL27

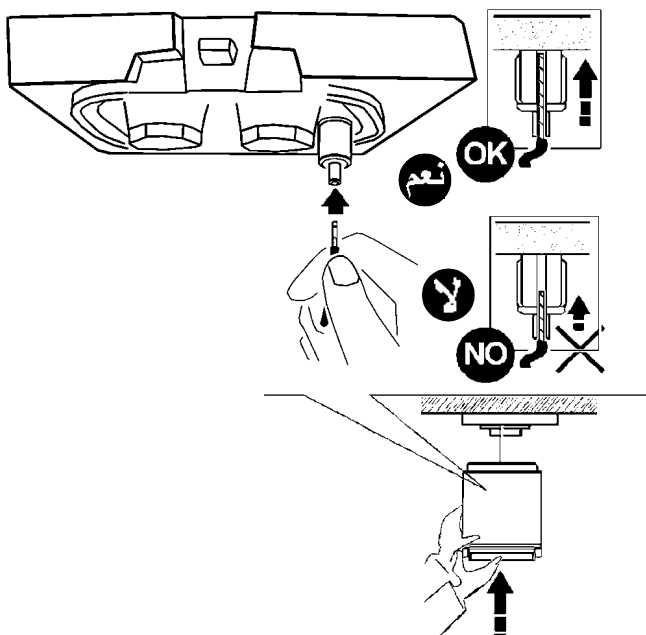

الصف art. BI31 - BI32 - BI33  
 BI34 - BI35 - BI36  
 BI37 - BI38 - BI39  
 BI40 - BL22 - BL23  
 BL24 - BL25 - BL26

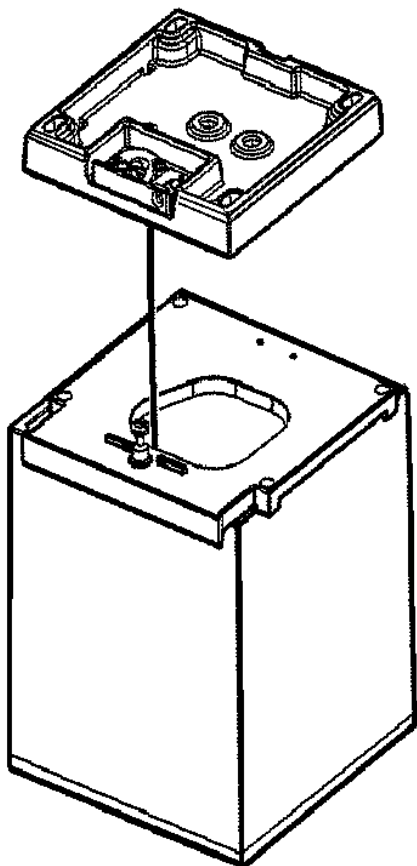

الصف art. BI31 - BI32 - BI33  
 BI34 - BI35 - BI36  
 BI37 - BI38 - BI39  
 BI40 - BL22 - BL23  
 BL24 - BL25 - BL26

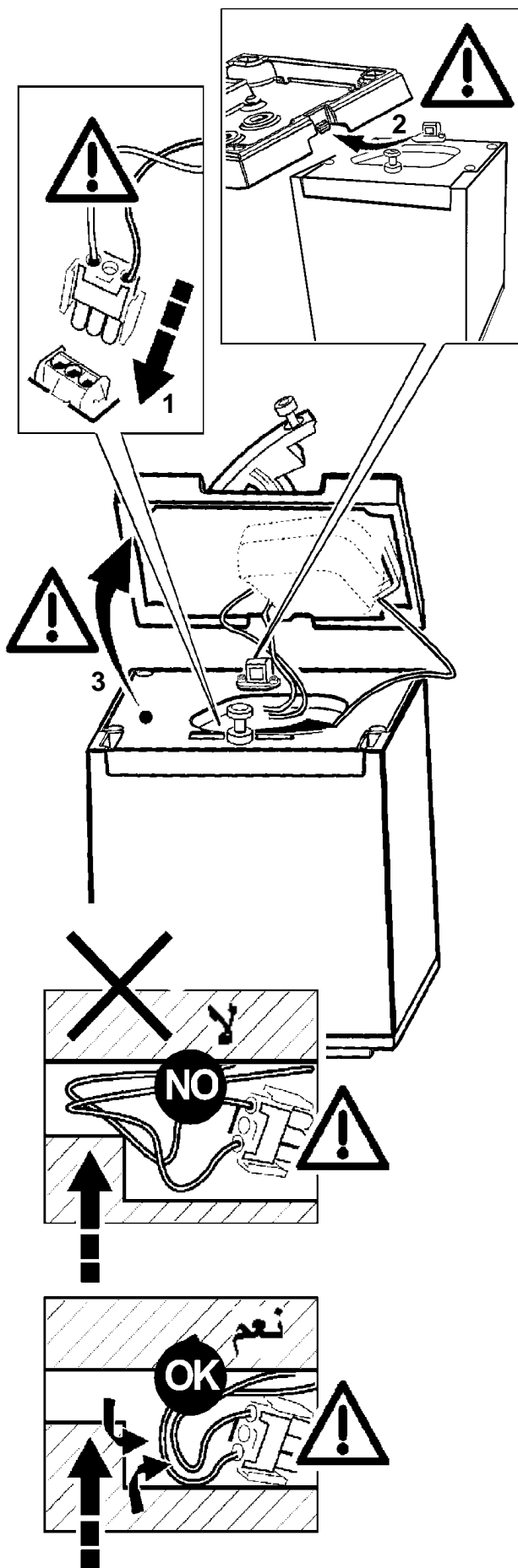

الصفحة art. BL27

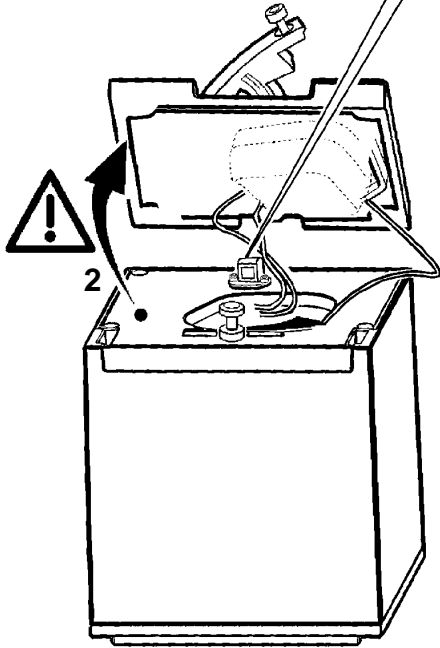
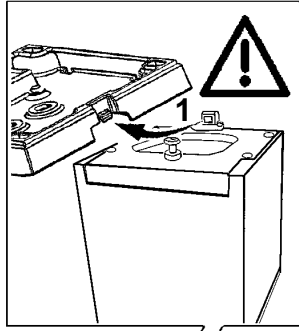

عند تصميم جهاز الإضاءة والتصديقات الكهربائية، حدد الحد الأقصى للتيار المسموح به من خلال العوامل التالية:  
 - 16A: تيار اسمي مسموح به من قبل لوحات أطراف التوصيل (BI35);  
 - 20A: تيار اسمي مسموح به من قبل لوحات أطراف التوصيل (BI31 - BI32 - BI33 - BI34 - BI38 - BI39 - BI40 - BL22 - BL23 - BL24 - BL25 - BL26 - BL27);  
 - عامل الأمان للأخذ بعين الاعتبار جاور الفلغطة والتزامن;  
 - الفلغطة الاسمية الممنوعة من قبل الأصناف المقردة.  
 ينصح بعدم تشغيل موصلات الكيبلات ضمن قيم الحد الأقصى.

I Nella progettazione dell'impianto illuminotecnico ed elettrico, determinare le correnti massime ammissibili, considerando i seguenti fattori:  
 - 16A: corrente nominale ammessa dalle morsettiere (BI35);  
 - 20A: corrente nominale ammessa dalle morsettiere (BI31 - BI32 - BI33 - BI34 - BI38 - BI39 - BI40 - BL22 - BL23 - BL24 - BL25 - BL26 - BL27);  
 - coefficiente di sicurezza per tenere conto delle sovratensioni e contemporaneità;  
 - corrente nominale assorbita dai singoli art.  
 E' buona norma evitare di far lavorare i conduttori dei cavi ai massimi valori.

GB When planning the lighting and electrical system, determine the maximum permitted current, taking into account the following factors:  
 - 16A: the nominal current permitted by terminal blocks (BI35);  
 - 20A: the nominal current permitted by terminal blocks (BI31 - BI32 - BI33 - BI34 - BI38 - BI39 - BI40 - BL22 - BL23 - BL24 - BL25 - BL26 - BL27);  
 - safety coefficient to allow for excess voltage and contemporaneity;  
 - the nominal current absorbed by single art.  
 It is recommended that the wires inside the cables are made to operate at the maximum values.

E Durante la proyectación de la instalación luminotécnica y eléctrica, determinar las corrientes máximas permitidas, en consideración de los factores siguientes:  
 - 16A: corriente nominal permitida de las borneras (BI35);  
 - 20A: corriente nominal permitida de las borneras (BI31 - BI32 - BI33 - BI34 - BI38 - BI39 - BI40 - BL22 - BL23 - BL24 - BL25 - BL26 - BL27);  
 - coeficiente de seguridad para considerar sobretensiones y contemporaneidades;  
 - corriente nominal absorbida por los art. individuales.  
 Se aconseja evitar que los conductores de cables trabajen con valores máximos.



الصفحة art. BI35 - BI36 - BI37  
 BL25 - BL26 - BL27

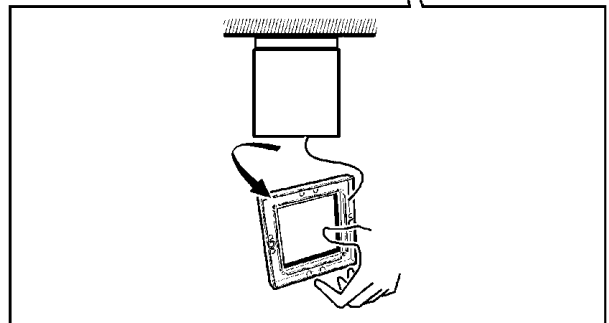
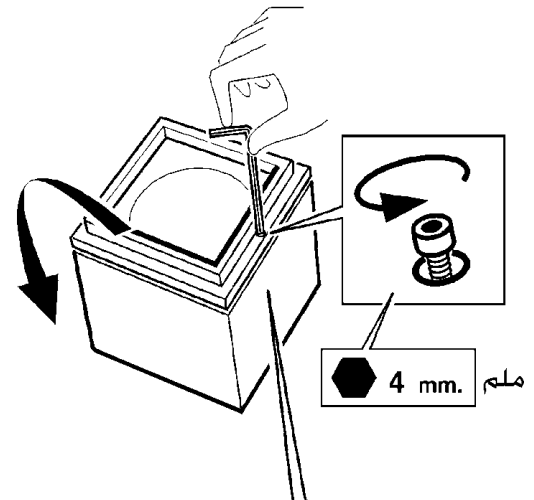

الصفحة art. BI31 - BI32 - BI33  
 BI34 - BI35 - BI36  
 BI37 - BI38 - BI39  
 BI40 - BL22 - BL23  
 BL24 - BL25 - BL26  
 BL27

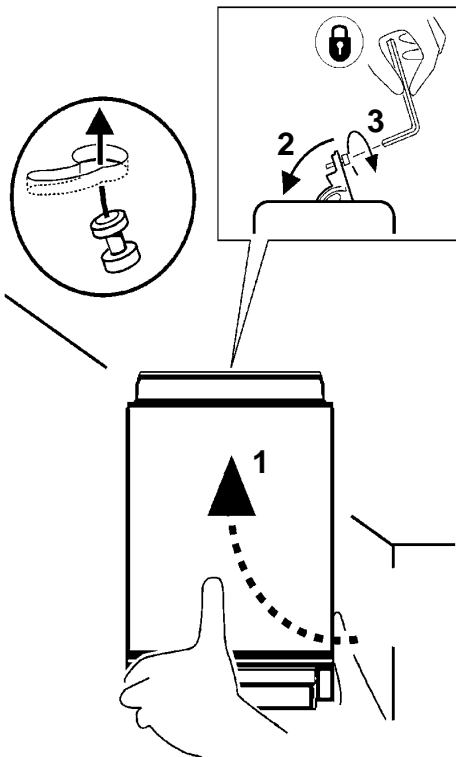



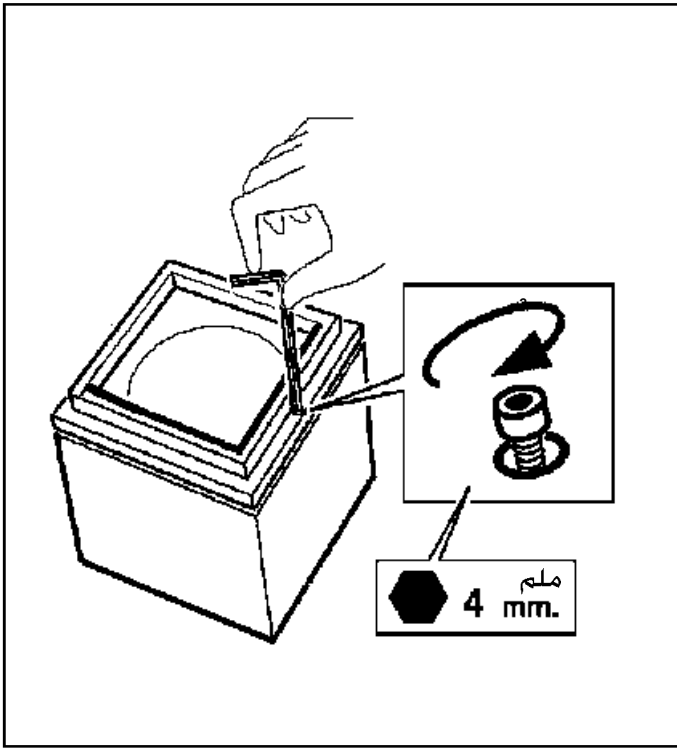

**ملاحظة: ملاحظة: أثناء تركيب نظام "iPRO". يجب التقيد بحرص بالنظم السائدة المتعلقة بالشبكة الكهربائية.**

N.B.: DURANTE L'INSTALLAZIONE DEL SISTEMA "iPRO" RISPETTARE SCRUPOLOSAMENTE LE NORME IMPIANTISTICHE VIGENTI.

N.B.: WHEN INSTALLING THE SYSTEM "iPRO", STRICTLY COMPLY WITH ALL REGULATIONS ON INSTALLATION IN FORCE.

N.B.: DURANTE LA INSTALACIÓN DEL SISTEMA "iPRO" RESPETAR ESCRUPULOSAMENTE LAS NORMAS DE INSTALACIÓN VIGENTES.

**تنبيه: لاستبدال الضوء LED اتصل بشركة iGuzzini.**

I N.B.: Per la sostituzione del LED contattare l'azienda iGuzzini.

GB N.B.: For information on LED replacement please contact iGuzzini.

E NOTA: Para sustituir el LED llame a la empresa iGuzzini.

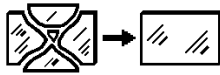

لا يمكن استعمال المنتج في حالة كسر الزجاج، وبالتالي يجب الاتصال بالصانع لاستبداله.

I In caso di rottura del vetro il prodotto non può essere utilizzato, contattare il costruttore per la sua sostituzione.

GB Should the glass break, the product cannot be used and you should contact the manufacturer for its replacement.

E No utilizar el producto en caso de ruptura del vidrio y contactar el fabricante para la sustitución.

⊕ art.					
			الصف art. BZ77		
الصف ART.	art. BZ78	art. BZ79	art. BZ78 1154 + art. BZ77	art. BZ79 + art. BZ77	art. BZ78 + art. BZ79 BZ80 + art. BZ77
BI38	✗	✗	✓	✓	✓
BI39	✗	✗	✓	✓	✓
BI40	✗	✗	✓	✓	✓
BL22	✗	✗	✓	✓	✓
BL23	✗	✗	✓	✓	✓
BL24	✗	✗	✓	✓	✓
BL25	✗	✓	✓	✓	✓
BL26	✗	✓	✓	✓	✓
BL27	✗	✓	✗	✓	✗

⊕ art.					
			الصف art. BZ63		
الصف ART.	art. BZ64	art. BZ65 BZ66 **	art. BZ64 + art. BZ63	art. BZ65 BZ66 ** + art. BZ63	art. BZ64 + art. BZ65 BZ66 BZ67 ** + art. BZ63
BI31	✗	✗	✓	✓	✓
BI32	✗	✗	✓	✓	✓
BI33	✗	✗	✓	✓	✓
BI34	✗	✗	✓	✓	✓
BI35	✓	✓	✓	✓	✓
BI36	✗	✓	✓	✓	✓
BI37	✗	✓	✓	✓	✓

✳

ملاحظة : الصنف BZ52- BZ66 - 1154 يمكن تركيبه فقط على الأصناف BI31- BI32 - BI33 - BI34 - BI38 - BI39 - BI40 - BL22 - BL23

I N.B.: L'art. BZ52- BZ66 - 1154 può essere installato soltanto sugli articoli BI31- BI32 - BI33 - BI34 - BI38 - BI39 - BI40 - BL22 - BL23

GB N.B.: Art. BZ52- BZ66 - 1154 may only be fitted on art. BI31- BI32 - BI33 - BI34 - BI38 - BI39 - BI40 - BL22 - BL23

E NOTA: art. BZ52- BZ66 - 1154 puede instalarse únicamente en los art. BI31- BI32 - BI33 - BI34 - BI38 - BI39 - BI40 - BL22 - BL23.

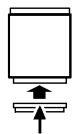
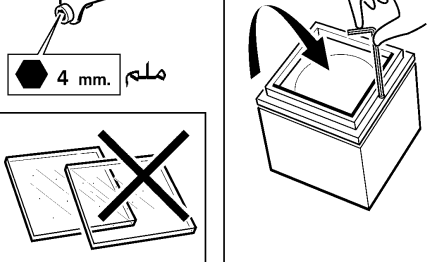
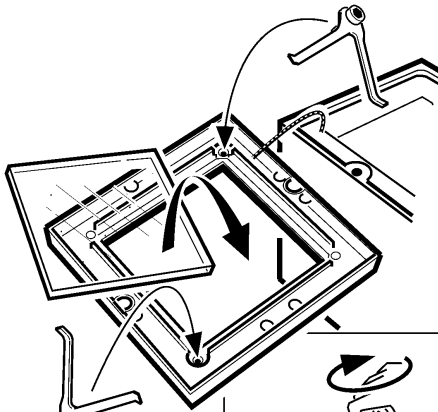
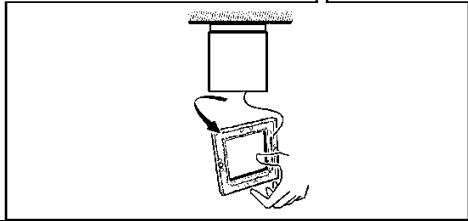
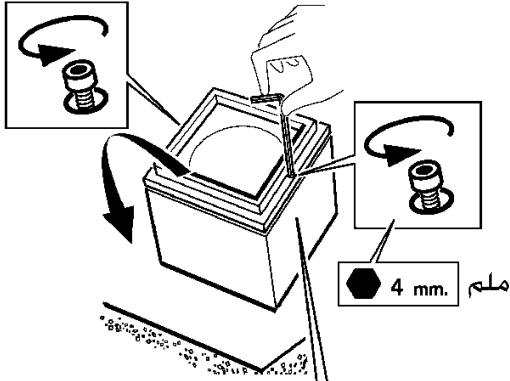
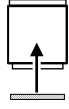

الصنف  
art. BZ77  
BZ63 - BZ49

art. BZ67 الصنف

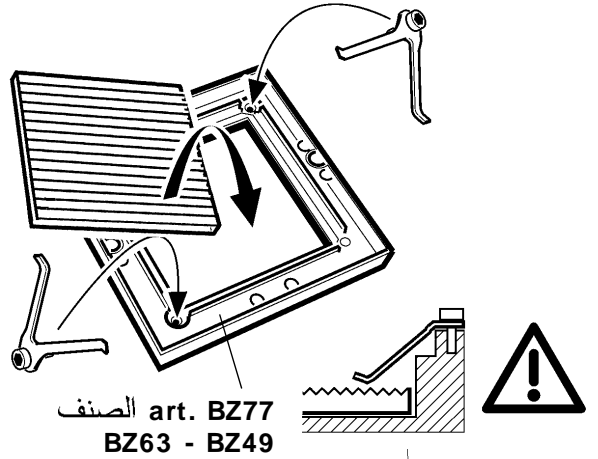
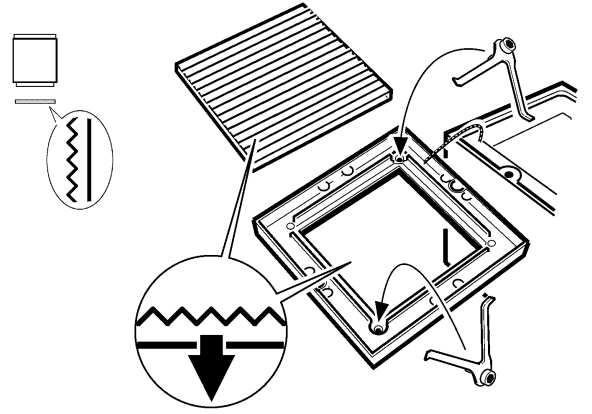

الصنف art. BZ77  
BZ63 - BZ49

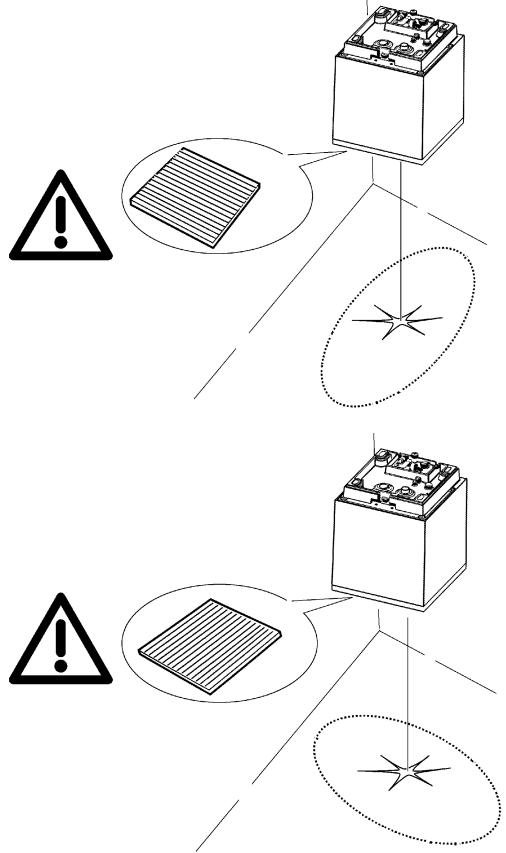

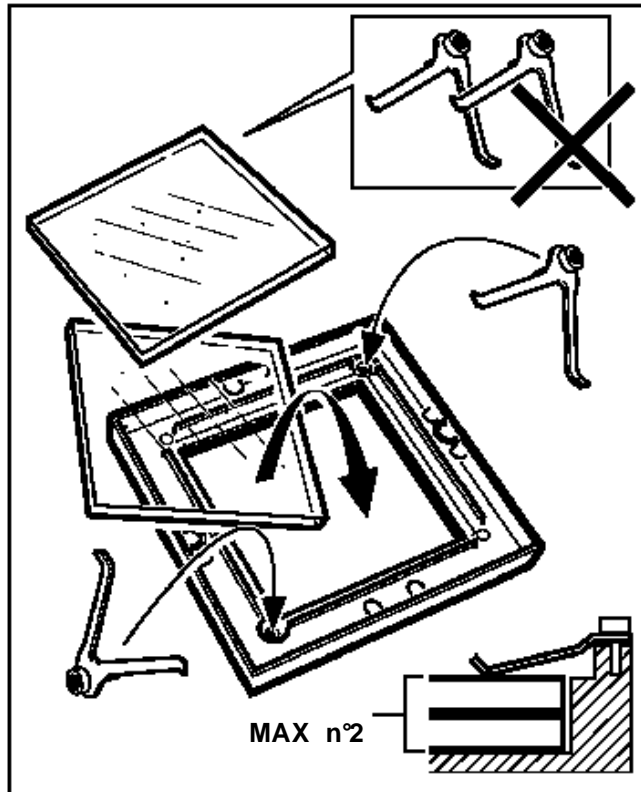

الصف  
art. BZ77  
BZ63 - BZ49

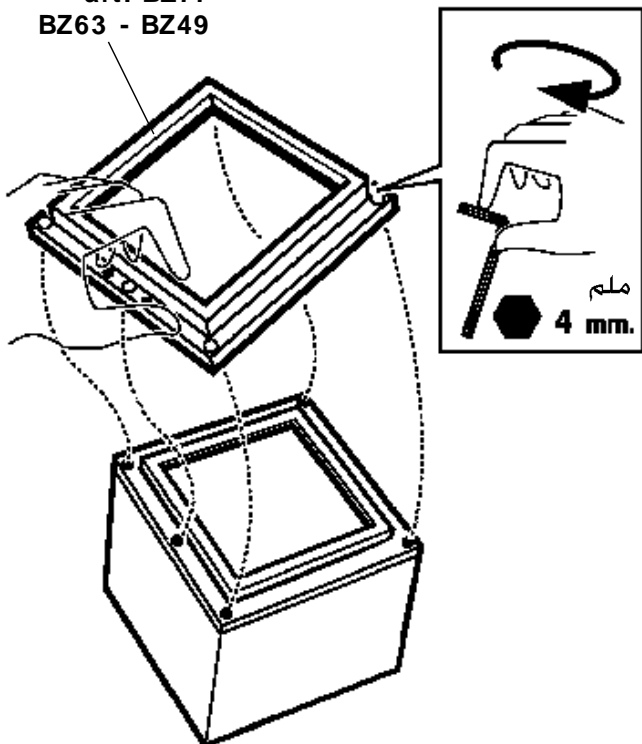

**I** Nel serrare il pressacavo, assicurarsi che il gommino "G" non fuoriesca dalla parte opposta della sua sede.

**GB** When tightening the cable-clamp, make sure rubber "G" does not come out on the other side of its housing.

**F** Lorsque vous serrez le serre-fils, veillez à ce que le caoutchouc "G" ne sorte pas de l'autre côté de son logement.

**D** Bei Befestigen der Kabelschelle ist darauf zu achten, dass der Gummistöpsel "G" nicht an der anderen Seite seines Sitzes herausragt.

**NL** Bij het vast draaien van de kabelklem moet u erop letten dat het rubber deeltje "G" niet aan de andere kant uitsteekt.

**E** Al apretar el sujetacable asegurarse de que la goma "G" no sobresalga de la parte opuesta de su alojamiento.

**DK** Når kabelholderen spændes, skal man sikre sig, at gummidelen "G" ikke rager ud på den modsatte side.

**N** I det kableklemmen strammes, se til at gummidelen "G" ikke komme rut på motsatt side av der den sitter.

**S** Kontrollera att gummidelen G inte kommer ut ur den motsatta delen när kabelklämman dras åt.

**RUS** При закрутке кабельного сальника проверить, чтобы резиновая муфта «G» не выходила из своего гнезда с противоположной стороны.

**CN** 在锁住电缆接头的时候, 首先保证"G"橡皮圈没有从相反的方向冒出来。

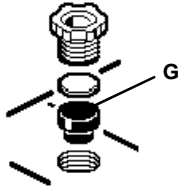

**I** Nel serrare il pressacavo, assicurarsi che il gommino "G" non fuoriesca dalla parte opposta della sua sede.

**GB** When tightening the cable-clamp, make sure rubber "G" does not come out on the other side of its housing.

**F** Lorsque vous serrez le serre-fils, veillez à ce que le caoutchouc "G" ne sorte pas de l'autre côté de son logement.

**D** Bei Befestigen der Kabelschelle ist darauf zu achten, dass der Gummistöpsel "G" nicht an der anderen Seite seines Sitzes herausragt.

**NL** Bij het vast draaien van de kabelklem moet u erop letten dat het rubber deeltje "G" niet aan de andere kant uitsteekt.

**E** Al apretar el sujetacable asegurarse de que la goma "G" no sobresalga de la parte opuesta de su alojamiento.

**DK** Når kabelholderen spændes, skal man sikre sig, at gummidelen "G" ikke rager ud på den modsatte side.

**N** I det kableklemmen strammes, se til at gummidelen "G" ikke komme rut på motsatt side av der den sitter.

**S** Kontrollera att gummidelen G inte kommer ut ur den motsatta delen när kabelklämman dras åt.

**RUS** При закрутке кабельного сальника проверить, чтобы резиновая муфта «G» не выходила из своего гнезда с противоположной стороны.

**CN** 在锁住电缆接头的时候, 首先保证"G"橡皮圈没有从相反的方向冒出来。

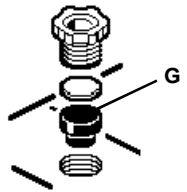

**I** Nel serrare il pressacavo, assicurarsi che il gommino "G" non fuoriesca dalla parte opposta della sua sede.

**GB** When tightening the cable-clamp, make sure rubber "G" does not come out on the other side of its housing.

**F** Lorsque vous serrez le serre-fils, veillez à ce que le caoutchouc "G" ne sorte pas de l'autre côté de son logement.

**D** Bei Befestigen der Kabelschelle ist darauf zu achten, dass der Gummistöpsel "G" nicht an der anderen Seite seines Sitzes herausragt.

**NL** Bij het vast draaien van de kabelklem moet u erop letten dat het rubber deeltje "G" niet aan de andere kant uitsteekt.

**E** Al apretar el sujetacable asegurarse de que la goma "G" no sobresalga de la parte opuesta de su alojamiento.

**DK** Når kabelholderen spændes, skal man sikre sig, at gummidelen "G" ikke rager ud på den modsatte side.

**N** I det kableklemmen strammes, se til at gummidelen "G" ikke komme rut på motsatt side av der den sitter.

**S** Kontrollera att gummidelen G inte kommer ut ur den motsatta delen när kabelklämman dras åt.

**RUS** При закрутке кабельного сальника проверить, чтобы резиновая муфта «G» не выходила из своего гнезда с противоположной стороны.

**CN** 在锁住电缆接头的时候, 首先保证"G"橡皮圈没有从相反的方向冒出来。

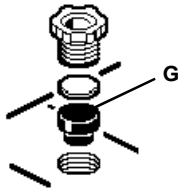

**I** Nel serrare il pressacavo, assicurarsi che il gommino "G" non fuoriesca dalla parte opposta della sua sede.

**GB** When tightening the cable-clamp, make sure rubber "G" does not come out on the other side of its housing.

**F** Lorsque vous serrez le serre-fils, veillez à ce que le caoutchouc "G" ne sorte pas de l'autre côté de son logement.

**D** Bei Befestigen der Kabelschelle ist darauf zu achten, dass der Gummistöpsel "G" nicht an der anderen Seite seines Sitzes herausragt.

**NL** Bij het vast draaien van de kabelklem moet u erop letten dat het rubber deeltje "G" niet aan de andere kant uitsteekt.

**E** Al apretar el sujetacable asegurarse de que la goma "G" no sobresalga de la parte opuesta de su alojamiento.

**DK** Når kabelholderen spændes, skal man sikre sig, at gummidelen "G" ikke rager ud på den modsatte side.

**N** I det kableklemmen strammes, se til at gummidelen "G" ikke komme rut på motsatt side av der den sitter.

**S** Kontrollera att gummidelen G inte kommer ut ur den motsatta delen när kabelklämman dras åt.

**RUS** При закрутке кабельного сальника проверить, чтобы резиновая муфта «G» не выходила из своего гнезда с противоположной стороны.

**CN** 在锁住电缆接头的时候, 首先保证"G"橡皮圈没有从相反的方向冒出来。

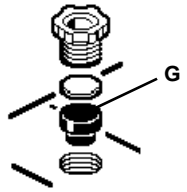

**I** Nel serrare il pressacavo, assicurarsi che il gommino "G" non fuoriesca dalla parte opposta della sua sede.

**GB** When tightening the cable-clamp, make sure rubber "G" does not come out on the other side of its housing.

**F** Lorsque vous serrez le serre-fils, veillez à ce que le caoutchouc "G" ne sorte pas de l'autre côté de son logement.

**D** Bei Befestigen der Kabelschelle ist darauf zu achten, dass der Gummistöpsel "G" nicht an der anderen Seite seines Sitzes herausragt.

**NL** Bij het vast draaien van de kabelklem moet u erop letten dat het rubber deeltje "G" niet aan de andere kant uitsteekt.

**E** Al apretar el sujetacable asegurarse de que la goma "G" no sobresalga de la parte opuesta de su alojamiento.

**DK** Når kabelholderen spændes, skal man sikre sig, at gummidelen "G" ikke rager ud på den modsatte side.

**N** I det kableklemmen strammes, se til at gummidelen "G" ikke komme rut på motsatt side av der den sitter.

**S** Kontrollera att gummidelen G inte kommer ut ur den motsatta delen när kabelklämman dras åt.

**RUS** При закрутке кабельного сальника проверить, чтобы резиновая муфта «G» не выходила из своего гнезда с противоположной стороны.

**CN** 在锁住电缆接头的时候, 首先保证"G"橡皮圈没有从相反的方向冒出来。

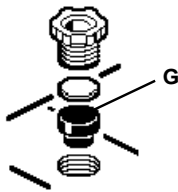

**I** Nel serrare il pressacavo, assicurarsi che il gommino "G" non fuoriesca dalla parte opposta della sua sede.

**GB** When tightening the cable-clamp, make sure rubber "G" does not come out on the other side of its housing.

**F** Lorsque vous serrez le serre-fils, veillez à ce que le caoutchouc "G" ne sorte pas de l'autre côté de son logement.

**D** Bei Befestigen der Kabelschelle ist darauf zu achten, dass der Gummistöpsel "G" nicht an der anderen Seite seines Sitzes herausragt.

**NL** Bij het vast draaien van de kabelklem moet u erop letten dat het rubber deeltje "G" niet aan de andere kant uitsteekt.

**E** Al apretar el sujetacable asegurarse de que la goma "G" no sobresalga de la parte opuesta de su alojamiento.

**DK** Når kabelholderen spændes, skal man sikre sig, at gummidelen "G" ikke rager ud på den modsatte side.

**N** I det kableklemmen strammes, se til at gummidelen "G" ikke komme rut på motsatt side av der den sitter.

**S** Kontrollera att gummidelen G inte kommer ut ur den motsatta delen när kabelklämman dras åt.

**RUS** При закрутке кабельного сальника проверить, чтобы резиновая муфта «G» не выходила из своего гнезда с противоположной стороны.

**CN** 在锁住电缆接头的时候, 首先保证"G"橡皮圈没有从相反的方向冒出来。

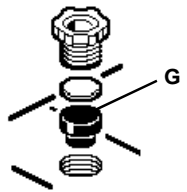

1.154.653.00  
ISO8370/03

# iGuzzini

SOSTITUZIONE DEL LED  
REPLACING THE LED  
REEMPLACEMENT DE LA LED  
AUSTAUSCHEN DER LED  
VERVANGEN VAN DE LED  
REEMPLAZO DEL LED  
UDSKIFTNING AF LYSDIODE  
BYTE AV LYSDIOD  
UTSKIFTING AV DEN LYSEMITTERENDE DIODEN

ЗАМЕНА СИДа  
发光二极管替换

- I** N.B.: Per la sostituzione del LED contattare l'azienda iGuzzini.  
**GB** N.B.: For information on LED replacement please contact iGuzzini.  
**F** N.B.: Pour procéder au remplacement de la LED, adressez-vous à la société iGuzzini.  
**D** Ñ.B.: Bezüglich des Austausches der LED kontaktieren Sie bitte die Firma iGuzzini.  
**NL** N.B.: Voor het vervangen van de LED neemt u contact op met het bedrijf iGuzzini.  
**E** NOTA: Para sustituir el LED llame a la empresa iGuzzini.  
**DK** N.B.: For udsiftning af lysdioden, skal man kontakte iGuzzini.  
**N** N.B.: For informasjon om skifte av LED, vennligst ta kontakt med iGuzzini.  
**S** OBS! För byte av lysdioden, kontakta företaget iGuzzini.  
**RUS** ПРИМЕЧАНИЕ: Для замены СИДов обращайтесь в компанию iGuzzini.  
**CN** 注意：如需LED更换的信息，请联系iGuzzini。

- I** L'apparecchio dovrebbe essere posizionato in modo che non sia prevista un'osservazione prolungata dell'apparecchio ad una distanza inferiore di 1 m.  
**GB** The luminaire should be positioned so that prolonged staring into the luminaire at a distance closer than 1 m is not expected.  
**FR** Il faudrait placer l'appareil de manière à ce qu'aucune observation prolongée de l'appareil ne soit possible à moins de 1 m de distance  
**D** Das Gerät so positionieren, dass der Anwender nicht über längere Zeit aus weniger als 1 m Abstand angestrahlt wird.  
**NL** Het apparaat moet zodanig geplaatst worden dat er geen langdurige observatie van het apparaat te voorzien is op een afstand van minder dan 1 m  
**E** El aparato debe emplazarse de manera tal que la observación prolongada se realice a una distancia de al menos 1 m.  
**DK** Apparatet skal placeres på et sted, så der ikke kræves en forlængerledning, der er længere end 1 meter  
**N** Apparatet bør plasseres slik at man ikke behøver å se på det i lengre tid på mindre avstand enn 1 m  
**S** Apparatet ska placeras så att det inte är möjligt att titta in i den under en längre tid på ett avstånd kortare än 1 m  
**RUS** Прибор следует установить так, чтобы не смотреть на него продолжительное время, если расстояние не достигает 1 м.  
**CN** 灯具应按照该种方式安置，以避免长时间在1米范围内盯着灯看。

1.154.653.00  
ISO8370/03

# iGuzzini

SOSTITUZIONE DEL LED  
REPLACING THE LED  
REEMPLACEMENT DE LA LED  
AUSTAUSCHEN DER LED  
VERVANGEN VAN DE LED  
REEMPLAZO DEL LED  
UDSKIFTNING AF LYSDIODE  
BYTE AV LYSDIOD  
UTSKIFTING AV DEN LYSEMITTERENDE DIODEN

ЗАМЕНА СИДа  
发光二极管替换

- I** N.B.: Per la sostituzione del LED contattare l'azienda iGuzzini.  
**GB** N.B.: For information on LED replacement please contact iGuzzini.  
**F** N.B.: Pour procéder au remplacement de la LED, adressez-vous à la société iGuzzini.  
**D** Ñ.B.: Bezüglich des Austausches der LED kontaktieren Sie bitte die Firma iGuzzini.  
**NL** N.B.: Voor het vervangen van de LED neemt u contact op met het bedrijf iGuzzini.  
**E** NOTA: Para sustituir el LED llame a la empresa iGuzzini.  
**DK** N.B.: For udsiftning af lysdioden, skal man kontakte iGuzzini.  
**N** N.B.: For informasjon om skifte av LED, vennligst ta kontakt med iGuzzini.  
**S** OBS! För byte av lysdioden, kontakta företaget iGuzzini.  
**RUS** ПРИМЕЧАНИЕ: Для замены СИДов обращайтесь в компанию iGuzzini.  
**CN** 注意：如需LED更换的信息，请联系iGuzzini。

- I** L'apparecchio dovrebbe essere posizionato in modo che non sia prevista un'osservazione prolungata dell'apparecchio ad una distanza inferiore di 1 m.  
**GB** The luminaire should be positioned so that prolonged staring into the luminaire at a distance closer than 1 m is not expected.  
**FR** Il faudrait placer l'appareil de manière à ce qu'aucune observation prolongée de l'appareil ne soit possible à moins de 1 m de distance  
**D** Das Gerät so positionieren, dass der Anwender nicht über längere Zeit aus weniger als 1 m Abstand angestrahlt wird.  
**NL** Het apparaat moet zodanig geplaatst worden dat er geen langdurige observatie van het apparaat te voorzien is op een afstand van minder dan 1 m  
**E** El aparato debe emplazarse de manera tal que la observación prolongada se realice a una distancia de al menos 1 m.  
**DK** Apparatet skal placeres på et sted, så der ikke kræves en forlængerledning, der er længere end 1 meter  
**N** Apparatet bør plasseres slik at man ikke behøver å se på det i lengre tid på mindre avstand enn 1 m  
**S** Apparatet ska placeras så att det inte är möjligt att titta in i den under en längre tid på ett avstånd kortare än 1 m  
**RUS** Прибор следует установить так, чтобы не смотреть на него продолжительное время, если расстояние не достигает 1 м.  
**CN** 灯具应按照该种方式安置，以避免长时间在1米范围内盯着灯看。

1.154.653.00  
ISO8370/03

# iGuzzini

SOSTITUZIONE DEL LED  
REPLACING THE LED  
REEMPLACEMENT DE LA LED  
AUSTAUSCHEN DER LED  
VERVANGEN VAN DE LED  
REEMPLAZO DEL LED  
UDSKIFTNING AF LYSDIODE  
BYTE AV LYSDIOD  
UTSKIFTING AV DEN LYSEMITTERENDE DIODEN

ЗАМЕНА СИДа  
发光二极管替换

- I** N.B.: Per la sostituzione del LED contattare l'azienda iGuzzini.  
**GB** N.B.: For information on LED replacement please contact iGuzzini.  
**F** N.B.: Pour procéder au remplacement de la LED, adressez-vous à la société iGuzzini.  
**D** Ñ.B.: Bezüglich des Austausches der LED kontaktieren Sie bitte die Firma iGuzzini.  
**NL** N.B.: Voor het vervangen van de LED neemt u contact op met het bedrijf iGuzzini.  
**E** NOTA: Para sustituir el LED llame a la empresa iGuzzini.  
**DK** N.B.: For udsiftning af lysdioden, skal man kontakte iGuzzini.  
**N** N.B.: For informasjon om skifte av LED, vennligst ta kontakt med iGuzzini.  
**S** OBS! För byte av lysdioden, kontakta företaget iGuzzini.  
**RUS** ПРИМЕЧАНИЕ: Для замены СИДов обращайтесь в компанию iGuzzini.  
**CN** 注意：如需LED更换的信息，请联系iGuzzini。

- I** L'apparecchio dovrebbe essere posizionato in modo che non sia prevista un'osservazione prolungata dell'apparecchio ad una distanza inferiore di 1 m.  
**GB** The luminaire should be positioned so that prolonged staring into the luminaire at a distance closer than 1 m is not expected.  
**FR** Il faudrait placer l'appareil de manière à ce qu'aucune observation prolongée de l'appareil ne soit possible à moins de 1 m de distance  
**D** Das Gerät so positionieren, dass der Anwender nicht über längere Zeit aus weniger als 1 m Abstand angestrahlt wird.  
**NL** Het apparaat moet zodanig geplaatst worden dat er geen langdurige observatie van het apparaat te voorzien is op een afstand van minder dan 1 m  
**E** El aparato debe emplazarse de manera tal que la observación prolongada se realice a una distancia de al menos 1 m.  
**DK** Apparatet skal placeres på et sted, så der ikke kræves en forlængerledning, der er længere end 1 meter  
**N** Apparatet bør plasseres slik at man ikke behøver å se på det i lengre tid på mindre avstand enn 1 m  
**S** Apparatet ska placeras så att det inte är möjligt att titta in i den under en längre tid på ett avstånd kortare än 1 m  
**RUS** Прибор следует установить так, чтобы не смотреть на него продолжительное время, если расстояние не достигает 1 м.  
**CN** 灯具应按照该种方式安置，以避免长时间在1米范围内盯着灯看。

I PERIODO GIORNALIERO DI ACCENSIONE AMMESSO  
GB ALLOWED DAILY OPERATION PERIOD  
F DURÉE QUOTIDIENNE D'ALLUMAGE ADMISSIBLE  
D ERLAUBTE TÄGLICHE EINSCHALTDAUER  
NL DAGELIJKSE ONTSTEKINGSPERIODE TOEGESTAAN  
E PERIODO DIARIO DE ENCENDIDO PERMITIDO  
DK TILLADT TIDSRUM FOR DAGLIG TÆNDING  
N TILLÄTT TENNINGSTID PR. DAG  
S TILLÄTEN DAGLIG PERIOD SOM PRODUKTEN KAN VARA TÄND  
RUS ЕЖЕДНЕВНАЯ ДОПУСТИМАЯ ПРОДОЛЖИТЕЛЬНОСТЬ РАБОТЫ  
CN 允许的日常运营周期

iGuzzini

1.154.627.01  
IS09175/01



I PERIODO GIORNALIERO DI ACCENSIONE AMMESSO  
GB ALLOWED DAILY OPERATION PERIOD  
F DURÉE QUOTIDIENNE D'ALLUMAGE ADMISSIBLE  
D ERLAUBTE TÄGLICHE EINSCHALTDAUER  
NL DAGELIJKSE ONTSTEKINGSPERIODE TOEGESTAAN  
E PERIODO DIARIO DE ENCENDIDO PERMITIDO  
DK TILLADT TIDSRUM FOR DAGLIG TÆNDING  
N TILLÄTT TENNINGSTID PR. DAG  
S TILLÄTEN DAGLIG PERIOD SOM PRODUKTEN KAN VARA TÄND  
RUS ЕЖЕДНЕВНАЯ ДОПУСТИМАЯ ПРОДОЛЖИТЕЛЬНОСТЬ РАБОТЫ  
CN 允许的日常运营周期

iGuzzini

1.154.627.01  
IS09175/01



I PERIODO GIORNALIERO DI ACCENSIONE AMMESSO  
GB ALLOWED DAILY OPERATION PERIOD  
F DURÉE QUOTIDIENNE D'ALLUMAGE ADMISSIBLE  
D ERLAUBTE TÄGLICHE EINSCHALTDAUER  
NL DAGELIJKSE ONTSTEKINGSPERIODE TOEGESTAAN  
E PERIODO DIARIO DE ENCENDIDO PERMITIDO  
DK TILLADT TIDSRUM FOR DAGLIG TÆNDING  
N TILLÄTT TENNINGSTID PR. DAG  
S TILLÄTEN DAGLIG PERIOD SOM PRODUKTEN KAN VARA TÄND  
RUS ЕЖЕДНЕВНАЯ ДОПУСТИМАЯ ПРОДОЛЖИТЕЛЬНОСТЬ РАБОТЫ  
CN 允许的日常运营周期

iGuzzini

1.154.627.01  
IS09175/01



I PERIODO GIORNALIERO DI ACCENSIONE AMMESSO  
GB ALLOWED DAILY OPERATION PERIOD  
F DURÉE QUOTIDIENNE D'ALLUMAGE ADMISSIBLE  
D ERLAUBTE TÄGLICHE EINSCHALTDAUER  
NL DAGELIJKSE ONTSTEKINGSPERIODE TOEGESTAAN  
E PERIODO DIARIO DE ENCENDIDO PERMITIDO  
DK TILLADT TIDSRUM FOR DAGLIG TÆNDING  
N TILLÄTT TENNINGSTID PR. DAG  
S TILLÄTEN DAGLIG PERIOD SOM PRODUKTEN KAN VARA TÄND  
RUS ЕЖЕДНЕВНАЯ ДОПУСТИМАЯ ПРОДОЛЖИТЕЛЬНОСТЬ РАБОТЫ  
CN 允许的日常运营周期

iGuzzini

1.154.627.01  
IS09175/01



# iGuzzini

2.507.032.00

**I** Nel serrare il pressacavo, assicurarsi che il gommino "G" non fuoriesca dalla parte opposta della sua sede.

**GB** When tightening the cable-clamp, make sure rubber "G" does not come out on the other side of its housing.  
当拧紧线夹时，请确定橡皮垫圈"G"不会从它所套的另一边伸出来。

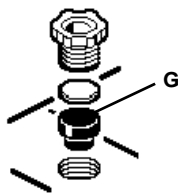

# iGuzzini

2.507.032.00

**I** Nel serrare il pressacavo, assicurarsi che il gommino "G" non fuoriesca dalla parte opposta della sua sede.

**GB** When tightening the cable-clamp, make sure rubber "G" does not come out on the other side of its housing.  
当拧紧线夹时，请确定橡皮垫圈"G"不会从它所套的另一边伸出来。

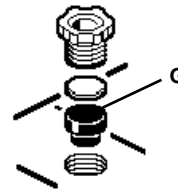

# iGuzzini

2.507.032.00

**I** Nel serrare il pressacavo, assicurarsi che il gommino "G" non fuoriesca dalla parte opposta della sua sede.

**GB** When tightening the cable-clamp, make sure rubber "G" does not come out on the other side of its housing.  
当拧紧线夹时，请确定橡皮垫圈"G"不会从它所套的另一边伸出来。

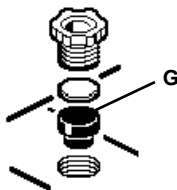

# iGuzzini

2.507.032.00

**I** Nel serrare il pressacavo, assicurarsi che il gommino "G" non fuoriesca dalla parte opposta della sua sede.

**GB** When tightening the cable-clamp, make sure rubber "G" does not come out on the other side of its housing.  
当拧紧线夹时，请确定橡皮垫圈"G"不会从它所套的另一边伸出来。

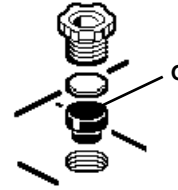

# iGuzzini

2.507.032.00

**I** Nel serrare il pressacavo, assicurarsi che il gommino "G" non fuoriesca dalla parte opposta della sua sede.

**GB** When tightening the cable-clamp, make sure rubber "G" does not come out on the other side of its housing.  
当拧紧线夹时，请确定橡皮垫圈"G"不会从它所套的另一边伸出来。

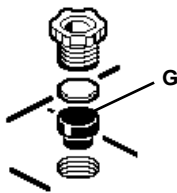

# iGuzzini

2.507.032.00

**I** Nel serrare il pressacavo, assicurarsi che il gommino "G" non fuoriesca dalla parte opposta della sua sede.

**GB** When tightening the cable-clamp, make sure rubber "G" does not come out on the other side of its housing.  
当拧紧线夹时，请确定橡皮垫圈"G"不会从它所套的另一边伸出来。

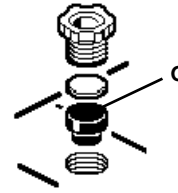

# iGuzzini

2.507.032.00

**I** Nel serrare il pressacavo, assicurarsi che il gommino "G" non fuoriesca dalla parte opposta della sua sede.

**GB** When tightening the cable-clamp, make sure rubber "G" does not come out on the other side of its housing.  
当拧紧线夹时，请确定橡皮垫圈"G"不会从它所套的另一边伸出来。

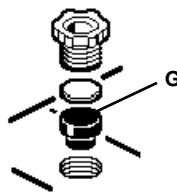

# iGuzzini

2.507.032.00

**I** Nel serrare il pressacavo, assicurarsi che il gommino "G" non fuoriesca dalla parte opposta della sua sede.

**GB** When tightening the cable-clamp, make sure rubber "G" does not come out on the other side of its housing.  
当拧紧线夹时，请确定橡皮垫圈"G"不会从它所套的另一边伸出来。

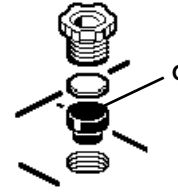





ART.	عامل القدرة fattore di potenza power factor factor de potencia	التيار الممتص corrente assorbita absorbed current corriente absorbida (A)
BD32 - BD33	> 0,9	0,125
BD38	> 0,95	0,210
BD39 - BD50	1	-
BD40 - BD41 - BD42 - BD43 - BI37	> 0,95	0,200
BD44 - BD45	> 0,9	0,230
BD51 - BI35	0,6	0,140
BD52 - BD53 - BD54 - BD55 - BD56 - BL26	> 0,95	0,350
BD57 - BD58	> 0,9	0,420
BD59 - BD61 - BL27	> 0,9	0,800
BG35 - BG36 - BG37 - BG38 - BI38 - BI39 - BI40 - BL22 BL23 - BL24 - BD34 - BD35 - BD36 - BD37 - BD46 - BD47 BD48 - BD49 - BI31 - BI32 - BI33 - BI34	0,9	> 0,15
BI36	0,95	> 0,11
BL25	0,93	> 0,12

ART.	عامل القدرة fattore di potenza power factor factor de potencia	التيار الممتص corrente assorbita absorbed current corriente absorbida (A)
BD32 - BD33	> 0,9	0,125
BD38	> 0,95	0,210
BD39 - BD50	1	-
BD40 - BD41 - BD42 - BD43 - BI37	> 0,95	0,200
BD44 - BD45	> 0,9	0,230
BD51 - BI35	0,6	0,140
BD52 - BD53 - BD54 - BD55 - BD56 - BL26	> 0,95	0,350
BD57 - BD58	> 0,9	0,420
BD59 - BD61 - BL27	> 0,9	0,800
BG35 - BG36 - BG37 - BG38 - BI38 - BI39 - BI40 - BL22 BL23 - BL24 - BD34 - BD35 - BD36 - BD37 - BD46 - BD47 BD48 - BD49 - BI31 - BI32 - BI33 - BI34	0,9	> 0,15
BI36	0,95	> 0,11
BL25	0,93	> 0,12

iGuzzini

2.509.386.00  
ISO9176/01

الفترة الزمنية اليومية للتشغيل المسموح بها

- I PERIODO GIORNALIERO DI ACCENSIONE AMMESSO
- GB ALLOWED DAILY OPERATION PERIOD
- E PERIODO DIARIO DE ENCENDIDO PERMITIDO

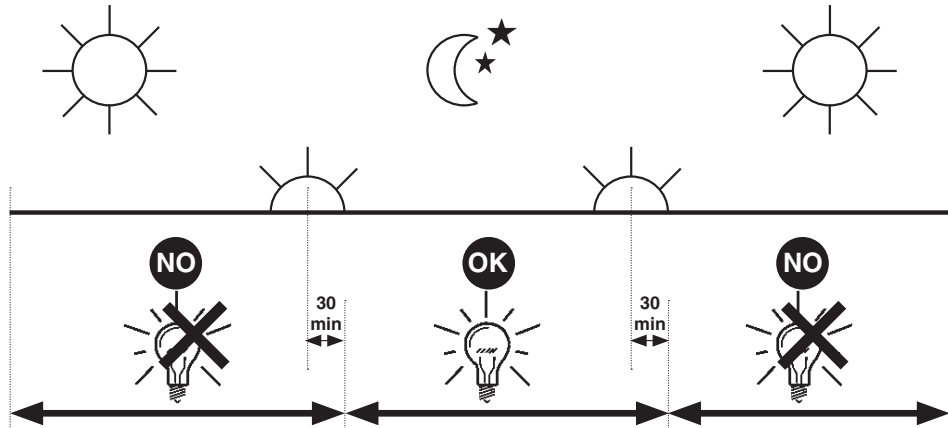

iGuzzini

2.509.386.00  
ISO9176/01

الفترة الزمنية اليومية للتشغيل المسموح بها

- I PERIODO GIORNALIERO DI ACCENSIONE AMMESSO
- GB ALLOWED DAILY OPERATION PERIOD
- E PERIODO DIARIO DE ENCENDIDO PERMITIDO

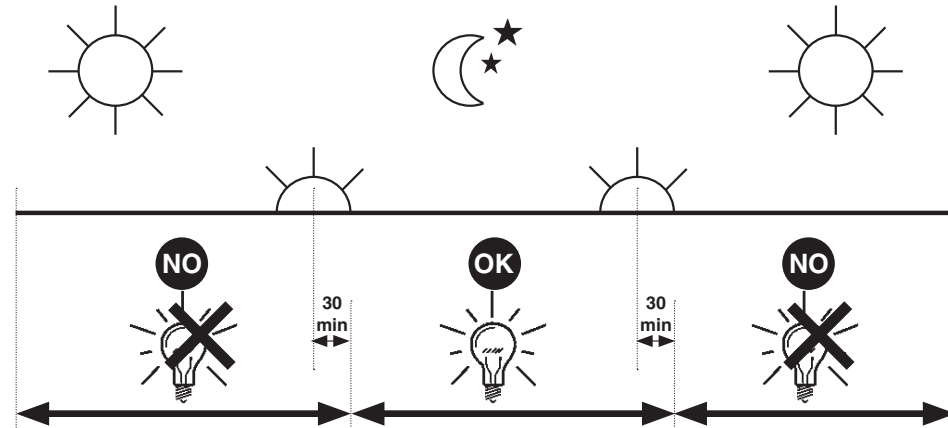

iGuzzini

2.509.386.00  
ISO9176/01

الفترة الزمنية اليومية للتشغيل المسموح بها

- I PERIODO GIORNALIERO DI ACCENSIONE AMMESSO
- GB ALLOWED DAILY OPERATION PERIOD
- E PERIODO DIARIO DE ENCENDIDO PERMITIDO

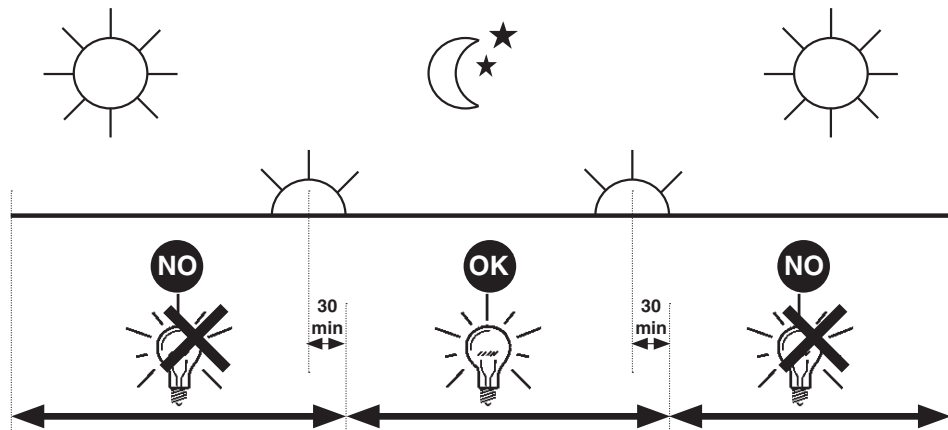

iGuzzini

2.509.386.00  
ISO9176/01

الفترة الزمنية اليومية للتشغيل المسموح بها

- I PERIODO GIORNALIERO DI ACCENSIONE AMMESSO
- GB ALLOWED DAILY OPERATION PERIOD
- E PERIODO DIARIO DE ENCENDIDO PERMITIDO

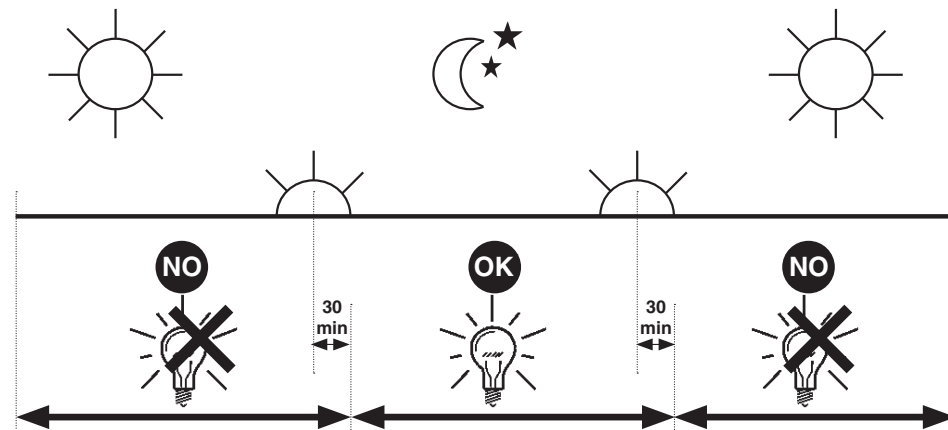

2.509.417.01  
ISO9496/01

# iGuzzini

استبدال الضوء LED  
SOSTITUZIONE DEL LED  
REPLACING THE LED  
REEMPLAZO DEL LED

ملاحظة: لاستبدال الضوء، اتصل بشركة iGuzzini

I N.B.: Per la sostituzione del LED contattare l'azienda iGuzzini.

GB N.B.: For information on LED replacement please contact iGuzzini.

E NOTA: Para sustituir el LED llame a la empresa iGuzzini.

تفاسم نم، ءليوط قرتفل زاهجلا تبقارم عقوت مدع رابتعالا  
نيعب ذخوي ثيحب، زاهجلا عضو بجي رتم 1 نم لقا

I L'apparecchio dovrebbe essere posizionato in modo che non sia prevista un'osservazione prolungata dell'apparecchio ad una distanza inferiore di 1 m.

GB The luminaire should be positioned so that prolonged staring into the luminaire at a distance closer than 1 m is not expected.

E El aparato debe emplazarse de manera tal que la observación prolongada se realice a una distancia de al menos 1 m.

2.509.417.01  
ISO9496/01

# iGuzzini

استبدال الضوء LED  
SOSTITUZIONE DEL LED  
REPLACING THE LED  
REEMPLAZO DEL LED

ملاحظة: لاستبدال الضوء، اتصل بشركة iGuzzini

I N.B.: Per la sostituzione del LED contattare l'azienda iGuzzini.

GB N.B.: For information on LED replacement please contact iGuzzini.

E NOTA: Para sustituir el LED llame a la empresa iGuzzini.

تفاسم نم، ءليوط قرتفل زاهجلا تبقارم عقوت مدع رابتعالا  
نيعب ذخوي ثيحب، زاهجلا عضو بجي رتم 1 نم لقا

I L'apparecchio dovrebbe essere posizionato in modo che non sia prevista un'osservazione prolungata dell'apparecchio ad una distanza inferiore di 1 m.

GB The luminaire should be positioned so that prolonged staring into the luminaire at a distance closer than 1 m is not expected.

E El aparato debe emplazarse de manera tal que la observación prolongada se realice a una distancia de al menos 1 m.

2.509.417.01  
ISO9496/01

# iGuzzini

استبدال الضوء LED  
SOSTITUZIONE DEL LED  
REPLACING THE LED  
REEMPLAZO DEL LED

ملاحظة: لاستبدال الضوء، اتصل بشركة iGuzzini

I N.B.: Per la sostituzione del LED contattare l'azienda iGuzzini.

GB N.B.: For information on LED replacement please contact iGuzzini.

E NOTA: Para sustituir el LED llame a la empresa iGuzzini.

تفاسم نم، ءليوط قرتفل زاهجلا تبقارم عقوت مدع رابتعالا  
نيعب ذخوي ثيحب، زاهجلا عضو بجي رتم 1 نم لقا

I L'apparecchio dovrebbe essere posizionato in modo che non sia prevista un'osservazione prolungata dell'apparecchio ad una distanza inferiore di 1 m.

GB The luminaire should be positioned so that prolonged staring into the luminaire at a distance closer than 1 m is not expected.

E El aparato debe emplazarse de manera tal que la observación prolongada se realice a una distancia de al menos 1 m.

2.509.417.01  
ISO9496/01

# iGuzzini

استبدال الضوء LED  
SOSTITUZIONE DEL LED  
REPLACING THE LED  
REEMPLAZO DEL LED

ملاحظة: لاستبدال الضوء، اتصل بشركة iGuzzini

I N.B.: Per la sostituzione del LED contattare l'azienda iGuzzini.

GB N.B.: For information on LED replacement please contact iGuzzini.

E NOTA: Para sustituir el LED llame a la empresa iGuzzini.

تفاسم نم، ءليوط قرتفل زاهجلا تبقارم عقوت مدع رابتعالا  
نيعب ذخوي ثيحب، زاهجلا عضو بجي رتم 1 نم لقا

I L'apparecchio dovrebbe essere posizionato in modo che non sia prevista un'osservazione prolungata dell'apparecchio ad una distanza inferiore di 1 m.

GB The luminaire should be positioned so that prolonged staring into the luminaire at a distance closer than 1 m is not expected.

E El aparato debe emplazarse de manera tal que la observación prolongada se realice a una distancia de al menos 1 m.

- I Istruzioni per le operazioni di servizio per l'apparecchio di illuminazione**  
**GB Instructions on luminaire service operations**  
**F Instructions pour les opérations de service du luminaire**  
**D Wartungsanleitung für die Leuchte**  
**NL Instructies voor de onderhoudsoperaties op de verlichtingsarmatuur**  
**E Instrucciones para las operaciones de servicio del aparato de alumbrado**  
**DK Anvisninger i serviceindgreb på belysningsarmatur**  
**N Anvisninger for betjening av lysapparatet**  
**S Instruktioner för användning av belysningsanordningen**  
**RUS Инструкции по эксплуатации осветительного прибора**  
**CN 照明装置检修操作说明**

**Sostituire la lampada parzialmente esausta**  
 Replace the partly exhausted lamp  
 Remplacer la lampe partiellement épuisée  
 Die teilweise erschöpfte Lampe austauschen  
 Vervang de gedeeltelijk lege lamp  
 Sustituir la lámpara parzialmente agotada  
 Udskift den delvist udtjente pære  
 Skifte ut den delvis utbrente lyspæren  
 Byt ut den delvis förbrukade lampan  
 Замена частично отработанной лампочки  
 更换部分老化的灯泡



**Spegnimento**  
 Switch it off  
 Extinction  
 Ausschaltung  
 Uitschakeling  
 Apagado  
 Slukning  
 Slukking  
 Släckning  
 Выключение  
 关灯

**Interrompere l'alimentazione dell'apparecchio**  
 Cut the power supply to the luminaire  
 Couper l'alimentation du luminaire  
 Stromversorgung der Leuchte unterbrechen  
 Onderbreek de voeding van het apparaat  
 Interrumpir la alimentación del aparato  
 Afbryd armaturets strømforsyning  
 Avbryte strømtilførselen til apparatet  
 Koppla från anordningens strömförsörjning  
 Отключить электропитание прибора  
 中断装置供电

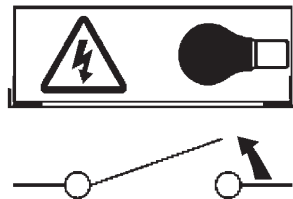

**Aprire l'apparecchio**  
 Open the fixture  
 Ouvrir le luminaire  
 Das Gerät öffnen  
 Open het apparaat  
 Abrir el aparato  
 Åbn armaturet  
 Åpne apparatet  
 Öppna anordningen  
 Раскрыть прибор  
 打开装置

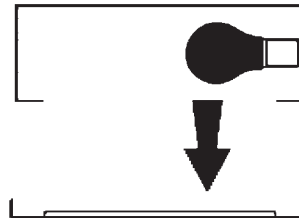

**Rimuovere la lampada esausta**  
 Remove the exhausted lamp  
 Retirer la lampe épuisée  
 Die alte Lampe entnehmen  
 Verwijder de lege lamp  
 Quitar la lámpara agotada  
 Tag den udtjente pære ud  
 Fjerne den utbrente lyspæren  
 Ta bort den förbrukade lampan  
 Вынуть старую лампочку  
 取出老化的灯泡

**Portarla in un centro di riciclaggio**  
 Carry it to a recycling centre  
 La porter dans une déchetterie pour son recyclage  
 Ordnungsgemäß entsorgen  
 Breng de lamp naar een recyclingcentrum  
 Llevarla a un centro de reciclaje  
 Aflever den på en genbrugsstation  
 Lever den til en miljøstasjon  
 Lämna in den till en återvinningsanläggning  
 Сдать ее в пункт приема утильсырья  
 将其送往回收中心



**Inserire la nuova lampada**  
 Introduce the new lamp  
 Installer la lampe neuve  
 Die neue Lampe einsetzen  
 Doe de nieuwe lamp op zijn plek  
 Montar la nueva lámpara  
 Sæt den nye pære i  
 Sette i den nye pæren  
 Sätt i den nya lampan  
 Вставить новую лампочку  
 装入新灯泡

**Inserire la nuova lampada nel portalampada**  
 Fit the new lamp into the socket  
 Installer la nouvelle lampe dans le support de lampe  
 Die neue Lampe in den Sockel einsetzen  
 Doe de nieuwe lamp in de lamphouder  
 Montar la nueva lámpara en el portalámpara  
 Sæt den nye pære i fatningen  
 Sette den nye pæren inn i lampeholderen  
 Sätt i den nya lampan i lamphållaren  
 Вставить новую лампочку в патрон  
 将新灯泡插入灯泡架中



**Riposizionare ottica**  
 Re-place the optic  
 Remettre l'optique à sa place  
 Die Optik wieder einsetzen  
 Doe de optiek weer op zijn plaats  
 Volver a montar la óptica  
 Sæt den optiske enhed på plads  
 Innstille linsen  
 Flytta om optiken  
 Отрегулировать линзы  
 重新定位光头

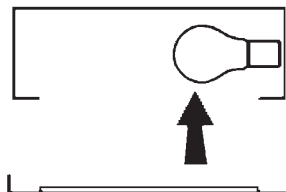

**Effettuare prova di funzionamento**  
 Perform operative test  
 Procéder à un essai de fonctionnement  
 Eine Funktionsprüfung durchführen  
 Controleer de correcte werking  
 Hacer una prueba de funcionamiento  
 Afprøv funktionen  
 Prøve om den fungerer  
 Utför funktionstest  
 Выполнить проверку исправности работы  
 执行功能测试

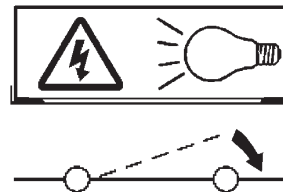

**I Istruzioni per la pulizia dell'apparecchio di illuminazione**  
**GB Instructions on luminaire cleaning operations**  
**F Instructions pour le nettoyage du luminaire**  
**D Anweisungen zur Reinigung der Leuchte**  
**NL Instructies voor de reiniging van de verlichtingsarmatuur**  
**E Instrucciones para limpiar el aparato de alumbrado**  
**DK Anvisninger i rengøring af belysningsarmaturet**  
**N Anvisninger for rengjøring av lysapparatet**  
**S Instruktioner för rengöring av belysningsanordningen**  
**RUS Инструкции по чистке осветительного прибора**  
**CN 照明装置清洁说明**

**Pulire l'apparecchio**  
 Clean the fixture  
**Nettoyer le luminaire**  
 Das Gerät reinigen  
**Reinig het apparaat**  
 Limpiar el aparato  
**Rengør armaturet**  
**Rengjøre apparatet**  
**Rengör anordningen**  
 Чистка прибора  
 清洁装置

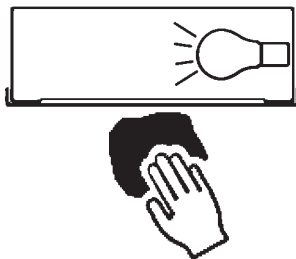

**Spegnimento**  
 Switch it off  
**Extinction**  
**Ausschaltung**  
**Uitschakeling**  
**Apagado**  
**Slukning**  
**Slukking**  
**Släckning**  
**Выключение**  
 关灯

Interrompere l'alimentazione dell'apparecchio  
 Cut the power supply to the luminaire  
 Couper l'alimentation du luminaire  
 Stromversorgung der Leuchte unterbrechen  
 Onderbreek de voeding van het apparaat  
 Interrumpir la alimentación del aparato  
 Afbryd armaturets strømforstyrning  
 Avbryt strømtilførselen til apparatet  
 Koppla från anordningens strömförsörjning  
 Отключить электропитание прибора  
 中断装置供电



**Spolverare l'ottica esterna**  
 Remove dust from the external optic  
**Dépoussiérer l'optique extérieure**  
**Die externe Optik abstauben**  
**Stof de externe optiek af**  
**Quitar el polvo de la óptica exterior**  
**Tør støvet af den udvendige optiske enhed**  
**Fjerne støv fra den eksterne lysenheten**  
**Damma av den yttre optiken**  
**Вытереть пыль с внешней стороны линз**  
 为外侧光头掸尘

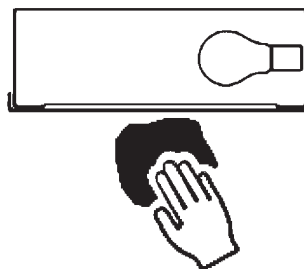

**Lavare l'ottica esterna**  
 Wash the external optic  
**Laver l'optique extérieure**  
**Die externe Optik waschen**  
**Was de externe optiek**  
**Lavar la óptica exterior**  
**Vask den udvendige optiske enhed**  
**Vaske den eksterne lysenheten**  
**Rengör den yttre optiken**  
**Вымыть линзы с внешней стороны**  
 清洁外光头



**Rimuovere l'ottica**  
 Remove the optic  
**Retirer l'optique**  
**Die Optik abnehmen**  
**Verwijder de optiek**  
**Quitar la óptica**  
**Tag den optiske enhed af**  
**Fjerne lysenheten**  
**Ta bort optiken**  
**Снять линзы**  
 取下光头



**Pulire la parte interna dell'apparecchio di illuminazione**  
 Clean the inside of the fixture  
**Nettoyer l'intérieur du luminaire**  
**Die Innenseite der Leuchte reinigen**  
**Reinig de binnenzijde van de verlichtingsarmatuur**  
**Limpiar el interior del aparato de alumbrado**  
**Rengør belysningsarmaturets indvendige dele**  
**Rengjøre lysapparatet innvendig**  
**Rengör belysningsanordningen invändigt**  
**Протереть осветительный прибор изнутри**  
 清洁照明装置内部

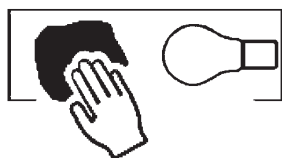

**Riposizionare ottica**  
 Re-place the optic  
**Remettre l'optique à sa place**  
**Die Optik wieder einsetzen**  
**Doe de optiek weer op zijn plaats**  
**Volver a montar la óptica**  
**Sæt den optiske enhed på plads**  
**Innstille linsen**  
**Flytta om optiken**  
**Отрегулировать линзы**  
 重新定位光头



**Effettuare prova di funzionamento**  
 Perform operative test  
**Procéder à un essai de fonctionnement**  
**Eine Funktionsprüfung durchführen**  
**Controleer de correcte werking**  
**Hacer una prueba de funcionamiento**  
**Afprøv funktionen**  
**Prøve om den fungerer**  
**Utför funktionstest**  
**Выполнить проверку исправности работы**  
 执行功能测试

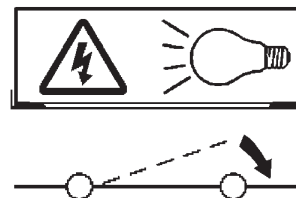

- I** Istruzioni per il fine vita e lo smaltimento dei componenti  
**GB** Instructions on end-of-life and component disposal  
**F** Instructions pour la gestion des composants en fin de vie et leur mise au rebut  
**D** Anweisungen zur Entsorgung der Leuchtenkomponenten  
**NL** Instructies voor het verwijderen van de armatuur en het recyclen van de onderdelen  
**E** Instrucciones para el final de vida y la eliminación los componentes  
**DK** Anvisninger i udtjent armatur og bortskaffelse af komponenter  
**N** Anvisninger for endt levetid og avfallsbehandling av delene  
**S** Instruktioner vid bortskaffning och kassering av komponenter  
**RUS** Инструкции по утилизации прибора и его комплектующих по окончании его срока службы  
**CN** 寿命期结束与零件废弃处置说明

<p>Spegnimento Switch it off Extinction Ausschaltung Uitschakeling Apagado Slukning Slukking Släckning Выключение 关灯</p> <p>Interrompere l'alimentazione dell'apparecchio Cut the power supply to the luminaire Couper l'alimentation du luminaire Stromversorgung der Leuchte unterbrechen Onderbreek de voeding van het apparaat Interrompirla alimentación del aparato Afbryd armaturets strømforsyning Avbryt strømtilførselen til apparatet Koppla från anordningens strömförsörjning Отключить электропитание прибора 中断装置供电</p> 	<p>Rimuovere la/e lampada/e per la dismissione Remove the lamp(s) for decommissioning Retirer la(les) lampe(s) pour sa(leur) mise au rebut Die Lampe/n ordnungsgemäß entsorgen Verwijder de lamp(en) voor het recyclen Quitar la(s) lámpara(s) para el desecho Tag pæren/pærerne ud til bortskaffelse Fjerne lampen/-e som skal kastes Ta bort lampan/-orna för bortskaffningen Вынуть лампочку/и для утилизации прибора 取出需要丢弃的灯泡</p> 	<p>Rimuovere la batteria per la dismissione Remove the battery for decommissioning Retirer la batterie pour sa mise au rebut Die Batterie ordnungsgemäß entsorgen Verwijder de batterij voor het recyclen Quitar la batería para el desecho Tag batteriet ud til bortskaffelse Fjerne batteriet som skal kastes Ta bort batteriet för bortskaffningen Вынуть батарейку для утилизации прибора 取出需要丢弃的电池</p> 	<p>Rimuovere l'apparecchio per la dismissione Remove the fixture for decommissioning Enlever le luminaire pour sa mise au rebut Das Gerät ordnungsgemäß entsorgen Verwijder het apparaat voor het recyclen Quitar el aparato para el desecho Tag armaturet ud til bortskaffelse Fjerne apparatet som skal kastes Ta bort anordningen för bortskaffningen Снять прибор для утилизации 取出需要丢弃的装置</p> 
---	--	--	--

<p>Inviare i materiali ad un centro di raccolta RAEE Send the materials to a WEEE collection centre Envoyer les matériaux dans une déchetterie DEEE Die Materialien in einem WEEE-Zentrum entsorgen Zend de materialen naar een recyclingscentrum voor de AEEA Enviar los materiales a un centro de recogida RAEE Afløver materialerne på et indsamlingscenter for elektronisk udstyr Sende materialene til en miljøstasjon for resirkulering av EE-avfall Skicka materialet till en RAEE uppsamlingscentral Сдать материалы в пункт приема утильсырья 将材料送往电气和电子垃圾回收中心</p> 			
--	--	--	--