

518012

Product Sheet

ares
THE OUTDOOR BY FLOS

ARES s.r.l - Socio Unico
v.le dell'Artigianato n.24 - 20881 Bernareggio - MB (Italy)
www.aresill.net - flos.outdoor@flos.com

Sigma

Round luminaire for installation on wall, ceiling or ground - recessed. Configuration: turned aluminium body (EN AW-6060 alloy) with 15 micron anodizing for high resistance to corrosion. AISI 316L or aluminium cap, open frame and cover (see the catalogue pages for reference). Diffuser: polycarbonate or methacrylate transparent or sandblasted (see the catalogue pages for reference). Double layer coating for high resistance to corrosion: the aluminium components are painted with a double coat using powders which are compliant with QUALICOAT standards: a first layer of epoxy powder (with excellent chemical and mechanical resistance) and a second finishing layer of polyester powder (resistant to UV rays and atmospheric agents). The entire painting process of the aluminium fitting starts from components which have been sandblasted in advance to make the surface more porous and increase the adherence of the paint. Ares effects alkaline and acid washing to clean the surfaces completely, then rinses with demineralised water to remove any residue particles, subsequently a chemical conversion treatment is done to protect against rusting. Protection rating: IP67 In compliance with EN 60598-1 standards Class of insulation: III Installation: the luminaire is equipped with a piece of cable for an easy-to-make connection. In-ground version: the cable is integrated with an H2O STOP device. Sigma is equipped with a dc/dc highly efficient resin-coated converter that removes electromagnetic interference and is protected against polarity reversal and sudden voltage peak. Outdoor use requires suitable flexible cables. Installation in solid surfaces requires a dedicated box for installation to be purchased separately, installation in panels is only possible with the version with springs. It is important to provide for the in-ground version a >200mm gravel layer or a drain system (for concrete surfaces) to ensure good drainage and to avoid water stagnation. Parallel wiring We recommend the use of a connection system with a protection degree greater than or equal to the protection degree of the luminaire.

Sigma Power LED / 316L Stainless Steel Frame - Medium Beam 30°

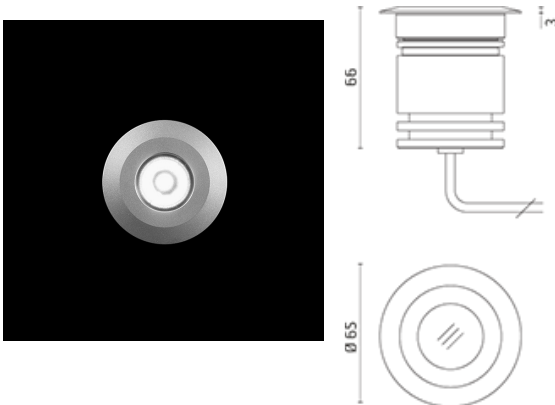

Product Code Details

518012

Light Source



NATURAL WHITE 4000K POWER LED 2,2W/24Vdc
Total power 3,4W
LED lm 198 ÷ OUTPUT lm 125
CRI >80
Remote electronic power supply to be ordered



IP67

Available Colors for this Version

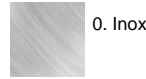

Warnings

Wall Recessed

- Protection against impact. IK 06 - 1,00 joule (version with frame) IK 08 - 5,00 joule (version with cover)
- Recessed wall fitting
- Pre-wired with approx 200mm of cable
- Remote device required
- Glow wire test: 850°C

Ground Recessed

- Recessed ground fitting
- Do not install in hollow areas
- Installation requires a 20 cm water drainage layer (gravel)
- Protection against water ingress from the cable. (only for in-ground recessed versions)
- Static load: 500Kg walk over (version with frame) Static load: 2000Kg walk over (version with cover)
- Protection against impact. IK 06 - 1,00 joule (version with frame) IK 08 - 5,00 joule (version with cover)
- Pre-wired with approx 200mm of cable
- Remote device required
- Glass surface temperature
- Glow wire test: 850°C

Light Flux, Placement



Accessories



Code: 170
Box for installation
Ø 105 H 78 mm
For in-ground installation or concrete wall



Code: 150
Supported n. of lamps: 1
Power supply dual function
Vout 24Vdc: 8W/100÷240V
Iout 350mA: 6X1W/100÷240V
IP20 CLASS II SELV EQ.



Code: 106
Supported n. of lamps: 1
Power supply dual function
Vout 24Vdc: 8W/100÷240V
Iout 350mA: 6X1W/100÷240V - IP65 CLASS II SELV EQ.



Code: 87
Supported n. of lamps: 2
Power supply
10W/110÷240V - 24Vdc
IP20 CLASS II SELV.



Code: 175
Supported n. of lamps: 2
Power supply
10W/110÷240V - 24Vdc
IP67 CLASS II SELV.



Code: 147
Supported n. of lamps: 3
Power supply
20W/220÷240V - 24Vdc
IP67 CLASS II SELV.



Code: 155
Supported n. of lamps: 9
Power supply
50W/120÷240V - 24Vdc
IP67 CLASS II SELV.



Code: 110
Supported n. of lamps: 17
Power supply
70W/220÷240V - 24Vdc
IP67 CLASS II SELV EQ.