

## DASAR HQI SQUARE 70W recessed fitting

asymmetrical, stainl. steel 316, Rx7s, max. 70W

Article number	229294
Catalogue	BIG WHITE 2015, Page 678
Type of lamp	Conventional lamp
Lamp	HQI-TS / CDM-TD 70W
Lampholder / Socket	Rx7s
Number of light sources	1
Lamp included	No
Installation length	24.5 cm
Installation width	24.5 cm
Installation depth	17.5 cm
Length	25.5 cm
Width	25.5 cm
Height	15.5 cm
Net weight	7.53 kg
Gross weight	9.408 kg
Voltage	230 Volt
Max. wattage	70 Watt
Protection class	I
Material	aluminium / stainless steel 316
Colour	stainless steel
Way of mounting	recessed ground mounting
Remark 1	Conventional ballast incorporated. Mounting plot included
Remark 2	Weight capacity 2 tons. Asymmetrical reflector
Remark 3	Maximum cable diameter 9 - 12 mm
Remark 4	Energy labels in your language are available in the Service Area sub point Download
Energy class ballast	A3
Suitable for lamps from EEC	A
Suitable for lamps up to EEC	A+

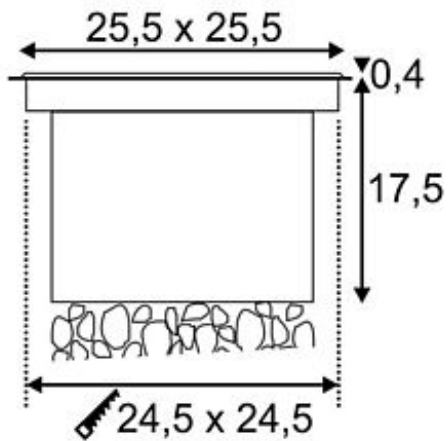

Light distribution  
type 1      direct

Light distribution  
type 3      asymmetric

The walkable recessed ground luminaire with a round stainless steel cover and partially satined glass is equipped with an adjustable Rx7s lampholder and a suitable ballast making it compatible with discharge lamps. Due to the integrated asymmetric reflector, a homogeneous and planar illumination is possible even with small distances to the illuminated surface. Rated IP67, DASAR is suitable for outdoor use. The electrical connection is made directly to 230V mains supply. For simplified mounting, a suitable installation housing is included. This luminaire is compatible with bulbs of the energy classes: A - A+