

## ADJUST HQI 70 recessed ground luminaire

round, stainless steel 304, G12, max. 70W, IP67

Article number	228240
Catalogue	BIG WHITE 2015, Page 679
Type of lamp	Conventional lamp
Lamp	HQI-T / CDM-T 70W
Lampholder / Socket	G12
Number of light sources	1
Lamp included	No
Installation diameter	26 cm
Installation depth	22 cm
Tilt range	15 Degree
Diameter	26.5 cm
Net weight	5.082 kg
Gross weight	1.269 kg
Voltage	230 Volt
Max. wattage	70 Watt
Protection class	I
Beam angle	35 Degree
Material	aluminium / stainless steel 304
Colour	stainless steel
Way of mounting	recessed ground mounting
Remark 1	Maximum cable diameter 12 mm
Remark 2	Weigth capacity 5 tons. Through-wiring is possible
Remark 3	Conventional ballast included
Remark 4	Energy labels in your language are available in the Service Area sub point Download
Energy class ballast	A3
Suitable for lamps from EEC	A
Suitable for lamps up to EEC	A+
Light distribution type 1	direct

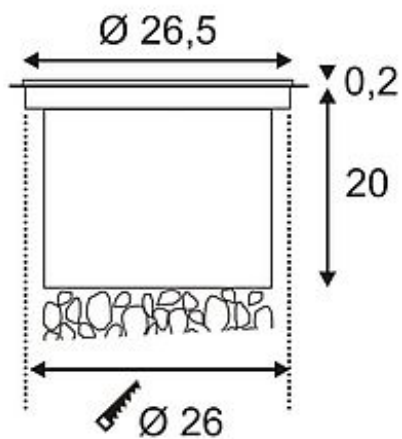

Light distribution type 3      rotationally symmetric

The walkable high-voltage floor luminaire with a round stainless steel cover and partially satined glass is equipped with an adjustable G12 lampholder making it compatible with discharge lamps. Rated IP67 it is suitable for outdoor use. The electrical connection is made directly to 230V mains supply via the incorporated ballast. For simplified mounting, a suitable installation housing is included. Through-wiring is possible. This luminaire is compatible with bulbs of the energy classes: A - A+