

BOOST B IP44 downlight

round, white, 13W LED, warmwhite

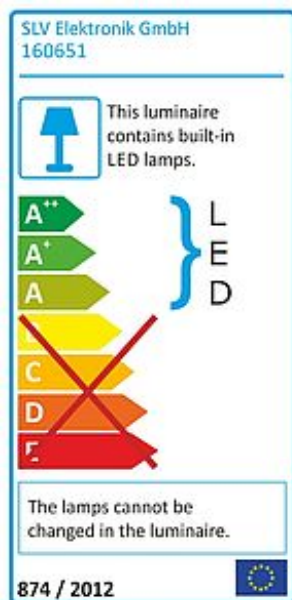

Article number	160651
Catalogue	BIG WHITE 2015, Page 410
Type of lamp	LED lamp
Lamp	planar LED 13W
Number of light sources	1
Lamp included	Yes
Installation diameter	12 cm
Installation depth	13.5 cm
Height	13.7 cm
Diameter	13.2 cm
Net weight	0.43 kg
Gross weight	0.655 kg
Max. wattage	13 Watt
Protection class	III
Beam angle	35 Degree
Material	aluminium / plastic
Colour	white
Way of mounting	recessed ceiling mounting
Remark 1	For recessed installation in ceilings with a maximum thickness of 20 mm
Remark 2	Operate with suitable 350 mA drivers only
Remark 3	Energy labels in your language are available in the Service Area sub point Download
Average lifespan	40000 Hours
Colour temperature	3000 Kelvin
Colour rendering index	>80
Luminous flux	1000 lm
Suitable for lamps from EEC	A
Suitable for lamps up to EEC	A++
Light distribution type 1	direct

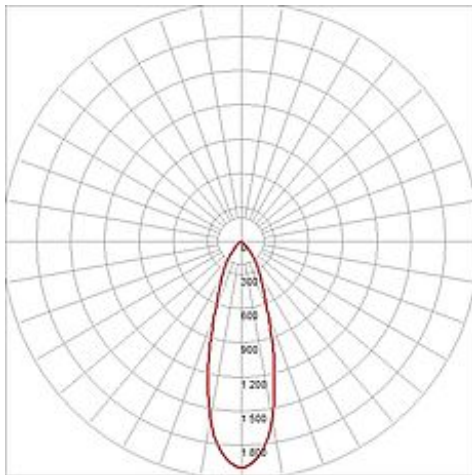
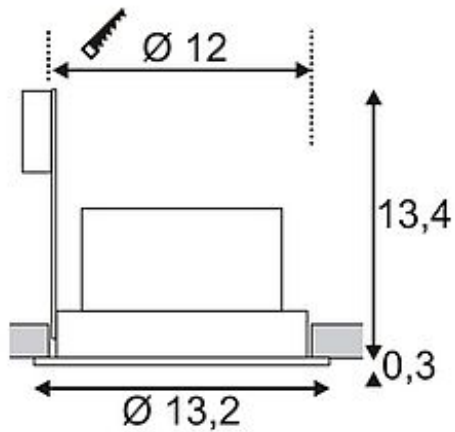

Light distribution rotationally symmetric
type 3

The rigid LED recessed downlight BOOST B IP44 is made from aluminum and is the LED lighting solution for the exchange of high-intense halogen or incandescent lamps. The incorporated and warmwhite 13W Power LED provides the desired illumination intensity. Rated IP44 it can also be used in damp rooms. Available in either white or silvergrey colour version, a suitable constant current driver providing 350mA is required to operate the fitting. This luminaire contains built-in LED lamps. EEK: A - A++. The lamps cannot be changed in the luminaire.