

BOOST B TURNO downlight

adjustable, round, white, 13W LED, warmwhite

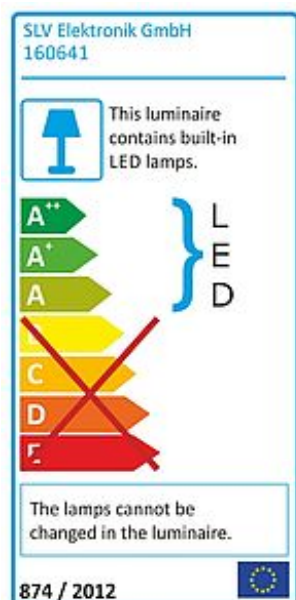

| | |
|------------------------------|---|
| Article number | 160641 |
| Catalogue | BIG WHITE 2015, Page 410 |
| Type of lamp | LED lamp |
| Lamp | planar LED 13W |
| Number of light sources | 1 |
| Lamp included | Yes |
| Installation diameter | 12 cm |
| Installation depth | 13.3 cm |
| Tilt range | 17 Degree |
| Height | 13.5 cm |
| Diameter | 13.3 cm |
| Net weight | 0.476 kg |
| Gross weight | 0.334 kg |
| Max. wattage | 13 Watt |
| Protection class | III |
| Beam angle | 35 Degree |
| Material | aluminium / plastic |
| Colour | white |
| Way of mounting | recessed ceiling mounting |
| Remark 1 | For recessed installation in ceilings with a maximum thickness of 15 mm |
| Remark 2 | Operate with suitable 350 mA drivers only |
| Remark 3 | Energy labels in your language are available in the Service Area sub point Download |
| Average lifespan | 40000 Hours |
| Colour temperature | 3000 Kelvin |
| Colour rendering index | >80 |
| Luminous flux | 1000 lm |
| Suitable for lamps from EEC | A |
| Suitable for lamps up to EEC | A++ |

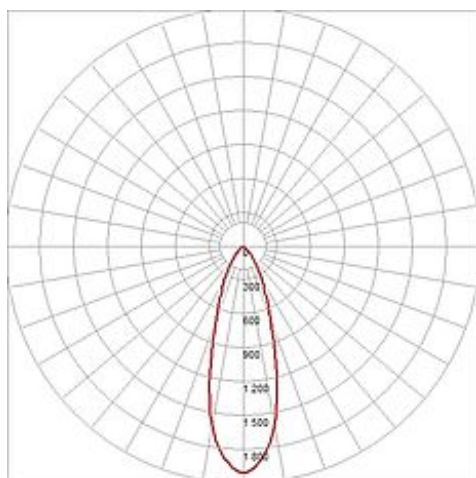
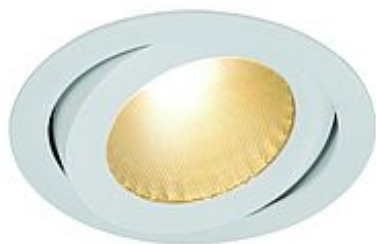
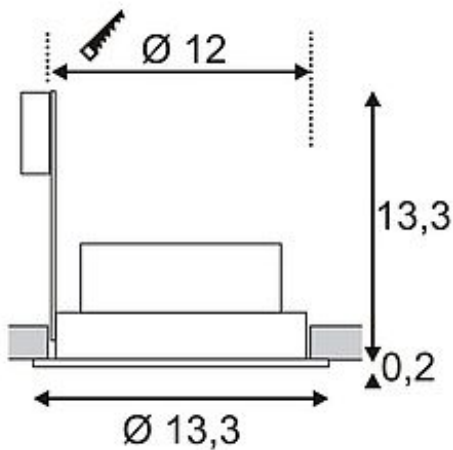

Light distribution
type 1 direct

Light distribution
type 3 rotationally symmetric

The rigid LED recessed downlight BOOST B TURNO is made from aluminum and is the LED lighting solution for the exchange of high-intense halogen or incandescent lamps. The incorporated and warmwhite 13W Power LED provides the desired illumination intensity. Available in either white or silvergrey colour version, a suitable constant current driver providing 350mA is required to operate the fitting. This luminaire contains built-in LED lamps. EEK: A - A++. The lamps cannot be changed in the luminaire.