

LUZO INTEGRATED LED

recessed ring, round, white, 4000K, 13W , 13W, 36°

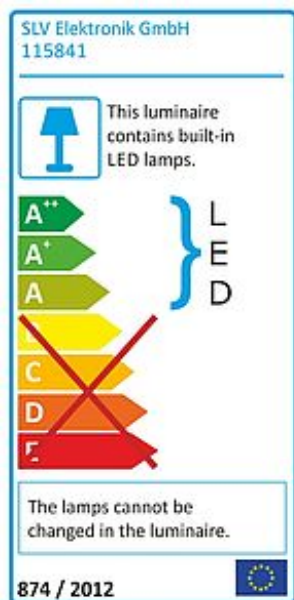

Article number	115841
Catalogue	BIG WHITE 2015, Page 409
Type of lamp	LED lamp
Lamp	Philips Fortimo LED Integrated Spot-Module
Number of light sources	1
Lamp included	Yes
Installation diameter	10.2 cm
Installation depth	12.5 cm
Height	13 cm
Diameter	11.5 cm
Net weight	0.549 kg
Gross weight	0.631 kg
Voltage	230 Volt
Max. wattage	12.6 Watt
Protection class	I
Beam angle	36 Degree
Material	aluminium
Colour	white
Way of mounting	recessed ceiling mounting
Remark 1	For recessed installation in ceilings with a maximum thickness of 25 mm
Remark 2	Equipped with the Fortimo LED integrated spot module of Philips
Remark 3	Energy labels in your language are available in the Service Area sub point Download
Average lifespan	50000 Hours
Colour temperature	4000 Kelvin
Colour rendering index	80
Luminous flux	640 lm
Suitable for lamps from EEC	A
Suitable for lamps up to EEC	A++

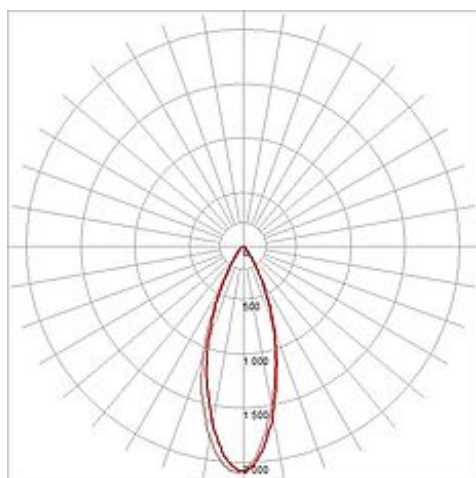
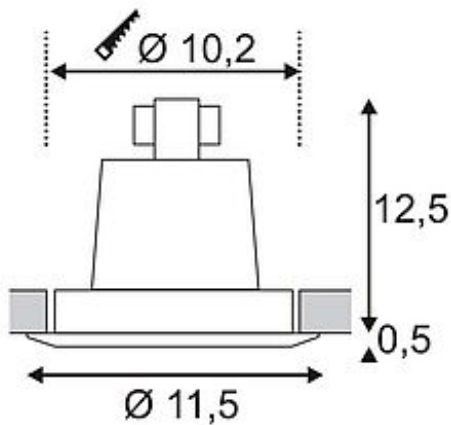

Light distribution
type 1 direct

Light distribution
type 3 rotationally symmetric

The LUZO INTEGRATED LED downlight is a combination of high-quality housing and most efficient LED technology from Philips. With a minimal power consumption despite its high luminous flux and its brilliant LED light colours of 2700K, 3000K or 4000K, LUZO INTEGRATED LED is ideal to exchange high-intense halogen or incandescent lamps. The LED module is interchangeable. This luminaire contains built-in LED lamps. EEK: A - A++. The lamps cannot be changed in the luminaire.