

NEW TRIA 1 recessed fitting

single-headed, QPAR111, square, matt black, max. 75W, incl. leaf springs

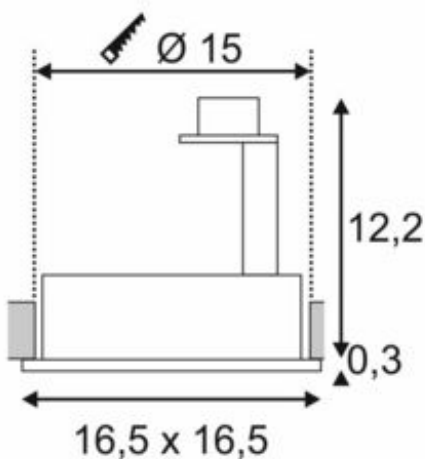
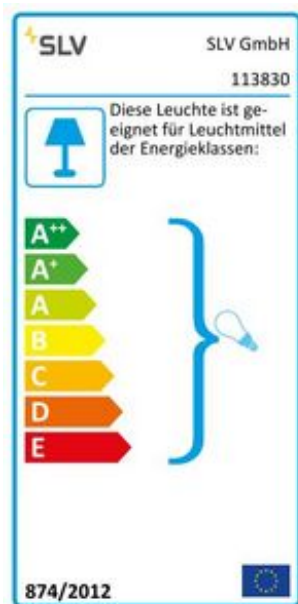

Article number	113830
Installation length	16.5 cm
Installation width	16.5 cm
Light distribution type 1	Direct
Feed-in capability	No
LBS code	QPAR111
Lamp	QPAR111
Lampholder / Socket	GU10
Number of light sources	1
Lamp included	No
Installation diameter	15 cm
Installation depth	12.5 cm
Tilt range	30 Degree
Rotation range	360 Degree
Length	16.5 cm
Width	16.5 cm
Height	12.5 cm
Net weight	0.431 kg
Gross weight	0.527 kg
Voltage	230 ~50 Volts
Max. wattage	75 Watt
Protection class	I
Material	Aluminium
Colour	matt black
Way of mounting	Recessed ceiling mounting
Energy efficiency class	A++
fastCalcEnabled	No
ranking	200
Catalogue page	BIG WHITE 2017: 429

The square ES111 high-voltage version of our popular NEW TRIA recessed fitting series is available with matt black, matt white or brushed aluminium housings. The generous rotation and pivoting range of this recessed spot guarantees you the ability to individually focus its light beam, regardless of whether you choose to use halogen or LED retrofit lamps. The NEW TRIA 1 recessed fitting is supplied ready for direct connection to the 230V alternating current.