

TRITON 6 downlight

round, silver anodized, 6x3W LED warmwhite, adjustable

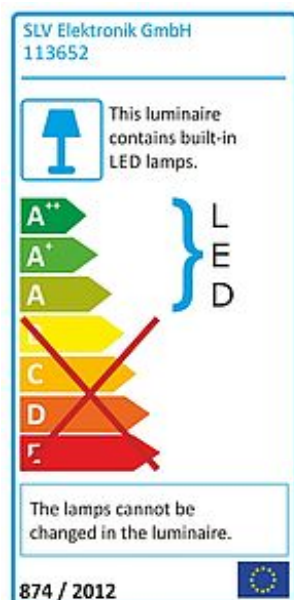

Article number	113652
Catalogue	BIG WHITE 2015, Page 398
Type of lamp	LED lamp
Lamp	Power LED 3W
Number of light sources	6
Lamp included	Yes
Installation diameter	10.8 cm
Installation depth	13.5 cm
Tilt range	60 Degree
Rotation range	20 Degree
Height	12 cm
Diameter	12 cm
Net weight	0.627 kg
Gross weight	0.751 kg
Max. wattage	18 Watt
Protection class	III
Beam angle	25 Degree
Material	aluminium
Colour	Silver
Way of mounting	recessed ceiling mounting
Remark 1	30 cm connection lead included
Remark 2	Operate with suitable 700 mA drivers only
Remark 3	Only suitable for ceilings with a maximum thickness of 20 mm
Remark 4	Energy labels in your language are available in the Service Area sub point Download
Average lifespan	30000 Hours
Colour temperature	3000 Kelvin
Colour rendering index	80
Luminous flux	900 lm
Suitable for lamps from EEC	A

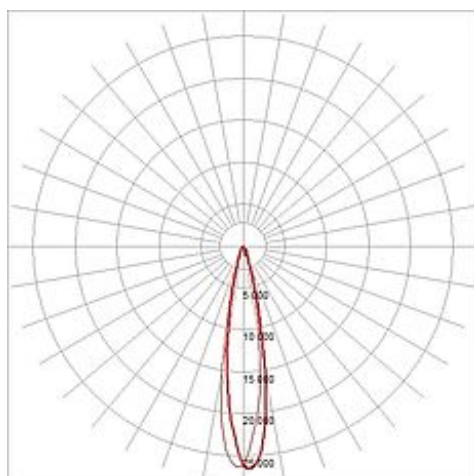
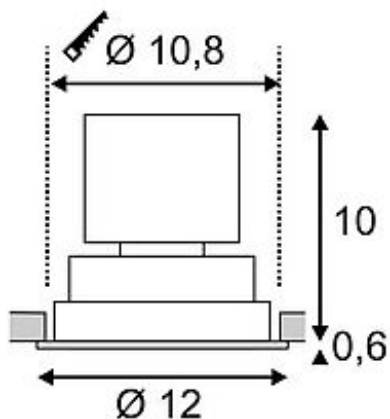

Suitable for lamps up to EEC	A++
Light distribution type 1	direct
Light distribution type 3	rotationally symmetric

The TRITON 6 LED downlight is adjustable and equipped with six Power LED of 3W each, optionally available in pure or warmwhite light colour. Available in matt white and anodized silver colour finish, TRITON 6 can be used as recessed wall or ceiling lamp. In addition, it contains a mini-plug for simplified connection via an optionally available connector strip. A suitable constant current driver providing 700mA is required for operation. This luminaire contains built-in LED lamps. EEK: A - A++. The lamps cannot be changed in the luminaire.