

TRITON 6 GIMBLE downlight

round, silver anodized, 6x 1W LED neutral white, adjustable

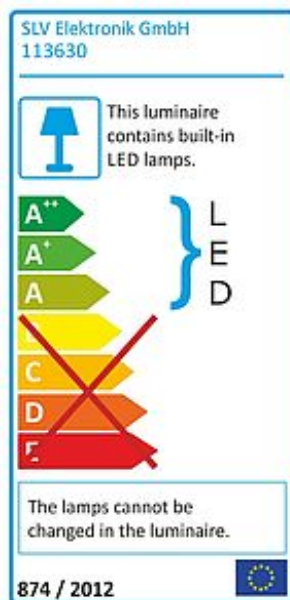

Article number	113630
Catalogue	BIG WHITE 2015, Page 398
Type of lamp	LED lamp
Lamp	Power LED 1W
Number of light sources	6
Lamp included	Yes
Installation diameter	10.8 cm
Installation depth	7.2 cm
Tilt range	45 Degree
Rotation range	350 Degree
Height	6 cm
Diameter	12 cm
Net weight	0.305 kg
Gross weight	0.382 kg
Max. wattage	6 Watt
Protection class	III
Beam angle	25 Degree
Material	aluminium
Colour	Silver
Way of mounting	recessed ceiling mounting
Remark 1	30 cm connection lead included
Remark 2	Only suitable for ceilings with a maximum thickness of 20 mm
Remark 3	Energy labels in your language are available in the Service Area sub point Download
Average lifespan	30000 Hours
Colour temperature	4000 Kelvin
Colour rendering index	80
Luminous flux	395 lm
Suitable for lamps from EEC	A
Suitable for lamps up to EEC	A++

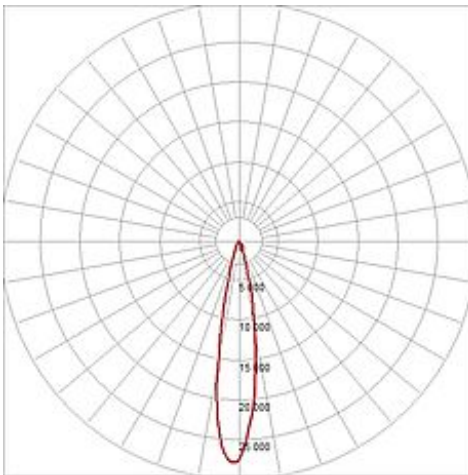
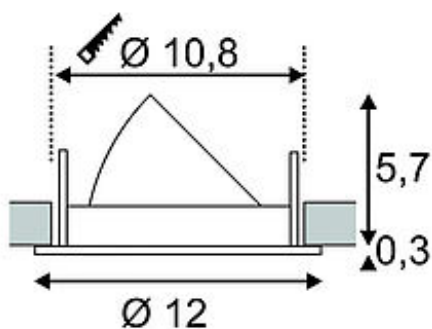

Light distribution
type 1

direct

Light distribution
type 3

rotationally symmetric

The TRITON GIMBLE LED downlight is made from aluminium and is available in matt white or anodized silver colour finish. The LED insert is telescopic and adjustable by 45°. It contains six incorporated Power LED with 1W each, optionally available in pure or warm white light colour. To operate the downlights a suitable constant current driver providing 350mA is required. This luminaire contains built-in LED lamps. EEK: A - A+++. The lamps cannot be changed in the luminaire.