

## NEW TRIA I QRB 111 downlight

square, matt white, max. 75W

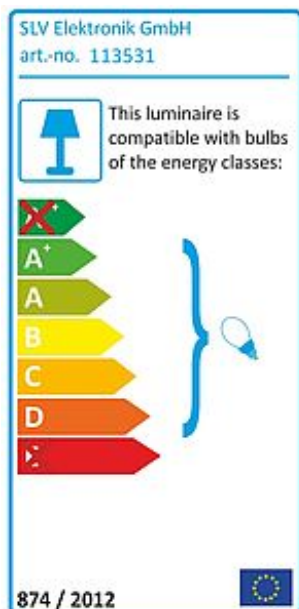

Article number	113531
Catalogue	BIG WHITE 2015, Page 456
Type of lamp	Conventional lamp
Lamp	QRB 111 12V max. 75W
Lampholder / Socket	G53
Number of light sources	1
Lamp included	No
Installation diameter	15 cm
Installation depth	12.5 cm
Tilt range	30 Degree
Rotation range	360 Degree
Length	16.5 cm
Width	16.5 cm
Height	12.5 cm
Net weight	0.393 kg
Gross weight	0.61 kg
Voltage	12 Volt
Max. wattage	75 Watt
Protection class	III
Material	aluminium
Colour	white
Way of mounting	recessed ceiling mounting
Remark 1	A suitable 12V transformer is required for operation
Remark 2	Energy labels in your language are available in the Service Area sub point Download
Suitable for lamps from EEC	D
Suitable for lamps up to EEC	A+
Light distribution type 1	direct
Light distribution type 3	rotationally symmetric

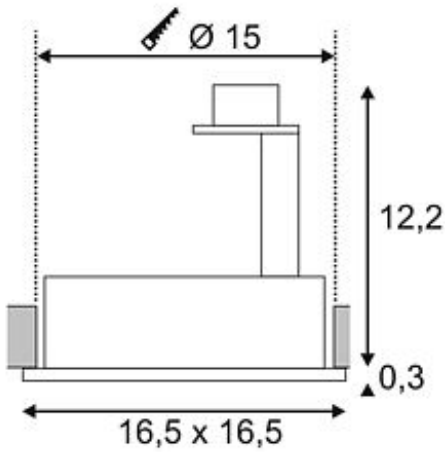

The square low-voltage QRB version of our NEW TRIA downlight series is available in either matt white or brushed aluminum colour version. The generously chosen rotation and tilt range guarantees the individual orientation of light, whether you choose standard halogen or LED retrofit lamps. To operate the NEW TRIA downlight a suitable low-voltage transformer providing 12V alternating current is required. This luminaire is compatible with bulbs of the energy classes: D - A+