

NEW TRIA MR16 ROUND Downlight

matt black, max. 50W, incl. retaining springs

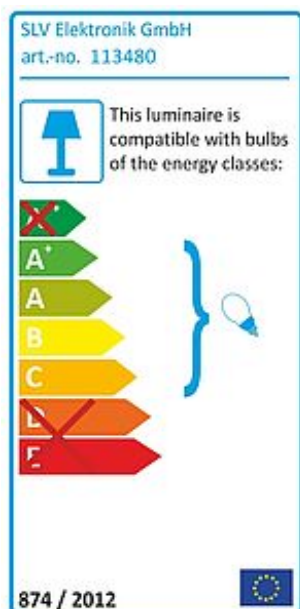

Article number	113480
Catalogue	BIG WHITE 2015, Page 405
Type of lamp	Conventional lamp
Lamp	MR16 12V max. 50W
Lampholder / Socket	GX5,3
Number of light sources	1
Lamp included	No
Installation diameter	7.8 cm
Installation depth	10.5 cm
Tilt range	30 Degree
Rotation range	360 Degree
Height	11 cm
Diameter	9.3 cm
Net weight	0.145 kg
Gross weight	0.184 kg
Voltage	12 Volt
Max. wattage	50 Watt
Protection class	III
Material	aluminium
Colour	black
Way of mounting	recessed ceiling mounting
Remark 1	Not suitable for the use of cool-beam lamps
Remark 2	A suitable 12V transformer is required for operation
Remark 3	Energy labels in your language are available in the Service Area sub point Download
Suitable for lamps from EEC	C
Suitable for lamps up to EEC	A+
Light distribution type 1	direct
Light distribution type 3	rotationally symmetric

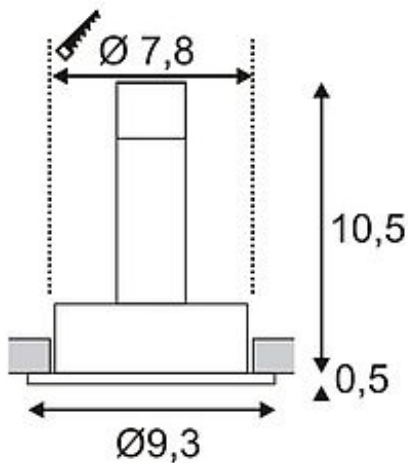

The round low-voltage version of our NEW TRIA downlight series is available in either matt white, matt black or brushed aluminum colour version. The generously chosen rotation and tilt range of the spot guarantees the individual orientation of light, whether your light source of interest is halogen or LED retrofit. To operate the NEW TRIA downlights you only need a matching transformer providing 12V alternating current. This luminaire is compatible with bulbs of the energy classes: C - A+