

HORN-A

recessed fitting, QPAR51, round, matt black, max. 50W, incl. clip springs

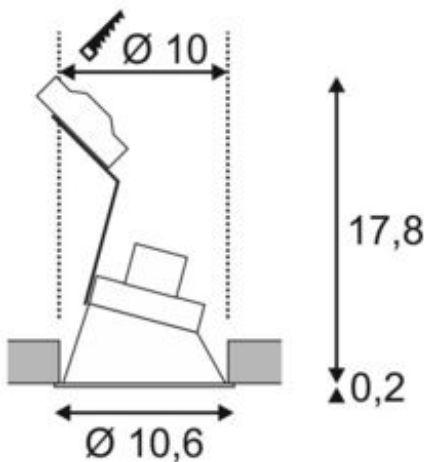

Article number	113150
Light distribution type 1	Direct
Feed-in capability	No
LBS code	QPAR51
Lamp	QPAR51
Lampholder / Socket	GU10
Number of light sources	1
Lamp included	No
Installation diameter	10 cm
Installation depth	18 cm
Height	18 cm
Diameter	10.6 cm
Net weight	0.259 kg
Gross weight	0.318 kg
Voltage	230 ~50 Volts
Max. wattage	50 Watt
Protection class	II
IP-rating	IP 21
Material	steel
Colour	matt black
Way of mounting	Recessed ceiling mounting
Energy efficiency class	A++
fastCalcEnabled	No
ranking	200
Catalogue page	BIG WHITE 2017: 471

Fixed high-voltage recessed fitting from the HORN series. The lamp is installed set to the rear in this luminaire which is made out of steel. This design creates a special appearance while effectively reducing glare. Multi-lamp and low-voltage versions of this series are available.