

NEW TRIA III ES111 downlight

rectangular, alu-brushed, GU10 , max. 3x 75W

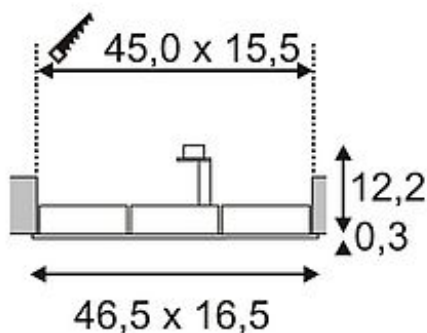
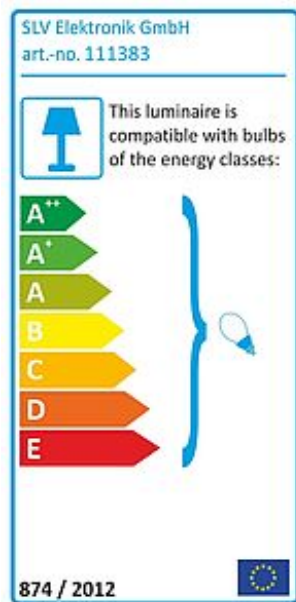

Article number	111383
Catalogue	BIG WHITE 2015, Page 457
Type of lamp	Conventional lamp
Lamp	ES111 230V max. 75W
Lampholder / Socket	GU10
Number of light sources	3
Lamp included	No
Installation length	45 cm
Installation width	15.5 cm
Installation depth	12.5 cm
Tilt range	30 Degree
Rotation range	360 Degree
Length	46.5 cm
Width	16.5 cm
Net weight	1.044 kg
Gross weight	0.481 kg
Voltage	230 Volt
Max. wattage	225 Watt
Protection class	I
Material	aluminium
Colour	aluminium brushed
Way of mounting	recessed ceiling mounting
Remark 1	Energy labels in your language are available in the Service Area sub point Download
Suitable for lamps from EEC	E
Suitable for lamps up to EEC	A++
Light distribution type 1	direct
Light distribution type 3	rotationally symmetric

The square ES111 version of our NEW TRIA downlight series is available in brushed aluminum colour version allows to be equipped with three illuminants. The generously chosen rotation and tilt range of the spot guarantees the individual orientation of light, whether your light source of interest is halogen or LED retrofit. NEW TRIA is ready for direct connection to 230V mains supply. This luminaire is compatible with bulbs of the energy classes: E - A++