

FLANGIA REEF / REEF ROOT S.5203 PALETTO MUSICALE / MUSICAL BOLLARD

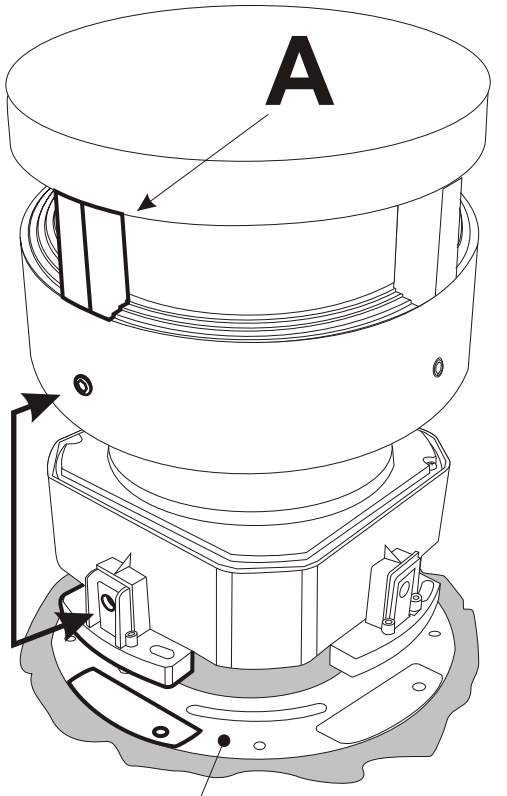

ISTRACCREEF REV 0 05/06

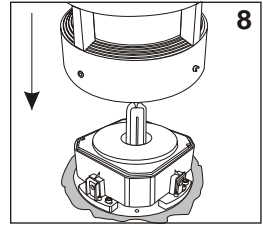
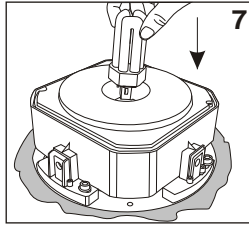
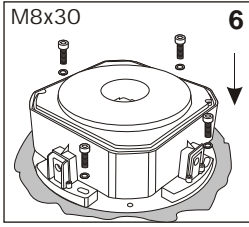
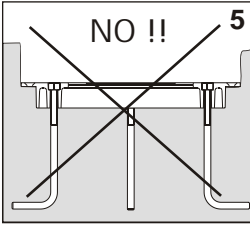
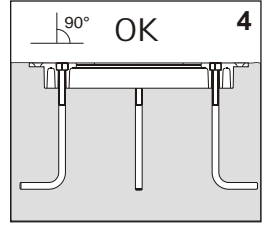
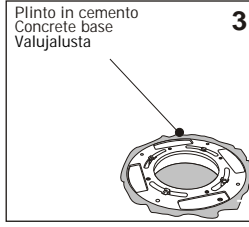
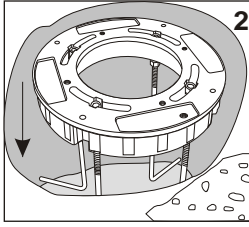
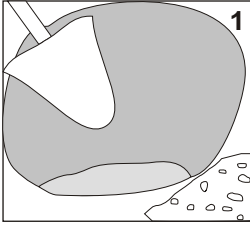

FLANGIA
ROOT

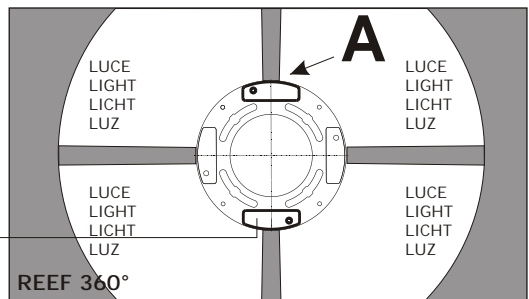
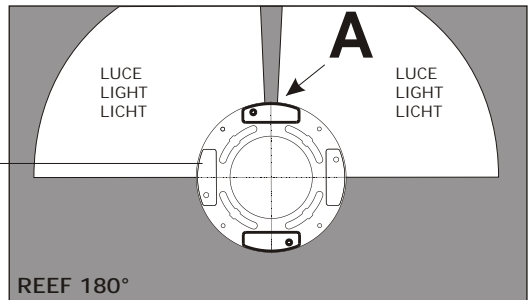
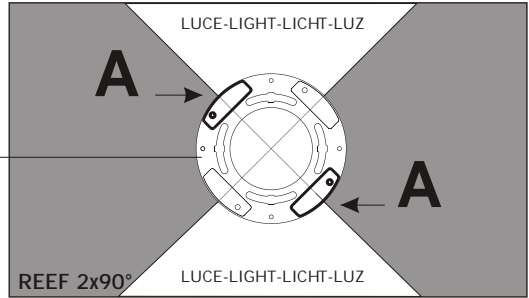

POSIZIONE DELLA FLANGIA A TERRA / ROOT POSITION IN THE GROUND
PER APPLICAZIONE DIRETTA DEL PRODOTTO O VERSIONE MUSICALE /
FOR DIRECT APPLICATION OR MUSICAL BOLLARD VERSION

PALETTO REEF REEF BOLLARD



ISTRACREEF REV 0 05/06

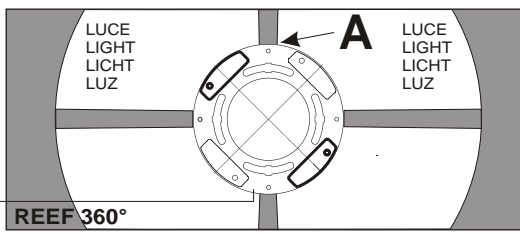
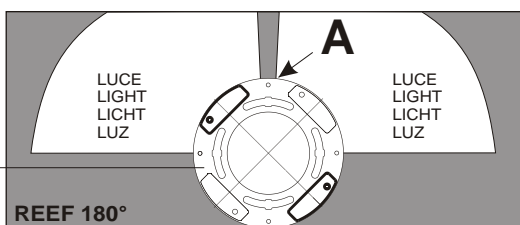
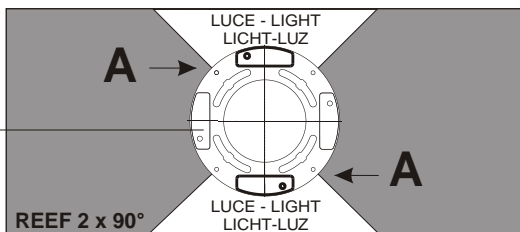
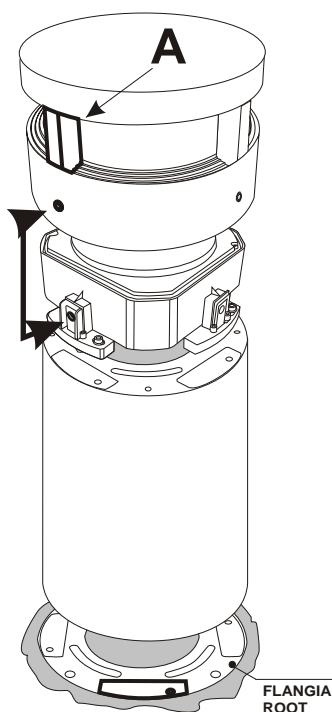
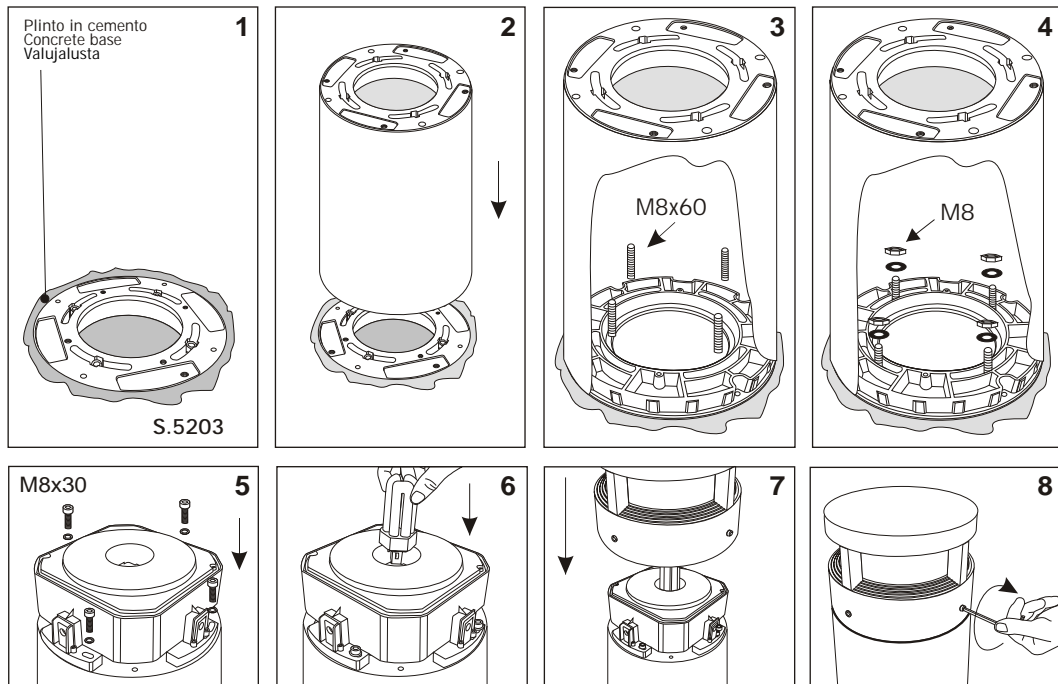

POSIZIONE DELLA FLANGIA A TERRA / ROOT POSITION IN THE GROUND
PER APPLICAZIONE CON PALETTO / FOR BOLLARD APPLICATION

SE Säkerheten hos armaturen garanteras bara om man följer europaiska elektiska normer samt bifogad monteringsanvisning. Markarmaturer är ständigt utsatta för vatten och fukt, därför måste instruktionerna följas noggrant för armatur och anslutningskabel. Installationsarbetet får endast utföras av behörig person. Använd ej högre effekt än angivet. Koppla ur armaturen innan den underhålls. Armatur måste vara jordat/sluten.

NL ALLE NIET VOORAF TOEGESTANE WIJZIGINGEN AAN DIT TOESTEL ZIJN VERBODEN !!

Het is dan ook noodzakelijk de montage-instructies strikt te volgen, dit vooreen langdurige en probleemloze werking van de installatie! De plaatsing van de toestellen dient uiteraard te gebeuren door gekwalificeerd personeel! Indien Sim es, bij eventuele problemen, de toestemming geeft om een toestel terug te sturen, dan dient het toestel enkel losgemaakt te worden van de inbouwdoos en de kabel op 20-30 cm te worden doorgesneden, zodat er bij de demontage niet wordt geraakt aan de aansluitdoos noch aan de wurgnippel.

P QUALQUER ALTERAÇÃO NESTE APARELHO, SEM AUTORIZAÇÃO, É INTERDITA !!

A seguirançada luminária é garantida somente quanto às normas elétricas europeias e a instrução encontra-se na embalagem. É necessário conservá-las após a montagem. Não utilize lâmpadas com potência superior ao limite indicado. Cortar a alimentação antes de executar a manutenção. A luminária deve ser ligada à terra. Utilizar cabos de alimentação do tipo HAR H07RN-F. No caso da SAMES dar o seu acordo para o envio da luminária para controle esta não deverá ser desmontada (abrir unicamente o anel superior para a separação do negativo de encastramento se necessário). A caixa de ligação NÃO DEVE SER ABERTA, o bico não deve ser mexido. É necessário deixar à saída da caixa de ligações um bico de conexão de 10 a 20 cm.

CLASSE II
CLASS II
SCHUTZKLASSE II
SUOJAUSSLUOKKA II

KLASS II
KLASSE II
класс II
CLASE II

ART.	Lampada Lamp Lampe	Ljuskälla Lámpara Lampputyyppi	Светильника Lâmpada
S.5206	HIT-CRI	35W	G 12
S.5208	HIT-CRI	70W	G 12
S.5209	TC-T	26W	Gx24d-3
S.5216	HIT-CRI	35W	G 12
S.5218	HIT-CRI	70W	G 12
S.5219	TC-T	26W	Gx24d-3
S.5226	HIT-CRI	35W	G 12
S.5228	HIT-CRI	70W	G 12
S.5229	TC-T	26W	Gx24d-3
S.5236	HIT-CRI	35W	G 12
S.5238	HIT-CRI	70W	G 12
S.5239	TC-T	26W	Gx24d-3
S.5273	HIT-CRI	35W	G 12
S.5274	HIT-CRI	70W	G 12
S.5275	TC-T	26W	Gx24d-3

Per lampade HIT-TC CRI utilizzare solo lampade UV-STOP
For METAL HALIDE versions use only UV-STOP lamps
Für Leuchtmittel HIT-TC CRI benutzen nur UV-STOP Lampe
Pour lampes HIT-TC CRI utiliser seulement ampoule UV-STOP
Para la versión HIT-TC CRI utilizar solamente lámparas UV-STOP

Vid användning av METAL HALOGEN, använd bara UV-STOP ljuskällor
Gebruik voor alle Metal Halogene armaturen uitsluitend UV-STOP lampen
Käytä monimetallivalaisimissa vain UV-STOP -lamppuja
Utilizar somente lâmpadas UV-STOP nas versões HIT-TC CRI

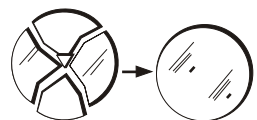

I Sostituire lo schermo in caso di danneggiamento prima di riutilizzare l'apparecchio.
GB In case of diffuser damage change it before to switch on the fitting.
D Beschädigte Abdeckungen vor erneuter Inbetriebnahme austauschen.
F En cas de dommages, remplacer le diffuseur avant réutilisation de l'appareil.
E En caso de difusor dañado cambiarlo antes de encender el aparato.
SE Vid byte av trasigt glas, kopplas armaturen ur.
NL Bij glasbreuk dient het glas vervangen te worden vooraleer het armatuur aan te schakelen.
RU в случае повреждения рассеивателя, не включайте светильник до его замены.
FI Vioittunut suojalasi on vaihdettava uuteen ennen valaisimen käyttöä.
P Em caso de avaria do difusor, substituir por outro antes da reutilização da luminária.

- Usare solo ricambi originali SIMES.
- Use only SIMES original spare parts.

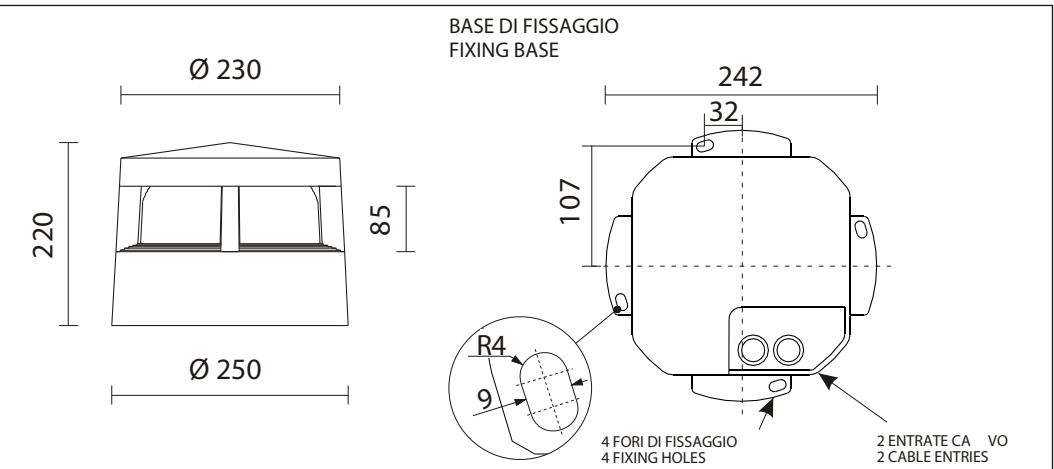

ISTRUZIONI GENERALI DI INSTALLAZIONE
GENERAL MOUNTING INSTRUCTIONS



ISTRUZIONI GENERALI DI INSTALLAZIONE
GENERAL MOUNTING INSTRUCTIONS

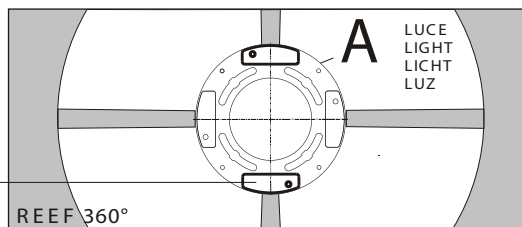
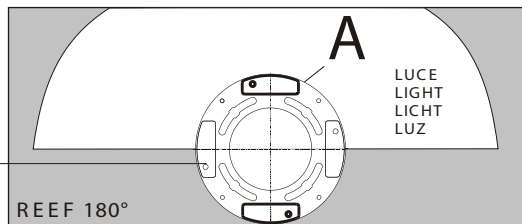
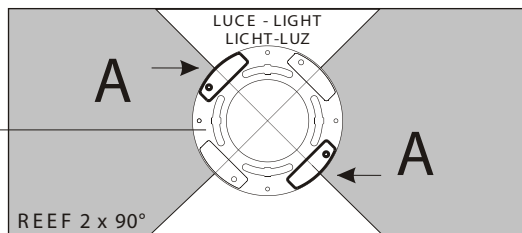
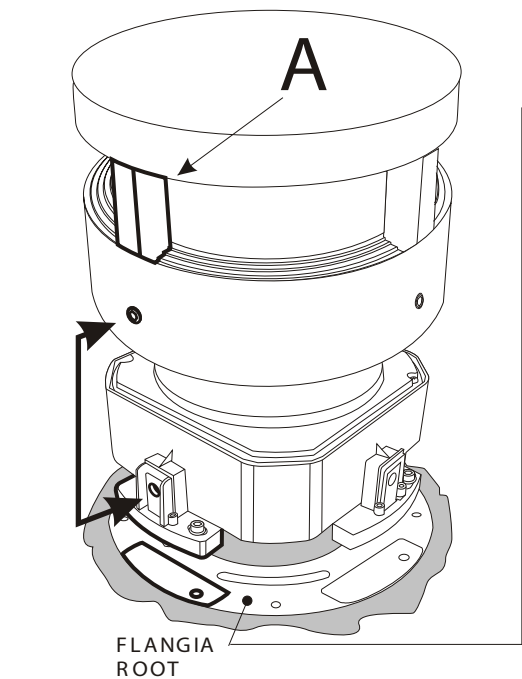
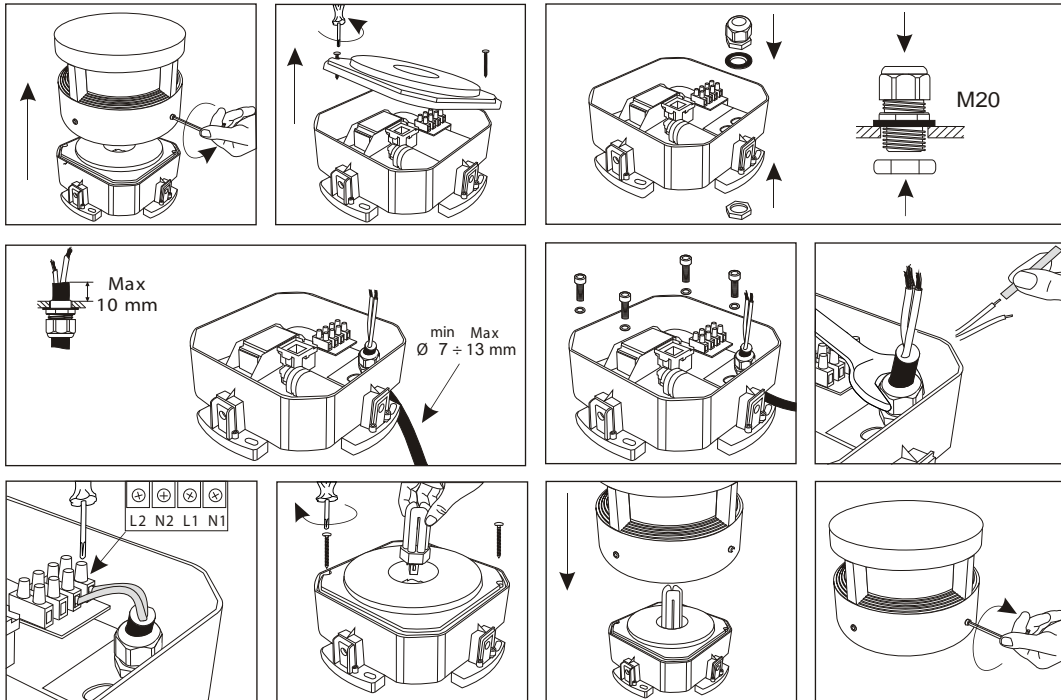

I OGNI MODIFICA DELL'APPARECCHIO E' PROIBITA SENZA PREVIA AUTORIZZAZIONE !!

La sicurezza dell'apparecchio è garantita solo rispettando le normative europee del settore elettrico e le istruzioni contenute in questa scatola; pertanto è necessario conservarle.
Non utilizzare lampade di potenza superiore al limite indicato.
Togliere tensione prima di eseguire le operazioni di manutenzione.
Utilizzare cavi di alimentazione tipo <HAR>.
Per applicazioni a parete tenere l'entrata cavi in basso.
Nel caso in cui SAMES S.p.A. dia il consenso al reso di apparecchi per il controllo, essi dovranno essere resi senza essere smontati.
La scatola di cablaggio NON DEVE essere aperta; il pressacavo non deve essere toccato; deve essere lasciato un pezzo di cavo di alimentazione di 10-20 cm. uscente dalla scatola di cablaggio.

GB ANY MODIFICATION TO THIS FITTING IS FORBIDDEN WITHOUT AUTHORIZATION !!

The safety of the fitting is guaranteed only respecting the electrical European norms and the mounting instructions in this box; therefore it is important to conserve them.
Do not use lamps with higher power than indicated.
Disconnect main voltage before maintenance operations.
Use only <HAR> cables.
For wall application leave the cable entry to the bottom.
If SAMES S.p.A. agrees to receive back some fittings for laboratory testing, they MUST NOT BE DISASSEMBLED.
The connection box, where the wiring to the terminal block is done, must not be opened and you must cut the cable around 10-20 cm from the connection box.

D JEDE UNBEFUGTE ÄNDERUNG AN DIESER LEUCHE IST VERBOTEN !!

Die Sicherheit der Leuchte ist nur bei Einhaltung der europäischen Normen und der in dieser Packung enthalten en Montageanleitungen gewährleistet. Diese sind daher sorgfältig aufzubewahren.
Wenn SAMES S.p.A. der Rücksendung von Leuchten zwecks Prüfung zustimmt, diese bitte vorher nicht zerlegen.
Nicht den Anschlusskasten und die Verschraubung öffnen, das Kabel in 10-20 cm.
Abstand von der Anschlussdose durchtrennen. Keine Lampen höherer Leistung als angegeben verwenden.
Vor Wartungsarbeiten die Leuchte vom Netz trennen.
Die Leuchte muss an die Erdung der Anlage angeschlossen sein.

F TOUTE MODIFICATION DE CET APPAREIL, SANS AUTORISATION, EST INTERDITE !!

La sécurité des appareils est garantie uniquement en respectant les normes électriques européennes et les instructions contenues dans l'emballage; aussi est-il nécessaire de les conserver.
Dans le cas où SAMES S.p.a donne son accord pour un retour d'appareils afin d'en effectuer le contrôle, ceux-ci devront être rendus sans être démontés. La boîte de câblage ne DOIT PAS être ouverte, le presse-étoupe ne doit pas être touché; il faut laisser, à la sortie de la boîte de câblage, un morceau de câble d'alimentation de 10 à 20 cm.
Ne pas utiliser des puissances de lampes supérieures à la limite indiquée.
Couper l'alimentation avant d'exécuter toute manutention.
L'appareil doit être relié à la terre.

E CUALQUIER MODIFICACION DE LOS APARATOS ESTA PROHIBIDA SIN AUTORIZACION !!

La seguridad de los aparatos está garantizada solamente respetando las normas eléctricas Europeas y las instrucciones de montaje incluidas en la caja, es importante conservarlas.
En el caso que SAMES S.p.A. deba analizar algún aparato, deberá entregarse sólo el aro superior.
La caja de cableado NO DEBE ABRIRSE; el prensa no debe tocarse y debe dejarse un cable de 10-20 cm saliendo de la caja de cableado.
No usar lámparas de potencia superior a la indicada.
Desconectar voltaje principal antes de continuar las operaciones de mantenimiento.
Los aparatos deben conectarse al circuito de tierra principal.