

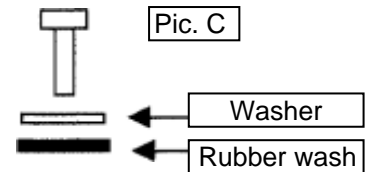

# MINIEOS RECTANGULAR

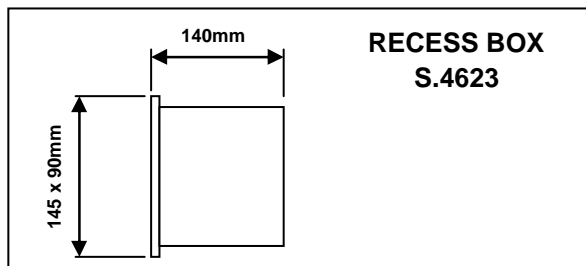
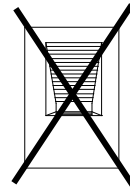
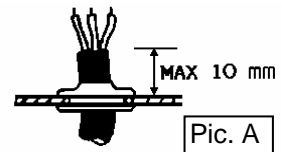
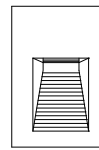
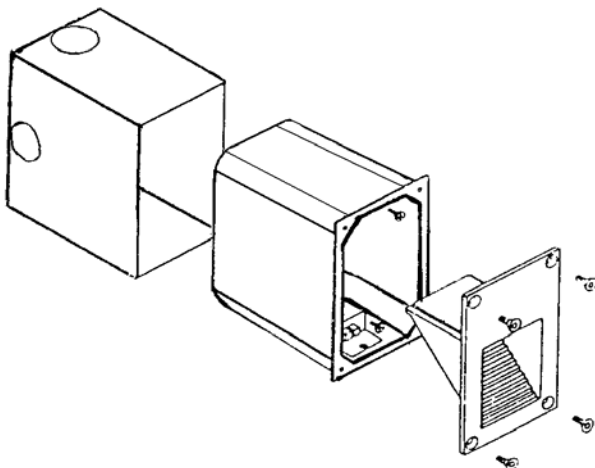
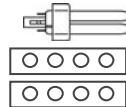

## MINIEOS RECTANGULAR

for compact fluorescent lamp 10W G24d-1 FSQ  
4 accent LED 6000K 6W 230-240V  
4 accent LED 3200K 6W 230-240V



ART.S.4629   
ART.S.4621  
ART.S.4621W

## TECHNICAL CHARACTERISTICS:

PROTECTION LEVEL : IP65  
CLASS I

## ASSEMBLING INSTRUCTIONS:

Open the fitting and remove the reflector  
After drilling the grommets fit to the base and introduce the double sheath cable (**Pic. A**) and cover the wires with supplied slaves (**Pic. B**)  
Connect them to terminal block.  
Fix the fitting to pre-installed recess box with the supplied screws assembled under the screw head with the metal and rubber washer (**Pic. C**)  
Re-install the reflector  
Insert the correct lamp - **USE ONLY OSRAM LAMPS MADE IN EUROPE FOR THE FITTING ART. S.4629**  
Close the fitting

## RECOMMENDATIONS:

Do not exceed the maximum allowed wattage  
Disconnect the supply before effecting the maintenance  
The fitting must be earthed  
Entry with cable for max 10 mm (**Pic. A**)  
Use <HAR> type feed cables with Diameter 6 ÷ 10 mm  
For installation use accessory recess-box ART. S.4623

Installation should be carried out by a suitably qualified person in accordance with good electrical practice and the appropriate national wiring regulations

It is very important to follow these instruction to enable the fitting to be installed correctly. Please retain for information.

**SIMES**  
luci per l'architettura  
ISTR4629 REV.7 09/12

# MINIEOS RETTANGOLARE

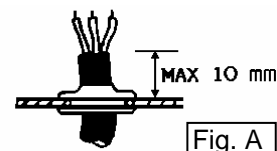
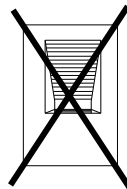
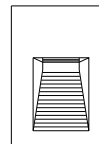
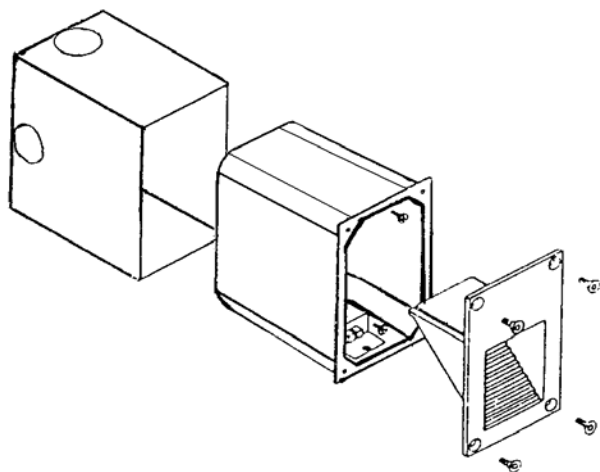
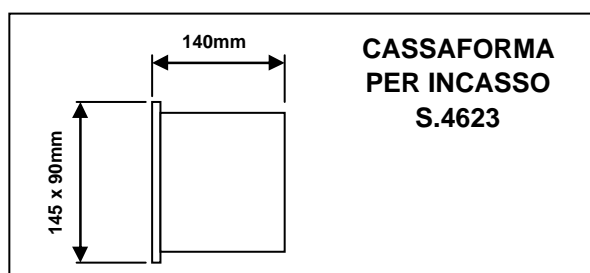

Fig. A



Fig. B



**CASSAFORMA  
PER INCASSO  
S.4623**

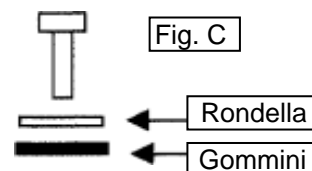
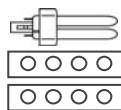



Fig. C

## MINIEOS RETTANGOLARE

for compact fluorescent lamp 10W G24d-1 FSQ  
4 accent LED 6000K 6W 230-240V  
4 accent LED 3200K 6W 230-240V



ART.S.4629   
ART.S.4621  
ART.S.4621W

## CARATTERISTICHE TECNICHE

IP65  
CLASSE I

## ISTRUZIONI DI MONTAGGIO

Aprire l'apparecchio e rimuovere il riflettore  
Introdurre il gommino passacavo dopo averlo forato nel foro della base, quindi il cavo con la doppia guaina (**Fig. A**) e ricoprire i fili con le guaine in dotazione (**Fig. B**)  
Effettuare il cablaggio elettrico  
Fissare l'apparecchio alla cassaforma pre-installata con le viti in dotazione montando le rondelle ed i gommini sottotesta (**Fig. C**)  
Reinstallare la parabola  
Inserire la lampada adatta - **USARE SOLO LAMPADE OSRAM PRODOTTE IN EUROPA PER ARTICOLO S.4629**  
Chiudere l'apparecchio

### NOTE

Non superare la potenza indicata nei dati di targa  
Togliere tensione prima di effettuare manutenzioni  
La presa di terra è obbligatoria  
Utilizzare cavi di alimentazione a norme <HAR> con diametri 6 ÷ 10 mm  
Per l'installazione usare l'apposita cassaforma ART.S.4623

L'installazione deve essere eseguita da personale qualificato secondo le norme di settore

Il rispetto di queste norme è molto importante per l'efficienza dell'apparecchio e per la sicurezza delle persone, pertanto esse vanno conservate

**SIMES**  
lucci per l'architettura

ISTR4629 REV.7 09/12