

TECHNICAL DATA SHEET ART. S.6160 - MOAI

Available until 31/12/2017 but subject to stock levels

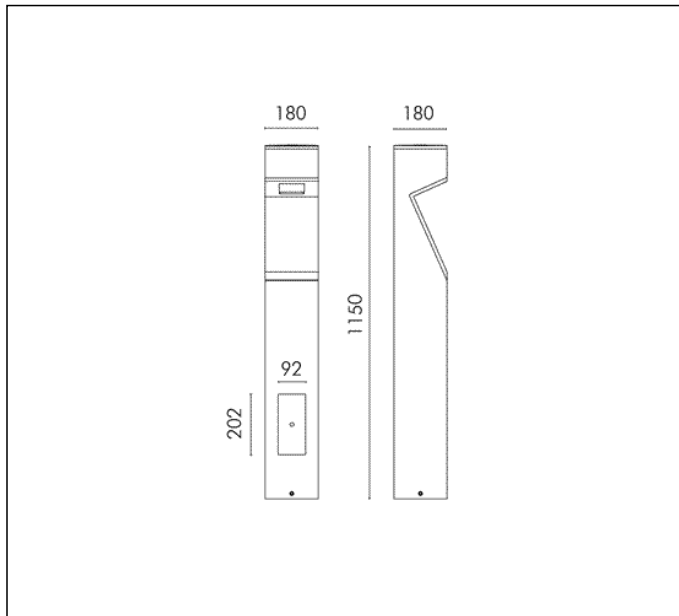

MODULES LED 6000K 230V CRI 75
 Rated luminaire luminous flux: 677lm
 Rated input power: 34.4W
 Luminaire efficacy: 20lm/W
 Electronic ballast 220÷240V 0/50/60Hz

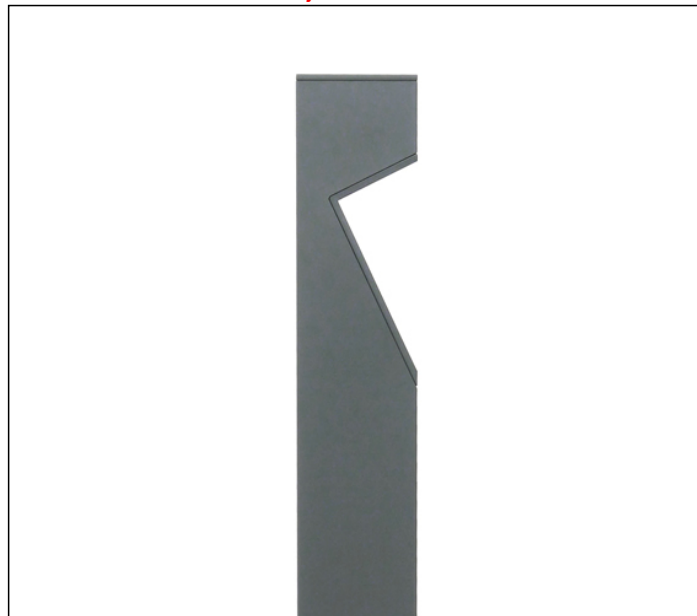
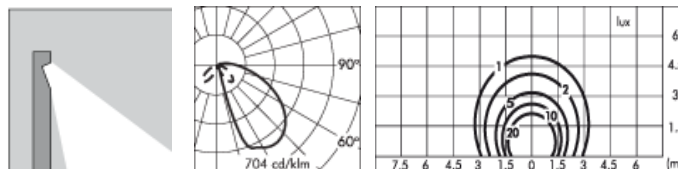

Fixture available with integral DALI driver on request with surcharge.

PRODUCT TYPE

Bollard fitting. IP rating IP 65

MATERIAL CHARACTERISTICS

Extruded EN AW-6060 aluminium profile, die-cast EN AB-47100 aluminium housing with high corrosion resistance. Stone wash surface treatment prior to painting process. A4 grade Stainless Steel screws with 2,5-3% molybdenum content which increases the resistance against corrosion. Pre treated Silicone Gaskets. Painting Process : 3 Step Process

1) Surface treatment with BONDERITE. A heavy metal free chemical surface treatment containing ceramic nano particles giving a cohesive, inorganic and highly dense protective coating. 2) PRE POLYMERIZATION a process of introducing an epoxy primer with excellent characteristics to the paint which also offers very high resistance to oxidation due to its Zinc content. 3) POLYMERIZATION a process with the application of polyester powder with high resistance against UV rays and harsh weather conditions. Resistance test protection for Marine applications for 1200h. Mechanical resistance IK 06

VERY SOLID BOLLARD

The accessory flange when rooted into the ground provides extra protection and prevents the bollard from being knocked over. The bollard head component is made from a one piece ALUMINIUM DIE-CAST. The 4 angled sides provide a very rigid solution.

LIGHTING PERFORMANCE

The optic system combines 2 elements: 1) reflector 99.98% pure aluminium; 2) enlongation lenses The reflector is placed above the lamp to maximize the light output, capturing any indirect light, reflecting the rays back down towards the prismatic lens. An ENLONGATION LENS provides even horizontal light distribution at ground level. The lens is fixed to the aluminium support with a very strong resin. The eye perception is even lighting when the luminaire is in a real environment. Lamp fixed position . LOR --

WIRING

Supply 1.5m cable section type H07RN-F . The installation is easy: the lamp body is installed on the bollard structure, and is then fixed to it through an allen screw placed on the back of the bollard. The absence of screws in sight enhances the essential, minimalistic design of the fitting. Supplied with IP67 fast connector. The connector must be connected at the supply line (Ø 12÷16 mm). Isolation: CLASS I . Available colours: Aluminium grey (cod.14). Weight: 11.9 Kg Glow Wire test: --

L.E.D circuit included.

MOAI REGISTERED DESIGN

This luminaire contains built-in LED modules with energy class: A, A+, A++. In case of damage or malfunction please contact the manufacturer to receive additional instructions on how to replace and relative spare parts to order. The LED modules cannot be handled in the luminaire by the end user (Regulation UE 874/2012).

LED circuit boards are engineered accordingly to actual Lumen Maintenance regulation (LM80) and Technical Memorandum (TM21) where uniformity and quality of light is 50.000 hours referred to L70 B20 Ta 25°C.

Lifecycle refers to LED circuit boards only, all others components of the luminaire are excluded.

EMERGENCY VERSIONS

The fittings operates both on AC (50/60Hz) and DC (0Hz) voltage.

TECHNICAL DATA SHEET ART. S.6160 - MOAI INCLUDED ACCESSOIRES



FAST CONNECTOR INCLUDED

ACCESSORIES



**S.5310
FLANGE**
Ø 180 mm flange to be fixed in concrete with stainless steel screws for fixing in the ground.

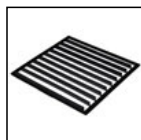

**S.6169
ANTIGLARE SHIELD**

Further information

FIXING BASE

