

TECHNICAL DATA SHEET ART. S.5851.19 - ZIP DOWNLIGHT ROUND

Available until 31/12/2017 but subject to stock levels

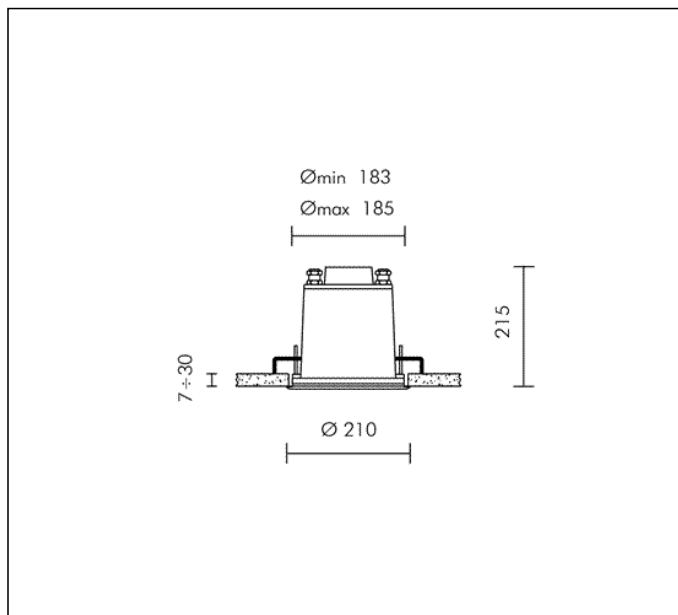

HIT-TC CRI 20W G8,5 1700lm
 Rated luminaire luminous flux: 918lm
 Rated input power: 22W
 Luminaire efficacy: 42lm/W (LOR: 54%)
 Electronic ballast 220÷240V 0/50/60Hz

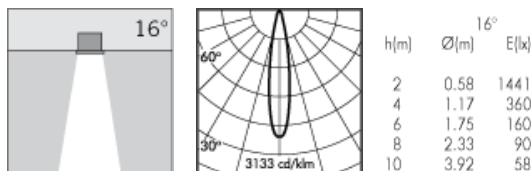

PRODUCT TYPE

False ceiling-recessed down-light fitting. Recessing depth 215 mm. IP rating IP 65

MATERIAL CHARACTERISTICS

"Copper Free" Aluminium die cast housing in EN AB-44100 with high resistance against corrosion. Stone wash surface treatment prior to painting process. 2 mm thick front trim in Stainless Steel - Grade AISI 316L with 2,5-3% molybdenum content. A4 grade Stainless Steel screws with 2,5-3% molybdenum content which increases the resistance against corrosion. Pre treated Silicone Gaskets. Painting Process : 3 Step Process

1) Surface treatment with BONDERITE. A heavy metal free chemical surface treatment containing ceramic nano particles giving a cohesive, inorganic and highly dense protective coating. 2) PRE POLYMERIZATION a process of introducing an epoxy primer with excellent characteristics to the paint which also offers very high resistance to oxidation due to its Zinc content. 3) POLYMERIZATION a process with the application of polyester powder with high resistance against UV rays and harsh weather conditions. Resistance test protection for Marine applications for 1200h. Mechanical resistance IK 09

LIGHTING PERFORMANCE

Reflector in 99.98% pure anodized aluminium (with TC and HIT lamp version). Toughened semiacid-etched glass 10mm thick. Lamp adjustable ±15° position. LOR 54%

INSTALLATION AND MAINTENANCE

The luminaires are fixed to the false ceiling by a heavy-duty bracket system, adjustable from inside the luminaire. Front re-lamping without removing the complete fitting from the ceiling.

WIRING

Double cable entry with cable glands PG 13.5 (Ø 6÷12 mm) . Isolation: CLASS I . Available colours: Stainless steel (cod.19). Weight: 2.6 Kg Glow Wire test: 850°C
Lamp included.

This luminaire is compatible with bulbs of the energy classes: A. The luminaire is sold with a bulb of the energy class: A (Regulation UE 874/2012).

EMERGENCY VERSIONS

The fittings operates both on AC (50/60Hz) and DC (0Hz) voltage.

TECHNICAL DATA SHEET ART. S.5851.19 - ZIP DOWNLIGHT ROUND ACCESSORIES



S.5520 CONCRETE CEILING INSTALLATION KIT

Kit :

- _ steel plate;
- _ round recessed box.

Dimensions: Ø 190 mm h 240 mm