

TECHNICAL DATA SHEET ART. S.5832.19 - MICROZIP LED DOWNLIGHT SQUARE

Available until 31/12/2017 but subject to stock levels

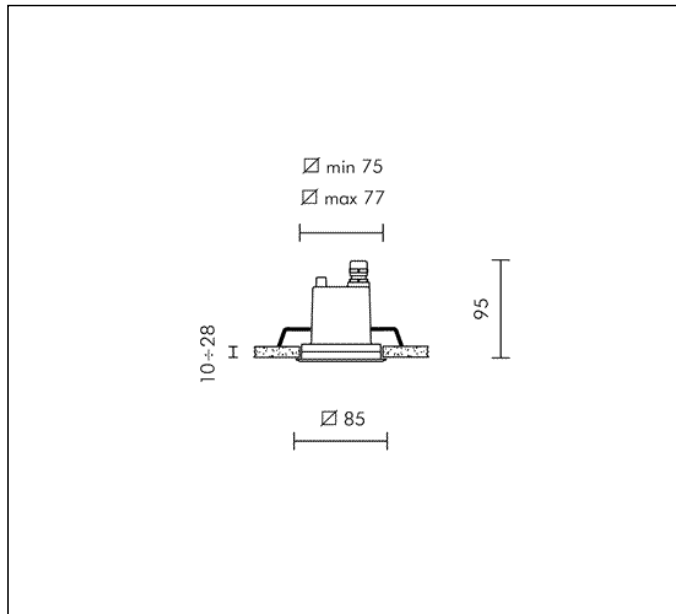

1 MODULES LED 6000K 230V 130lm 1W CRI 75

Rated luminaire luminous flux: 110lm

Rated input power: 2.2W

Luminaire efficacy: 50lm/W

Electronic ballast 220÷240V 0/50/60Hz

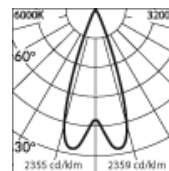
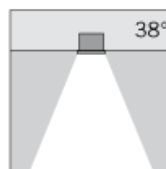

	38°	6000K	3200K
h(m)	Ø(m)	E(lx)	E(lx)
1	0.69	219	191
2	1.39	55	48
3	2.08	24	21
4	2.77	14	12
5	3.46	9	8



PRODUCT TYPE

False ceiling-recessed down-light fitting. Recessing depth 95 mm. IP rating IP 65

MATERIAL CHARACTERISTICS

"Copper Free" Aluminium die cast housing in EN AB-44100 with high resistance against corrosion. Stone wash surface treatment prior to painting process. 2 mm thick front trim in Stainless Steel - Grade AISI 316L with 2,5-3% molybdenum content. A4 grade Stainless Steel screws with 2,5-3% molybdenum content which increases the resistance against corrosion. Pre treated Silicone Gaskets. Painting Process : 3 Step Process

1) Surface treatment with BONDERITE. A heavy metal free chemical surface treatment containing ceramic nano particles giving a cohesive, inorganic and highly dense protective coating. 2) PRE POLYMERIZATION a process of introducing an epoxy primer with excellent characteristics to the paint which also offers very high resistance to oxidation due to its Zinc content. 3) POLYMERIZATION a process with the application of polyester powder with high resistance against UV rays and harsh weather conditions. Resistance test protection for Marine applications for 1200h. Mechanical resistance IK 09

LIGHTING PERFORMANCE

Toughened semiacid-etched glass 8mm thick. Lamp adjustable ±15° position. LOR --

INSTALLATION AND MAINTENANCE

The luminaires are fixed to the false ceiling by a heavy-duty bracket system, adjustable from inside the luminaire. Front re-lamping without removing the complete fitting from the ceiling.

WIRING

Luminaire hard wired with 1m H07RN-F cable. Isolation: CLASS I . Available colours: Stainless steel (cod.19). Weight: 0.6 Kg Glow Wire test: 850°C

Lamp included.

This luminaire contains built-in LED modules with energy class: A, A+, A++. In case of damage or malfunction please contact the manufacturer to receive additional instructions on how to replace and relative spare parts to order. The LED modules cannot be handled in the luminaire by the end user (Regulation UE 874/2012).

LED circuit boards are engineered accordingly to actual Lumen Maintenance regulation (LM80) and Technical Memorandum (TM21) where uniformity and quality of light is 50.000 hours referred to L70 B20 Ta 25°C.

Lifecycle refers to LED circuit boards only, all others components of the luminaire are excluded.

EMERGENCY VERSIONS

The fittings operates both on AC (50/60Hz) and DC (0Hz) voltage.

TECHNICAL DATA SHEET ART. S.5832.19 - MICROZIP LED DOWNLIGHT SQUARE ACCESSORIES



S.5509

SQUARE RECESSED BOX

For cement ceiling installation.

Dimensions: 80÷124 mm h 110 mm