

## TECHNICAL DATA SHEET ART. S.5495NSC.19 - MINILINEAR STAINLESS FRONT TRIM

Version is available on request

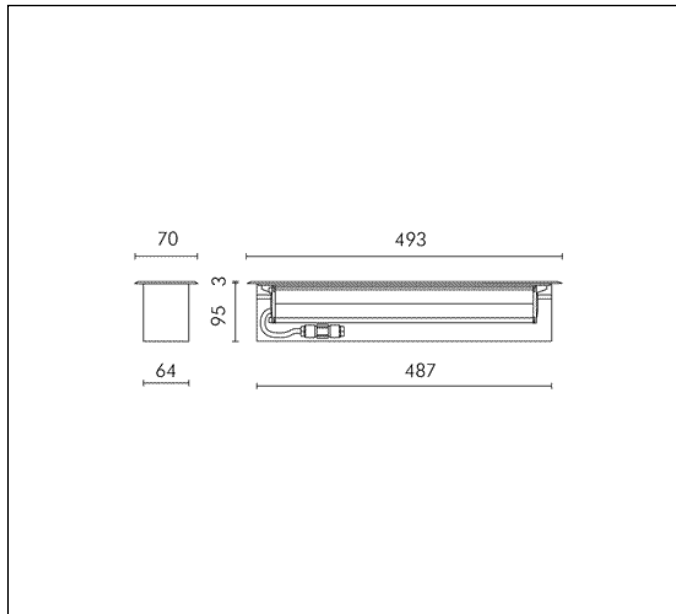
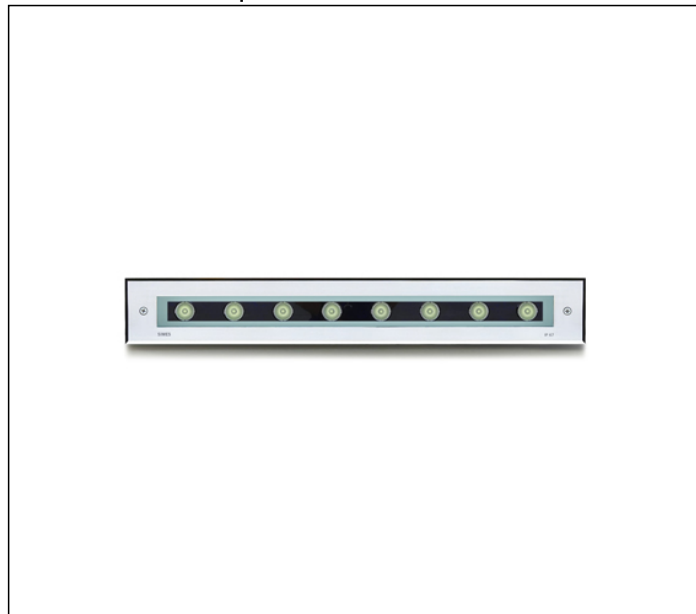

8 MODULES LED 4000K 230V 1440lm 12W CRI 90

Rated luminaire luminous flux: 867lm

Rated input power: 13.8W

Luminaire efficacy: 63lm/W

Electronic ballast 230÷240V 50Hz

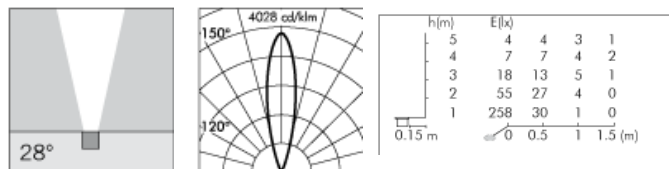

\* Photometric measured using WHITE LED 3000K



### PRODUCT TYPE

Inground walk over fitting. Recessing depth 95 mm. IP rating IP 67

### MATERIAL CHARACTERISTICS

"Copper Free" Aluminium die cast housing in EN AB-44100 with high resistance against corrosion. Stone wash surface treatment prior to painting process. 3 mm thick front trim in Stainless Steel - Grade AISI 316L with 2,5 -3% molybdenum content, with high resistance against corrosion. A4 grade Stainless Steel screws with 2,5-3% molybdenum content which increases the resistance against corrosion. Pre treated Silicone Gaskets. Painting Process : 3 Step Process

1) Surface treatment with BONDERITE. A heavy metal free chemical surface treatment containing ceramic nano particles giving a cohesive, inorganic and highly dense protective coating. 2) PRE POLYMERIZATION a process of introducing an epoxy primer with excellent characteristics to the paint which also offers very high resistance to oxidation due to its Zinc content. 3) POLYMERIZATION a process with the application of polyester powder with high resistance against UV rays and harsh weather conditions. Resistance test protection for Marine applications for 1200h. Mechanical resistance IK 09 Maximum load capacity 500 Kg

### LIGHTING PERFORMANCE

Reflector in 99.98% pure anodized aluminium (with linear fluorescent lamp version). semiacid-etched Toughened glass 6mm thick. Lamp fixed position. LOR -- Compact electronic ballast to guarantee better lamp stability, lifetime and reduced energy consumption.

### LOW SURFACE TEMPERATURE

Surface temperature of glass 40°C (Ta 25°C) Electronic Ballast generating less heat. Specific layout of internal components allow for better heat dissipation therefore limiting the temperature generated inside the fitting.

### RECESSING BOX

Recessing box in aluminium grade AISI 316L with cable entry on all 4 sides also allows: 1) Easy wiring; 2) Cable management for fast connector; 3) Easy access to the fitting for maintenance purposes.

### WIRING

Supply 0.5m cable section type H07RN-F and sealed with B component epoxy resin, wired internally protected by silicon sheaths. Fast connector M20 (Ø 5÷14 mm) supplied as standard for single cable connection . Connector housed inside the recessing box . Lateral re-lamping without removing the diffusor. Isolation: CLASS I .

Available colours: Stainless steel (cod.19). Weight: 3 Kg Glow Wire test: --

L.E.D circuit included.

This luminaire contains built-in LED modules with energy class: A, A+, A++. In case of damage or malfunction please contact the manufacturer to receive additional instructions on how to replace and relative spare parts to order. The LED modules cannot be handled in the luminaire by the end user (Regulation UE 874/2012).

LED circuit boards are engineered accordingly to actual Lumen Maintenance regulation (LM80) and Technical Memorandum (TM21) where uniformity and quality of light is 50.000 hours referred to L70 B20 Ta 25°C.

Lifecycle refers to LED circuit boards only, all others components of the luminaire are excluded.

**TECHNICAL DATA SHEET ART. S.5495NSC.19 - MINILINEAR STAINLESS FRONT TRIM  
INCLUDED ACCESSOIRES**



FAST CONNECTOR INCLUDED

**ACCESSORIES**



CAS5482



CAS5482