

## TECHNICAL DATA SHEET ART. S.5314N - MINICUBIKS LED

Version is available on request

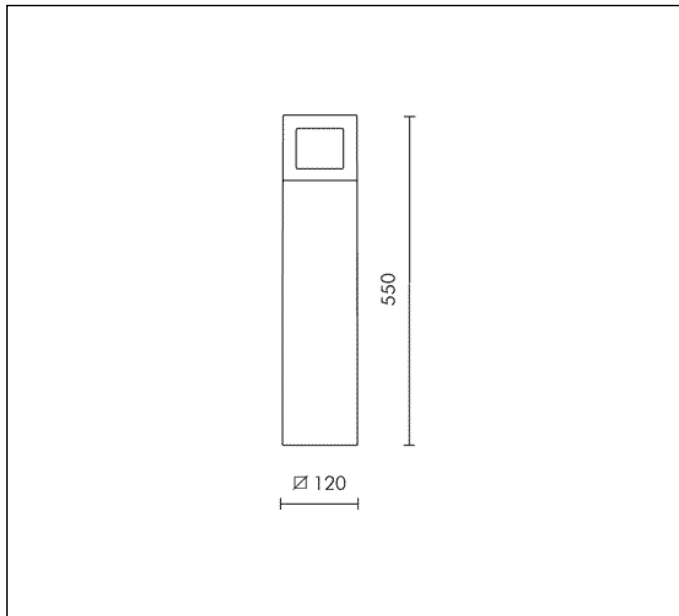
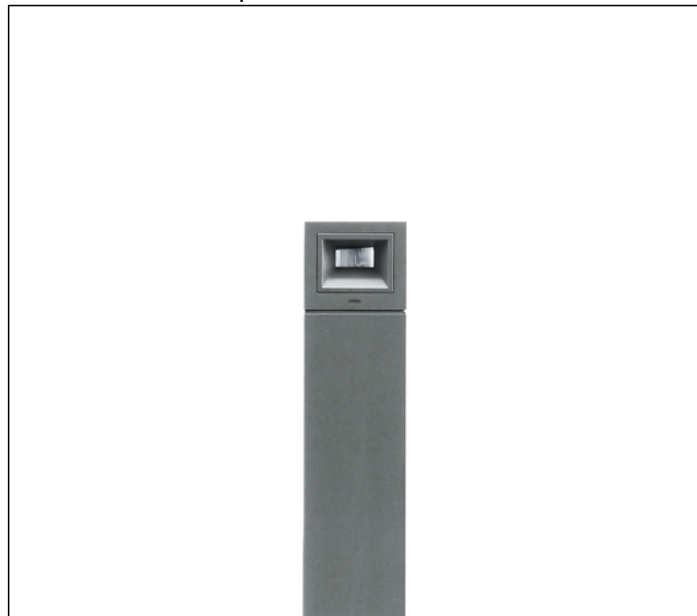

4 MODULES LED 4000K 230V 821lm 8.4W CRI 90

Rated luminaire luminous flux: 137lm

Rated input power: 11W

Luminaire efficacy: 12lm/W

Electronic ballast 220÷240V 50/60Hz

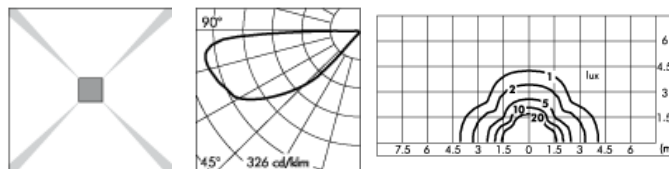

\* Photometric measured using WHITE LED 3000K



### PRODUCT TYPE

Bollard fitting. IP rating IP 65

### MATERIAL CHARACTERISTICS

Extruded EN AW-6060 aluminium profile, die-cast EN AB-47100 aluminium housing with high corrosion resistance. Stone wash surface treatment prior to painting process. A4 grade Stainless Steel screws with 2,5-3% molybdenum content which increases the resistance against corrosion. Pre treated Silicone Gaskets. Painting Process : 3 Step Process

1) Surface treatment with BONDERITE. A heavy metal free chemical surface treatment containing ceramic nano particles giving a cohesive, inorganic and highly dense protective coating. 2) PRE POLYMERIZATION a process of introducing an epoxy primer with excellent characteristics to the paint which also offers very high resistance to oxidation due to its Zinc content. 3) POLYMERIZATION a process with the application of polyester powder with high resistance against UV rays and harsh weather conditions. Resistance test protection for Marine applications for 1200h. Mechanical resistance IK 10

### VERY SOLID BOLLARD

The accessory flange when rooted into the ground provides extra protection and prevents the bollard from being knocked over. The bollard head component is made from a one piece ALUMINIUM DIE-CAST. The diffuser is a single piece of waterproof polycarbonate that assures a good mechanical resistance. The 4 angled sides provide a very rigid solution.

### LIGHTING PERFORMANCE

The optic system combines 2 elements: 1) reflector 99.98% pure aluminium; 2) clear polycarbonate reeded diffuser The reflector is placed above the lamp to maximize the light output, capturing any indirect light, reflecting the rays back down towards the prismatic lens. An ENLONGATION LENS provides even horizontal light distribution at ground level. The eye perception is even lighting when the luminaire is in a real environment. Lamp fixed position . LOR -- The 4 LED circuits have been developed around an anodized aluminium x-shaped structure, specifically designed to house one LED circuit for each window of the bollard. This structure combined to the LED circuit is an efficient heat dissipator. 4 windows version are delivered as standard but, on request, can be delivered with: 1 window; 2 windows; 3 windows; If the window is closed the design is always clean.

### WIRING

Supplied with 1m cable type H07RN-F and IP67 fast connector. The connector must be connected at the supply line (Ø 12÷16 mm). Isolation: CLASS II . Available colours: Aluminium grey (cod.14). Weight: 4 Kg Glow Wire test: --

L.E.D circuit included.

### CUBIKS REGISTERED DESIGN

This luminaire contains built-in LED modules with energy class: A, A+, A++. In case of damage or malfunction please contact the manufacturer to receive additional instructions on how to replace and relative spare parts to order. The LED modules cannot be handled in the luminaire by the end user (Regulation UE 874/2012).

LED circuit boards are engineered accordingly to actual Lumen Maintenance regulation (LM80) and Technical Memorandum (TM21) where uniformity and quality of light is 50.000 hours referred to L70 B20 Ta 25°C.

Lifecycle refers to LED circuit boards only, all others components of the luminaire are excluded.

**TECHNICAL DATA SHEET ART. S.5314N - MINICUBIKS LED  
INCLUDED ACCESSOIRES**



**FAST CONNECTOR INCLUDED**

**ACCESSORIES**



**S.6309**

**FLANGE FOR BOLLARD**

Ø 120 mm flange to be fixed in concrete with stainless steel screws for fixing in the ground.

**Further information**

**FIXING BASE**

