

TECHNICAL DATA SHEET ART. S.4654 + S.4350 - STRIP BOLLARD

Available until 31/12/2017 but subject to stock levels

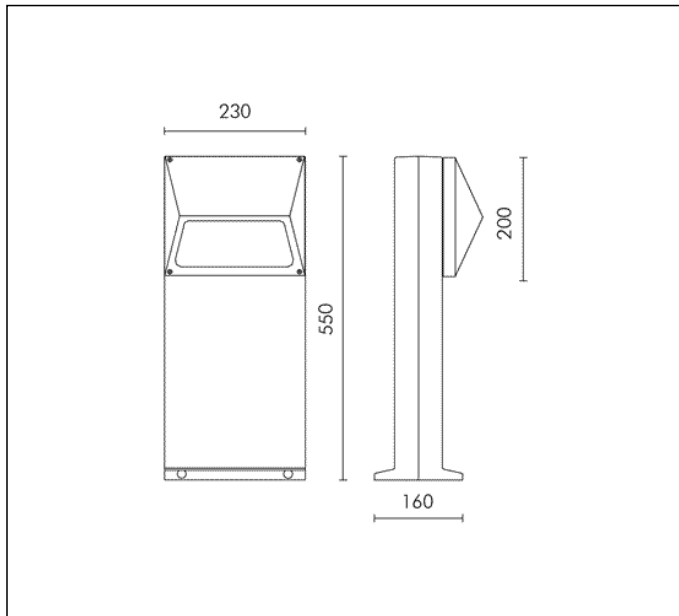

MODULES LED 6000K 230V 1180lm 10.5W CRI 75

Rated luminaire luminous flux: 325lm

Rated input power: 14W

Luminaire efficacy: 23lm/W

Electronic ballast 220÷240V 0/50/60Hz

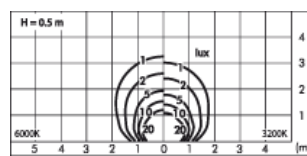
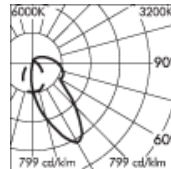
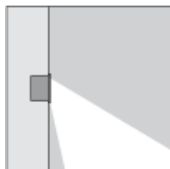

CE

PRODUCT TYPE

Wall mounted luminaire. IP rating IP 55

MATERIAL CHARACTERISTICS

Aluminium die cast housing in EN AB-47100 (low copper content) and extruded EN AW-6060 with high resistance against corrosion. Stone wash surface treatment prior to painting process. A4 grade Stainless Steel screws with 2,5-3% molybdenum content which increases the resistance against corrosion. Silicone gaskets. Painting Process : 3 Step Process

1) Surface treatment with BONDERITE. A heavy metal free chemical surface treatment containing ceramic nano particles giving a cohesive, inorganic and highly dense protective coating. 2) PRE POLYMERIZATION a process of introducing an epoxy primer with excellent characteristics to the paint which also offers very high resistance to oxidation due to its Zinc content. 3) POLYMERIZATION a process with the application of polyester powder with high resistance against UV rays and harsh weather conditions. Resistance test protection for Marine applications for 1200h. Mechanical resistance IK 06

LIGHTING PERFORMANCE

Reflector in 99.98% pure anodized aluminium . Opal toughened glass diffuser. LOR --

INSTALLATION AND MAINTENANCE

Installation is easy, thanks to the polypropylene recessing box. The luminaires are fixed in therecessing box by stainless steel screws. The glass diffuser is affixed directly onto the cover with silicone. The cover disguises the recessing box edge, so holes and any wallimperfections are invisible.

WIRING

Double cable entries. Isolation: CLASS I . Available colours: Aluminium grey (cod.14). Weight: 2 Kg Glow Wire test: 850°C

Lamp included.

This luminaire contains built-in LED modules with energy class: A, A+, A++. In case of damage or malfunction please contact the manufacturer to receive additional instructions on how to replace and relative spare parts to order. The LED modules cannot be handled in the luminaire by the end user (Regulation UE 874/2012).

LED circuit boards are engineered accordingly to actual Lumen Maintenance regulation (LM80) and Technical Memorandum (TM21) where uniformity and quality of light is 50.000 hours referred to L70 B20 Ta 25°C.

Lifecycle refers to LED circuit boards only, all others components of the luminaire are excluded.

EMERGENCY VERSIONS

The fittings operates both on AC (50/60Hz) and DC (0Hz) voltage.