

TECHNICAL DATA SHEET ART. S.3963 - MINISLOT AVANT-GARDE SYMMETRIC

Available until 31/12/2017 but subject to stock levels

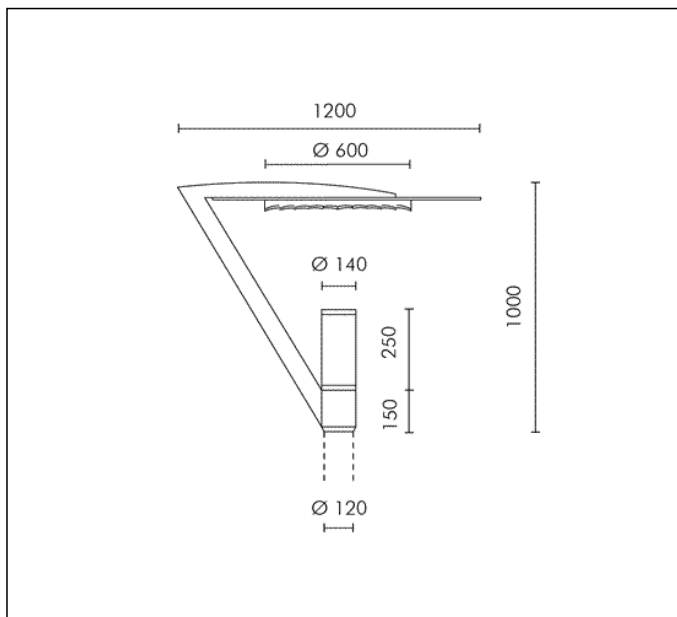

HIT-CRI 70W CLEAR G12 6600lm
 Rated luminaire luminous flux: 3036lm
 Rated input power: 84W
 Luminaire efficacy: 36lm/W (LOR: 46%)
 Magnetic transformer 230V 50Hz
 EEI=A3, LOSSES=12.5W

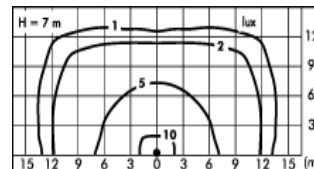
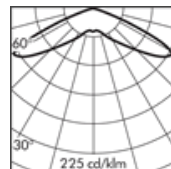
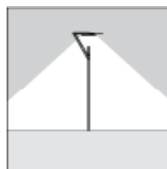

CE □ ◆ ▲ ▲ IP 65 **A+**

PRODUCT TYPE

Post top luminaire. IP rating IP 65

MATERIAL CHARACTERISTICS

Aluminium die cast housing in EN AB-47100 (low copper content) and extruded EN AW-6060 with high resistance against corrosion. The holder is made of steel for mechanical strength and resistance to heavy atmospheric stress. The mirrors are affixed to an ultra-light plastic disk. The combined weight of mirror and polycarbonate disk is only 15 kg. Stone wash surface treatment prior to painting process. A4 grade Stainless Steel screws with 2,5-3% molybdenum content which increases the resistance against corrosion. Silicone gaskets. Painting Process : 3 Step Process

1) Surface treatment with BONDERITE. A heavy metal free chemical surface treatment containing ceramic nano particles giving a cohesive, inorganic and highly dense protective coating. 2) PRE POLYMERIZATION a process of introducing an epoxy primer with excellent characteristics to the paint which also offers very high resistance to oxidation due to its Zinc content. 3) POLYMERIZATION a process with the application of polyester powder with high resistance against UV rays and harsh weather conditions. Resistance test protection for Marine applications for 1200h. Mechanical resistance IK 08

LIGHTING PERFORMANCE

The optical system comprises : 1) Primary Reflector in 99.98% pure anodized aluminium inside the cylinder; 2) Secondary reflector with 88 multi-faceted mirrors, in polymers covered with 99.98% pure aluminium: the process of laying the aluminium layer down on the reflector's polymeric structure is carried out in a vacuum to provide exceptional reflective properties. A thin, transparent film provides protection from UV rays and environmental agents. The indirect light element creates a very pleasant light halo effect without any glare. Clear toughened glass 8 mm thick. LOR 46%

POLE CONNECTION

Pole head in painted aluminium with \varnothing 120 mm connection.

WIRING

Single cable entry sealed with B component epoxy resin, wired internally protected by silicon sheaths. Fast connector IP67 (\varnothing 6÷12 mm) supplied as standard for single cable connection. Isolation: CLASS II. Available colours: Aluminium grey (cod.14). Weight: 60.5 Kg Glow Wire test: -- Exposed windage area : 0,38 m²

Lamp not included.

MINISLOT AVANT-GARDE REGISTERED DESIGN

This luminaire is compatible with bulbs of the energy classes: **A+** (Regulation UE 874/2012).

TECHNICAL DATA SHEET ART. S.3963 - MINISLOT AVANT-GARDE SYMMETRIC ACCESSORIES

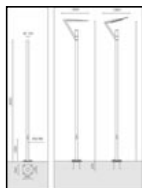

S.2848

Ø 120mm CYLINDRICAL POLE WITH BASE

Cylindrical shaped poles consisting of: straight circular section shaft, Ø 120mm, 3mm in thickness, total length 6,00m , single section built by using longitudinally welded tubes by induction welding (ERW) UNI EN 10219-2-ISO 4200

Suitable for installation to a planted root flange through a base plate 250x250x12mm in steel S355JO : Suggested reinforced concrete footstall dimension 1x1 h 0,7m. Footstall dimension can be calculated according to your country norms and ground properties.

The grade of steel used is S235JR (Fe360B) with material characteristics as per normative UNI EN 10025; The surface protection treatment is done through hot dip galvanization.

Painting Process: PRE POLYMERIZATION a process of introducing an epoxy primer with excellent characteristics to the paint which also offers very high resistance to oxidation due to its Zinc content. POLYMERIZATION a process with the application of polyester powder with high resistance against UV rays and harsh weather conditions. Resistance test protection for Marine applications for 1500h.

MINISLOT AVANT-GARDE INSTALLED ON S.2848 POLE:

Finished product total height = 7.13 m

Cap COPE2826PVC.09 already installed.

TO BE USED WITH THE FOLLOWING ACCESSORIES:

S.2840 PLANTED ROOT for CYLINDRICAL POLE

S.2809 POLE BASE COVER

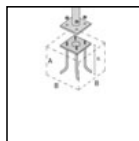

S.2840

PLANTED ROOT for CYLINDRICAL POLE

h = 470 mm and bolts in galvanized steel with M16 threads. Suggested reinforced concrete footstall dimension:

A = 0.7 m

B = 1 m

Footstall dimension can be calculated according to your country norms and ground properties.

Footstall dimension can be calculated according to your country norms and ground properties.

TO BE USED WITH THE FOLLOWING ACCESSORIES:

S.2846, S.2848 CYLINDRICAL POLE



S.2841

ACCESSORY AGAINST LIGHT POLLUTION

With this accessory the light emission above 90° is 0%



S.2809

POLE BASE COVER

For pole with base and pole to be buried Ø102mm or Ø120mm.

Die-cast aluminium housing.