

TECHNICAL DATA SHEET ART. S.3542 - MICROTECHNO SPOT

Available until 31/12/2017 but subject to stock levels

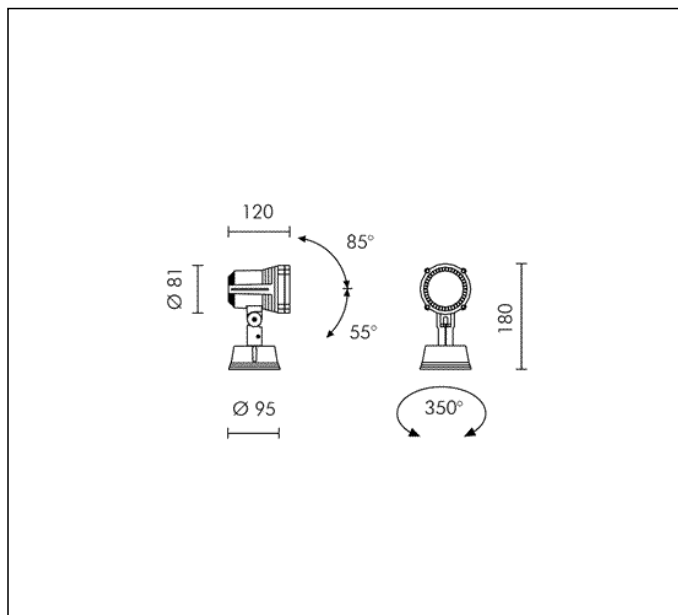

QT12 35W GY6,35 12V
 Rated luminaire luminous flux: 228lm
 Rated input power: 36.3W
 Luminaire efficacy: 6lm/W (LOR: --)
 Electronic ballast 220÷240V 50/60Hz

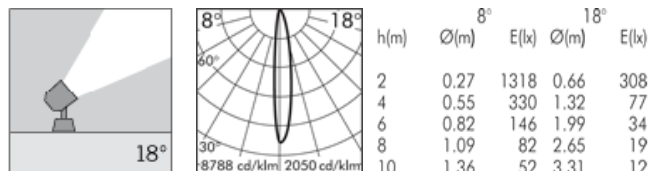

PRODUCT TYPE

Projector. IP rating IP 65

MATERIAL CHARACTERISTICS

Aluminium die cast housing in EN AB-47100 (low copper content) with high resistance against corrosion. Stone wash surface treatment prior to painting process. A4 grade Stainless Steel screws with 2,5-3% molybdenum content which increases the resistance against corrosion. Pre treated Silicone Gaskets. Painting Process : 3 Step Process

1) Surface treatment with BONDERITE. A heavy metal free chemical surface treatment containing ceramic nano particles giving a cohesive, inorganic and highly dense protective coating. 2) PRE POLYMERIZATION a process of introducing an epoxy primer with excellent characteristics to the paint which also offers very high resistance to oxidation due to its Zinc content. 3) POLYMERIZATION a process with the application of polyester powder with high resistance against UV rays and harsh weather conditions. Resistance test protection for Marine applications for 1200h. 4 mm thick tempered glass diffuser. Mechanical resistance IK 06 Maximum load capacity --

LIGHTING PERFORMANCE

The lathed anodized reflector is composed of 99,98% pure anodized aluminium with a bright polish finish (with HIT lamp version). LOR --

INSTALLATION AND MAINTENANCE

The projector is supplied with graduated ferrules on both sides of the fitting. Power supply connection takes place by means of a disconnecting switch. This facilitates installation on walls because you can attach the base and do the wiring, positioning the complete unit at the end of the installation.

WIRING

Single cable entry. Isolation: CLASS I . Available colours: Aluminium grey (cod.14), Anthracite grey (cod.24). Weight: 0.8 Kg Glow Wire test: 850°C

Lamp not included.

This luminaire is compatible with bulbs of the energy classes: C (Regulation UE 874/2012).

TECHNICAL DATA SHEET ART. S.3542 - MICROTECHNO SPOT ACCESSORIES



**S.3520
PROTECTIVE GRILL**
In die-cast aluminium. To be installed instead of the aluminium ring holder.

Available until 31/12/2017 but subject to stock levels



**S.3523
VISOR**
In die-cast aluminium. To be installed instead of the aluminium ring holder.



**S.3524
STAKE**
In POLYPROPYLENE.
Colour: black (code 09)
Length = 270 mm
The 90 mm upper part must stay above ground level, according to the norm.
(not suitable for REEF bollard versions)

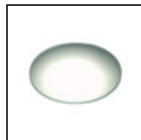

**S.3500
WIDE BEAM LENS**
It enlarges the standard beam:
It enlarges the standard beam from 18° to ~ 36°.



**S.3501
ELLIPSOIDAL BEAM LENS**
It modifies the beam:
For versions with 8° reflector. It modifies the beam from 8° to ~ 20°x60°.

Further information

FIXING BASE

