

ELLISSE PENDANT TRIPLE

Federico Palazzari

Collection of LED pendants, floor/wall lamps available in different versions: major, minor, double, triple and mega provides a direct or indirect diffused light.

In extruded aluminum in different versions: matt lacquered in the finishes, white, black and gold, natural polished and gold polished anodized.

Equipped with an opal diffuser.

The lamps are made using a proprietary extrusion coupling technology.

Ellisse Major is also available as floor or wall versions and is provided with a black marble base or a wall hook accessory.

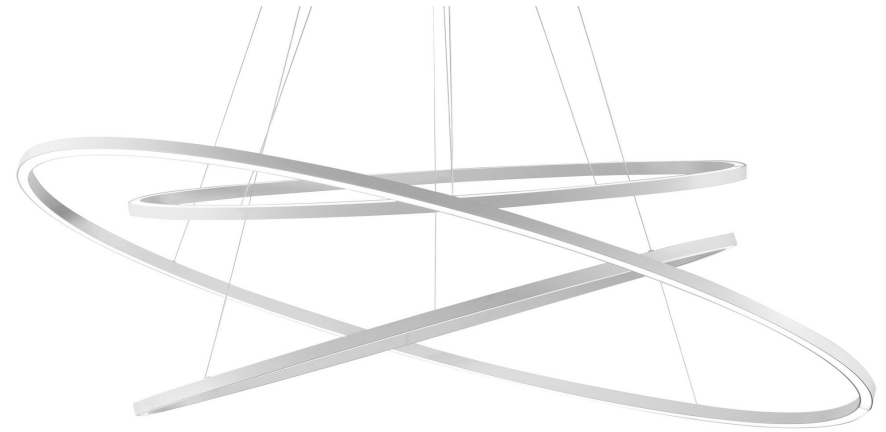

LED 2700K

LAMPING

Source	linear LED
Total power	94W
Emission	diffused orientable uplight(minor), diffused orientable downlight (major/minor)
Switching	dimnable 1-10V
Tension	110/240V
Color temperature	2700K
Luminous flux	1325+2050+1325lm
Typ CRI	85
Materials	Aluminium
Notes	adjustable cable length from 2,5 to 0,4 m, DALI version on request, TRIAC VERSION on request
Net lamp weight	5 kg

Codes

ELP LW2 57
ELP LN2 57
ELP LL2 57
ELP LO2 57
ELP LGW 57

Structure/Diffuser

white/white
black/white
polished aluminium/white
gold painted/white
gold polished anodized/white

PACKAGE

Package 01 Dimension: 80x150x15 cm / Gross weight: 7,5 kg

Certificazioni

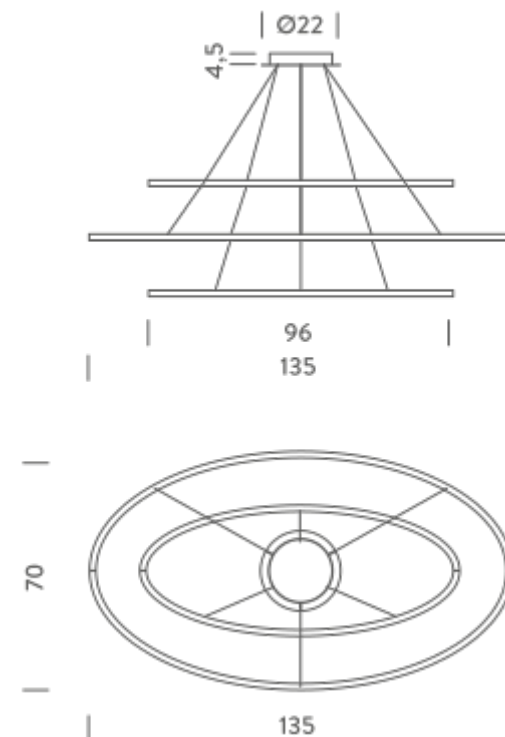

LED 3000K

LAMPING

Source	linear LED
Total power	94W
Emission	diffused orientable uplight(minor), diffused orientable downlight (major/minor)
Switching	dimnable 1-10V
Tension	110/240V
Color temperature	3000K
Luminous flux	1325+2050+1325lm
Typ CRI	85
Materials	Aluminium
Notes	adjustable cable length from 2,5 to 0,4 m, DALI version on request
Net lamp weight	5 kg

Codes

ELP LWW 57
ELP LNW 57
ELP LLW 57
ELP LOW 57

Structure/Diffuser

white/white
black/white
polished aluminium/white
gold painted/white

PACKAGE

Package 01 Dimension: 15x80x150 cm / Gross weight: 7,5 kg

Certificazioni

