

FLOS

USB ROUND 2L W-W

| | |
|-------------------|-----------------------------|
| Lamps description | 2 x QR-CBC-5I GU5.3 Max 50W |
| Voltage (V) | 12 |
| Environment | Indoor |

OPTICAL

| | |
|-----------------------------|------------|
| Aiming | Fixed |
| Light distribution symmetry | Asymmetric |

ELECTRICAL

| | |
|--------------------------|---------------|
| Transformer availability | Separate item |
| Transformer mounting | Remote |
| Transformer type | Electronic |
| Emergency | Without |
| Insulation class | Class III |

PHYSICAL

| | |
|-------------|---|
| Weight (kg) | 3 |
|-------------|---|



USB Round 2L W-W

designed by FLOS Soft Architecture

Recessed luminaire for 12V halogen lamp. 220/240V, 50/60Hz. Adjustable by means of "leading and trailing edge". Remote transformer not included.

SA.3020.I Raw

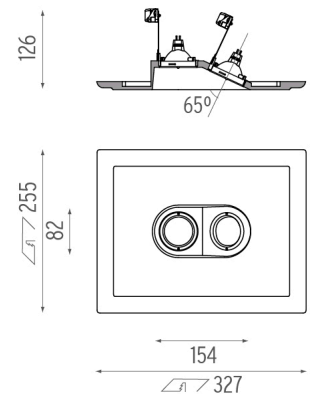

CERTIFICATIONS



USB Round 2L W-W . Accessories

Transformer



60.8139

Electronic transformer 20/105W

Electronic transformer 12V.
220/240V, 50/60Hz.
Adjustable by means of
"leading and trailing edge".

USB Round 2L W-W . Lamps



QR-CBC-51 50W GU5.3

Lamp Watt:

50 W

Lamp category:

Halogen low voltage

Socket:

GU5.3

Lamp type:

QR-CBC-51



USB Round 2L W-W

designed by FLOS Soft Architecture

Recessed luminaire for 12V halogen lamp. 220/240V, 50/60Hz. Adjustable by means of "leading and trailing edge". Remote transformer not included.

SA.3020.I Raw

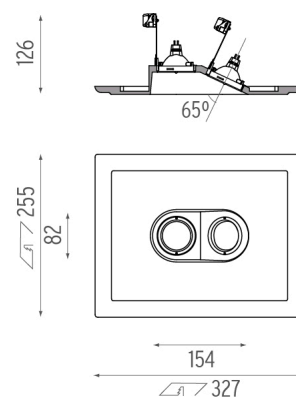

CERTIFICATIONS

