

LIGHT SNIPER ADJUSTABLE ROUND

Number of heads	1
Mounting	Ceiling recessed
Lamps description	Phosphor LED 9W 800 lm 3000K CRI 98
Luminaire luminous flux	Extreme Cut-off. See reference number
Voltage (V)	220/240
Environment	Indoor

OPTICAL

Light controller description	Bare lamps
Aiming	Adjustable
Light distribution symmetry	Symmetric
Beam angle	23°

ELECTRICAL

Transformer availability	Included
Transformer mounting	Remote
Transformer type	Electronic
Emergency	Without
Insulation class	Class II

PHYSICAL

Cutout diameter (mm)	90
Diameter (mm)	100
Recessed depth (mm)	125
Construction material	Aluminium
Weight (kg)	0,51



Light Sniper Adjustable Round
designed by FLOS Architectural

High-performance embedded light fixture for LED light source. Remote 220-240V power supply included.

	03.4683.06A - 125lm	Chrome
	03.4683.GLA - 125lm	Gold
	03.4683.14A - 125lm	Matt black

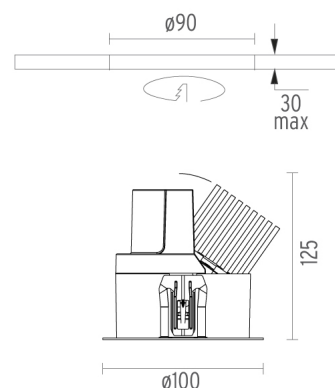

CERTIFICATIONS

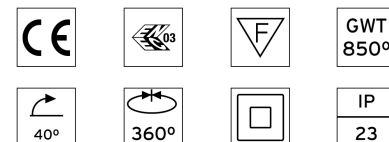

Light Sniper Adjustable Round . Accessories

Mounting



○ 08.8239.00B

Flush ceiling round frame accessory



08.8243.00

08.8243.00.5U

08.8243.00.1U

Ceiling protector accessory.

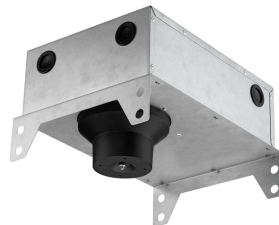

08.8250.00

Concrete installation can.



Light Sniper Adjustable Round
designed by FLOS Architectural

High-performance embedded light fixture for LED light source. Remote 220-240V power supply included.

- 03.4683.06A - 125lm Chrome
- 03.4683.GLA - 125lm Gold
- 03.4683.14A - 125lm Matt black

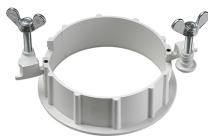

○ 08.8229.30A

Ceiling protector accessory. Round

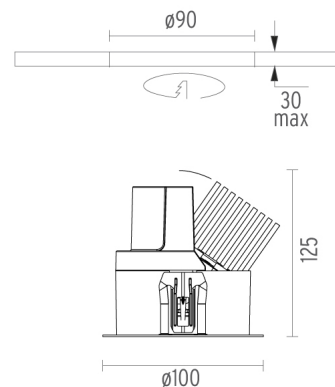

CERTIFICATIONS

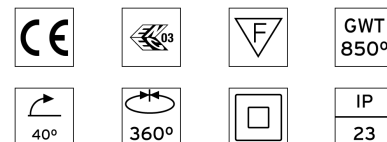

Light Sniper Adjustable Round . Lamps



Phosphor LED

Lamp category:
LED

Lamp type:
Phosphor LED



Light Sniper Adjustable Round
designed by FLOS Architectural

High-performance embedded light fixture for LED light source. Remote 220-240V power supply included.

- 03.4683.06A - 125lm Chrome
- 03.4683.GLA - 125lm Gold
- 03.4683.14A - 125lm Matt black

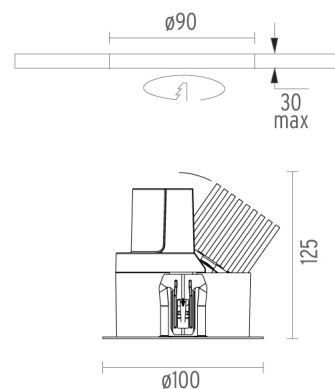

CERTIFICATIONS

