

MAXISPY ON 95 DIM1

DEEL
PARTIE
TEIL
PART
PARTE
PARTE **A**

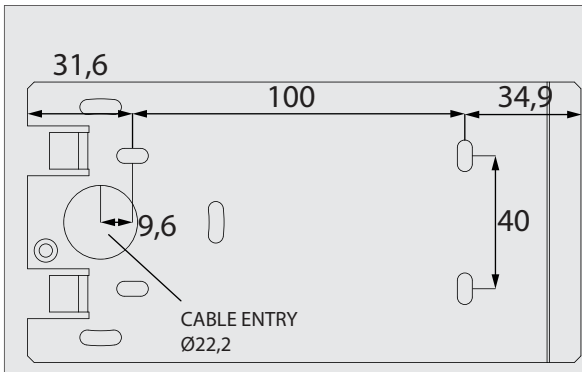
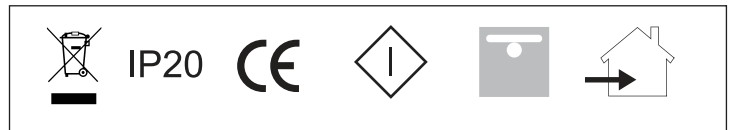
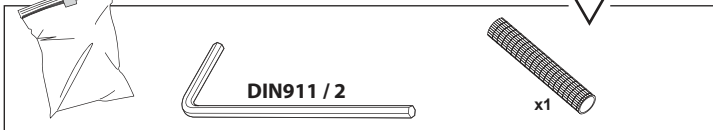
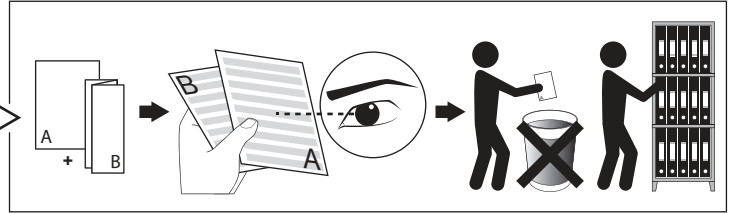
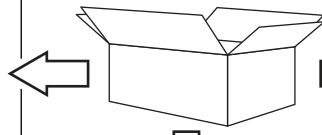
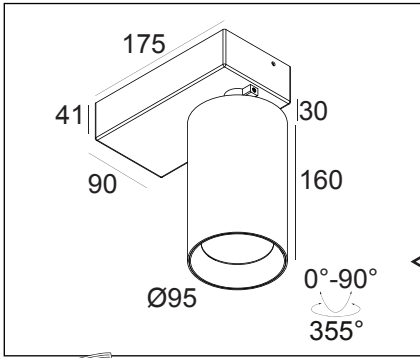

REQUIREMENTS

MAXISPY ON 95 TUBE	414 08 00
REFLECTOR 20°	414 99 20
REFLECTOR 38°	414 99 38
REFLECTOR 50°	414 99 50

ACCESSORIES

HONEYCOMB 74	414 04 01
SOFTENING LENS 74	414 04 04

1-10V DIMMING	
U	110-240V
P _o	37,9W
I _o	1050mA

IP20

Beschermd tegen vaste voorwerpen die groter zijn dan 12 mm
 Protégé contre les objets solides de plus de 12 mm
 Geschützt gegen Festkörper größer als 12 mm
 Protected against solid objects greater than 12 mm
 Protegido contra objetos sólidos superiores a 12 mm
 Protetto contro oggetti solidi più grandi di 12 mm

Voorzien van aardingsaansluiting
 Avec mise à la terre
 Ausgerüstet mit Erdungsanschluss
 Provided with grounding
 Con la toma de tierra
 Con presa a terra

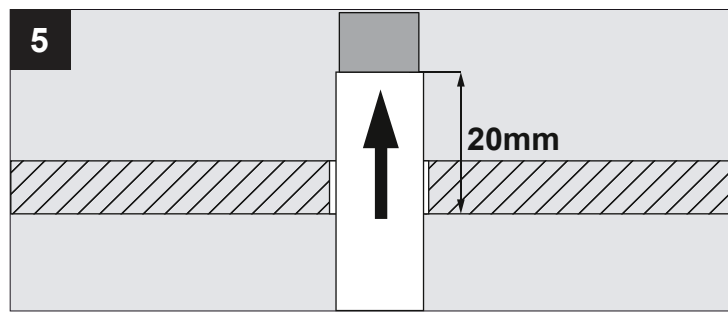
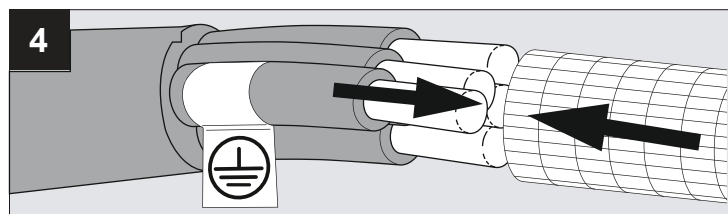
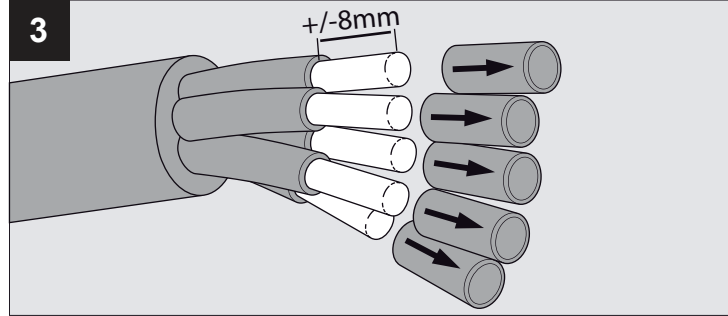
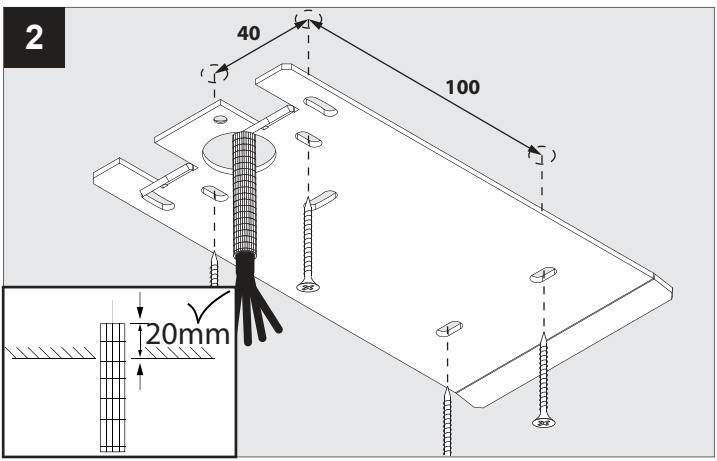
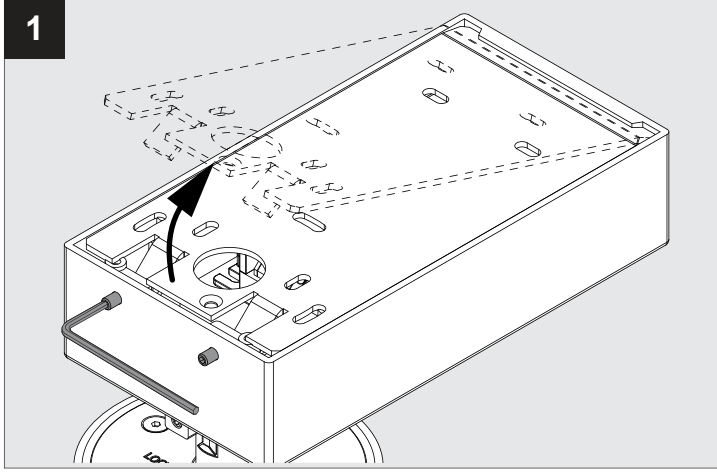

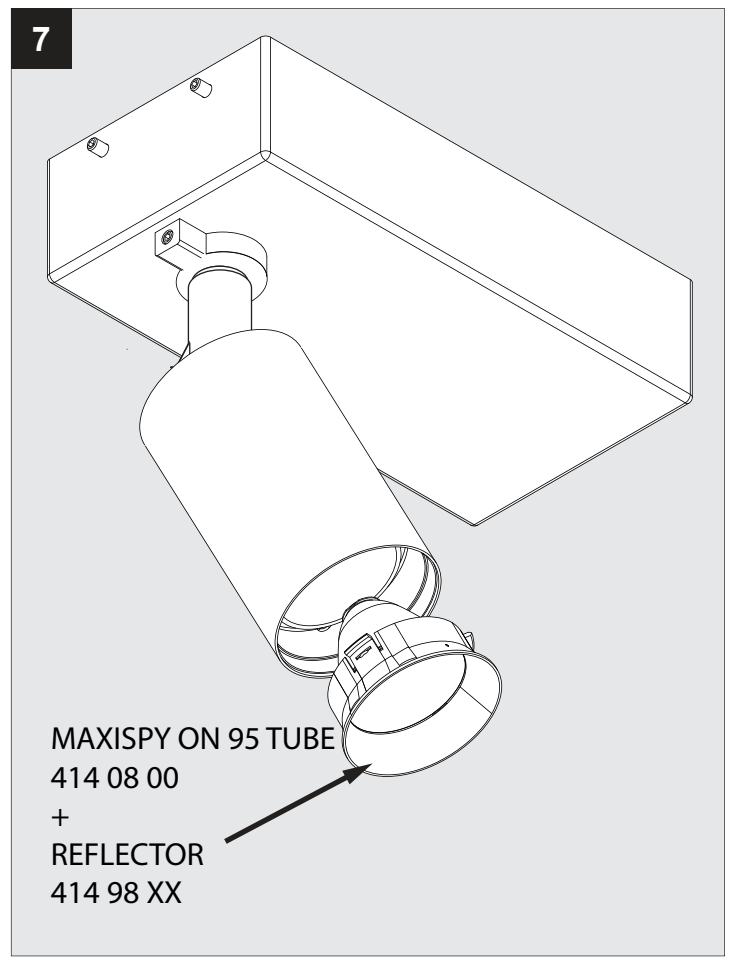
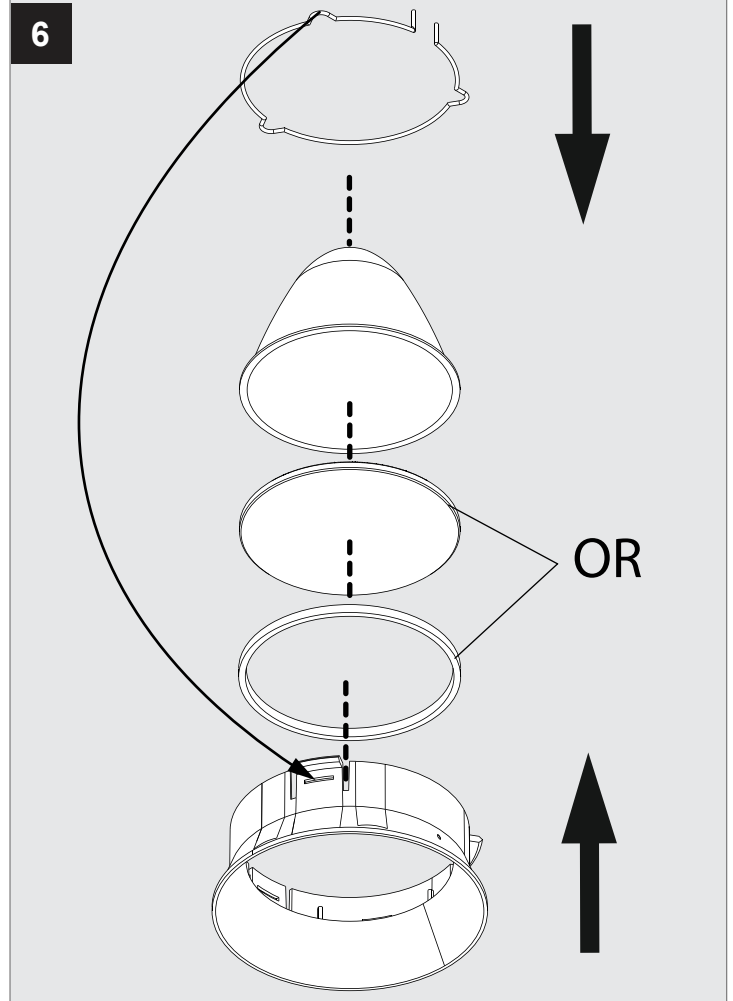
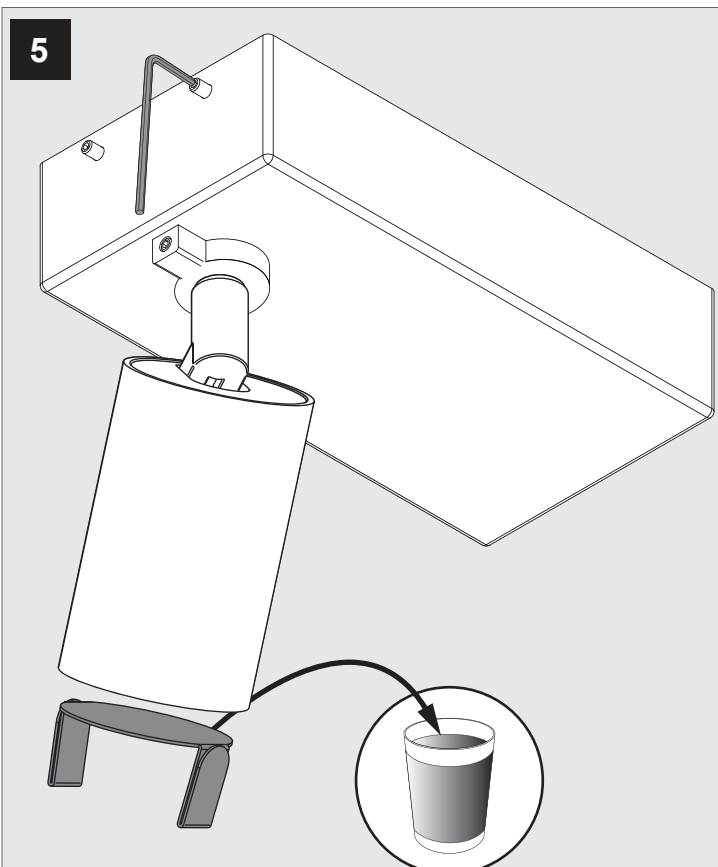
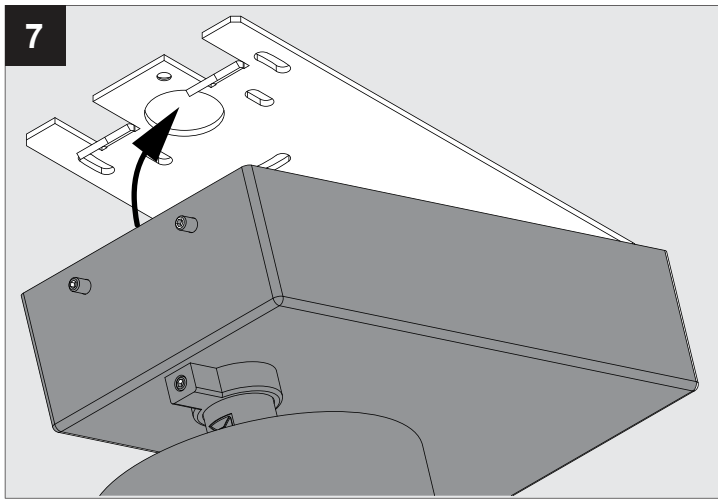
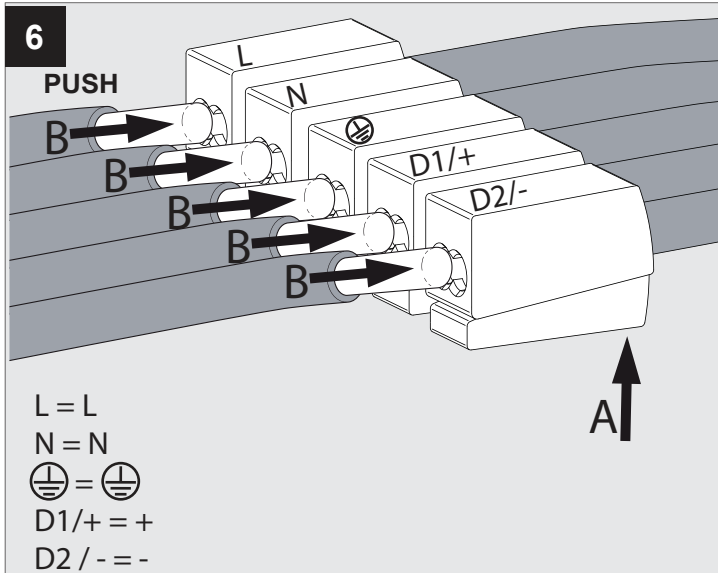

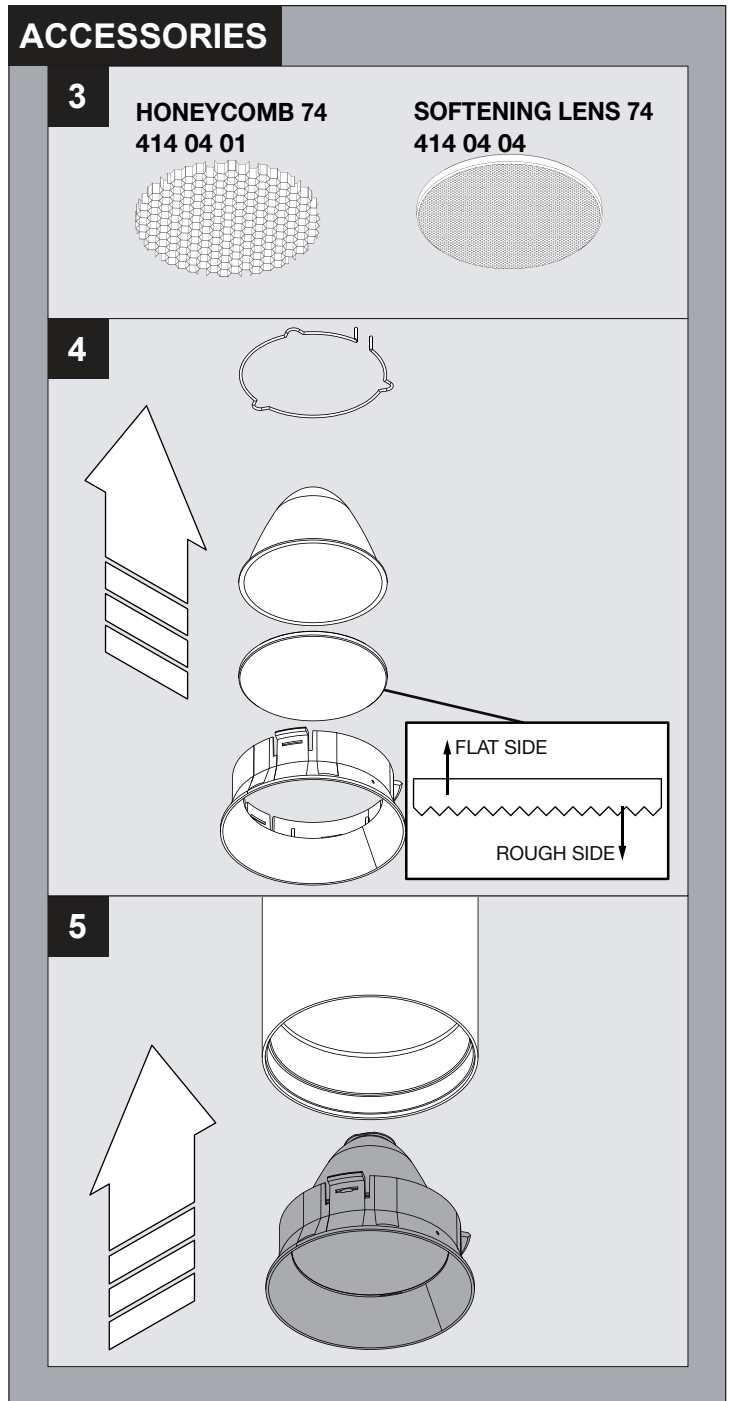
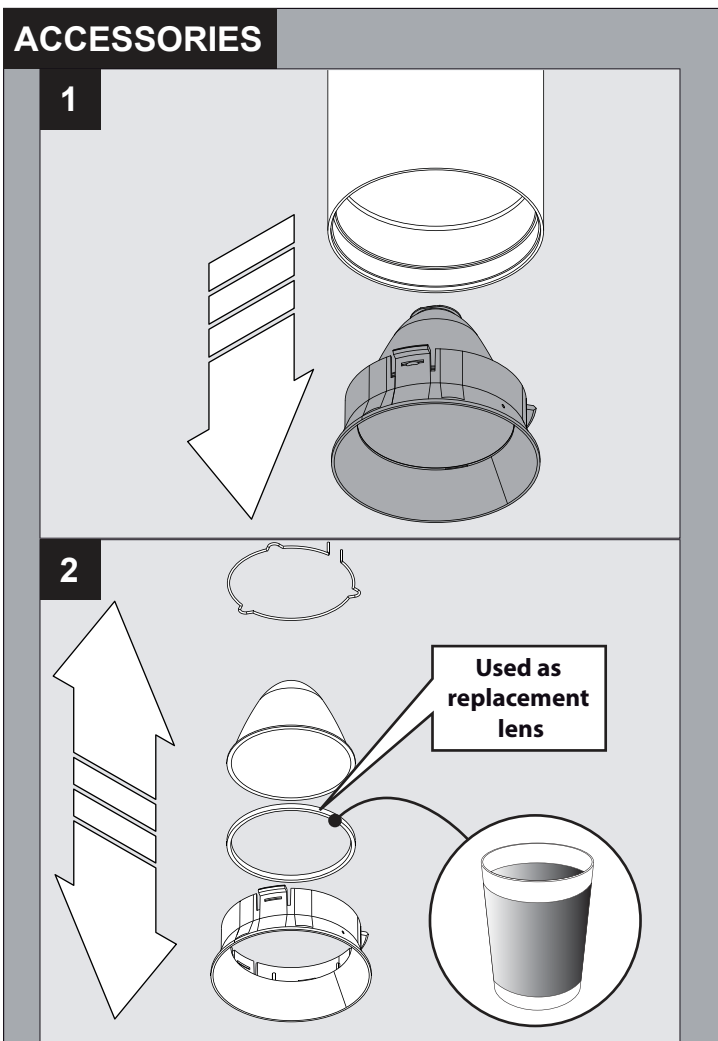
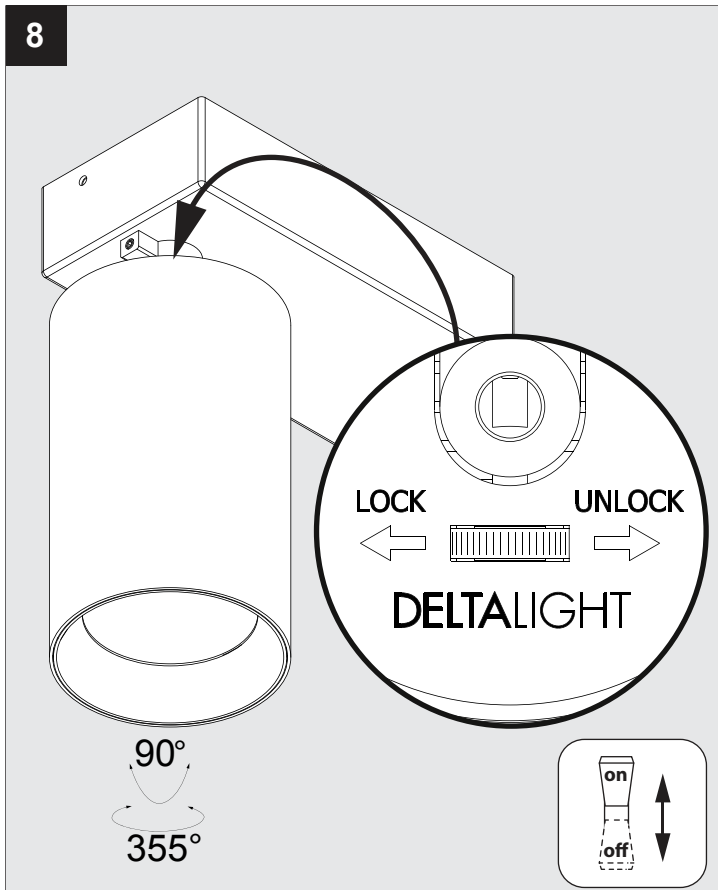

De verlichtingsbron van dit verlichtingstoestel zal enkel door de fabrikant of door de fabrikant aangestelde installateur vervangen worden.

La source lumière de cet appareil ne sera remplacée que par l'entreprise ou par un agent reconnu.

Das enthaltene Leuchtmittel sollte nur durch entsprechendes Fachpersonal ersetzt werden.

The light source contained in this luminaire shall only be replaced by the manufacturer or his service agent.

La fuente de iluminación que tiene esta luminaria sólo puede remplazarse por el fabricante o por un instalador autorizado.

La sorgente luminosa incorporata in questo apparecchio può essere sostituita solo dal produt tore, da un suo centro assistenza oppure da una persona in possesso della necessaria abilitazione.