

MIDISPY CLIP

DEEL
PARTIE
TEIL
PART
PARTE
PARTE **A**

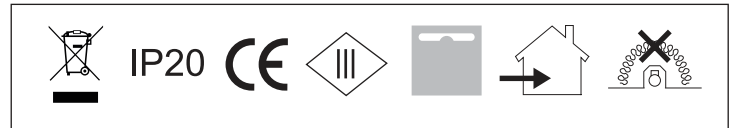
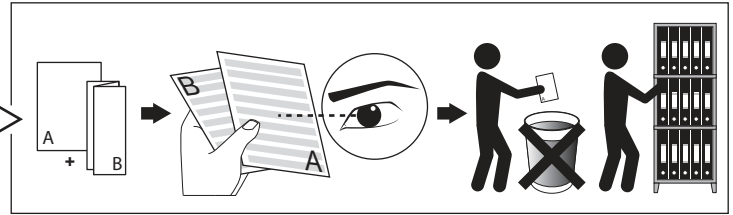
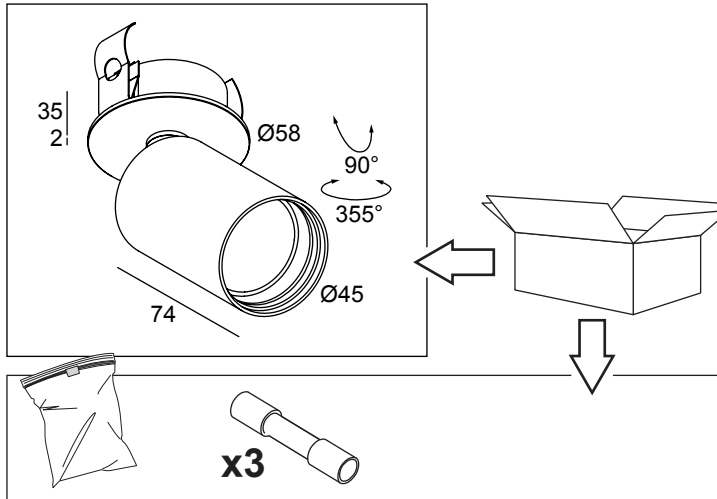

50 x 40

		mm
	A	Ø50
	B	40
	C	Ø58
	D	Max. 12

REFLECTOR WFL-40°

I_o	350mA	OR	500mA
P_o	6,4W		9,5W
U_f Typical	16,9V-DC		17,3V-DC

REQUIREMENTS
MIDISPY TUBE

OPTIONS
MOUNTING KIT FLUSH SPY
LED POWER SUPPLY 350-500mA-DC / DIM

IP20

Beschermd tegen vaste voorwerpen die groter zijn dan 12 mm
Protégé contre les objets solides de plus de 12 mm
Geschützt gegen Festkörper größer als 12 mm
Protected against solid objects greater than 12 mm
Protegido contra objetos sólidos superiores a 12 mm
Protetto contro oggetti solidi più grandi di 12 mm



Enkel geschikt voor toestellen op zeer lage spanning (minder dan 50 V AC)
Convient uniquement pour les produits à très basse tension (moins de 50 V AC)
Geeignet für Güter mit sehr niedriger Spannung (unter 50 V AC)
Only suited for goods at very low voltage (below 50 V AC)
Se recomienda únicamente para aquellos productos de tensión muy baja (menos de 50 V AC)
Vale unicamente per i prodotti a tensione molto bassa (inferiore a 50 V AC)

1

50 x 40

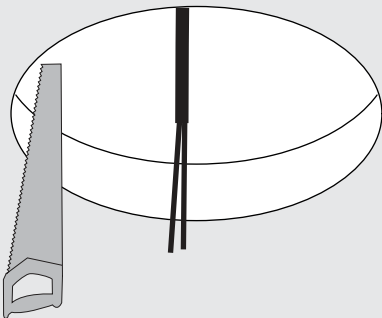

OR

OPTIONS

MOUNTING KIT FLUSH SPY
414 90 01

ØKITx 40

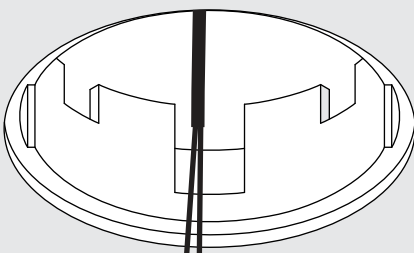

2

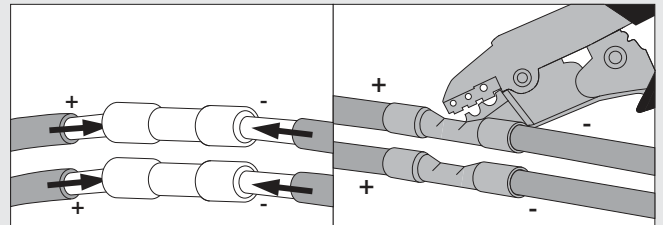

ELECTRICAL CONNECTION ⚠

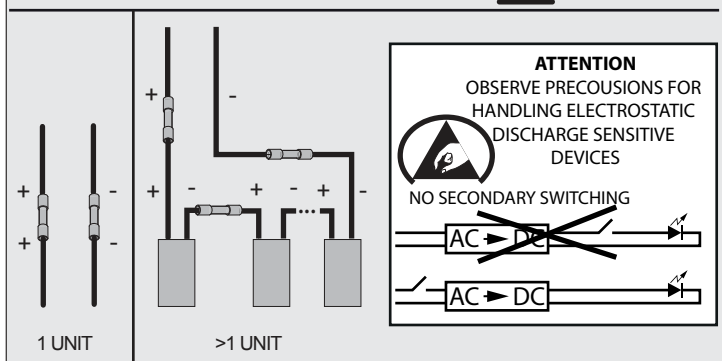

3

50 x 40

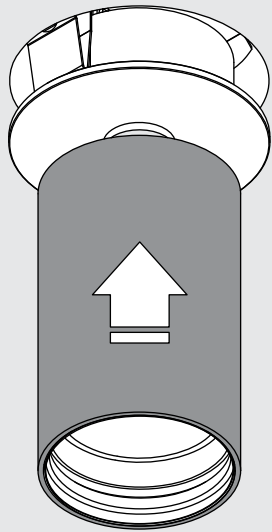

OPTIONS

MOUNTING KIT FLUSH SPY
414 90 01

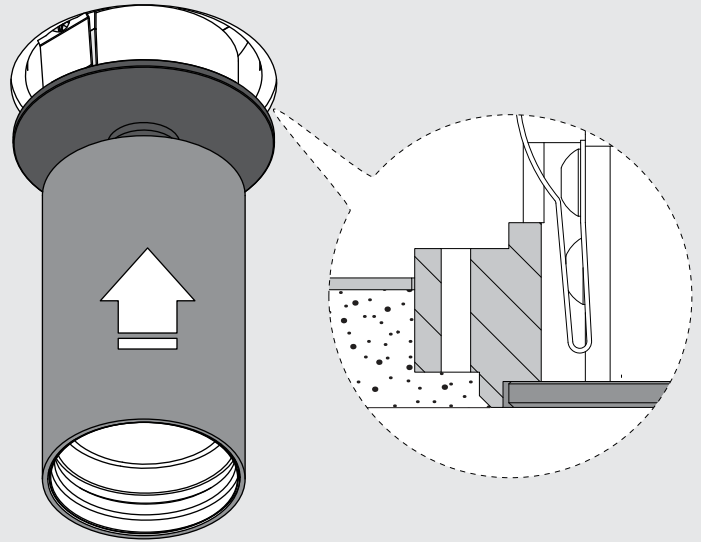

4

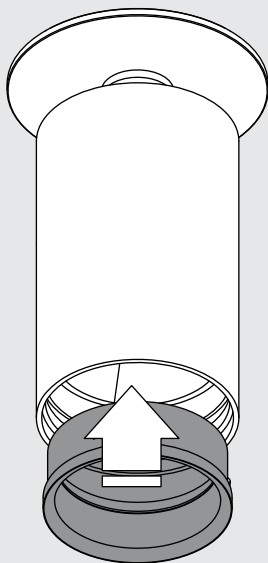

CLICK!

REQUIREMENTS
MIDISPY TUBE
414 03 00

5

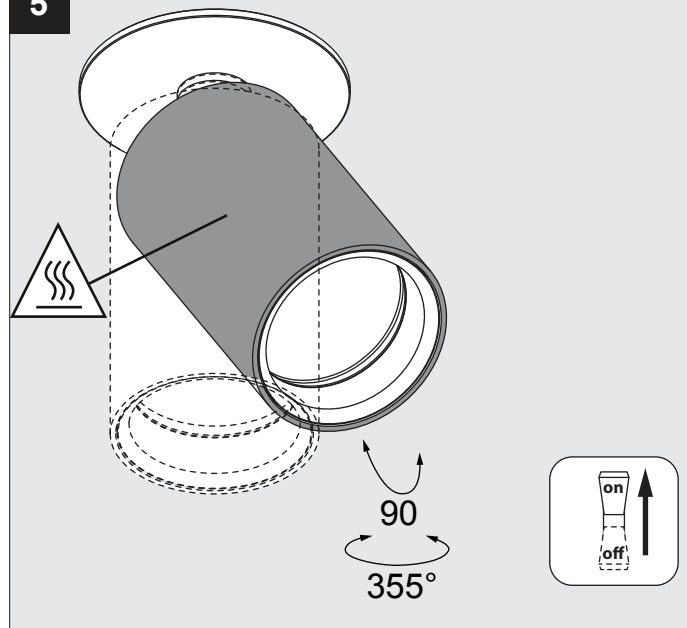

De verlichtingsbron van dit verlichtingstoestel zal enkel door de fabrikant of door de fabrikant aangestelde installateur worden vervangen.

La source lumière de cet appareil ne sera remplacée que par l'entreprise ou par un agent reconnu.

Das enthaltene Leuchtmittel sollte nur durch entsprechendes Fachpersonal ersetzt werden.

The light source contained in this luminaire shall only be replaced by the manufacturer or his service agent.

La fuente de iluminación que tiene esta luminaria sólo puede remplazarse por el fabricante o por un instalador autorizado.

La sorgente luminosa incorporata in questo apparecchio può essere sostituita solo dal produttore, da un suo centro assistenza oppure da una persona in possesso della necessaria abilitazione.