

iMAX® Adjustable Trimless BR8

DEEL
PARTIE
TEIL
PART
PARTE
PARTE **A**

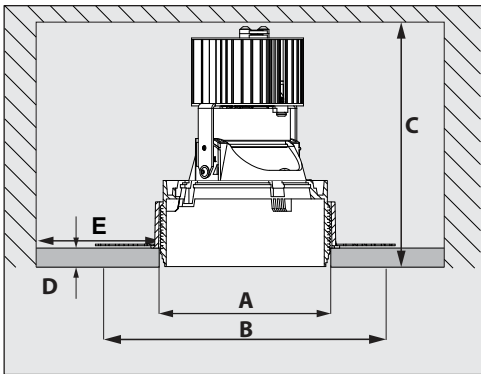
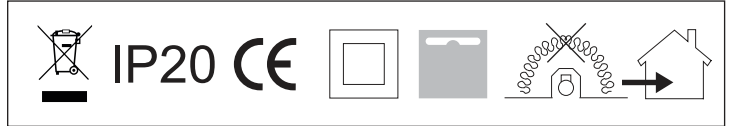
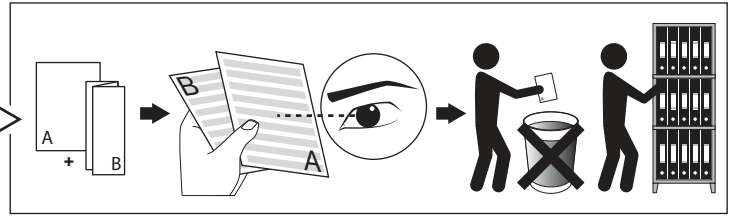
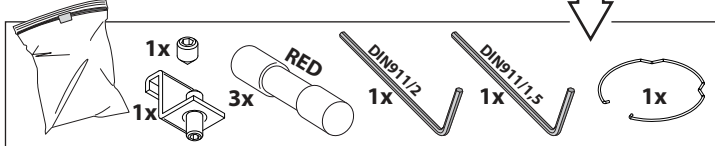
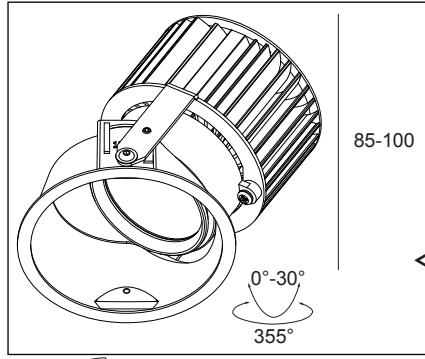

	mm
	A øKIT O.F.A
	B 195
	C 160
	D 25
	E ≥50

REQUIREMENTS

iMAX® COVER

Mounting kit R102 Trimless O.F.A.

ACCESSORIES

iMAX accessories

I_o	350mA	OR	500mA
P_o	7,1W		10,4W
U_f Typical	20,2V-DC		20,7V-DC



Beschermd tegen vaste voorwerpen die groter zijn dan 12 mm
Protégé contre les objets solides de plus de 12 mm
Geschützt gegen Festkörper größer als 12 mm
Protected against solid objects greater than 12 mm
Protegido contra objetos sólidos superiores a 12 mm
Protetto contro oggetti solidi più grandi di 12 mm



Goederen zijn dubbel geïsoleerd - geen aarding nodig
Les produits ont une isolation double et ne peuvent pas être mis à la terre
Güter sind doppelt isoliert und müssen nicht geerdet werden
Goods have double insulation and must not be grounded
Los productos tienen u aislamiento doble y no se pueden conectar a tierra
I prodotti possiedono un doppio isolamento e non devono essere collegati a terra

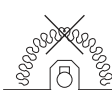

Toestel niet geschikt om te worden afgedekt met thermische isolatie.
Luminaire non appropriées pour recouvrement d'un matériau isolant thermique.
Das Gerät/Die Leuchte darf nicht abgedeckt werden mit thermischer Isolation.
Luminaire not suitable for covering with insulating material.
Luminaria no apta para cubrir con material aislante.
Apparecchio non adatto per essere coperto da materiale isolante.

1

MOUNTING KIT R102 TRIMLESS O.F.A.
400 91 02 OFA

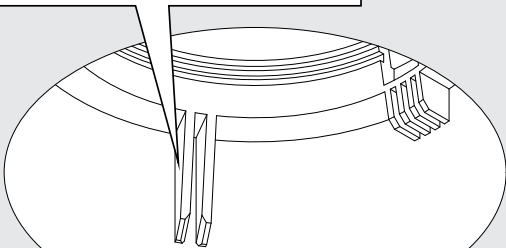

2

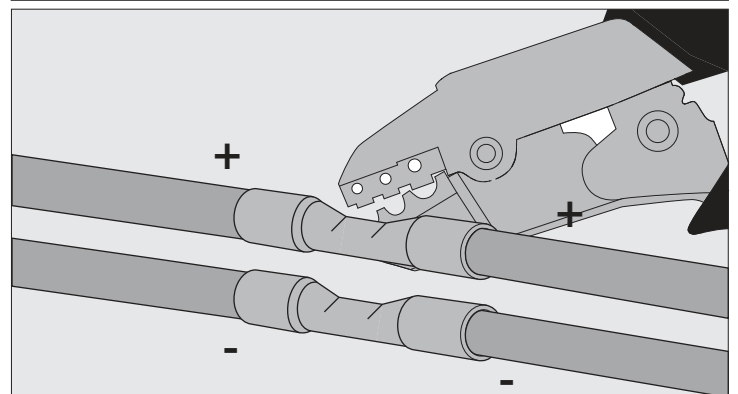
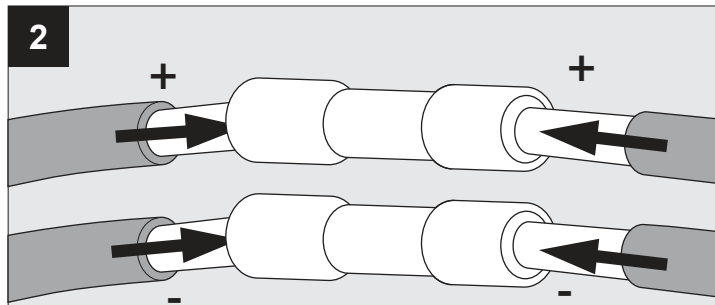

ELECTRICAL CONNECTION

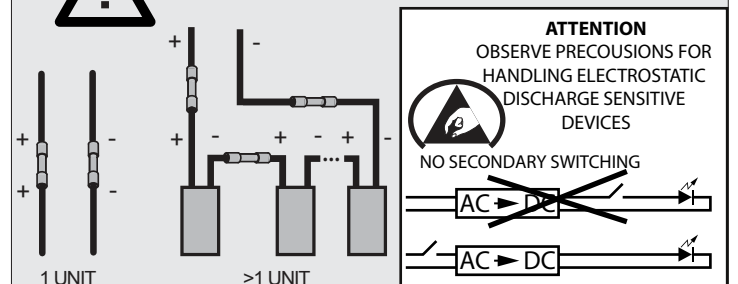

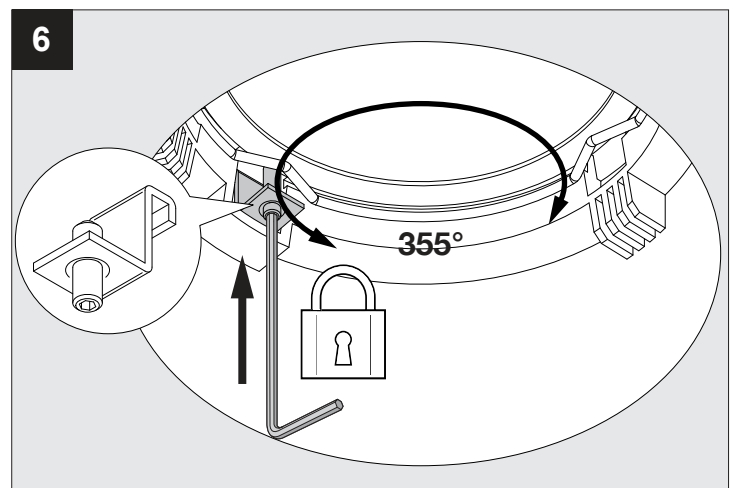
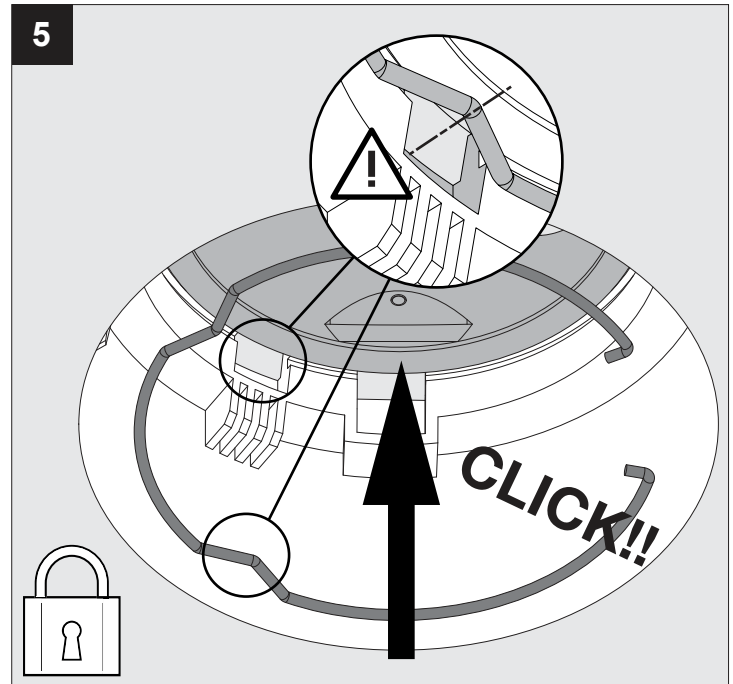
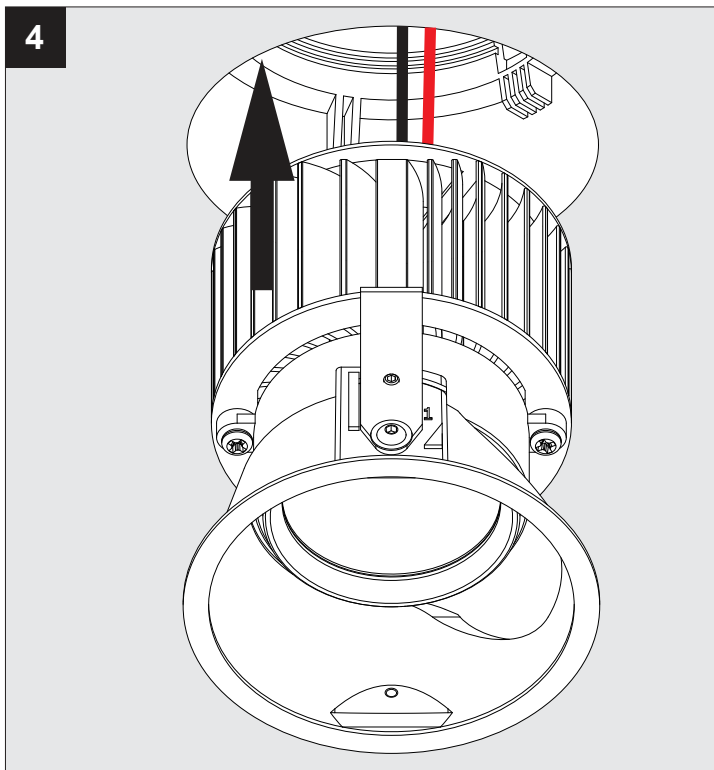
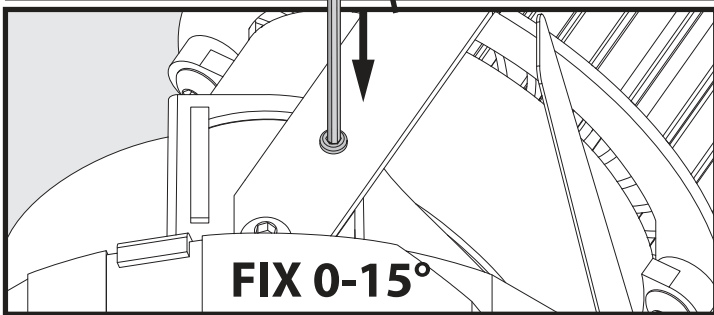
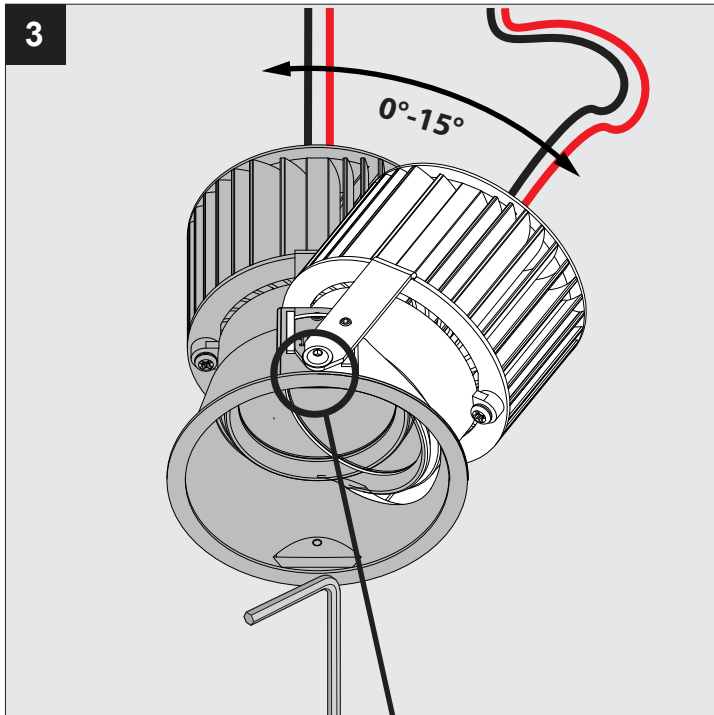

7 INSTALLING COVER

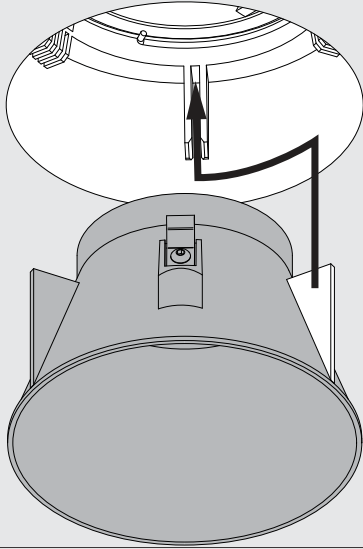

De verlichtingsbron van dit verlichtingstoestel zal enkel door de fabrikant of door de fabrikant aangestelde installateur vervangen worden.

La source lumière de cet appareil ne sera remplacée que par l'entreprise ou par un agent reconnu.

Das enthaltene Leuchtmittel sollte nur durch entsprechendes Fachpersonal ersetzt werden.

The light source contained in this luminaire shall only be replaced by the manufacturer or his service agent.

La fuente de iluminación que tiene esta luminaria sólo puede remplazarse por el fabricante o por un instalador autorizado.

La sorgente luminosa incorporata in questo apparecchio può essere sostituita solo dal produttore, da un suo centro assistenza oppure da una persona in possesso della necessaria abilitazione.