

**DIRO OK S1** ◊  
**202 14 11** ◊  
◊ = ALU-ALU / B-MMAT / C-B / W-B / W-W  
ADJUSTABLE 0° - 20°  
GX5.3 / 12V (SELV) / EXCL. TRANSFO  
COOL BEAM 1 x QR-C51 20-35-50W

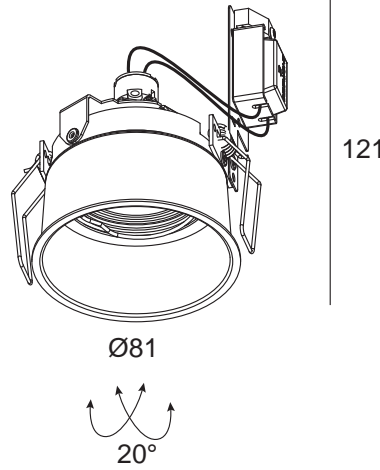

**DIRO ST OK S1** ◊  
**202 14 61** ◊  
◊ = ALU / C / MMAT / W / B  
ADJUSTABLE 0° - 20°  
GX5.3 / 12V (SELV) / EXCL. TRANSFO  
COOL BEAM 1 x QR-C51 20-35-50W

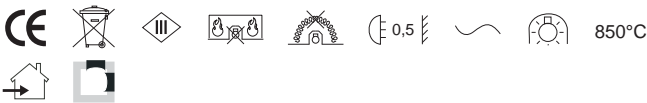

ACCESSORIES / OPTIONS:

**PLASTERKIT 101**  
**202 11 19**  
**DICROIC FILTER 50**  
**202 30 11** (BLUE)  
**202 30 12** (GREEN)  
**202 30 13** (RED)  
**202 30 14** (YELLOW)

FOR DIRO ST ONLY:

**DIRO ST - PLATE** ◊  
**202 14 00** ◊  
◊ = ALU / W

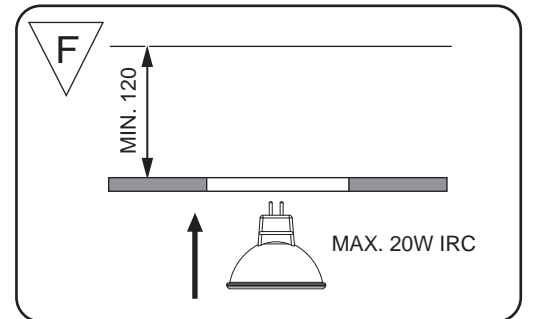

**WAARSCHUWING** Lees de algemene gebruiksvoorwaarden : **DEEL B**  
**AVERTISSEMENT** Lire attentivement les conditions générales d'utilisation : **PARTIE B**  
**WARNUNG** Lesen Sie die allgemeinen Gebrauchsanweisungen : **TEIL B**  
**WARNING** Read the general directions : **PART B**  
**AMMONIZIONE** Leggere attentamente le condizioni generali di utilizzazione : **PARTE B**  
**EDVERTENCIA** Leer atentamente las condiciones generales de uso : **PARTE B**



Waarschuwing tegen het gebruik van koudstraal lampen  
Mise en garde contre l'utilisation de lampes à faisceau froid  
Warnung vor der Verwendung von Kaltstrahlampen  
Warning against the use of cool-beam lamps  
Alarma contra el uso de lámparas de haz frío  
Divieto dell'uso di lampade a luce fredda



Correcte verwijdering van dit product (Elektrische & elektronische afvalapparatuur)  
Comment éliminer ce produit (Déchets d'équipements électriques et électroniques)  
Korrekte Entsorgung dieses Produkts (Elektromüll)  
Correct disposal of this product (Waste electrical & electronic equipment)  
Eliminación correcta de este producto (Material eléctrico y electrónico de descarte)  
Corretto smaltimento del prodotto (Rifiuti elettrici ed elettronici)



Enkel geschikt voor toestellen op zeer lage spanning (minder dan 50 V AC)  
Convient uniquement pour les produits à très basse tension (moins de 50 V AC)  
Geeignet für Güter mit sehr niedriger Spannung (unter 50 V AC)  
Only suited for goods at very low voltage (below 50 V AC)  
Se recomienda únicamente para aquellos productos de tensión muy baja (menos de 50 V AC)  
Vale unicamente per i prodotti a tensione molto bassa (inferiore a 50 V AC)



Verlichtingstoestellen die niet geschikt zijn voor rechtstreekse montage op ontvlambare oppervlakken (alleen geschikt voor montage op onontvlambare oppervlakken)  
Luminaires inappropriés à un montage direct sur des surfaces normalement inflammables (appropriés uniquement à un montage sur des surfaces ininflammables)  
Nicht für direkte Montage auf normal entflammbaren Flächen geeignete Lampen (nur geeignet für montage auf nicht entflammbaren Flächen)  
Luminaires not suitable for direct mounting on normally flammable surfaces (suitable only for mounting on non-flammable surfaces)  
Luminarias no aptas para montaje directo sobre superficies normalmente inflamables (aptas sólo para montaje sobre superficies no inflamables)  
Apparecchi di illuminazione non adatti a essere montati direttamente su superfici normalmente infiammabili (adatti solo a essere montati su superfici non infiammabili)



Toestel niet geschikt om te worden afgedekt met thermische isolatie.  
Luminaire not suitable for covering with insulating material.  
Luminaires non appropriées pour recouvrement d'un matériau isolant thermique.  
Das Gerät/Die Leuchte darf nicht abgedeckt werden mit thermischer Isolation.  
Luminaria no apta para cubrir con material aislante.  
Apparecchio non adatto per essere coperto da materiale isolante.



Verlichtingstoestellen die ontworpen zijn om alleen gebruikt te worden met zelfbeschermende halogeen wolframlampen  
Luminaires conçus pour être utilisés uniquement avec des lampes tungstène halogène autoprotégées  
Lampen, die nur zur Verwendung mit Tungsten-Halogenlampen konzipiert und  
Luminaires designed for use with self-shielded tungsten halogen lamps only  
Luminarias diseñadas para ser utilizadas únicamente con lámparas de tungsteno halógeno autoprotégidas  
Apparecchi di illuminazione per l'uso unicamente con lampade al tungsteno alogene

850°C Gloeitest  
Fil incandescent  
Glowtest  
Glühtest  
Ensayo de recocido  
Filo incandescente



Installeer het armatuur enkel in ruimten waar direct contact met water onmogelijk is.  
Cet équipement doit être installé dans des pièces hors de toute projection d'eau.  
Diese Leuchte darf nur in Räumen verwendet werden, in denen ein direkter kontakt mit wasser nicht möglich ist  
This fitting should only be installed in rooms where direct contact with water is impossible  
Este aparato solamente puede ser instalado en habitaciones donde el contacto directo con el agua sea imposible  
Questo apparecchio di illuminazione deve essere installato solamente in locali in cui il contatto con l'acqua è impossibile.



Bevestiging wand + plafond inbouw  
Montage mur + plafond encastré  
Montage wand + decke eingebaut  
Fixation wall + ceiling recessed  
Montaje pared + techo empotrado  
Montaggio parete + soffitto incasso



Minimum afstand van de verlichte voorwerpen (meter)  
Distance minimale par rapport aux objets éclairés (mètres)  
Mindestabstand von beleuchteten Gegenständen (Meter)  
Minimum distance from lighted objects (metres)  
Distancia mínima de los objetos iluminados (metros)  
Distanza min. dagli oggetti illuminati (metri)



Wisselstroomtoevoer  
Alimentation AC  
WS-Zufuhr  
AC supply  
Alimentación de CA  
Alimentazione CA

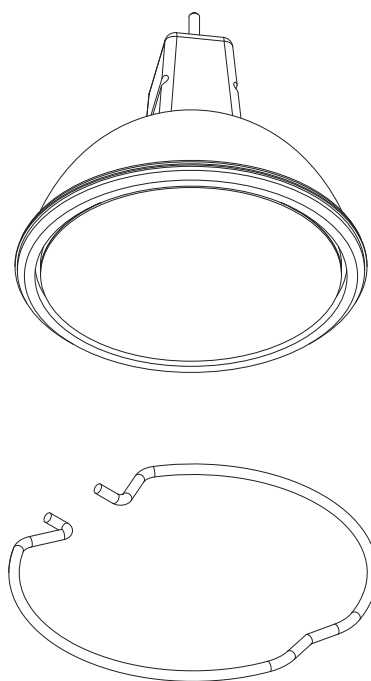
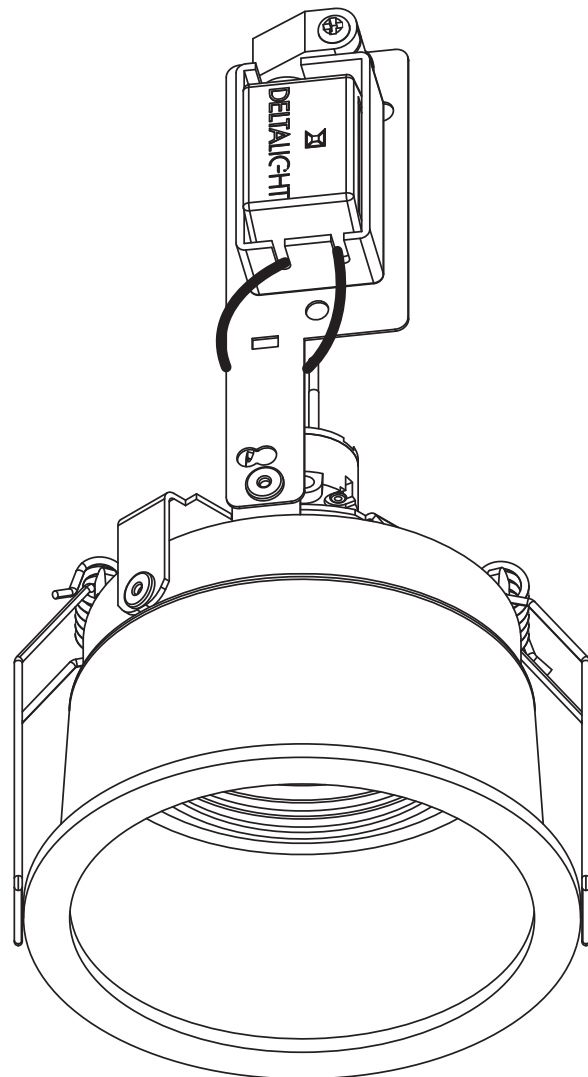
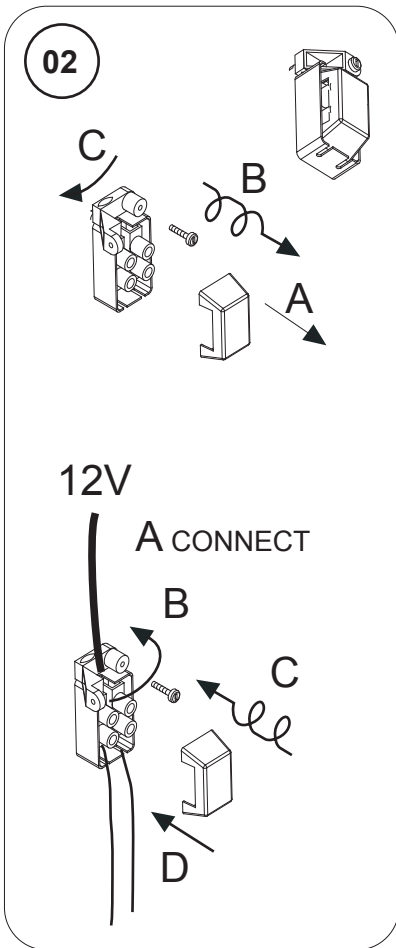
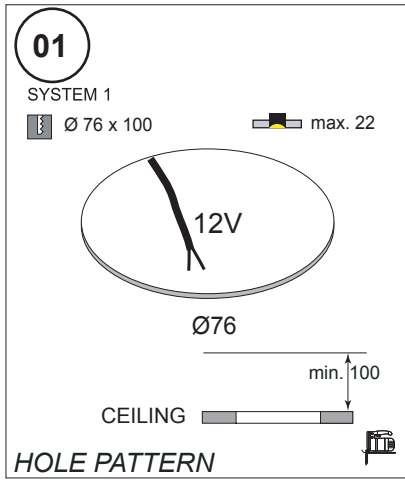

**04**



01. MAKE HOLE PATTERN
02. MAKE THE ELECTRICAL CONNECTION
03. PLACE THE DEVICE
04. INSERT/REPLACE LAMP
05. SWITCH ON

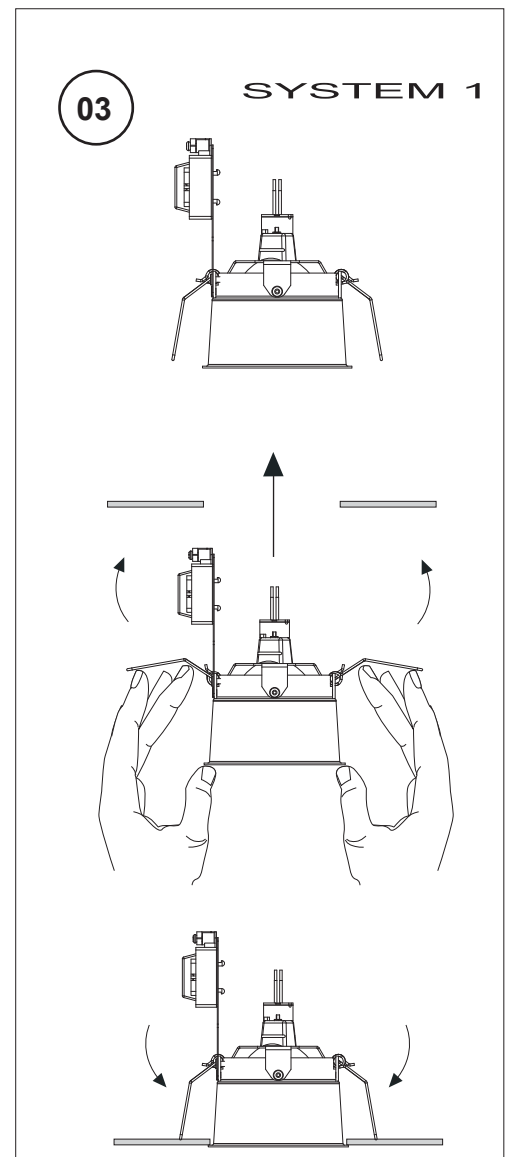
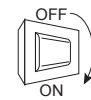

DIRO ST - PLATE  
FOR DIRO ST ONLY

