



ONA

'Ethereal Orb'

Designed by
Peter Straka
Vienna 2014 - 15

Strong and sculptural, the ONA chandelier is formed of three circular bands of warm, bright light that join together to form a perfect sphere. Measuring over a metre in diameter, ONA is impressive in its scale but lightweight in its appearance thanks to its minimal, precise lines, simple geometry and smart use of LED technology.

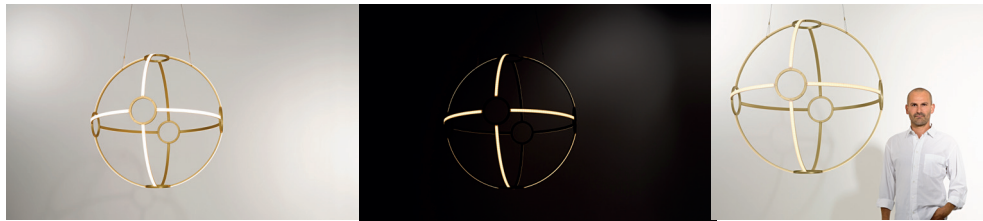

Process: The base material of the ONA is brass. The brass is cut, bent in its shape, then polished and lacquered in matt to maintain its natural colour. The orb is assembled with LED technology and finished with flexible glass components.

ONA 100

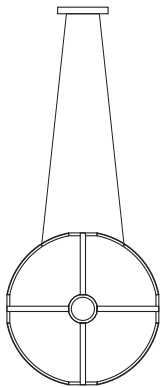

Type	Suspension light
Material	Solid brass
Environment	Indoors
Dimensions	Ø 1070 mm
Cable Length	2000 mm
Weight	9 kg
Certification	IP20 CE
Lamping	LED technology, 24 V*, Warm White 2500 K, 15620 lm, Energy Class A
LED Watt	216 W
020 01 202 11	Brushed brass with transparent cable

O N A 70

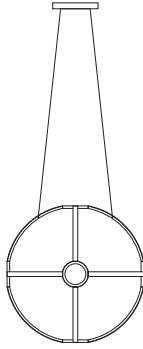

Type	Suspension light
Material	Solid brass
Environment	Indoors
Dimensions	Ø 750 mm
Cable Length	2000 mm
Weight	7 kg
Certification	IP20 CE
Lamping	LED technology, 24 V*, Warm White 2500 K, 1100 lm, Energy Class A
LED Watt	150 W
020 02 202 11	Brushed brass with transparent cable

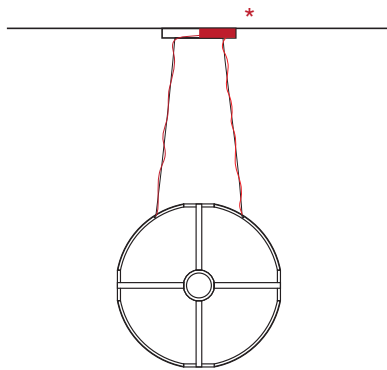
O N A
Mounting Options

Ceiling Rose
square 290 x 290 x 50 mm

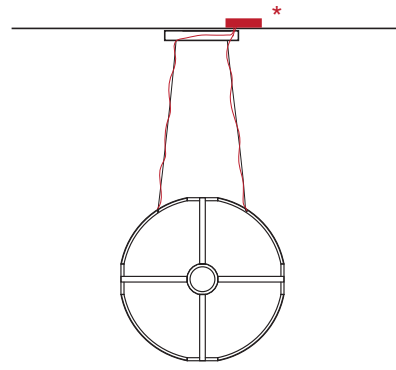

Ceiling Rose
square 290 x 290 x 50 mm

*Power supply location

Dimming Options

Dimming options are available on request (DMX, 1-10 V, Dali, PushDim, RemoteControl). Lighting control system specifications should be clarified before placing the order .

* Please contact sales@kaia.at for further information on dimmers, transformers etc. Please note KAIA Ltd cannot take any responsibility for the connection with your dimming or central control system. It is the customer's responsibility to ensure the compatibility with their systems.

www.kaia.at

sales@kaia.at